

OV5647 5-megapixel product brief



5-megapixel 1/4" Image Sensor with 1.4 μm OmniBSI Technology Offering HD Video



available in a lead-free package

The OV5647 is a 5-megapixel CMOS image sensor built on OmniVision's proprietary 1.4-micron OmniBSI™ backside illumination pixel architecture. The OV5647 delivers 5-megapixel photography in addition to high frame rate of 720p/60 and 1080p/30 high-definition (HD) video capture in an industry standard camera module size of 8.5 x 8.5 x 5 mm, making it an ideal solution for the mainstream mobile phone market.

The 720p/60 HD video is captured in full field of view (FOV) with 2x2 binning to double the sensitivity and improve signal-to-noise ratio (SNR). The post binning re-sampling filter helps minimize spatial and aliasing artifacts to provide superior image quality.

OmniBSI technology offers significant performance benefits over front-side illumination technology, such as increased sensitivity per unit area, improved quantum efficiency,

reduced crosstalk and photo response non-uniformity, which all contribute to significant improvements in image quality and color reproduction. Additionally, OmniVision CMOS image sensors use proprietary sensor technology to improve image quality by reducing or eliminating common lighting/electrical sources of image contamination, such as fixed pattern noise and smearing to produce a clean, fully stable color image.

The low power OV5647 supports a digital video parallel port or high-speed two-lane MIPI interface, and provides full-frame, windowed or binned 10-bit images in RAW RGB format. It offers all required automatic image control functions, including automatic exposure control, automatic white balance, automatic band filter, automatic 50/60 Hz luminance detection, and automatic black level calibration.

Find out more at www.ovt.com.

Applications

- Mobile Phones
- Digital Still Cameras
- PC Multimedia

Product Features

- 1.4 μm x 1.4 μm pixel with OmniBSI technology for high performance (high sensitivity, low crosstalk, low noise)
- optical size of 1/4"
- automatic image control functions:
 - automatic exposure control (AEC)
 - automatic white balance (AWB)
 - automatic band filter (ABF)
 - automatic 50/60 Hz luminance detection
 - automatic black level calibration (ABLCL)
- programmable controls for frame rate, AEC/AGC 16-zone size/position/weight control, mirror and flip, cropping, windowing, and panning
- image quality controls: lens correction, defective pixel canceling
- support for output formats: 8-/10-bit raw RGB data
- support for video or snapshot operations
- support for LED and flash strobe mode
- support for internal and external frame synchronization for frame exposure mode
- support for 2x2 binning for better SNR in low light conditions
- post binning resampling filter to minimize spatial/aliasing artifacts on 2x2 binned image
- support for horizontal and vertical sub-sampling
- standard serial SCCB interface
- digital video port (DVP) parallel output interface
- MIPI interface (two lanes)
- 32 bytes of embedded one-time programmable (OTP) memory
- on-chip phase lock loop (PLL)
- embedded 1.5V regulator for core power
- programmable I/O drive capability, I/O tri-state configurability
- support for black sun cancellation

OV5647

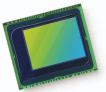

Ordering Information

- OV05647-G04A (color, chip probing, 200 μm backgrinding, reconstructed wafer)

Product Specifications

- active array size: 2592 x 1944
- max S/N ratio: 34 dB
- power supply:
 - core: 1.5V \pm 5% (with embedded 1.5V regulator)
 - analog: 2.6 - 3.0V (2.8V typical)
 - I/O: 1.7 - 3.0V
- power requirements:
 - active: 96 mA
 - standby: 20 μA
- temperature range:
 - operating: -30°C to 70°C junction temperature
 - stable image: 0°C to 50°C junction temperature
- output formats: 8-/10-bit RGB RAW data
- lens size: 1/4"
- lens chief ray angle: 24°
- input clock frequency: 6 - 27 MHz
- dynamic range: 67 dB @ 8x gain
- maximum image transfer rate:
 - QSXGA (2592x1944): 15 fps
 - 1080p: 30 fps
 - 960p: 45 fps
 - 720p: 60 fps
 - VGA (640x480): 90 fps
- sensitivity: 600 mV/lux-sec
- shutter: rolling shutter
- maximum exposure interval: 1968 x t_{row}
- pixel size: 1.4 μm x 1.4 μm
- dark current: 8 mV/sec @ 50°C junction temperature
- image area: 3673.6 μm x 2738.4 μm
- die dimensions: 5520 μm x 4700 μm

Functional Block Diagram

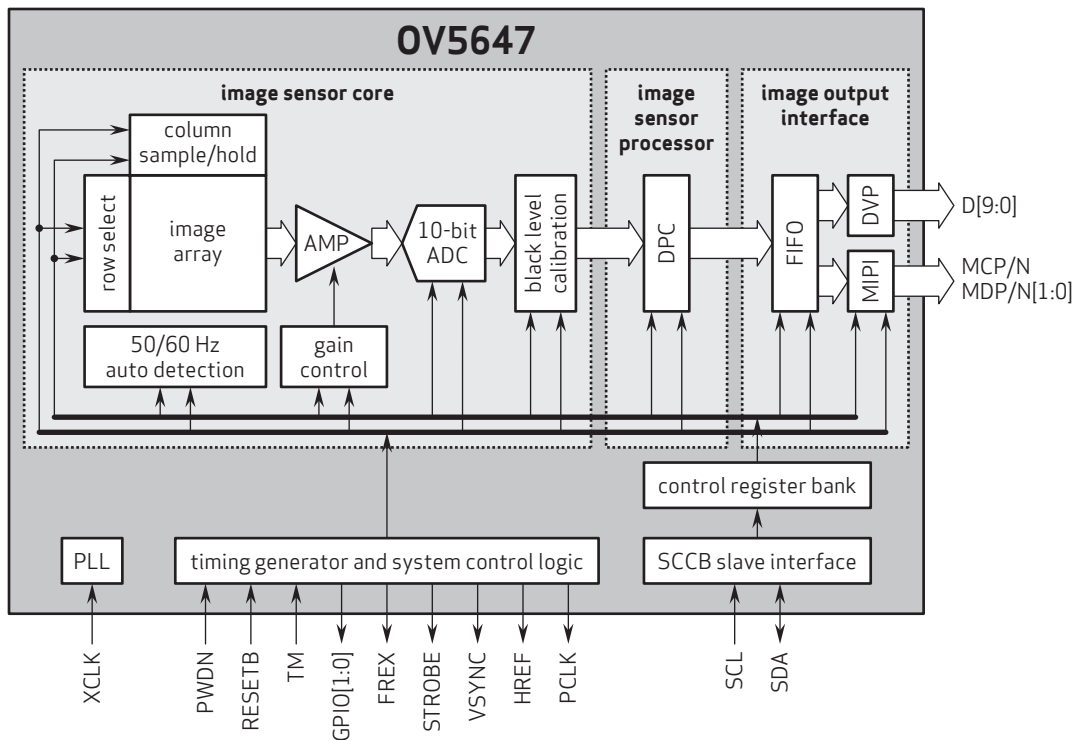

4275 Burton Drive
Santa Clara, CA 95054
USA

Tel: + 1 408 567 3000
Fax: + 1 408 567 3001
www.ovt.com

OmniVision reserves the right to make changes to their products or to discontinue any product or service without further notice. OmniVision, the OmniVision logo and OmniPixel are registered trademarks of OmniVision Technologies, Inc. OmniBSI is a trademark of OmniVision Technologies, Inc. All other trademarks are the property of their respective owners.

