

MC56F8006/MC56F8002



48-pin LQFP
Case: 932-03
7 x 7 mm²



32-pin LQFP
Case: 873A-03
7 x 7 mm²

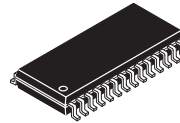

28-pin SOIC
Case: 751F-05
7.5 x 18 mm²

MC56F8006/MC56F8002 Digital Signal Controller

The 56F8006/56F8002 is a member of the 56800E core-based family of digital signal controllers (DSCs). It combines, on a single chip, the processing power of a DSP and the functionality of a microcontroller with a flexible set of peripherals to create an extremely cost-effective solution. Because of its low cost, configuration flexibility, and compact program code, the 56F8006/56F8002 is well-suited for many applications. The 56F8006/56F8002 includes many peripherals that are especially useful for cost-sensitive applications, including:

- Industrial control
- Home appliances
- Smart sensors
- Fire and security systems
- Switched-mode power supply and power management
- Power metering
- Motor control (ACIM, BLDC, PMSM, SR, and stepper)
- Handheld power tools
- Arc detection
- Medical device/equipment
- Instrumentation
- Lighting ballast

The 56800E core is based on a dual Harvard-style architecture consisting of three execution units operating in parallel, allowing as many as six operations per instruction cycle. The MCU-style programming model and optimized instruction set allow straightforward generation of efficient, compact DSP and control code. The instruction set is also highly efficient for C compilers to enable rapid development of optimized control applications.

The 56F8006/56F8002 supports program execution from internal memories. Two data operands can be accessed from the on-chip data RAM per instruction cycle. The 56F8006/56F8002 also offers up to 40 general-purpose input/output (GPIO) lines, depending on peripheral configuration.

The 56F8006/56F8002 digital signal controller includes up to 16 KB of program flash and 2 KB of unified data/program RAM. Program flash memory can be independently bulk erased or erased in small pages of 512 bytes (256 words).

On-chip features include:

- Up to 32 MIPS at 32 MHz core frequency
- DSP and MCU functionality in a unified, C-efficient architecture
- On-chip memory
 - 56F8006: 16 KB (8K x 16) flash memory
 - 56F8002: 12 KB (6K x 16) flash memory
 - 2 KB (1K x 16) unified data/program RAM
- One 6-channel PWM module
- Two 28-channel, 12-bit analog-to-digital converters (ADCs)
- Two programmable gain amplifiers (PGA) with gain up to 32x
- Three analog comparators
- One programmable interval timer (PIT)
- One high-speed serial communication interface (SCI) with LIN slave functionality
- One serial peripheral interface (SPI)
- One 16-bit dual timer (2 x 16 bit timers)
- One programmable delay block (PDB)
- One SMBus compatible inter-integrated circuit (I²C) port
- One real time counter (RTC)
- Computer operating properly (COP)/watchdog
- Two on-chip relaxation oscillators — 1 kHz and 8 MHz (400 kHz at standby mode)
- Crystal oscillator
- Integrated power-on reset (POR) and low-voltage interrupt (LVI) module
- JTAG/enhanced on-chip emulation (OnCE™) for unobtrusive, real-time debugging
- Up to 40 GPIO lines
- 28-pin SOIC, 32-pin LQFP, and 48-pin LQFP packages

This document contains information on a product under development. Freescale reserves the right to change or discontinue this product without notice.

© Freescale Semiconductor, Inc., 2009. All rights reserved.

Table of Contents

1	MC56F8006/MC56F8002 Family Configuration	3	8	Specifications	40
2	Block Diagram	4	8.1	General Characteristics	40
3	Overview	4	8.2	Absolute Maximum Ratings	41
3.1	56F8006/56F8002 Features	4	8.3	Thermal Characteristics	42
3.2	Award-Winning Development Environment	8	8.4	Recommended Operating Conditions	44
3.3	Architecture Block Diagram	9	8.5	DC Electrical Characteristics	45
3.4	Product Documentation	11	8.6	Supply Current Characteristics	49
4	Signal/Connection Descriptions	11	8.7	Flash Memory Characteristics	50
4.1	Introduction	11	8.8	External Clock Operation Timing	51
4.2	Pin Assignment	13	8.9	Phase Locked Loop Timing	51
4.3	56F8006/56F8002 Signal Pins	16	8.10	Relaxation Oscillator Timing	52
5	Memory Maps	28	8.11	Reset, Stop, Wait, Mode Select, and Interrupt Timing	53
5.1	Introduction	28	8.12	External Oscillator (XOSC) Characteristics	53
5.2	Program Map	28	8.13	AC Electrical Characteristics	54
5.3	Data Map	29	8.14	COP Specifications	62
5.4	Interrupt Vector Table and Reset Vector	30	8.15	PGA Specifications	62
5.5	Peripheral Memory-Mapped Registers	31	8.16	ADC Specifications	63
5.6	EOnCE Memory Map	32	8.17	HSCMP Specifications	65
6	General System Control Information	33	8.18	Optimize Power Consumption	65
6.1	Overview	33	9	Design Considerations	67
6.2	Power Pins	33	9.1	Thermal Design Considerations	67
6.3	Reset	33	9.2	Electrical Design Considerations	68
6.4	On-chip Clock Synthesis	33	9.3	Ordering Information	69
6.5	Interrupt Controller	36	10	Package Mechanical Outline Drawings	70
6.6	System Integration Module (SIM)	36	10.1	28-pin SOIC Package	70
6.7	PWM, PDB, PGA, and ADC Connections	37	10.2	32-pin LQFP	73
6.8	Joint Test Action Group (JTAG)/Enhanced On-Chip Emulator (EOnCE)	38	10.3	48-pin LQFP	76
7	Security Features	38	Appendix A		
7.1	Operation with Security Enabled	39	Interrupt Vector Table	78	
7.2	Flash Access Lock and Unlock Mechanisms	39	Appendix B		
7.3	Product Analysis	40	Peripheral Register Memory Map and Reset Value	80	

1 MC56F8006/MC56F8002 Family Configuration

MC56F8006/MC56F8002 device comparison in [Table 1](#).

Table 1. MC56F8006 Series Device Comparison

Feature	MC56F8006			MC56F8002
	28-pin	32-pin	48-pin	28-pin
Flash memory size (Kbytes)	16			12
RAM size (Kbytes)	2			
Analog comparators (ACMP)	3			
Analog-to-digital converters (ADC)	2			
Unshielded ADC inputs	6	7	7	6
Shielded ADC inputs	9	11	17	9
Total number of ADC input pins ¹	15	18	24	15
Programmable gain amplifiers (PGA)	2			
Pulse-width modulator (PWM) outputs	6			
PWM fault inputs	3	4	4	3
Inter-integrated circuit (IIC)	1			
Serial peripheral interface (SPI)	1			
High speed serial communications interface (SCI)	1			
Programmable interrupt timer (PIT)	1			
Programmable delay block (PDB)	1			
16-bit multi-purpose timers (TMR)	2			
Real-time counter (RTC)	1			
Computer operating properly (COP) timer	Yes			
Phase-locked loop (PLL)	Yes			
1 kHz on-chip oscillator	Yes			
8 MHz (400 kHz at standby mode) on-chip ROSC	Yes			
Crystal oscillator	Yes			
Power management controller (PMC)	Yes			
IEEE 1149.1 Joint Test Action Group (JTAG) interface	Yes			
Enhanced on-chip emulator (EOnCE) IEEE 1149.1 Joint Test Action Group (JTAG) interface	Yes			

¹ Some ADC inputs share the same pin. See [Table 4](#).

2 Block Diagram

Figure 1 shows a top-level block diagram of the MC56F8006/MC56F8002 digital signal controller. Package options for this family are described later in this document. Italics indicate a 56F8002 device parameter.

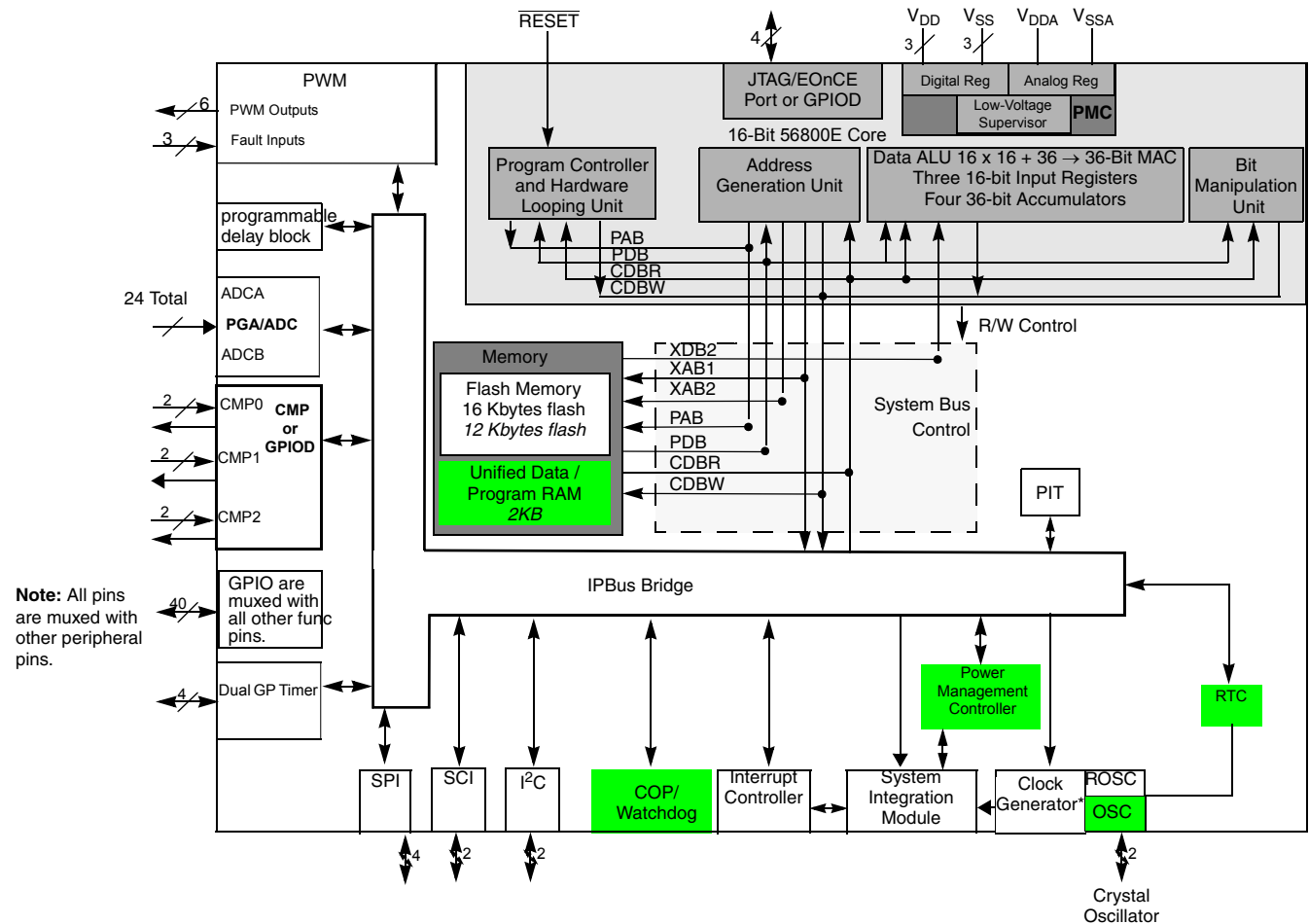

Figure 1. MC56F8006/MC56F8002 Block Diagram

3 Overview

3.1 56F8006/56F8002 Features

3.1.1 Core

- Efficient 16-bit 56800E family digital signal controller (DSC) engine with dual Harvard architecture
- As many as 32 million instructions per second (MIPS) at 32 MHz core frequency
- 155 basic instructions in conjunction with up to 20 address modes
- Single-cycle 16 × 16-bit parallel multiplier-accumulator (MAC)
- Four 36-bit accumulators, including extension bits
- 32-bit arithmetic and logic multi-bit shifter

- Parallel instruction set with unique DSP addressing modes
- Hardware DO and REP loops
- Three internal address buses
- Four internal data buses
- Instruction set supports DSP and controller functions
- Controller-style addressing modes and instructions for compact code
- Efficient C compiler and local variable support
- Software subroutine and interrupt stack with depth limited only by memory
- JTAG/enhanced on-chip emulation (EOnCE) for unobtrusive, processor speed-independent, real-time debugging

3.1.2 Operation Range

- 1.8 V to 3.6 V operation (power supplies and I/O)
- From power-on-reset: approximately 1.9 V to 3.6 V
- Ambient temperature operating range: -40 °C to 105 °C

3.1.3 Memory

- Dual Harvard architecture permits as many as three simultaneous accesses to program and data memory
- Flash security and protection that prevent unauthorized users from gaining access to the internal flash
- On-chip memory
 - 16 KB of program flash for 56F8006 and 12 KB of program flash for 56F8002
 - 2 KB of unified data/program RAM
- EEPROM emulation capability using flash

3.1.4 Interrupt Controller

- Five interrupt priority levels
 - Three user programmable priority levels for each interrupt source: Level 0, 1, 2
 - Unmaskable level 3 interrupts include: illegal instruction, hardware stack overflow, misaligned data access, SWI3 instruction. Maskable level 3 interrupts include: EOnCE step counter, EOnCE breakpoint unit, EOnCE trace buffer
 - Lowest-priority software interrupt: level LP
- Allow nested interrupt that higher priority level interrupt request can interrupt lower priority interrupt subroutine
- The masking of interrupt priority level is managed by the 56800E core
- One programmable fast interrupt that can be assigned to any interrupt source
- Notification to system integration module (SIM) to restart clock out of wait and stop states
- Ability to relocate interrupt vector table

3.1.5 Peripheral Highlights

- One multi-function, six-output pulse width modulator (PWM) module
 - Up to 96 MHz PWM operating clock
 - 15 bits of resolution
 - Center-aligned and edge-aligned PWM signal mode
 - Phase shifting PWM pulse generation
 - Four programmable fault inputs with programmable digital filter

Overview

- Double-buffered PWM registers
- Separate deadtime insertions for rising and falling edges
- Separate top and bottom pulse-width correction by means of software
- Asymmetric PWM output within both Center Aligned and Edge Aligned operation
- Separate top and bottom polarity control
- Each complementary PWM signal pair allows selection of a PWM supply source from:
 - PWM generator
 - Internal timers
 - Analog comparator outputs
- Two independent 12-bit analog-to-digital converters (ADCs)
 - 2 x 14 channel external inputs plus seven internal inputs
 - Support simultaneous and software triggering conversions
 - ADC conversions can be synchronized by PWM and PDB modules
 - Sampling rate up to 400 KSPS for 10- or 12-bit conversion result; 470 KSPS for 8-bit conversion result
 - Two 16-word result registers
- Two programmable gain amplifier (PGAs)
 - Each PGA is designed to amplify and convert differential signals to a single-ended value fed to one of the ADC inputs
 - 1X, 2X, 4X, 8X, 16X, or 32X gain
 - Software and hardware triggers are available
 - Integrated sample/hold circuit
 - Includes additional calibration features:
 - Offset calibration eliminates any errors in the internal reference used to generate the VDDA/2 output center point
 - Gain calibration can be used to verify the gain of the overall datapath
 - Both features require software correction of the ADC result
- Three analog comparators (CMPs)
 - Selectable input source includes external pins, internal DACs
 - Programmable output polarity
 - Output can drive timer input, PWM fault input, PWM source, external pin output, and trigger ADCs
 - Output falling and rising edge detection able to generate interrupts
- One dual channel 16-bit multi-purpose timer module (TMR)
 - Two independent 16-bit counter/timers with cascading capability
 - Up to 96 MHz operating clock
 - Each timer has capture and compare and quadrature decoder capability
 - Up to 12 operating modes
 - Four external inputs and two external outputs
- One serial communication interface (SCI) with LIN slave functionality
 - Up to 96 MHz operating clock
 - Full-duplex or single-wire operation
 - Programmable 8- or 9- bit data format
 - Two receiver wakeup methods:
 - Idle line
 - Address mark
 - 1/16 bit-time noise detection

- One serial peripheral interface (SPI)
 - Full-duplex operation
 - Master and slave modes
 - Programmable length transactions (2 to 16 bits)
 - Programmable transmit and receive shift order (MSB as first or last bit transmitted)
 - Maximum slave module frequency = module clock frequency/2
- One inter-integrated Circuit (I²C) port
 - Operates up to 400 kbps
 - Supports master and slave operation
 - Supports 10-bit address mode and broadcasting mode
 - Supports SMBus, Version 2
- One 16-bit programmable interval timer (PIT)
 - 16 bit counter with programmable counter modulo
 - Interrupt capability
- One 16-bit programmable delay block (PDB)
 - 16 bit counter with programmable counter modulo and delay time
 - Counter is initiated by positive transition of internal or external trigger pulse
 - Supports two independently controlled delay pulses used to synchronize PGA and ADC conversions with input trigger event
 - Two PDB outputs can be ORed together to schedule two conversions from one input trigger event
 - PDB outputs can be used to schedule precise edge placement for a pulsed output that generates the control signal for the CMP windowing comparison
 - Supports continuous or single shot mode
 - Bypass mode supported
- Computer operating properly (COP)/watchdog timer capable of selecting different clock sources
 - Programmable prescaler and timeout period
 - Programmable wait, stop, and partial powerdown mode operation
 - Causes loss of reference reset 128 cycles after loss of reference clock to the PLL is detected
 - Choice of clock sources from four sources in support of EN60730 and IEC61508:
 - On-chip relaxation oscillator
 - External crystal oscillator/external clock source
 - System clock (IPBus up to 32 MHz)
 - On-chip low power 1 kHz oscillator
- Real-time counter (RTC)
 - 8-bit up-counter
 - Three software selectable clock sources
 - External crystal oscillator/external clock source
 - On-chip low-power 1 kHz oscillator
 - System bus (IPBus up to 32 MHz)
 - Can signal the device to exit power down mode
- Phase lock loop (PLL) provides a high-speed clock to the core and peripherals
 - Provides 3x system clock to PWM and dual timer and SCI
 - Loss of lock interrupt
 - Loss of reference clock interrupt
- Clock sources

Overview

- On-chip relaxation oscillator with two user selectable frequencies: 400 kHz for low speed mode, 8 MHz for normal operation
- On-chip low-power 1 kHz oscillator can be selected as clock source to the RTC and/or COP
- External clock: crystal oscillator, ceramic resonator, and external clock source
- Power management controller (PMC)
 - On-chip regulator for digital and analog circuitry to lower cost and reduce noise
 - Integrated power-on reset (POR)
 - Low-voltage interrupt with a user selectable trip voltage of 1.81 V or 2.31 V
 - User selectable brown-out reset
 - Run, wait, and stop modes
 - Low-power run, wait, and stop modes
 - Partial power down mode
- Up to 40 general-purpose I/O (GPIO) pins
 - Individual control for each pin to be in peripheral or GPIO mode
 - Individual input/output direction control for each pin in GPIO mode
 - Hysteresis and configurable pullup device on all input pins
 - Configurable slew rate and drive strength and optional input low pass filters on all output pins
 - 20 mA sink/source current
- JTAG/EOnCE debug programming interface for real-time debugging
 - IEEE 1149.1 Joint Test Action Group (JTAG) interface
 - EOnCE interface for real-time debugging

3.1.6 Power Saving Features

- Three low power modes
 - Low-speed run, wait, and stop modes: 200 kHz IP bus clock provided by ROsc
 - Low-power run, wait, and stop modes: clock provided by external 32–38.4 kHz crystal
 - Partial power down mode
- Low power external oscillator can be used in any low-power mode to provide accurate clock to active peripherals
- Low power real time counter for use in run, wait, and stop modes with internal and external clock sources
- 32 μ s typical wakeup time from partial power down modes
- Each peripheral can be individually disabled to save power

3.2 Award-Winning Development Environment

Processor Expert™ (PE) provides a Rapid Application Design (RAD) tool that combines easy-to-use component-based software application creation with an expert knowledge system.

The CodeWarrior Integrated Development Environment is a sophisticated tool for code navigation, compiling, and debugging. A complete set of evaluation modules (EVMs), demonstration board kit, and development system cards support concurrent engineering. Together, PE, CodeWarrior, and EVMs create a complete, scalable tools solution for easy, fast, and efficient development.

A full set of programmable peripherals — PWM, PGAs, ADCs, SCI, SPI, I²C, PIT, timers, and analog comparators — supports various applications. Each peripheral can be independently shut down to save power. Any pin in these peripherals can also be used as general-purpose input/outputs (GPIOs).

3.3 Architecture Block Diagram

The 56F8006/56F8002's architecture is shown in Figure 2 and Figure 3. Figure 2 illustrates how the 56800E system buses communicate with internal memories and the IPBus interface and the internal connections among each unit of the 56800E core. Figure 3 shows the peripherals and control blocks connected to the IPBus bridge. Please see the system integration module (SIM) section in the *MC56F8006 Reference Manual* for information about which signals are multiplexed with those of other peripherals.

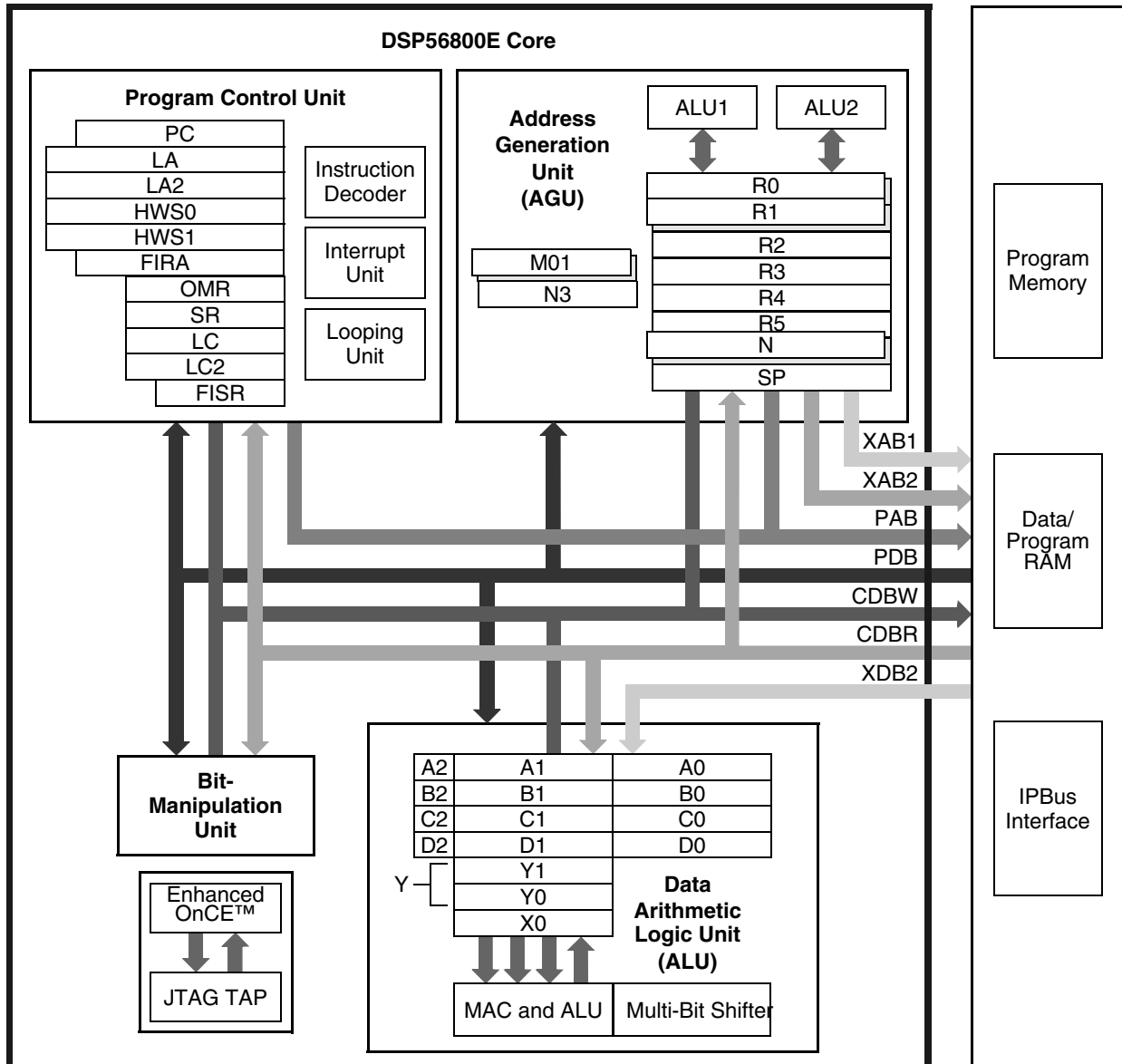

Figure 2. 56800E Core Block Diagram

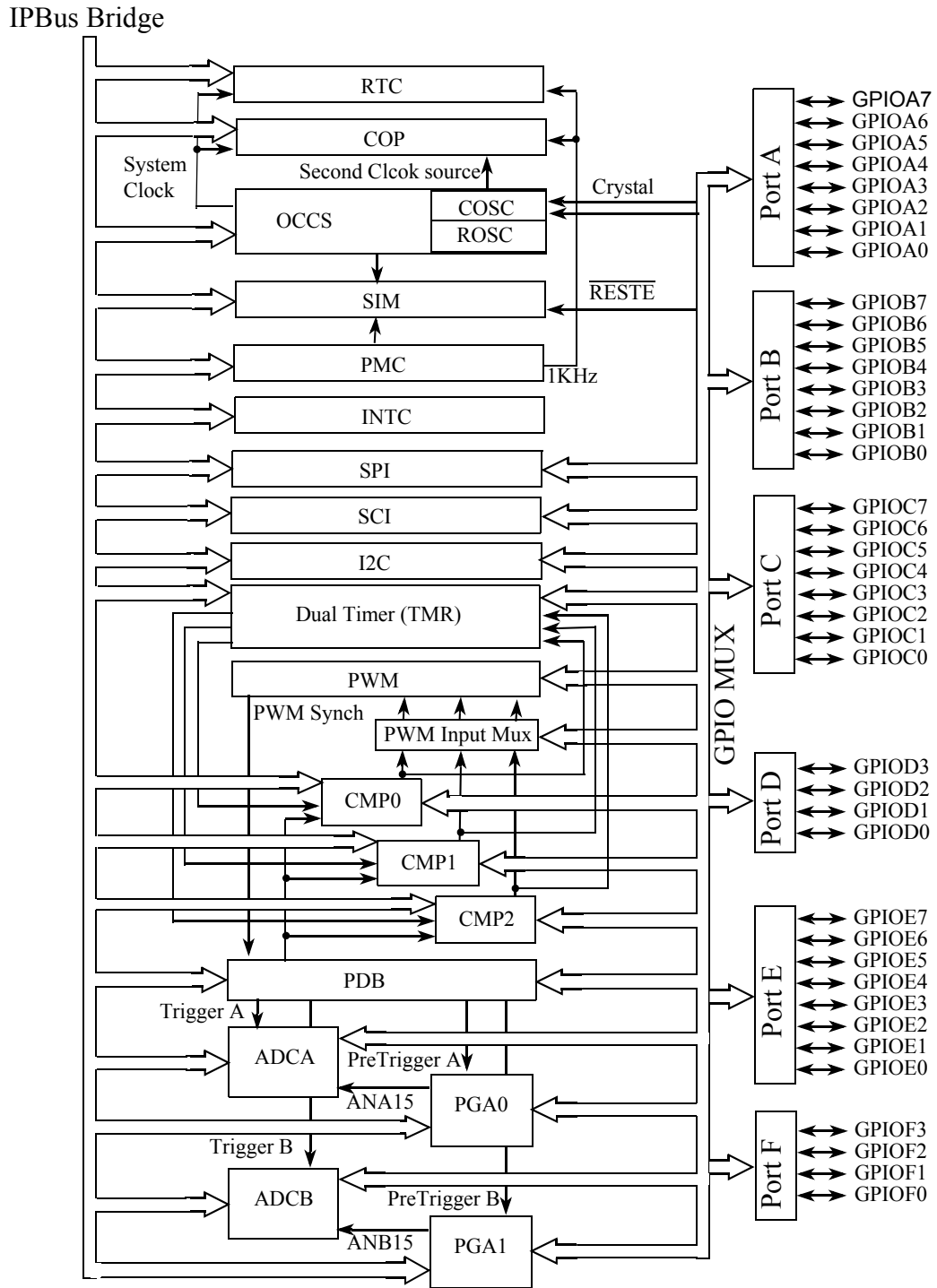

Figure 3. Peripheral Subsystem

3.4 Product Documentation

The documents listed in [Table 2](#) are required for a complete description and proper design with the 56F8006/56F8002. Documentation is available from local Freescale distributors, Freescale Semiconductor sales offices, Freescale Literature Distribution Centers, or online at <http://www.freescale.com>.

Table 2. 56F8006/56F8002 Device Documentation

Topic	Description	Order Number
DSP56800E Reference Manual	Detailed description of the 56800E family architecture, 16-bit digital signal controller core processor, and the instruction set	DSP56800ERM
56F800x Peripheral Reference Manual	Detailed description of peripherals of the 56F8006 and 56F8002 devices	MC56F8006RM
56F80x Serial Bootloader User Guide	Detailed description of the Serial Bootloader in the 56F800x family of devices	TBD
56F8006/56F8002 Technical Data Sheet	Electrical and timing specifications, pin descriptions, and package descriptions (this document)	MC56F8006
56F8006/56F8002 Errata	Details any chip issues that might be present	MC56F8006E

4 Signal/Connection Descriptions

4.1 Introduction

The input and output signals of the 56F8006/56F8002 are organized into functional groups, as detailed in [Table 3](#). [Table 4](#) summarizes all device pins. In [Table 4](#), each table row describes the signal or signals present on a pin, sorted by pin number.

Table 3. Functional Group Pin Allocations

Functional Group	Number of Pins in 28 SOIC	Number of Pins in 32 LQFP	Number of Pins in 48 LQFP
Power Inputs (V_{DD} , V_{DDA})	2	2	4
Ground (V_{SS} , V_{SSA})	3	3	4
Reset ¹	1	1	1
Pulse Width Modulator (PWM) Ports ¹	10	12	12
Serial Peripheral Interface (SPI) Ports ¹	5	7	7
Serial Communications Interface 0 (SCI) Ports ¹	4	5	5
Inter-Integrated Circuit Interface (I ² C) Ports ¹	6	7	7
Analog-to-Digital Converter (ADC) Inputs ¹	16	18	24
High Speed Analog Comparator Inputs ¹	13	15	25
Programmable Gain Amplifiers (PGA) ¹	4	4	4
Dual Timer Module (TMR) Ports ¹	8	10	10
Programmable Delay Block (PDB) ¹	—	—	1
Clock ¹	5	5	5
JTAG/Enhanced On-Chip Emulation (EOnCE ¹)	4	4	4

¹ Pins may be shared with other peripherals. See [Table 4](#).

Signal/Connection Descriptions

In Table 4, peripheral pins in bold identify reset state.

Table 4. 56F8006/56F8002 Pins

Pin Number			Pin Name	Peripherals											
28 SOIC	32 LQFP	48 LQFP		GPIO	I ² C	SCI	SPI	ADC	PGA	COMP	Dual Timer	PWM	Power and Ground	JTAG	Misc.
	1	1	GPIOB6/RXD/SDA/ANA13 and CMP0_P2/CLKIN	B6	SDA	RXD		ANA13 ¹		CMP0_P2					CLKIN
	2	2	GPIOB1/SS/SDA/ANA12 and CMP2_P3	B1	SDA		SS	ANA12 ¹		CMP2_P3					
	3	3	GPIOB7/TXD/SCL/ANA11 and CMP2_M3	B7	SCL	TXD		ANA11 ¹		CMP2_M3					
	4	4	GPIOB5/T1/FAULT3/SCLK	B5			SCLK				T1	FAULT3			
		5	GPIOE0	E0											
		6	GPIOE1/ANB9 and CMP0_P1	E1				ANB9 ¹		CMP0_P1					
28	5	7	ANB8 and PGA1+ and CMP0_M2/GPIOC4	C4				ANB8 ¹	PGA1+	CMP0_M2					
		8	GPIOE2/ANB7 and CMP0_M1	E2				ANB7 ¹		CMP0_M1					
1	6	9	ANB6 and PGA1- and CMP0_P4/GPIOC5	C5				ANB6 ¹	PGA1-	CMP0_P4					
		10	GPIOC7/ANB5 and CMP1_M2	C7				ANB5 ¹		CMP1_M2					
2	7	11	ANB4 and CMP1_P1/GPIOC6/PWM2	C6				ANB4 ¹		CMP1_P1		PWM2			
3	8	12	V _{DDA}									V _{DDA}			
4	9	13	V _{SSA}									V _{SSA}			
		14	GPIOE3/ANA10 and CMP2_M1	E3				ANA10 ¹		CMP2_M1					
5	10	15	ANA9 and PGA0- and CMP2_P4/GPIOC2	C2				ANA9 ¹	PGA0-	CMP2_P4					
		16	GPIOE5/ANA8 and CMP2_P1	E5				ANA8 ¹		CMP2_P1					
6	11	17	ANA7 and PGA0+ and CMP2_M2/GPIOC1	C1				ANA7 ¹	PGA0+	CMP2_M2					
		18	GPIOE4/ANA6 and CMP2_P2	E4				ANA6 ¹		CMP2_P2					
7	12	19	ANA5 and CMP1_M1/GPIOC0/FAULT0	C0				ANA5 ¹		CMP1_M1		FAULT0			
8	13	20	V _{SS}									V _{SS}			
		21	V _{DD}									V _{DD}			
9	14	22	TCK/GPIOD2/ANA4 and CMP1_P2/CMP2_OUT	D2				ANA4 ¹		CMP1_P2, CMP2_OUT				TCK	
10	15	23	RESET/GPIOA7	A7											RESET
11	16	24	GPIOB3/MOSI/TIN3/ANA3 and ANB3/PWM5/CMP1_OUT	B3			MOSI	ANA3 ¹ and ANB3 ¹		CMP1_OUT	TIN3	PWM5			
	17	25	GPIOB2/MISO/TIN2/ANA2 and ANB2/CMP0_OUT	B2			MISO	ANA2 and ANB2		CMP0_OUT	TIN2				
12	18	26	GPIOA6/FAULT0/ANA1 and ANB1/SCL/TXD/CLKO_1	A6	SCL	TXD		ANA1 and ANB1				FAULT0			CLKO_1
13	19	27	GPIOB4/T0/CLKO_0/MISO/SDA/RXD/ANA0 and ANB0	B4	SDA	RXD	MISO	ANA0 and ANB0			T0				CLKO_0

Table 4. 56F8006/56F8002 Pins (continued)

Pin Number			Pin Name	Peripherals											
28 SOIC	32 LQFP	48 LQFP		GPIO	I ² C	SCI	SPI	ADC	PGA	COMP	Dual Timer	PWM	Power and Ground	JTAG	Misc.
		28	GPIOE6	E6											
14	20	29	GPIOA5/PWM5/FAULT2 or EXT_SYNC/TIN3	A5							TIN3	PWM5, FAULT2 or EXT_SYNC			
		30	V _{SS}										V _{SS}		
		31	V _{DD}										V _{DD}		
15	21	32	GPIOB0/SCLK/SCL/ANB13/PWM3/T1	B0	SCL		SCLK	ANB13			T1	PWM3			
16	22	33	GPIOA4/PWM4/SDA/FAULT1/TIN2	A4	SDA						TIN2	PWM4, FAULT1			
		34	GPIOE7/CMP1_M3	E7					CMP1_M3						
	23	35	GPIOA2/PWM2	A2								PWM2			
17	24	36	GPIOA3/PWM3/TXD/EXTAL	A3		TXD						PWM3			EXTAL
18	25	37	GPIOF0/XTAL	F0											XTAL
19	26	38	V _{DD}										V _{DD}		
20	27	39	V _{SS}										V _{SS}		
		40	GPIOF1/CMP1_P3	F1					CMP1_P3						
		41	GPIOF2/CMP0_M3	F2					CMP0_M3						
		42	GPIOF3/CMP0_P3	F3					CMP0_P3						
21	28	43	GPIOA1/PWM1	A1								PWM1			
22	29	44	GPIOA0/PWM0	A0								PWM0			
23	30	45	TDI/GPIOD0/ANB12/SS/TIN2/CMP0_OUT	D0			SS	ANB12	CMP0_OUT	TIN2				TDI	
		46	GPIOC3/EXT_TRIGGER	C3											EXT_TRIGGER
24	31	47	TMS/GPIOD3/ANB11/T1/CMP1_OUT	D3				ANB11	CMP1_OUT	T1				TMS	
25	32	48	TDO/GPIOD1/ANB10/T0/CMP2_OUT	D1				ANB10	CMP2_OUT	T0				TDO	

¹ Shielded ADC input.

4.2 Pin Assignment

MC56F8006 and MC56F8002 28-pin small outline IC (28SOIC) assignment is shown in [Figure 4](#); MC56F8006 32-pin low-profile quad flat pack (32LQFP) is shown in [Figure 5](#); MC56F8006 48-pin low-profile quad flat pack (48LQFP) is shown in [Figure 6](#).

Signal/Connection Descriptions

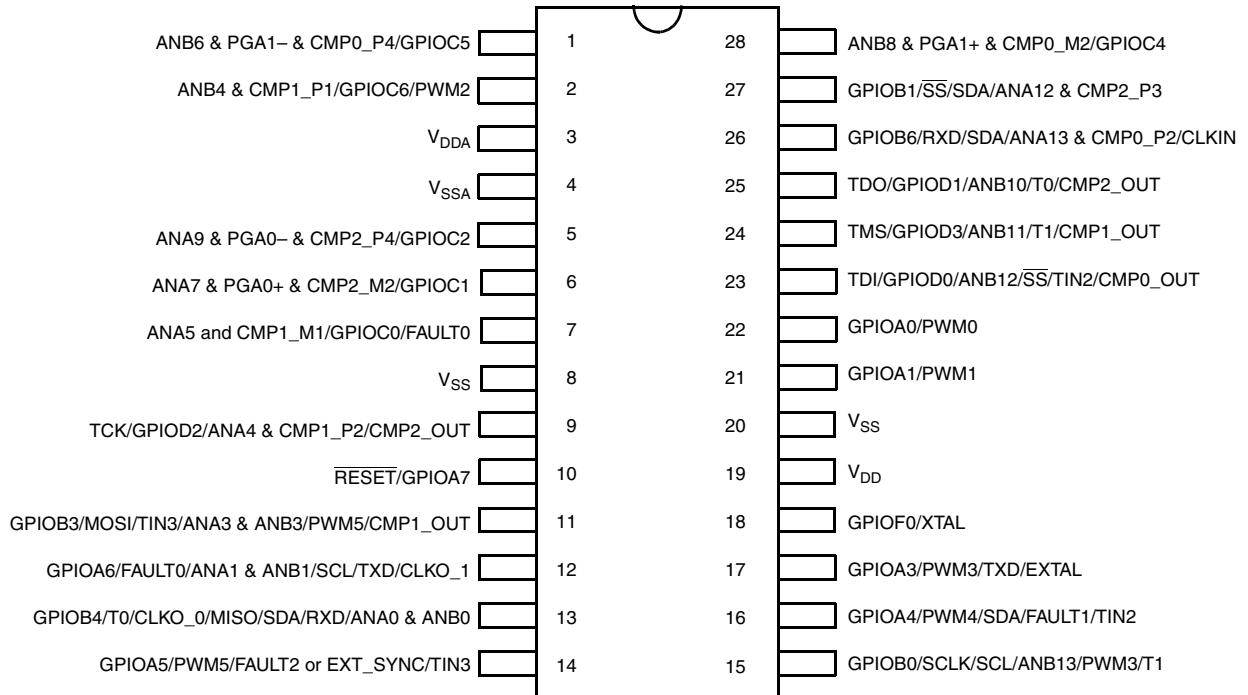

Figure 4. Top View, MC56F8006/MC56F8002 28-Pin SOIC Package

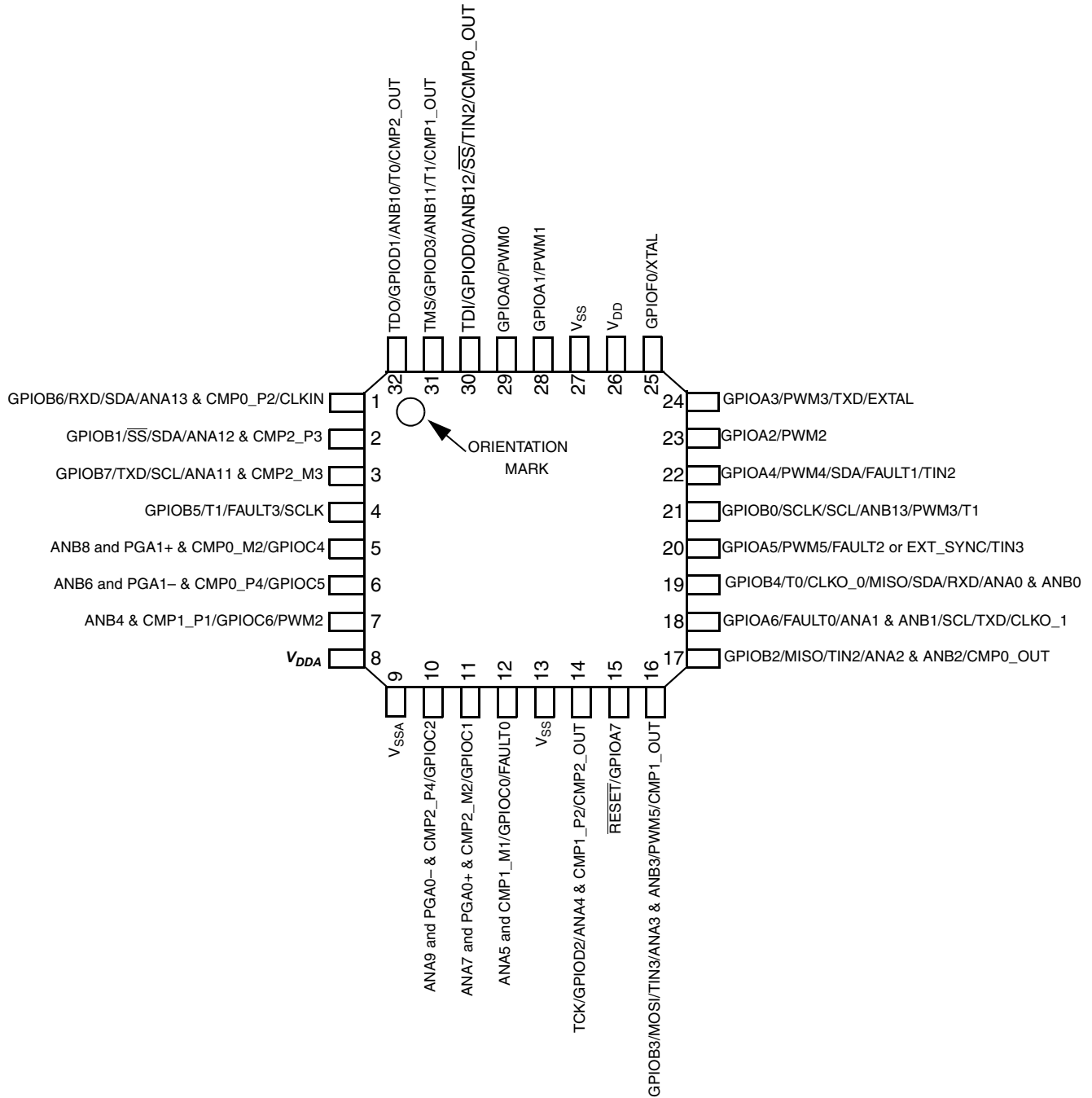

Figure 5. Top View, MC56F8006 32-Pin LQFP Package

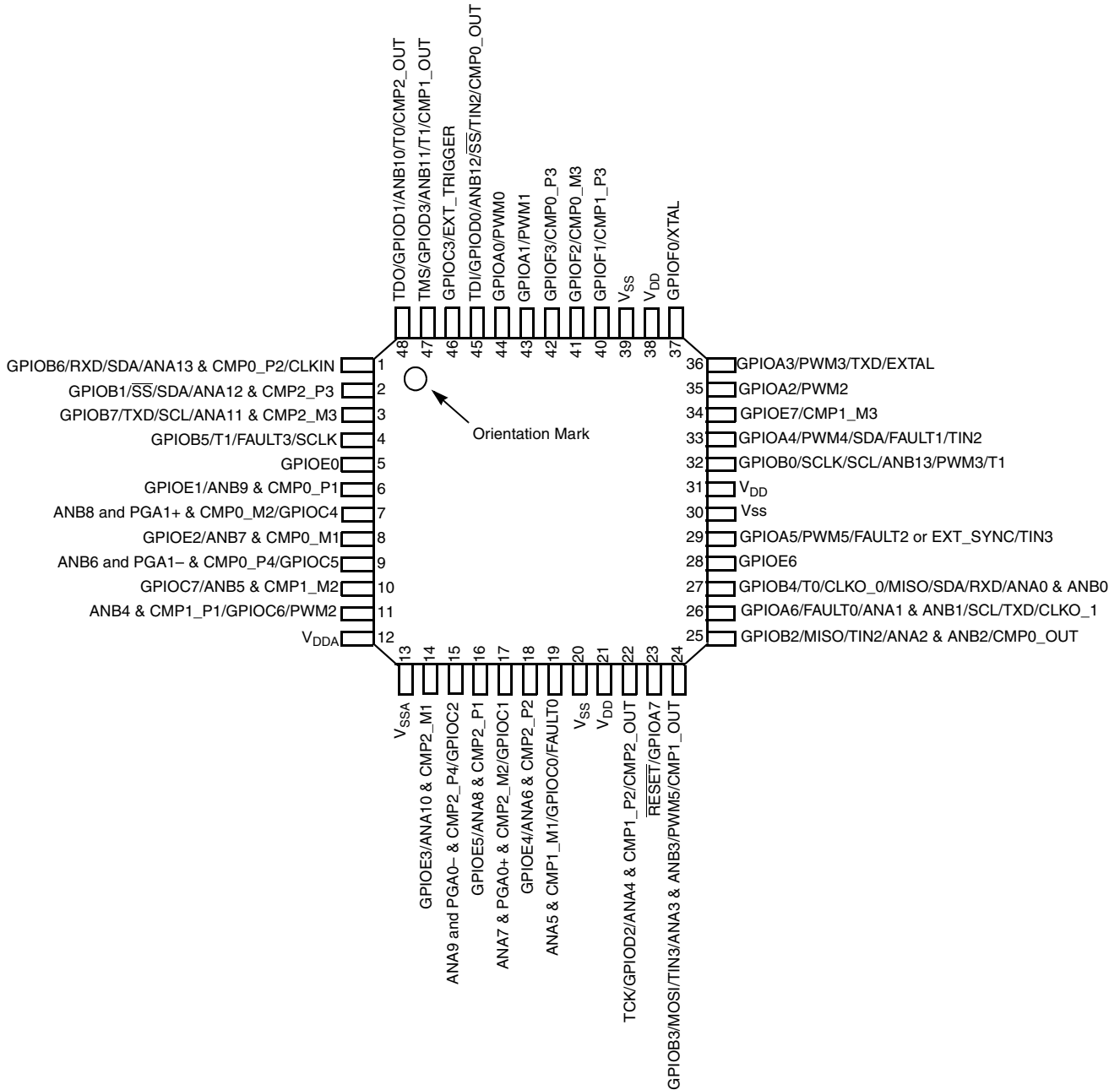

Figure 6. Top View, MC56F8006 48-Pin LQFP Package

4.3 56F8006/56F8002 Signal Pins

After reset, each pin is configured for its primary function (listed first). Any alternate functionality must be programmed via the GPIO module's peripheral enable registers (GPIO_x_PER) and SIM module's (GPS_xn) GPIO peripheral select registers. If CLKIN or XTAL is selected as device external clock input, the CLK_MOD bit in the OCCS oscillator control register (OSCTL) needs to be set too. EXT_SEL bit in OSCTL selects CLKIN or XTAL.

Table 5. 56F8006/56F8002 Signal and Package Information

Signal Name	28 SOIC	32 LQFP	48 LQFP	Type	State During Reset	Signal Description
V _{DD}			21	Supply	Supply	I/O Power — This pin supplies 3.3 V power to the chip I/O interface.
V _{DD}			31			
V _{DD}	19	26	38			
V _{SS}	8	13	20	Supply	Supply	I/O Ground — These pins provide ground for chip I/O interface.
V _{SS}			30			
V _{SS}	20	27	39			
V _{DDA}	3	8	12	Supply	Supply	Analog Power — This pin supplies 3.3 V power to the analog modules. It must be connected to a clean analog power supply.
V _{SSA}	4	9	13	Supply	Supply	Analog Ground — This pin supplies an analog ground to the analog modules. It must be connected to a clean power supply.
$\overline{\text{RESET}}$ (GPIOA7)	10	15	23	Input Input/ Output	Input, internal pullup enabled	<p>Reset — This input is a direct hardware reset on the processor. When $\overline{\text{RESET}}$ is asserted low, the device is initialized and placed in the reset state. A Schmitt-trigger input is used for noise immunity. The internal reset signal is deasserted synchronous with the internal clocks after a fixed number of internal clocks.</p> <p>Port A GPIO — This GPIO pin can be individually programmed as an input or output pin. $\overline{\text{RESET}}$ functionality is disabled in this mode and the chip can be reset only via POR, COP reset, or software reset.</p> <p>After reset, the default state is $\overline{\text{RESET}}$.</p>
GPIOA0 (PWM0)	22	29	44	Input/ Output Output	Input, internal pullup enabled	<p>Port A GPIO — This GPIO pin can be individually programmed as an input or output pin.</p> <p>PWM0 — The PWM channel 0.</p> <p>After reset, the default state is GPIOA0.</p>
GPIOA1 (PWM1)	21	28	43	Input/ Output Output	Input, internal pullup enabled	<p>Port A GPIO — This GPIO pin can be individually programmed as an input or output pin.</p> <p>PWM1 — The PWM channel 1.</p> <p>After reset, the default state is GPIOA1.</p>
GPIOA2 (PWM2)		23	35	Input/ Output Output	Input, internal pullup enabled	<p>Port A GPIO — This GPIO pin can be individually programmed as an input or output pin.</p> <p>PWM2 — The PWM channel 2.</p> <p>After reset, the default state is GPIOA2.</p>

Table 5. 56F8006/56F8002 Signal and Package Information (continued)

Signal Name	28 SOIC	32 LQFP	48 LQFP	Type	State During Reset	Signal Description
GPIOA3 (PWM3) (TXD) (EXTAL)	17	24	36	Input/ Output Output Analog Input	Input, internal pullup enabled	<p>Port A GPIO — This GPIO pin can be individually programmed as an input or output pin.</p> <p>PWM3 — The PWM channel 3.</p> <p>TXD — The SCI transmit data output or transmit/receive in single wire operation.</p> <p>EXTAL — External Crystal Oscillator Input. This input can be connected to a 32.768 kHz or 1–16 MHz external crystal or ceramic resonator. When used to supply a source to the internal PLL, the crystal/resonator must be in the 4 MHz to 8 MHz range. Tie this pin low or configure as GPIO if XTAL is being driven by an external clock source.</p> <p>If using a 32.768 kHz crystal, place the crystal as close as possible to device pins to speed startup.</p> <p>After reset, the default state is GPIOA3.</p>
GPIOA4 (PWM4) (SDA) (FAULT1) (TIN2)	16	22	33	Input/ Output Input/Open -drain Output Input Input	Input, internal pullup enabled	<p>Port A GPIO — This GPIO pin can be individually programmed as an input or output pin.</p> <p>PWM4 — The PWM channel 4.</p> <p>SDA — The I²C serial data line.</p> <p>FAULT1 — PWM fault input 1 used for disabling selected PWM outputs in cases where fault conditions originate off-chip.</p> <p>TIN2 — Dual timer module channel 2 input</p> <p>After reset, the default state is GPIOA4.</p>
GPIOA5 (PWM5) (FAULT2/ EXT_SYNC) (TIN3)	14	20	29	Input/ Output Output Input/ Output Input	Input, internal pullup enabled	<p>Port A GPIO — This GPIO pin can be individually programmed as an input or output pin.</p> <p>PWM5 — The PWM channel 5.</p> <p>FAULT2 — PWM fault input 2 used for disabling selected PWM outputs in cases where fault conditions originate off-chip.</p> <p>EXT_SYNC — When not being used as a fault input, this pin can be used to receive a pulse to reset the PWM counter or to generate a positive pulse at the start of every PWM cycle.</p> <p>TIN3 — Dual timer module channel 3 input</p> <p>After reset, the default state is GPIOA5.</p>

Table 5. 56F8006/56F8002 Signal and Package Information (continued)

Signal Name	28 SOIC	32 LQFP	48 LQFP	Type	State During Reset	Signal Description
GPIOA6 (FAULT0) (ANA1 & ANB1) (SCL) (TXD) (CLKO_1)	12	18	26	Input/Output Input Analog Input Input/Open-drain Output Output Output	Input, internal pullup enabled	<p>Port A GPIO — This GPIO pin can be individually programmed as an input or output pin.</p> <p>FAULT0 — PWM fault input 0 used for disabling selected PWM outputs in cases where fault conditions originate off-chip.</p> <p>ANA1 and ANB1 — Analog input to channel 1 of ADCA and ADCB.</p> <p>SCL — The I²C serial clock</p> <p>TXD — The SCI transmit data output or transmit/receive in single wire operation.</p> <p>CLKO_1 — This is a buffered clock output; the clock source is selected by clockout select (CLKOSEL) bits in the clock output select register (CLKOUT) in the SIM.</p> <p>When used as an analog input, the signal goes to the ANA1 and ANB1.</p> <p>After reset, the default state is GPIOA6.</p>
GPIOB0 (SCLK) (SCL) (ANB13) (PWM3) (T1)	15	21	32	Input/Output Input/Output Input/Open-drain Output Analog Input Output Input/Output	Input, internal pullup enabled	<p>Port B GPIO — This GPIO pin can be individually programmed as an input or output pin.</p> <p>SCLK — The SPI serial clock. In master mode, this pin serves as an output, clocking slaved listeners. In slave mode, this pin serves as the data clock input.</p> <p>SCL — The I²C serial clock.</p> <p>ANB13 — Analog input to channel 13 of ADCB</p> <p>PWM3 — The PWM channel 3.</p> <p>T1 — Dual timer module channel 1 input/output.</p> <p>After reset, the default state is GPIOB0.</p>

Table 5. 56F8006/56F8002 Signal and Package Information (continued)

Signal Name	28 SOIC	32 LQFP	48 LQFP	Type	State During Reset	Signal Description
GPIOB1 (\overline{SS}) (SDA) (ANA12 and CMP2_P3)	27	2	2	Input/Output Input/Output Input/Open-drain Output Analog input	Input, internal pullup enabled	Port B GPIO — This GPIO pin can be individually programmed as an input or output pin. \overline{SS} — \overline{SS} is used in slave mode to indicate to the SPI module that the current transfer is to be received. SDA — The I ² C serial data line. ANA12 and CMP2_P3 — Analog input to channel 12 of ADCA and Positive input 3 of analog comparator 2. When used as an analog input, the signal goes to the ANA12 and CMP2_P3. After reset, the default state is GPIOB1.
GPIOB2 (MISO) (TIN2) (ANA2 and ANB2) (CMP0_OUT)		17	25	Input/Output Input/Output Input/Output Analog Input Output	Input, internal pullup enabled	Port B GPIO — This GPIO pin can be individually programmed as an input or output pin. MISO — Master in/slave out. In master mode, this pin serves as the data input. In slave mode, this pin serves as the data output. The MISO line of a slave device is placed in the high-impedance state if the slave device is not selected. TIN2 — Dual timer module channel 2 input. ANA2 and ANB2 — Analog input to channel 2 of ADCA and ADCB. CMP0_OUT — Analog comparator 0 output. When used as an analog input, the signal goes to the ANA2 and ANB2. After reset, the default state is GPIOB2.

Table 5. 56F8006/56F8002 Signal and Package Information (continued)

Signal Name	28 SOIC	32 LQFP	48 LQFP	Type	State During Reset	Signal Description
GPIOB3 (MOSI) (TIN3) (ANA3 and ANB3) (PWM5) (CMP1_OUT)	11	16	24	Input/Output Input/Output Input/Output Input Output Output	Input, internal pullup enabled	<p>Port B GPIO — This GPIO pin can be individually programmed as an input or output pin.</p> <p>MOSI — Master out/slave in. In master mode, this pin serves as the data output. In slave mode, this pin serves as the data input.</p> <p>TIN3 — Dual timer module channel 3 input.</p> <p>ANA3 and ANB3 — Analog input to channel 3 of ADCA and ADCB.</p> <p>PWM5 — The PWM channel 5.</p> <p>CMP1_OUT— Analog comparator 1 output.</p> <p>When used as an analog input, the signal goes to the ANA3 and ANB3.</p> <p>After reset, the default state is GPIOB3.</p>
GPIOB4 (T0) (CLKO_0) (MISO) (SDA) (RXD) (ANA0 and ANB0)	13	19	27	Input/Output Input/Output Output Input/Output Input/Open-drain Output Input Analog Input	Input, internal pullup enabled	<p>Port B GPIO — This GPIO pin can be individually programmed as an input or output pin.</p> <p>T0 — Dual timer module channel 0 input/output.</p> <p>CLKO_0 — This is a buffered clock output; the clock source is selected by clockout select (CLKOSEL) bits in the clock output select register (CLKOUT) of the SIM.</p> <p>MISO — Master in/slave out. In master mode, this pin serves as the data input. In slave mode, this pin serves as the data output. The MISO line of a slave device is placed in the high-impedance state if the slave device is not selected.</p> <p>SDA — The I²C serial data line.</p> <p>RXD — The SCI receive data input.</p> <p>ANA0 and ANB0 — Analog input to channel 0 of ADCA and ADCB.</p> <p>When used as an analog input, the signal goes to the ANA0 and ANB0.</p> <p>After reset, the default state is GPIOB4.</p>

Table 5. 56F8006/56F8002 Signal and Package Information (continued)

Signal Name	28 SOIC	32 LQFP	48 LQFP	Type	State During Reset	Signal Description
GPIOB5 (T1) (FAULT3) (SCLK)		4	4	Input/Output Input/Output Input Input	Input, internal pullup enabled	Port B GPIO — This GPIO pin can be individually programmed as an input or output pin. T1 — Dual timer module channel 1 input/output. FAULT3 — PWM fault input 3 used for disabling selected PWM outputs in cases where fault conditions originate off-chip. SCLK — SPI serial clock. In master mode, this pin serves as an output, clocking slaved listeners. In slave mode, this pin serves as the data clock input. After reset, the default state is GPIOB5.
GPIOB6 (SDA) (ANA13 and CMP0_P2) (CLKIN)	26	1	1	Input/Output Input/Open-drain Output Analog Input Input	Input, internal pullup enabled	Port B GPIO — This GPIO pin can be individually programmed as an input or output pin. SDA — The I ² C serial data line. ANA13 and CMP0_P2 — Analog input to channel 13 of ADCA and positive input 2 of analog comparator 0. External Clock Input — This pin serves as an external clock input. When used as an analog input, the signal goes to the ANA13 and CMP0_P2. After reset, the default state is GPIOB6.
GPIOB7 (TXD) (SCL) (ANA11 and CMP2_M3)		3	3	Input/Output Input/Output Input/Open-drain Output Analog Input	Input, internal pullup enabled	Port B GPIO — This GPIO pin can be individually programmed as an input or output pin. TXD — The SCI transmit data output or transmit/receive in single wire operation. SCL — The I ² C serial clock. ANA11 and CMP2_M3 — Analog input to channel 11 of ADCA and negative input 3 of analog comparator 2. When used as an analog input, the signal goes to the ANA11 and CMP2_M3. After reset, the default state is GPIOB7.

Table 5. 56F8006/56F8002 Signal and Package Information (continued)

Signal Name	28 SOIC	32 LQFP	48 LQFP	Type	State During Reset	Signal Description
ANA5 and CMP1_M1 (GPIOC0) (FAULT0)	7	12	19	Analog Input Analog Input Input	Analog Input	ANA5 and CMP1_M1— Analog input to channel 5 of ADCA and negative input 1 of analog comparator 1. Port C GPIO — This GPIO pin can be individually programmed as an input or output pin. FAULT0 — PWM fault input 0 is used for disabling selected PWM outputs in cases where fault conditions originate off-chip. When used as an analog input, the signal goes to the ANA5 and CMP1_M1. After reset, the default state is ANA5 and CMP1_M1.
ANA7 and PGA0+ and CMP2_M2 (GPIOC1)	6	11	17	Analog Input Input/Output	Analog Input	ANA7 and PGA0+ and CMP2_M2 — Analog input to channel 7 of ADCA and PGA0 positive input and negative input 2 of analog comparator 2. Port C GPIO — This GPIO pin can be individually programmed as an input or output pin. When used as an analog input, The signal goes to the ANA7 and PGA0+ and CMP2_M2. After reset, the default state is ANA7 and PGA0+ and CMP2_M2.
ANA9 and PGA0– and CMP2_P4 (GPIOC2)	5	10	15	Analog Input Input/Output	Analog Input	ANA9 and PGA0– and CMP2_P4 — Analog input to channel 9 of ADCA and PGA0 negative input and positive input 4 of analog comparator 2. Port C GPIO — This GPIO pin can be individually programmed as an input or output pin. When used as an analog input, The signal goes to the ANA9 and PGA0– and CMP2_P4. After reset, the default state is ANA9 and PGA0– and CMP2_P4.
GPIOC3 (EXT_TRIGGER)			46	Input/Output Input	Input, internal pullup enabled	Port C GPIO — This GPIO pin can be individually programmed as an input or output pin. EXT_TRIGGER — PDB external trigger input. After reset, the default state is GPIOC3.

Table 5. 56F8006/56F8002 Signal and Package Information (continued)

Signal Name	28 SOIC	32 LQFP	48 LQFP	Type	State During Reset	Signal Description
ANB8 and PGA1+ and CMP0_M2 (GPIOC4)	28	5	7	Analog Input Input/Output	Analog Input	ANB8 and PGA1+ and CMP0_M2 — Analog input to channel 8 of ADCB and PGA1 positive input and negative input 2 of analog comparator 0. Port C GPIO — This GPIO pin can be individually programmed as an input or output pin. When used as an analog input, the signal goes to the ANB8 and PGA1+ and CMP0_M2. After reset, the default state is ANB8 and PGA1+ and CMP0_M2.
ANB6 and PGA1– and CMP0_P4 (GPIOC5)	1	6	9	Input/Output Analog Input	Analog Input	ANB6 and PGA1– and CMP0_P4 — Analog input to channel 6 of ADCB and PGA1 negative input and positive input 4 of analog comparator 0. Port C GPIO — This GPIO pin can be individually programmed as an input or output pin. When used as an analog input, the signal goes to the ANB6 and PGA1– and CMP0_P4. After reset, the default state is ANB6 and PGA1– and CMP0_P4.
ANB4 and CMP1_P1 (GPIOC6) (PWM2)	2	7	11	Analog Input Input/Output Output	Analog Input	ANB4 and CMP1_P1 — Analog input to channel 4 of ADCB and positive input 1 of analog comparator 1. Port C GPIO — This GPIO pin can be individually programmed as an input or output pin. PWM2 — The PWM channel 2. When used as an analog input, the signal goes to the ANB4 and CMP1_P1. After reset, the default state is ANB4 and CMP1_P1.
GPIOC7 (ANB5 and CMP1_M2)			10	Input/Output Analog Input	Input, internal pullup enabled	Port C GPIO — This GPIO pin can be individually programmed as an input or output pin. ANB5 and CMP1_M2 — Analog input to channel 5 of ADCB and negative input 2 of analog comparator 1. After reset, the default state is GPIOC7.

Table 5. 56F8006/56F8002 Signal and Package Information (continued)

Signal Name	28 SOIC	32 LQFP	48 LQFP	Type	State During Reset	Signal Description
TDI (GPIOD0) (ANB12) (\overline{SS}) (TIN2) (CMP0_OUT)	23	30	45	Input Input/ Output Analog Input Input Input Output	Input, internal pullup enabled	<p>Test Data Input — This input pin provides a serial input data stream to the JTAG/EOnCE port. It is sampled on the rising edge of TCK and has an on-chip pullup resistor.</p> <p>Port D GPIO — This GPIO pin can be individually programmed as an input or output pin.</p> <p>ANB12 — Analog input to channel 12 of ADCB</p> <p>\overline{SS} — \overline{SS} is used in slave mode to indicate to the SPI module that the current transfer is to be received.</p> <p>TIN2 — Dual timer module channel 2 input.</p> <p>CMP1_OUT — Analog comparator 1 output.</p> <p>After reset, the default state is TDI.</p>
TDO (GPIOD1) (ANB10) (T0) (CMP2_OUT)	25	32	48	Output Input/ Output Analog Input Input/ Output Output	Output, tri-stated, internal pullup enabled	<p>Test Data Output — This three-stateable output pin provides a serial output data stream from the JTAG/EOnCE port. It is driven in the shift-IR and shift-DR controller states, and changes on the falling edge of TCK.</p> <p>Port D GPIO — This GPIO pin can be individually programmed as an input or output pin.</p> <p>ANB10 — Analog input to channel 10 of ADCB.</p> <p>T0 — Dual timer module channel 0 input/output.</p> <p>CMP2_OUT — Analog comparator 2 output.</p> <p>After reset, the default state is TDO.</p>
TCK (GPIOD2) (ANA4 and CMP1_P2) (CMP2_OUT)	9	14	22	Input Input/ Output Analog Input Output	Input, internal pullup enabled	<p>Test Clock Input — This input pin provides a gated clock to synchronize the test logic and shift serial data to the JTAG/EOnCE port. The pin is connected internally to a pullup resistor. A Schmitt-trigger input is used for noise immunity.</p> <p>Port D GPIO — This GPIO pin can be individually programmed as an input or output pin.</p> <p>ANA4 and CMP1_P2 — Analog input to channel 4 of ADCA and positive input 2 of analog comparator 1.</p> <p>CMP2_OUT — Analog comparator 2 output.</p> <p>After reset, the default state is TCK.</p>

Table 5. 56F8006/56F8002 Signal and Package Information (continued)

Signal Name	28 SOIC	32 LQFP	48 LQFP	Type	State During Reset	Signal Description
TMS (GPIOD3) (ANB11) (T1) (CMP1_OUT)	24	31	47	Input Input/ Output Analog Input Input/ Output Output	Input, internal pullup enabled	<p>Test Mode Select Input — This input pin is used to sequence the JTAG TAP controller's state machine. It is sampled on the rising edge of TCK and has an on-chip pullup resistor.</p> <p>Port D GPIO — This GPIO pin can be individually programmed as an input or output pin.</p> <p>ANB11 — Analog input to channel 11 of ADCB.</p> <p>T1 — Dual timer module channel 1 input/output.</p> <p>CMP1_OUT — Analog comparator 2 output.</p> <p>After reset, the default state is TMS.</p> <p>Always tie the TMS pin to VDD through a 2.2 kΩ resistor.</p>
GPIOE0			5	Input/ Output	Input, internal pullup enabled	<p>Port E GPIO — This GPIO pin can be individually programmed as an input or output pin.</p> <p>After reset, the default state is GPIOE0.</p>
GPIOE1 (ANB9 and CMP0_P1)			6	Input/ Output Analog Input	Input, internal pullup enabled	<p>Port E GPIO — This GPIO pin can be individually programmed as an input or output pin.</p> <p>ANB9 and CMP0_P1 — Analog input to channel 9 of ADCB and positive input 1 of analog comparator 0.</p> <p>After reset, the default state is GPIOE1.</p>
GPIOE2 (ANB7 and CMP0_M1)			8	Input/ Output Analog Input	Input, internal pullup enabled	<p>Port E GPIO — This GPIO pin can be individually programmed as an input or output pin.</p> <p>ANB7 and CMP0_M1 — Analog input to channel 7 of ADCB and negative input 1 of analog comparator 0.</p> <p>After reset, the default state is GPIOE2.</p>
GPIOE3 (ANA10 and CMP2_M1)			14	Input/ Output Analog Input	Input, internal pullup enabled	<p>Port E GPIO — This GPIO pin can be individually programmed as an input or output pin.</p> <p>ANA10 and CMP2_M1 — Analog input to channel 10 of ADCA and negative input 1 of analog comparator 2.</p> <p>After reset, the default state is GPIOE3.</p>
GPIOE4 (ANA6 and CMP2_P2)			18	Input/ Output Analog Input	Input, internal pullup enabled	<p>Port E GPIO — This GPIO pin can be individually programmed as an input or output pin.</p> <p>ANA6 and CMP2_P2 — Analog input to channel 6 of ADCA and positive input 2 of analog comparator 2.</p> <p>After reset, the default state is GPIOE4.</p>

Table 5. 56F8006/56F8002 Signal and Package Information (continued)

Signal Name	28 SOIC	32 LQFP	48 LQFP	Type	State During Reset	Signal Description
GPIOE5 (ANA8 and CMP2_P1)			16	Input/ Output Analog Input	Input, internal pullup enabled	Port E GPIO — This GPIO pin can be individually programmed as an input or output pin. ANA8 and CMP2_P1— Analog input to channel 8 of ADCA and positive input 1 of analog comparator 2. After reset, the default state is GPIOE5.
GPIOE6			28	Input/ Output	Input, internal pullup enable	Port E GPIO — This GPIO pin can be individually programmed as an input or output pin. After reset, the default state is GPIOE6.
GPIOE7 (CMP1_M3)			34	Input/ Output Analog Input	Input, internal pullup enabled	Port E GPIO — This GPIO pin can be individually programmed as an input or output pin CMP1_M3 — Analog input to both negative input 3 of analog comparator 1. After reset, the default state is GPIOE7.
GPIOF0 (XTAL)	18	25	37	Input/ Output Analog Input/ Output	Input, internal pullup enabled	Port F GPIO — This GPIO pin can be individually programmed as an input or output pin. XTAL — External Crystal Oscillator Output. This output connects the internal crystal oscillator output to an external crystal or ceramic resonator. After reset, the default state is GPIOF0.
GPIOF1 (CMP1_P3)			40	Input/ Output Analog Input	Input, internal pullup enabled	Port F GPIO — This GPIO pin can be individually programmed as an input or output pin CMP1_P3 — Analog input to both positive input 3 of analog comparator 1. After reset, the default state is GPIOF1
GPIOF2 (CMP0_M3)			41	Input/ Output Analog Input	Input, internal pullup enabled	Port F GPIO — This GPIO pin can be individually programmed as an input or output pin. CMP0_M3 — Analog input to both negative input 3 of analog comparator 0. After reset, the default state is GPIOF2.
GPIOF3 (CMP0_P3)			42	Input/ Output Analog Input	Input, internal pullup enabled	Port F GPIO — This GPIO pin can be individually programmed as an input or output pin. CMP0_P3 — Analog input to both positive input 3 of analog comparator 0. After reset, the default state is GPIOF3.

5 Memory Maps

5.1 Introduction

The 56F8006/56F8002 device is based on the 56800E core. It uses a dual Harvard-style architecture with two independent memory spaces for Data and Program. On-chip RAM is shared by both data and program spaces and flash memory is used only in program space.

This section provides memory maps for:

- Program address space, including the interrupt vector table
- Data address space, including the EOnCE memory and peripheral memory maps

On-chip memory sizes for the device are summarized in [Table 6](#). Flash memories' restrictions are identified in the "Use Restrictions" column of [Table 6](#).

Table 6. Chip Memory Configurations

On-Chip Memory	56F8006	56F8002	Use Restrictions
Program Flash (PFLASH)	8K x 16 or 16 KB	6K x 16 or 12 KB	Erase/program via flash interface unit and word writes to CDBW
Unified RAM (RAM)	1K x 16 or 2 KB	1K x 16 or 2 KB	Usable by the program and data memory spaces

5.2 Program Map

The 56F8006/56F8002 series provide up to 16 KB on-chip flash memory. It primarily accesses through the program memory buses (PAB; PDB). PAB is used to select program memory addresses; instruction fetches are performed over PDB. Data can be read and written to program memory space through primary data memory buses: CDBW for data write and CDBR for data read. Accessing program memory space over the data memory buses takes longer access time compared to accessing data memory space. The special MOVE instructions are provided to support these accesses. The benefit is that non time critical constants or tables can be stored and accessed in program memory.

The program memory map is shown in [Table 7](#) and [Table 8](#).

Table 7. Program Memory Map¹ for 56F8006 at Reset

Begin/End Address	Memory Allocation
P: 0x1F FFFF P: 0x00 8800	RESERVED
P: 0x00 83FF P: 0x00 8000	On-Chip RAM ² : 2 KB
P: 0x00 7FFF P: 0x00 2000	RESERVED
P: 0x00 1FFF P: 0x00 0000	<ul style="list-style-type: none"> • Internal program flash: 16 KB • Interrupt vector table locates from 0x00 0000 to 0x00 0065 • COP reset address = 0x00 0002 • Boot location = 0x00 0000

¹ All addresses are 16-bit word addresses.

² This RAM is shared with data space starting at address X: 0x00 0000; see [Figure 7](#).

Table 8. Program Memory Map¹ for 56F8002 at Reset (continued)

Begin/End Address	Memory Allocation
P: 0x1F FFFF P: 0x00 8800	RESERVED
P: 0x00 83FF P: 0x00 8000	On-Chip RAM ² : 2 KB
P: 0x00 7FFF P: 0x00 2000	RESERVED
P: 0x00 1FFF P: 0x00 0800	<ul style="list-style-type: none"> • Internal program flash: 12 KB • Interrupt vector table locates from 0x00 0800 to 0x00 0865 • COP reset address = 0x00 0802 • Boot location = 0x00 0800
P: 0x00 07FF P: 0x00 0000	RESERVED

¹ All addresses are 16-bit word addresses.

² This RAM is shared with data space starting at address X: 0x00 0000; see [Figure 8](#).

5.3 Data Map

The 56F8006/56F8002 series contain a dual access memory. It can be accessed from core primary data buses (XAB1; CDBW; CDBR) and secondary data buses (XAB2; XDB2). Addresses in data memory are selected on the XAB1 and XAB2 buses. Byte, word, and long data transfers occur on the 32-bit CDBR and CDBW buses. A second 16-bit read operation can be performed in parallel on the XDB2 bus.

Peripheral registers and on-chip JTAG/EOnCE controller registers are memory-mapped into data memory access. A special direct address mode is supported for accessing a first 64-location in data memory by using a single word instruction.

The data memory map is shown in [Table 9](#).

Table 9. Data Memory Map¹

Begin/End Address	Memory Allocation
X:0xFF FFFF X:0xFF FF00	EOnCE 256 locations allocated
X:0xFF FEFF X:0x01 0000	RESERVED
X:0x00 FFFF X:0x00 F000	On-Chip Peripherals 4096 locations allocated
X:0x00 EFFF X:0x00 8800	RESERVED
X:0x00 87FF X:0x00 8000	RESERVED
X:0x00 7FFF X:0x00 0400	RESERVED
X:0x00 03FF X:0x00 0000	On-Chip Data RAM 2 KB ²

¹ All addresses are 16-bit word addresses.

² This RAM is shared with Program space starting at P: 0x00 8000. See [Figure 7](#) and [Figure 8](#).

Memory Maps

On-chip RAM is also mapped into program space starting at P: 0x00 8000. This makes for easier online reprogramming of on-chip flash.

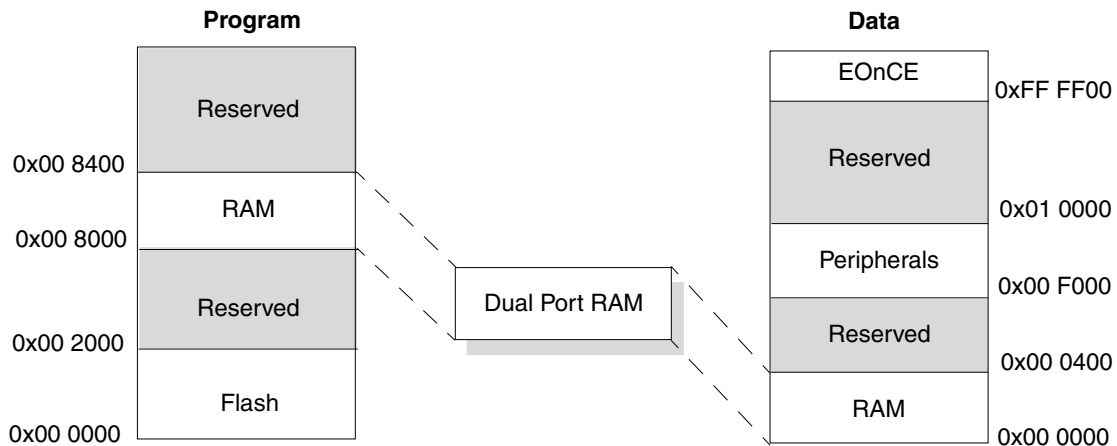

Figure 7. 56F8006 Dual Port RAM Map

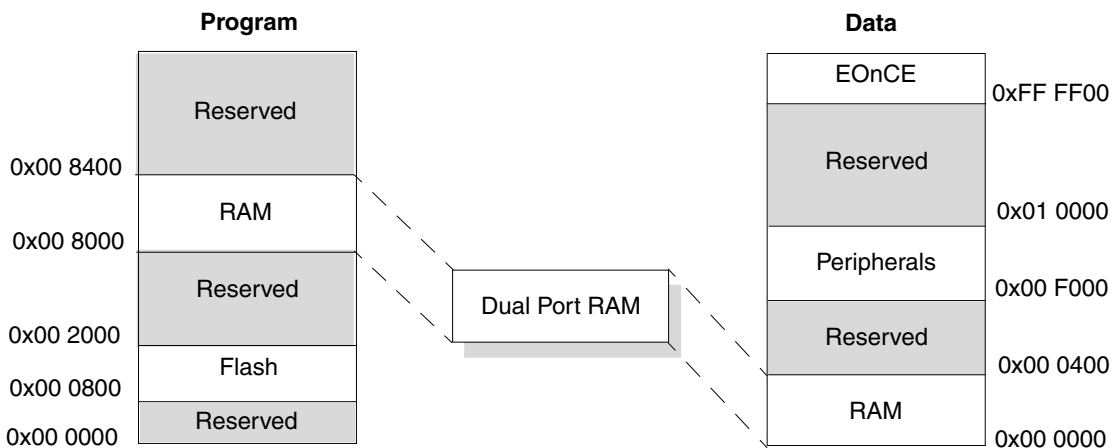

Figure 8. 56F8002 Dual Port RAM Map

5.4 Interrupt Vector Table and Reset Vector

The location of the vector table is determined by the vector base address register (VBA). The value in this register is used as the upper 14 bits of the interrupt vector VAB[20:0]. The lower seven bits are determined based on the highest priority interrupt and are then appended onto VBA before presenting the full VAB to the core. Please see the *MC56F8006 Peripheral Reference Manual* for detail. The reset startup addresses of 56F8002 and 56F8006 are different.

- 56F8006 startup address is located at 0x00 0000. The reset value of VBA is reset to a value of 0x0000 that corresponds to address 0x00 0000
- 56F8002 startup address is located at 0x00 0800. The reset value of VBA is reset to a value of 0x0010 that corresponds to address 0x00 0800

By default, the chip reset address and COP reset address correspond to vector 0 and 1 of the interrupt vector table. In these instances, the first two locations in the vector table must contain branch or JMP instructions. All other entries must contain JSR instructions.

The highest number vector, a user assignable vector USER6 (vector 50), can be defined as a fast interrupt if the instruction located in this vector location is not a JSR or BSR instruction. Please see section 9.3.3.3 of *DSP56800E 16-Bit Core Reference Manual* for detail.

Table 40 provides the 56F8006/56F8002's reset and interrupt priority structure, including on-chip peripherals.

5.5 Peripheral Memory-Mapped Registers

The locations of on-chip peripheral registers are part of the data memory map on the 56800E series. These locations may be accessed with the same addressing modes used for ordinary data memory, except all peripheral registers should be read or written using word accesses only.

Table 10 summarizes the base addresses for the set of peripherals on the 56F8006/56F8002 devices. Peripherals are listed in order of the base address.

Table 10. Data Memory Peripheral Base Address Map Summary

Peripheral	Prefix	Base Address
Dual Channel Timer	TMR	X:0x00 F000
PWM Module	PWM	X:0x00 F020
Interrupt Controller	INTC	X:0x00 F040
ADCA	ADCA	X:0x00 F060
ADCB	ADCB	X:0x00 F080
Programmable Gain Amplifier 0	PGA0	X:0x00 F0A0
Programmable Gain Amplifier 1	PGA1	X:0x00 F0C0
SCI	SCI	X:0x00 F0E0
SPI	SPI	X:0x00 F100
I ² C	I ² C	X:0x00 F120
Computer Operating Properly	COP	X:0x00 F140
On-Chip Clock Synthesis	OCCS	X:0x00 F160
GPIO Port A	GPIOA	X:0x00 F180
GPIO Port B	GPIOB	X:0x00 F1A0
GPIO Port C	GPIOC	X:0x00 F1C0
GPIO Port D	GPIOD	X:0x00 F1E0
GPIO Port E	GPIOE	X:0x00 F200
GPIO Port F	GPIOF	X:0x00 F220
System Integration Module	SIM	X:0x00 F240
Power Management Controller	PMC	X:0x00 F260
Analog Comparator 0	CMP0	X:0x00 F280
Analog Comparator 1	CMP1	X:0x00 F2A0
Analog Comparator 2	CMP2	X:0x00 F2C0
Programmable Interval Timer	PIT	X:0x00 F2E0
Programmable Delay Block	PDB	X:0x00 F300
Real Timer Clock	RTC	X:0x00 F320
Flash Memory Interface	FM	X:0x00 F400

5.6 EOnCE Memory Map

Control registers of the EOnCE are located at the top of data memory space. These locations are fixed by the 56F800E core. These registers can also be accessed through JTAG port if flash security is not set. [Table 11](#) lists all EOnCE registers necessary to access or control the EOnCE.

Table 11. EOnCE Memory Map

Address	Register Acronym	Register Name
X:0xFF FFFF	OTX1/ORX1	Transmit Register Upper Word Receive Register Upper Word
X:0xFF FFFE	OTX/ORX (32 bits)	Transmit Register Receive Register
X:0xFF FFFD	OTXRCSR	Transmit and Receive Status and Control Register
X:0xFF FFFC	OCLSR	Core Lock/Unlock Status Register
X:0xFF FFFB– X:0xFF FFA1		Reserved
X:0xFF FFA0	OCR	Control Register
X:0xFF FF9F– X:0xFF FF9E	OSCNTN (24 bits)	Instruction Step Counter
X:0xFF FF9D	OSR	Status Register
X:0xFF FF9C	OBASE	Peripheral Base Address Register
X:0xFF FF9B	OTBCR	Trace Buffer Control Register
X:0xFF FF9A	OTBPR	Trace Buffer Pointer Register
X:0xFF FF99– X:0xFF FF98	OTB (21–24 bits/stage)	Trace Buffer Register Stages
X:0xFF FF97– X:0xFF FF96	OBCR (24 bits)	Breakpoint Unit Control Register
X:0xFF FF95– X:0xFF FF94	OBAR1 (24 bits)	Breakpoint Unit Address Register 1
X:0xFF FF93– X:0xFF FF92	OBAR2 (32 bits)	Breakpoint Unit Address Register 2
X:0xFF FF91– X:0xFF FF90	OBMSK (32 bits)	Breakpoint Unit Mask Register 2
X:0xFF FF8F		Reserved
X:0xFF FF8E	OBCNTR	EOnCE Breakpoint Unit Counter
X:0xFF FF8D		Reserved
X:0xFF FF8C		Reserved
X:0xFF FF8B		Reserved
X:0xFF FF8A	OESCR	External Signal Control Register
X:0xFF FF89 – X:0xFF FF00		Reserved

6 General System Control Information

6.1 Overview

This section discusses power pins, reset sources, interrupt sources, clock sources, the system integration module (SIM), ADC synchronization, and JTAG/EOnCE interfaces.

6.2 Power Pins

V_{DD} , V_{SS} and V_{DDA} , V_{SSA} are the primary power supply pins for the devices. This voltage source supplies power to all on-chip peripherals, I/O buffer circuitry and to internal voltage regulators. Device has multiple internal voltages provide regulated lower-voltage source for the peripherals, core, memory, and on-chip relaxation oscillators.

Typically, there are at least two separate capacitors across the power pins to bypass the glitches and provide bulk charge storage. In this case, there should be a bulk electrolytic or tantalum capacitor, such as a 10 μF tantalum capacitor, to provide bulk charge storage for the overall system and a 0.1 μF ceramic bypass capacitor located as near to the device power pins as practical to suppress high-frequency noise. Each pin must have a bypass capacitor for best noise suppression.

V_{DDA} and V_{SSA} are the analog power supply pins for the device. This voltage source supplies power to the ADC, PGA, and CMP modules. A 0.1 μF ceramic bypass capacitor should be located as near to the device V_{DDA} and V_{SSA} pins as practical to suppress high-frequency noise. V_{DDA} and V_{SSA} are also the voltage reference high and voltage reference low inputs, respectively, for the ADC module.

6.3 Reset

Resetting the device provides a way to start processing from a known set of initial conditions. During reset, most control and status registers are forced to initial values and the program counter is loaded from the reset vector. On-chip peripheral modules are disabled and I/O pins are initially configured as the reset status shown in [Table 5](#). The 56F8006/56F8002 has the following sources for reset:

- Power-on reset (POR)
- Partial power down reset (PPD)
- Low-voltage detect (LVD)
- External pin reset (EXTR)
- Computer operating properly loss of reference reset (COP_LOR)
- Computer operating properly time-out reset (COP_CPU)
- Software Reset (SWR)

Each of these sources has an associated bit in the reset status register (RSTAT) in the system integration module (SIM).

The external pin reset function is shared with an GPIO port A7 on the $\overline{\text{RESET}}$ /GPIOA7 pin. The reset function is enabled following any reset of the device. Bit 7 of GPIOA_PER register must be cleared to use this pin as an GPIO port pin. When enabled as the $\overline{\text{RESET}}$ pin, an internal pullup device is automatically enabled.

6.4 On-chip Clock Synthesis

The on-chip clock synthesis (OCCS) module allows designers using an internal relaxation oscillator, an external crystal, or an external clock to run 56F8000 family devices at user-selectable frequencies up to 32 MHz.

The features of OCCS module include:

- Ability to power down the internal relaxation oscillator or crystal oscillator
- Ability to put the internal relaxation oscillator into standby mode
- Ability to power down the PLL

General System Control Information

- Provides a 3X system clock that operates at three times the system clock to PWM, timer, and SCI modules
- Safety shutdown feature is available if the PLL reference clock is lost
- Can be driven from an external clock source

The clock generation module provides the programming interface for the PLL, internal relaxation oscillator, and crystal oscillator. It also provides a postscaler to divide clock frequency down by 1, 2, 4, 8, 16, 32, 64, 128, 256 before feeding to the SIM. The SIM is responsible for further dividing these frequencies by two, which ensures a 50% duty cycle in the system clock output. For detail, see the OCCS chapter in the *MC56F8006 Peripheral Reference Manual*.

6.4.1 Internal Clock Source

An internal relaxation oscillator can supply the reference frequency when an external frequency source or crystal is not used. It is optimized for accuracy and programmability while providing several power-saving configurations that accommodate different operating conditions. The internal relaxation oscillator has little temperature and voltage variability. To optimize power, the internal relaxation oscillator supports a run state (8 MHz), standby state (400 kHz), and a power-down state.

During a boot or reset sequence, the relaxation oscillator is enabled by default (the PRECS bit in the PLLCR word is set to 0). Application code can then also switch to the external clock source and power down the internal oscillator, if desired. If a changeover between internal and external clock sources is required at power-on, ensure that the clock source is not switched until the desired external clock source is enabled and stable.

To compensate for variances in the device manufacturing process, the accuracy of the relaxation oscillator can be incrementally adjusted to within + 0.078% of 8 MHz by trimming an internal capacitor. Bits 0–9 of the OSCTL (oscillator control) register allow you to set in an additional offset (trim) to this preset value to increase or decrease capacitance. Each unit added or subtracted changes the output frequency by about 0.078% of 8 MHz, allowing incremental adjustment until the desired frequency accuracy is achieved.

The center frequency of the internal oscillator is calibrated at the factory to 8 MHz and the TRIM value is stored in the flash information block and loaded to the FMOPT1 register at reset. When using the relaxation oscillator, the boot code should read the FMOPT1 register and set this value as OSCTL TRIM. For further information, see the *MC56F8006 Peripheral Reference Manual*.

6.4.2 Crystal Oscillator/Ceramic Resonator

The internal crystal oscillator circuit is designed to interface with a parallel-resonant crystal resonator in the frequency range, specified for the external crystal, of 32.768 kHz (Typ) or 1–16 MHz. A ceramic resonator can be substituted for the 1–16 MHz range. When used to supply a source to the internal PLL, the recommended crystal/resonator is in the 4 MHz to 8 MHz (recommend 8 MHz) range to achieve optimized PLL performance. Oscillator circuits are shown in [Figure 9](#), [Figure 10](#), and [Figure 11](#). Follow the crystal supplier's recommendations when selecting a crystal, because crystal parameters determine the component values required to provide maximum stability and reliable start-up. The load capacitance values used in the oscillator circuit design should include all stray layout capacitances. The crystal and associated components should be mounted as near as possible to the EXTAL and XTAL pins to minimize output distortion and start-up stabilization time. When using low-frequency, low-power mode, the only external component is the crystal itself. In the other oscillator modes, load capacitors (C_x , C_y) and feedback resistor (R_F) are required. In addition, a series resistor (R_S) may be used in high-gain modes. Recommended component values are listed in [Table 27](#).

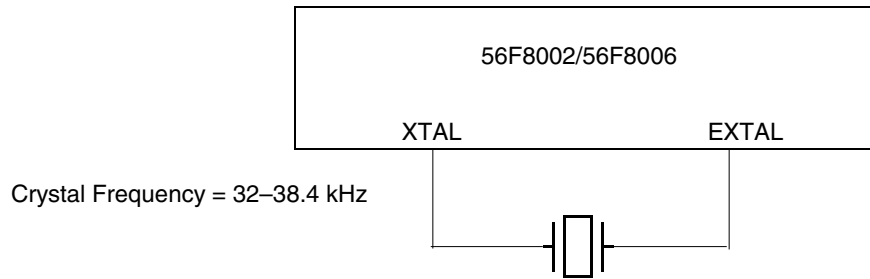

Figure 9. Typical Crystal Oscillator Circuit: Low-Range, Low-Power Mode

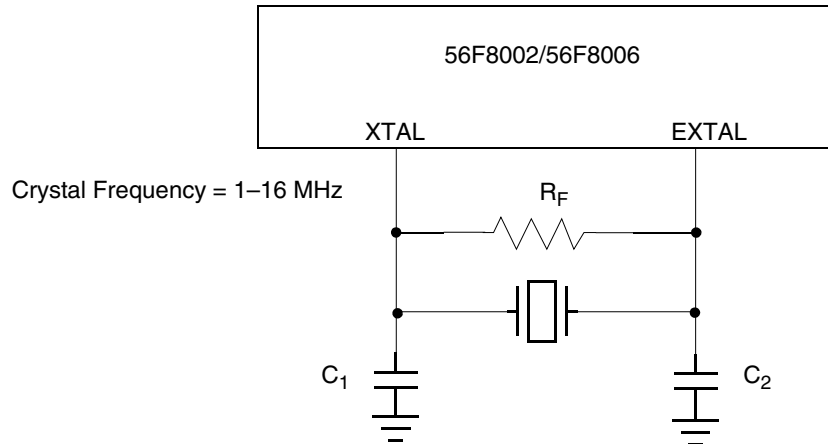

Figure 10. Typical Crystal or Ceramic Resonator Circuit: High-Range, Low-Power Mode

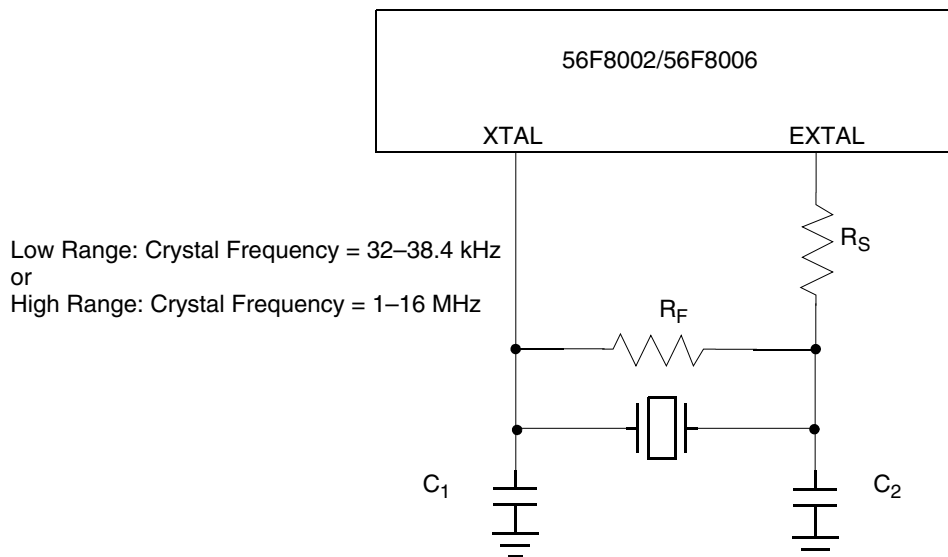

Figure 11. Typical Crystal or Ceramic Resonator Circuit: Low Range and High Range, High-Gain Mode

6.4.3 External Clock Input — Crystal Oscillator Option

The recommended method of connecting an external clock is illustrated in [Figure 12](#). The external clock source is connected to XTAL and the EXTAL pin is grounded or configured as GPIO while CLK_MOD bit in OSCTL register is set. The external clock input must be generated using a relatively low impedance driver with maximum frequency less than 8 MHz.

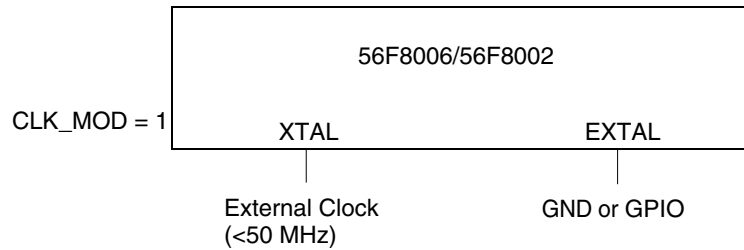

Figure 12. Connecting an External Clock Signal Using XTAL

6.4.4 Alternate External Clock Input

The recommended method of connecting an external clock is illustrated in Figure 13. The external clock source is connected to GPIOB6/RXD/SDA/ANA13 and CMP0_P2/CLKIN while EXT_SEL bit in OSCTL register is set and corresponding bits in GPIOB_PER register GPIO module and GPSB1 register in the system integration module (SIM) are set to the correct values. The external clock input must be generated using a relatively low impedance driver with maximum frequency not greater than 64 MHz.

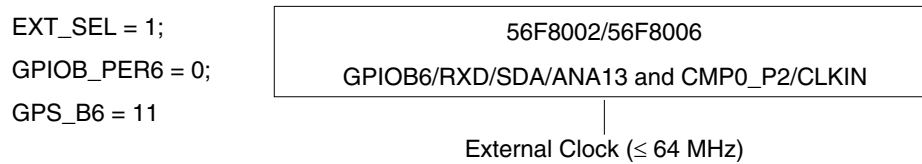

Figure 13. Connecting an External Clock Signal Using GPIO

6.5 Interrupt Controller

The 56F8006/56F8002 interrupt controller (INTC) module arbitrates the various interrupt requests (IRQs). The INTC signals to the 56800E core when an interrupt of sufficient priority exists and what address to jump to to service this interrupt.

The interrupt controller contains registers that allow up to three interrupt sources to be set to priority level 1 and other up to three interrupt sources to be set to priority level 2. By default, all peripheral interrupt sources are set to priority level 0. Next, all of the interrupt requests of a given level are priority encoded to determine the lowest numeric value of the active interrupt requests for that level. Within a given priority level, the lowest vector number is the highest priority and the highest vector number is the lowest.

The highest vector number, a user assignable vector USER6 (vector 50), can be defined as a fast interrupt if the instruction located in this vector location is not a JSR or BSR instruction. Please see section 9.3.3.3 of *DSP56800E 16-Bit Core Reference Manual* for detail.

6.6 System Integration Module (SIM)

The SIM module is a system catchall for the glue logic that ties together the system-on-chip. It controls distribution of resets and clocks and provides a number of control features including the pin muxing control; inter-module connection control (for example connecting comparator output to PWM fault input); individual peripheral enable/disable; PWM, timer, and SCI clock rate control; enabling peripheral operation in stop mode; port configuration overwrite protection. For further information, see the *MC56F8006 Peripheral Reference Manual*.

The SIM is responsible for the following functions:

- Chip reset sequencing
- Core and peripheral clock control and distribution
- Stop/wait mode control
- System status control

- Registers containing the JTAG ID of the chip
- Controls for programmable peripheral and GPIO connections
- Peripheral clocks for TMR and PWM and SCI with a high-speed (3X) option
- Power-saving clock gating for peripherals
- Controls the enable/disable functions of large regulator standby mode with write protection capability
- Permits selected peripherals to run in stop mode to generate stop recovery interrupts
- Controls for programmable peripheral and GPIO connections
- Software chip reset
- I/O short address base location control
- Peripheral protection control to provide runaway code protection for safety-critical applications
- Controls output of internal clock sources to CLKO pin
- Four general-purpose software control registers are reset only at power-on
- Peripherals stop mode clocking control

6.7 PWM, PDB, PGA, and ADC Connections

The comparators, timers, and PWM_reload_sync output can be connected to the programmable delay block (PDB) trigger input. The PDB pre-trigger A and trigger A outputs are connected to the ADCA and PGA0 hardware trigger inputs. The PDB pre-trigger B and trigger B outputs are connected to the ADCB and PGA1 hardware trigger inputs. When the input trigger of PDB is asserted, PDB trigger and pre-trigger outputs are asserted after a delay of a pre-programmed period. See the *MC56F8006 Peripheral Reference Manual* for additional information.

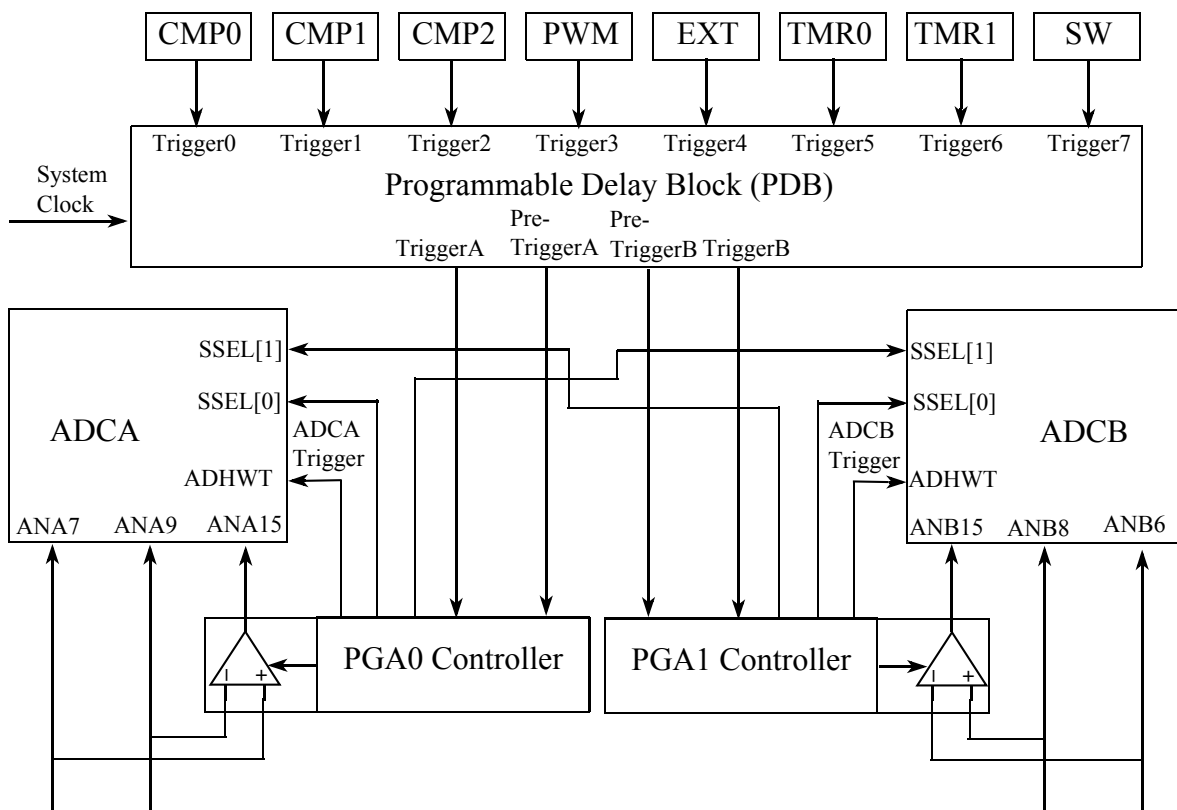

Figure 14. Synchronization of ADC, PDB

Security Features

Each ADC contains a temperature sensor. Outputs of temperature sensors, PGAs, on-chip regulators and VDDA are internally routed to ADC inputs.

- Internal PGA0 output available on ANA15
- Internal PGA0 positive input calibration voltage available on ANA16
- Internal PGA0 negative input calibration voltage available on ANA17
- Internal PGA1 output available on ANB15
- Internal PGA1 positive input calibration voltage available on ANB16
- Internal PGA1 negative input calibration voltage available on ANB17
- ADCA temperature sensor available on ANA26
- ADCB temperature sensor available on ANB26
- Output of on-chip digital voltage regulator is routed to ANA24 and ANB24
- Output of on-chip analog voltage regulator is routed to ANA25 and ANB25
- VDDA is routed to ANA27 and ANB27

6.8 Joint Test Action Group (JTAG)/Enhanced On-Chip Emulator (EOnCE)

The DSP56800E Family includes extensive integrated support for application software development and real-time debugging. Two modules, the Enhanced On-Chip Emulation module (EOnCE) and the core test access port (TAP, commonly called the JTAG port), work together to provide these capabilities. Both are accessed through a common 4-pin JTAG/EOnCE interface. These modules allow you to insert the 56F8006/56F8002 into a target system while retaining debug control. This capability is especially important for devices without an external bus, because it eliminates the need for a costly cable to bring out the footprint of the chip, as is required by a traditional emulator system.

The DSP56800E EOnCE module is a Freescale-designed module used to develop and debug application software used with the chip. This module allows non-intrusive interaction with the CPU and is accessible through the pins of the JTAG interface or by software program control of the DSP56800E core. Among the many features of the EOnCE module is the support for data communication between the controller and the host software development and debug systems in real-time program execution. Other features allow for hardware breakpoints, the monitoring and tracking of program execution, and the ability to examine and modify the contents of registers, memory, and on-chip peripherals, all in a special debug environment. No user-accessible resources need to be sacrificed to perform debugging operations.

The DSP56800E JTAG port is used to provide an interface for the EOnCE module to the DSP JTAG pins. Joint Test Action Group (JTAG) boundary scan is an IEEE 1149.1 standard methodology enabling access to test features using a test access port (TAP). A JTAG boundary scan consists of a TAP controller and boundary scan registers. Please contact your Freescale sales representative or authorized distributor for device-specific BSDL information.

NOTE

In normal operation, an external pullup on the TMS pin is highly recommend to place the JTAG state machine in reset state if this pin is not configured as GPIO.

7 Security Features

The 56F8006/56F8002 offers security features intended to prevent unauthorized users from reading the contents of the flash memory (FM) array. The 56F8006/56F8002's flash security consists of several hardware interlocks that prevent unauthorized users from gaining access to the flash array.

After flash security is set, an authorized user can be enabled to access on-chip memory if a user-defined software subroutine, which reads and transfers the contents of internal memory via peripherals, is included in the application software. This application software could communicate over a serial port, for example, to validate the authenticity of the requested access, then grant it until the next device reset. The inclusion of such a back door technique is at the discretion of the system designer.

7.1 Operation with Security Enabled

After you have programmed flash with the application code, or as part of the programming of the flash with the application code, the 56F8006/56F8002 can be secured by programming the security word, 0x0002, into program memory location 0x001FF7. This can also be effected by use of the CodeWarrior IDE menu flash lock command. This nonvolatile word keeps the device secured after reset, caused, for example, by a power-down of the device. Refer to the flash memory chapter in the *MC56F8006 Peripheral Reference Manual* for detail. When flash security mode is enabled, the 56F8006/56F8002 disables the core EOnCE debug capabilities. Normal program execution is otherwise unaffected.

7.2 Flash Access Lock and Unlock Mechanisms

There are several methods that effectively lock or unlock the on-chip flash.

7.2.1 Disabling EOnCE Access

On-chip flash can be read by issuing commands across the EOnCE port, which is the debug interface for the 56800E CPU. The TCK, TMS, TDO, and TDI pins comprise a JTAG interface onto which the EOnCE port functionality is mapped. When the device boots, the chip-level JTAG TAP (test access port) is active and provides the chip's boundary scan capability and access to the ID register, but proper implementation of flash security blocks any attempt to access the internal flash memory via the EOnCE port when security is enabled. This protection is effective when the device comes out of reset, even prior to the execution of any code at startup.

7.2.2 Flash Lockout Recovery Using JTAG

If the device is secured, one lockout recovery mechanism is the complete erasure of the internal flash contents, including the configuration field, thus disabling security (the protection register is cleared). This does not compromise security, as the entire contents of your secured code stored in flash are erased before security is disabled on the device on the next reset or power-up sequence.

To start the lockout recovery sequence via JTAG, the JTAG public instruction (LOCKOUT_RECOVERY) must first be shifted into the chip-level TAP controller's instruction register. After the LOCKOUT_RECOVERY instruction has been shifted into the instruction register, the clock divider value must be shifted into the corresponding 7-bit data register. After the data register has been updated, you must transition the TAP controller into the RUN-TEST/IDLE state for the lockout sequence to commence. The controller must remain in this state until the erase sequence is complete. Refer to the *MC56F8006 Peripheral Reference Manual* for detail, or contact Freescale.

NOTE

After the lockout recovery sequence has completed, you must reset the JTAG-TAP controller and device to return to normal unsecured operation. Power-on reset resets both too.

7.2.3 Flash Lockout Recovery Using CodeWarrior

CodeWarrior can unlock a device by selecting the *Debug* menu, then selecting *DSP56800E*, followed by *Unlock Flash*. Another mechanism is also built into CodeWarrior using the device's memory configuration file. The command "*Unlock_Flash_on_Connect 1*" in the *.cfg* file accomplishes the same task as using the *Debug* menu.

This lockout recovery mechanism is the complete erasure of the internal flash contents, including the configuration field, thus disabling security (the protection register is cleared).

7.2.4 Flash Lockout Recovery without Mass Erase

7.2.4.1 Without Presenting Back Door Access Keys to the Flash Unit

A user can un-secure a secured device by programming the word 0x0000 into program flash location 0x00 1FF7. After completing the programming, the JTAG TAP controller and the device must be reset to return to normal unsecured operation.

You are responsible for directing the device to invoke the flash programming subroutine to reprogram the word 0x0000 into program flash location 0x00 1FF7. This is done by, for example, toggling a specific pin or downloading a user-defined key through serial interfaces.

NOTE

Flash contents can be programmed only from 1s to 0s.

7.2.4.2 Presenting Back Door Access Key to the Flash Unit

It is possible to temporarily bypass the security through a back door access scheme, using a 4-word key, to temporarily unlock of the flash. A back door access requires support from the embedded software. This software would typically permit an external user to enter a four word code through one of the communications interfaces and then use it to attempt the unlock sequence. If your input matches the four word code stored at location 0x00 1FFC–0x00 1FFF in the flash memory, the part immediately becomes unsecured (at runtime) and you can access internal memory via JTAG/EOnCE port. Refer to the *MC56F8006 Peripheral Reference Manual* for detail. The key must be entered in four consecutive accesses to the flash, so this routine should be designed to run in RAM.

7.3 Product Analysis

The recommended method of unsecuring a secured device for product analysis of field failures is via the method described in [Section 7.2.4.2, “Presenting Back Door Access Key to the Flash Unit.”](#) The customer would need to supply technical support with the details of the protocol to access the subroutines in flash memory. An alternative method for performing analysis on a secured device would be to mass-erase and reprogram the flash with the original code, but modify the security word or not program the security word.

8 Specifications

8.1 General Characteristics

The 56F8006/56F8002 is fabricated in high-density low power and low leakage CMOS with a maximum voltage of 3.6 V digital inputs during normal operation without causing damage.

Absolute maximum ratings in [Table 12](#) are stress ratings only, and functional operation at the maximum is not guaranteed. Stress beyond these ratings may affect device reliability or cause permanent damage to the device.

Unless otherwise stated, all specifications within this chapter apply over the temperature range of –40°C to 105°C ambient temperature over the following supply ranges: $V_{SS} = V_{SSA} = 0V$, $V_{DD} = V_{DDA} = 3.0\text{--}3.6 V$, $CL \leq 50 pF$, $f_{OP} = 32 MHz$

CAUTION

This device contains protective circuitry to guard against damage due to high static voltage or electrical fields. However, normal precautions are advised to avoid application of any voltages higher than maximum-rated voltages to this high-impedance circuit. Reliability of operation is enhanced if unused inputs are tied to an appropriate voltage level.

8.2 Absolute Maximum Ratings

Absolute maximum ratings are stress ratings only, and functional operation at the maxima is not guaranteed. Stress beyond the limits specified Table 12 may affect device reliability or cause permanent damage to the device. For functional operating conditions, refer to the remaining tables in this section.

This device contains circuitry protecting against damage due to high static voltage or electrical fields; however, take normal precautions to avoid application of any voltages higher than maximum-rated voltages to this high-impedance circuit. Reliability of operation is enhanced if unused inputs are tied to an appropriate logic voltage level (for instance, either V_{SS} or V_{DD}) or the programmable pullup resistor associated with the pin is enabled.

Table 12. Absolute Maximum Ratings

($V_{SS} = 0\text{ V}$, $V_{SSA} = 0\text{ V}$)

Characteristic	Symbol	Notes	Min	Max	Unit
Supply Voltage Range	V_{DD}		-0.3	3.8	V
Analog Supply Voltage Range	V_{DDA}		-0.3	3.6	V
Voltage difference V_{DD} to V_{DDA}	ΔV_{DD}		-0.3	0.3	V
Voltage difference V_{SS} to V_{SSA}	ΔV_{SS}		-0.3	0.3	V
Digital Input Voltage Range	V_{IN}	Pin Groups 1, 2	-0.3	$V_{DD}+0.3$	V
Oscillator Voltage Range	V_{OSC}	Pin Group 4	TBD	TBD	V
Analog Input Voltage Range	V_{INA}	Pin Group 3	-0.3	3.6	V
Input clamp current, per pin ($V_{IN} < 0$) ^{1 2 3}	V_{IC}		—	-25.0	mA
Output clamp current, per pin ($V_O < 0$) ^{1 2 3}	V_{OC}		—	-20.0	mA
Output Voltage Range (Normal Push-Pull mode)	V_{OUT}	Pin Group 1	-0.3	V_{DD}	V
Output Voltage Range (Open Drain mode)	V_{OUTOD}	Pin Group 2	-0.3	V_{DD}	V
Ambient Temperature Industrial	T_A		-40	105	°C
Storage Temperature Range (Extended Industrial)	T_{STG}		-55	150	°C

¹ Input must be current limited to the value specified. To determine the value of the required current-limiting resistor, calculate resistance values for positive (V_{DD}) and negative (V_{SS}) clamp voltages, then use the larger of the two resistance values.

² All functional non-supply pins are internally clamped to V_{SS} and V_{DD} .

³ Power supply must maintain regulation within operating V_{DD} range during instantaneous and operating maximum current conditions. If positive injection current ($V_{IN} > V_{DD}$) is greater than I_{DD} , the injection current may flow out of V_{DD} and could result in external power supply going out of regulation. Ensure external V_{DD} loads shunt current greater than maximum injection current. This is the greatest risk when the MCU is not consuming power. Examples are: if no system clock is present or if the clock rate is low (which would reduce overall power consumption).

8.2.1 ESD Protection and Latch-Up Immunity

Although damage from electrostatic discharge (ESD) is much less common on these devices than on early CMOS circuits, use normal handling precautions to avoid exposure to static discharge. Qualification tests are performed to ensure that these devices can withstand exposure to reasonable levels of static without suffering any permanent damage.

Specifications

All ESD testing is in conformity with AEC-Q100 Stress Test Qualification for Automotive Grade Integrated Circuits. During the device qualification ESD stresses were performed for the human body model (HBM), the machine model (MM), and the charge device model (CDM).

A device is defined as a failure if after exposure to ESD pulses the device no longer meets the device specification. Complete DC parametric and functional testing is performed per the applicable device specification at room temperature followed by hot temperature, unless specified otherwise in the device specification.

Table 13. ESD and Latch-up Test Conditions

Model	Description	Symbol	Value	Unit
Human Body	Series Resistance	R1	1500	Ω
	Storage Capacitance	C	100	pF
	Number of Pulses per Pin	—	3	
Machine	Series Resistance	R1	0	Ω
	Storage Capacitance	C	200	pF
	Number of Pulses per Pin	—	3	
Latch-up	Minimum Input Voltage Limit		-2.5	V
	Maximum Input Voltage Limit		7.5	V

Table 14. 56F8006/56F8002 ESD Protection

Characteristic ¹	Min	Typ	Max	Unit
ESD for Human Body Model (HBM)	2000	—	—	V
ESD for Machine Model (MM)	200	—	—	V
ESD for Charge Device Model (CDM)	750	—	—	V
Latch-up current at $T_A = 85^\circ\text{C}$ (I_{LAT})	± 100			mA

¹ Parameter is achieved by design characterization on a small sample size from typical devices under typical conditions unless otherwise noted.

8.3 Thermal Characteristics

This section provides information about operating temperature range, power dissipation, and package thermal resistance. Power dissipation on I/O pins is usually small compared to the power dissipation in on-chip logic and voltage regulator circuits, and it is user-determined rather than being controlled by the MCU design. To take $P_{I/O}$ into account in power calculations, determine the difference between actual pin voltage and V_{SS} or V_{DD} and multiply by the pin current for each I/O pin. Except in cases of unusually high pin current (heavy loads), the difference between pin voltage and V_{SS} or V_{DD} will be very small.

Table 15. 28SOIC Package Thermal Characteristics

Characteristic	Comments	Symbol	Value (LQFP)	Unit
Junction to ambient Natural convection	Single layer board (1s)	$R_{\theta JA}$	70	°C/W
Junction to ambient Natural convection	Four layer board (2s2p)	$R_{\theta JMA}$	47	°C/W
Junction to ambient (@200 ft/min)	Single layer board (1s)	$R_{\theta JMA}$	55	°C/W
Junction to ambient (@200 ft/min)	Four layer board (2s2p)	$R_{\theta JMA}$	42	°C/W
Junction to board		$R_{\theta JB}$	23	°C/W
Junction to case		$R_{\theta JC}$	26	°C/W
Junction to package top	Natural Convection	Ψ_{JT}	9	°C/W

Table 16. 32LQFP Package Thermal Characteristics

Characteristic	Comments	Symbol	Value (LQFP)	Unit
Junction to ambient Natural convection	Single layer board (1s)	$R_{\theta JA}$	84	°C/W
Junction to ambient Natural convection	Four layer board (2s2p)	$R_{\theta JMA}$	56	°C/W
Junction to ambient (@200 ft/min)	Single layer board (1s)	$R_{\theta JMA}$	70	°C/W
Junction to ambient (@200 ft/min)	Four layer board (2s2p)	$R_{\theta JMA}$	49	°C/W
Junction to board		$R_{\theta JB}$	33	°C/W
Junction to case		$R_{\theta JC}$	20	°C/W
Junction to package top	Natural Convection	Ψ_{JT}	4	°C/W

Table 17. 48LQFP Package Thermal Characteristics

Characteristic	Comments	Symbol	Value (LQFP)	Unit
Junction to ambient Natural convection	Single layer board (1s)	$R_{\theta JA}$	79	°C/W
Junction to ambient Natural convection	Four layer board (2s2p)	$R_{\theta JMA}$	55	°C/W
Junction to ambient (@200 ft/min)	Single layer board (1s)	$R_{\theta JMA}$	66	°C/W

Table 17. 48LQFP Package Thermal Characteristics

Characteristic	Comments	Symbol	Value (LQFP)	Unit
Junction to ambient (@200 ft/min)	Four layer board (2s2p)	$R_{\theta JMA}$	48	°C/W
Junction to board		$R_{\theta JB}$	34	°C/W
Junction to case		$R_{\theta JC}$	20	°C/W
Junction to package top	Natural Convection	Ψ_{JT}	4	°C/W

NOTE

Junction-to-ambient thermal resistance determined per JEDEC JESD51–3 and JESD51–6. Thermal test board meets JEDEC specification for this package.

Junction-to-board thermal resistance determined per JEDEC JESD51–8. Thermal test board meets JEDEC specification for the specified package.

Junction-to-case at the top of the package determined using MIL-STD 883 Method 1012.1. The cold plate temperature is used for the case temperature. Reported value includes the thermal resistance of the interface layer.

Thermal characterization parameter indicating the temperature difference between the package top and the junction temperature per JEDEC JESD51–2. When Greek letters are not available, the thermal characterization parameter is written as Psi-JT

Junction temperature is a function of die size, on-chip power dissipation, package thermal resistance, mounting site (board) temperature, ambient temperature, air flow, power dissipation of other components on the board, and board thermal resistance.

See [Section 9.1, “Thermal Design Considerations,”](#) for more detail on thermal design considerations.

8.4 Recommended Operating Conditions

This section includes information about recommended operating conditions.

Table 18. Recommended Operating Conditions

($V_{REFLX} = 0\text{ V}$, $V_{SSA} = 0\text{ V}$, $V_{SS} = 0\text{ V}$)

Characteristic	Symbol	Notes	Min	Typ	Max	Unit
Supply voltage	V_{DD}, V_{DDA}		3	3.3	3.6	V
Voltage difference V_{DD} to V_{DDA}	ΔV_{DD}		–0.1	0	0.1	V
Voltage difference V_{SS} to V_{SSA}	ΔV_{SS}		–0.1	0	0.1	V
Device Clock Frequency Using relaxation oscillator Using external clock source	FSYSCLK		1 0		32 32	MHz
Input Voltage High (digital inputs)	V_{IH}	Pin Groups 1, 2	2.0		V_{DD}	V
Input Voltage Low (digital inputs)	V_{IL}	Pin Groups 1, 2	–0.3		0.8	V
Oscillator Input Voltage High XTAL driven by an external clock source	V_{IHOSC}	Pin Group 4	2.0		$V_{DDA} + 0.3$	V
Oscillator Input Voltage Low	V_{ILOSC}	Pin Group 4	–0.3		0.8	V

Table 18. Recommended Operating Conditions $(V_{REFLx} = 0\text{ V}, V_{SSA} = 0\text{ V}, V_{SS} = 0\text{ V})$

Characteristic	Symbol	Notes	Min	Typ	Max	Unit
Output Source Current High at V_{OH} min.) ¹ When programmed for low drive strength When programmed for high drive strength	I_{OH}	Pin Group 1 Pin Group 1	— —		-4 -8	mA
Output Source Current Low (at V_{OL} max.) ¹ When programmed for low drive strength When programmed for high drive strength	I_{OL}	Pin Groups 1, 2 Pin Groups 1, 2	— —		4 8	mA
Ambient Operating Temperature (Extended Industrial)	T_A		-40		105	°C
Flash Endurance (Program Erase Cycles)	N_F	$T_A = -40^\circ\text{C}$ to 125°C	10,000		—	cycles
Flash Data Retention	t_R	$T_J \leq 85^\circ\text{C}$ avg	15		—	years
Flash Data Retention with <100 Program/Erase Cycles	t_{FLRET}	$T_J \leq 85^\circ\text{C}$ avg	20	—	—	years

¹ Total chip source or sink current cannot exceed 75 mA.**Table 19. Default Mode**

Pin Group 1	GPIO, TDI, TDO, TMS, TCK
Pin Group 2	SCL, SDA
Pin Group 3	ADC and Comparator Analog Inputs and PGA Inputs
Pin Group 4	XTAL, EXTAL

8.5 DC Electrical Characteristics

This section includes information about power supply requirements and I/O pin characteristics.

Table 20. DC Characteristics

Characteristic	Symbol	Condition	Min	Typ ¹	Max	Unit
Operating Voltage			1.8 ²		3.6	V
Output high voltage	V_{OH}	All I/O pins, low-drive strength $1.8\text{ V}, I_{Load} = -2\text{ mA}$	$V_{DD} - 0.5$	—	—	V
		All I/O pins, high-drive strength $2.7\text{ V}, I_{Load} = -10\text{ mA}$	$V_{DD} - 0.5$	—	—	
		$2.3\text{ V}, I_{Load} = -6\text{ mA}$	$V_{DD} - 0.5$	—	—	
		$1.8\text{ V}, I_{Load} = -3\text{ mA}$	$V_{DD} - 0.5$	—	—	
Output high current	I_{OHT}	Max total I_{OH} for all ports	—	—	100	mA

Table 20. DC Characteristics

Characteristic	Symbol	Condition	Min	Typ ¹	Max	Unit
Output low voltage All I/O pins, low-drive strength All I/O pins, high-drive strength	V _{OL}	1.8 V, I _{Load} = 2 mA	—	—	0.5	V
		2.7 V, I _{Load} = 10 mA	—	—	0.5	
		2.3 V, I _{Load} = 6 mA	—	—	0.5	
		1.8 V, I _{Load} = 3 mA	—	—	0.5	
Output low current Max total I _{OL} for all ports	I _{OLT}		—	—	100	mA
Input high voltage all digital inputs	V _{IH}	V _{DD} > 2.7 V	0.70 x V _{DD}	—	—	V
		V _{DD} > 1.8 V	0.85 x V _{DD}	—	—	
Input low voltage all digital inputs	V _{IL}	V _{DD} > 2.7 V	—	—	0.35 x V _{DD}	
		V _{DD} > 1.8 V	—	—	0.30 x V _{DD}	
Input hysteresis all digital inputs	V _{hys}		0.06 x V _{DD}	—	—	mV
Input leakage current all input only pins (Per pin)	I _{IinI}	V _{In} = V _{DD} or V _{SS}	—	—	1	μA
Hi-Z (off-state) leakage current all input/output (per pin)	I _{IozI}	V _{In} = V _{DD} or V _{SS}	—	—	1	μA
Pullup resistors all digital inputs, when enabled	R _{PU}		17.5	—	52.5	kΩ
DC injection current ^{3, 4, 5} Single pin limit Total MCU limit, includes sum of all stressed pins	I _{IC}	V _{In} < V _{SS} , V _{In} > V _{DD}	-0.2	—	0.2	mA
			-5	—	5	mA
Input Capacitance, all pins	C _{In}		—	—	8	pF
RAM retention voltage	V _{RAM}		—	0.6	1.0	V
POR re-arm voltage ⁶	V _{POR}		0.9	1.4	1.79	V
POR re-arm time	t _{POR}		10	—	—	μs
Low-voltage detection threshold — high range ⁷	V _{LVDH} ⁸	V _{DD} falling	2.31	2.34	2.36	V
		V _{DD} rising	2.40	2.44	2.45	
Low-voltage detection threshold — low range ⁷	V _{LVDL}	V _{DD} falling	1.81	1.84	1.86	V
		V _{DD} rising	1.91	1.93	1.95	
Low-voltage warning threshold	V _{LVW}	V _{DD} falling	2.58	2.63	2.66	V
		V _{DD} rising	2.65	2.69	2.71	
Low-voltage inhibit reset/recover hysteresis ⁷	V _{hys}		—	50	—	mV
Bandgap Voltage Reference ⁹	V _{BG}		1.15	1.17	1.18	V

¹ Typical values are measured at 25°C. Characterized, not tested

² As the supply voltage rises, the LVD circuit holds the MCU in reset until the supply has risen above V_{LVDL}.

³ All functional non-supply pins are internally clamped to V_{SS} and V_{DD}.

⁴ Input must be current limited to the value specified. To determine the value of the required current-limiting resistor, calculate resistance values for positive and negative clamp voltages, then use the larger of the two values.

- 5 Power supply must maintain regulation within operating V_{DD} range during instantaneous and operating maximum current conditions. If positive injection current ($V_{in} > V_{DD}$) is greater than I_{DD} , the injection current may flow out of V_{DD} and could result in external power supply going out of regulation. Ensure external V_{DD} load shunts current greater than maximum injection current. This is the greatest risk when the MCU is not consuming power. Examples are: if no system clock is present or if clock rate is low (which would reduce overall power consumption).
- 6 Maximum is highest voltage that POR is guaranteed.
- 7 Low voltage detection and warning limits measured at 32 MHz bus frequency.
- 8 Runs at 32 MHz bus frequency.
- 9 Factory trimmed at $V_{DD} = 3.3$ V, Temp = 25°C

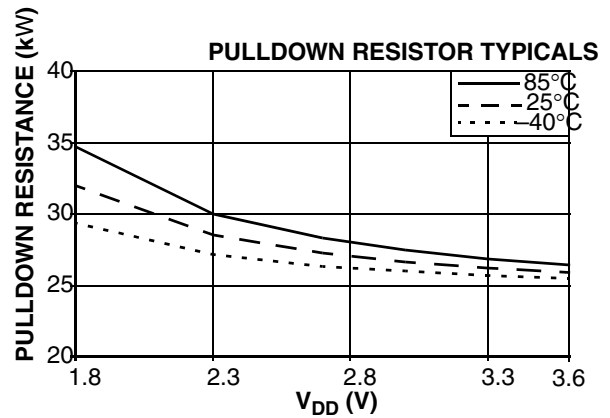
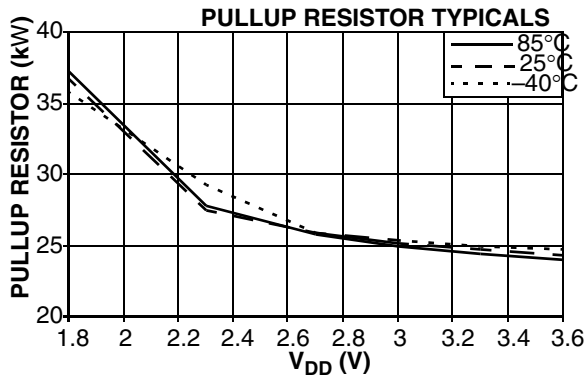

Figure 15. Pullup and Pulldown Typical Resistor Values

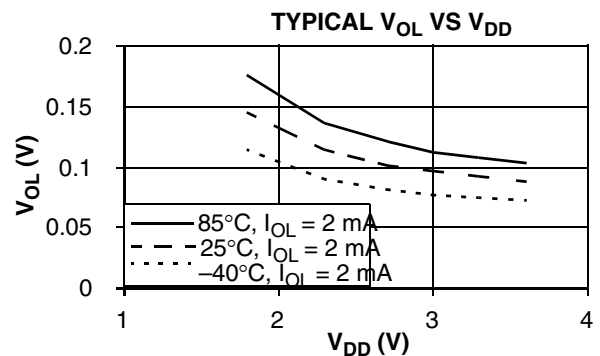
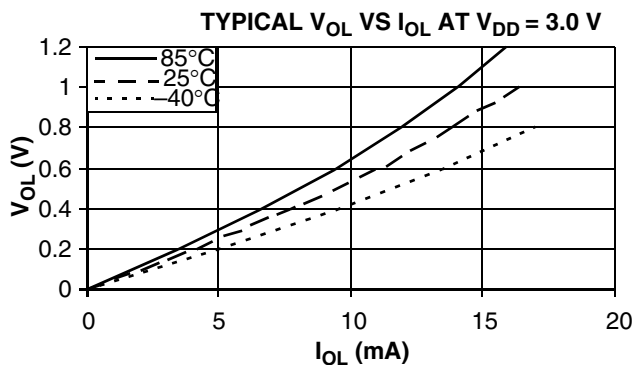

Figure 16. Typical Low-Side Driver (Sink) Characteristics — Low Drive ($GPIO_x_DRIVE_n = 0$)

Specifications

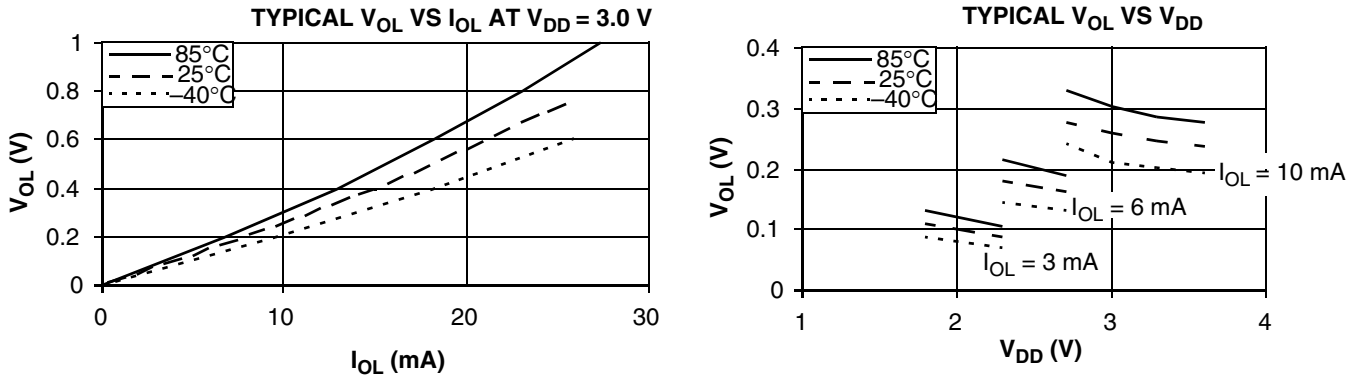

Figure 17. Typical Low-Side Driver (Sink) Characteristics — High Drive (GPIO_x_DRIVEN = 1)

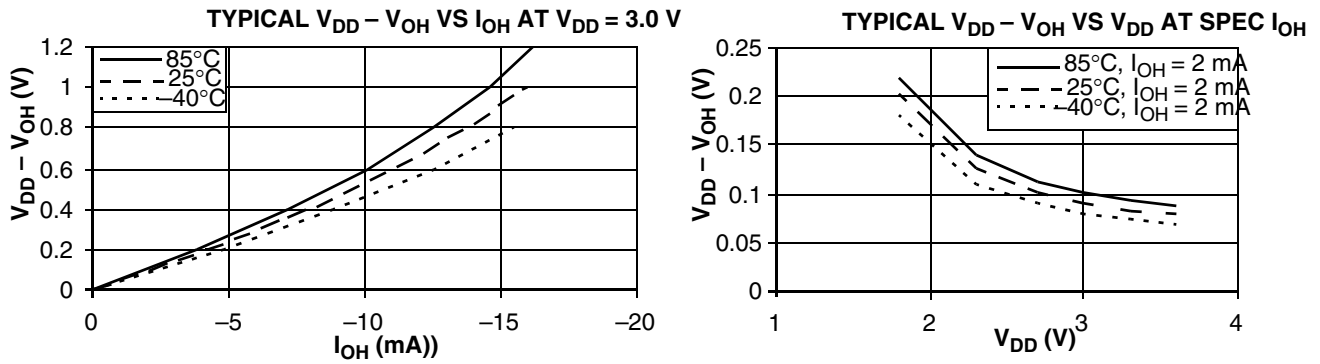

Figure 18. Typical High-Side (Source) Characteristics — Low Drive (GPIO_x_DRIVEN = 0)

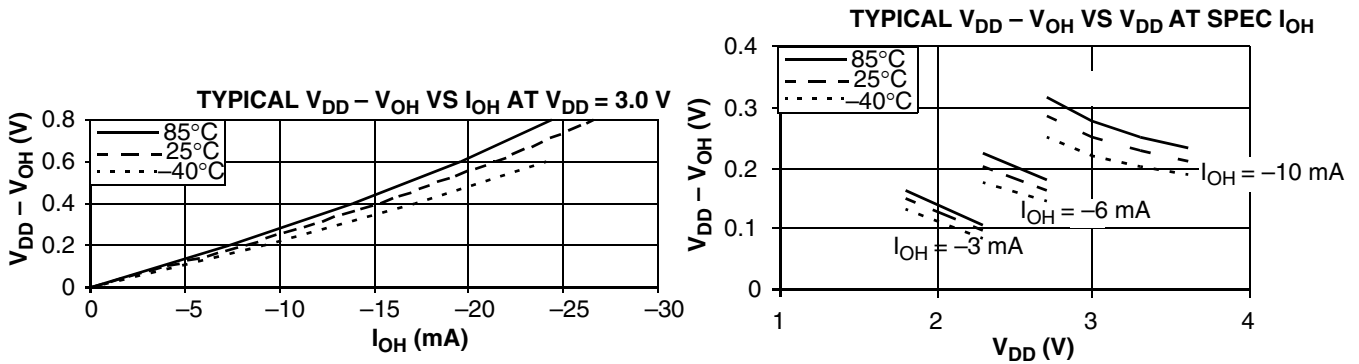

Figure 19. Typical High-Side (Source) Characteristics — High Drive (GPIO_x_DRIVEN = 1)

8.6 Supply Current Characteristics

Table 21. Supply Current Consumption

Mode	Conditions	Typical @ 3.3 V, 25°C		Maximum @ 3.6 V, 25°C	
		I _{DD} ¹	I _{DDA}	I _{DD} ¹	I _{DDA}
Run	32 MHz device clock; relaxation oscillator (ROSC) in high speed mode; PLL engaged; All peripheral modules enabled. TMR and PWM using 1X clock; continuous MAC instructions with fetches from program flash; ADC/DAC powered on and clocked; comparator powered on.	45.6 mA	4.55 mA	TBD	TBD
LSrun ²	200 kHz device clock; relaxation oscillator (ROSC) in standby mode; PLL disabled All peripheral modules disabled and clock gated off; simple loop with fetches from program flash;	573.06 μA	573.06 μA	—	—
LPrun ³	32.768 kHz device clock; Clocked by a 32.768 kHz external crystal relaxation oscillator (ROSC) in power down; PLL disabled All peripheral modules disabled and clock gated off; simple loop with fetches from program flash;	TBD	TBD	—	—
Wait	32 MHz device clock relaxation oscillator (ROSC) in high speed mode PLL engaged; All non-communication peripherals enabled and running; all communication peripherals disabled but clocked; processor core in wait state	19.94 mA	19.94 mA	—	—
LSwait ²	200 kHz device clock; relaxation oscillator (ROSC) in standby mode; PLL disabled; All peripheral modules disabled and clock gated off; processor core in wait state	495.2 μA	81.99 μA	—	—
LPwait ³	32.768 kHz device clock; Clocked by a 32.768 kHz external crystal relaxation oscillator (ROSC) in power down; PLL disabled; All peripheral modules disabled and clock gated off; processor core in wait state	TBD	TBD	—	—
Stop	32 MHz device clock relaxation oscillator (ROSC) in high speed mode; PLL engaged; all peripheral module and core clocks are off; ADC/DAC/comparator powered off; processor core in stop state	6.38 mA	2.89 mA	—	—

Table 21. Supply Current Consumption

Mode	Conditions	Typical @ 3.3 V, 25°C		Maximum @ 3.6 V, 25°C	
		I _{DD} ¹	I _{DDA}	I _{DD} ¹	I _{DDA}
LSstop ²	200 kHz device clock; relaxation oscillator (ROSC) in standby mode; PLL disabled; all peripheral modules disabled and clock gated off; processor core in stop state.	36.72 μA	82.03 μA	—	—
LPstop ²	32.768 kHz device clock; Clocked by a 32.768 kHz external crystal relaxation oscillator (ROSC) in power down; PLL disabled; all peripheral modules disabled and clock gated off; processor core in stop state.	TBD	TBD	—	—
PPD ⁴ with XOSC	32.768 kHz clock fed on XTAL RTC or COP monitoring XOSC (but no wakeup) processor core in stop state	140.14 μA	0.5 μA	—	—
PPD with LP oscillator (1 kHz) enabled	RTC or COP monitoring LP oscillator (but no wakeup); processor core in stop state.	3.39 μA	2.45 μA	—	—
PPD with no clock monitoring	RTC and LP oscillator are disabled; processor core in stop state.	3.57 μA	2.66 μA	—	—

¹ No output switching; all ports configured as inputs; all inputs low; no DC loads.

² Low speed mode: LPR (lower voltage regulator control bit) = 0 and voltage regulator is in full regulation. Characterization only.

³ Low power mode: LPR (lower voltage regulator control bit) = 1; the voltage regulator is put into standby.

⁴ Partial power down mode: PPDE (partial power down enable bit) = 1; power management controller (PMC) enters partial power down mode the next time that the STOP command is executed.

8.7 Flash Memory Characteristics

Table 22. Flash Timing Parameters

Characteristic	Symbol	Min	Typ	Max	Unit
Program time ¹	t _{prog}	20	—	40	μs
Erase time ²	t _{erase}	20	—	—	ms
Mass erase time	t _{me}	100	—	—	ms

¹ There is additional overhead that is part of the programming sequence. See the *MC56F8006 Peripheral Reference Manual* for detail.

² Specifies page erase time. There are 512 bytes per page in the program flash memory.

8.8 External Clock Operation Timing

Table 23. External Clock Operation Timing Requirements¹

Characteristic	Symbol	Min	Typ	Max	Unit
Frequency of operation (external clock driver) ²	f_{osc}	—	—	64	MHz
Clock pulse width ³	t_{PW}	6.25	—	—	ns
External clock input rise time ⁴	t_{rise}	—	—	3	ns
External clock input fall time ⁵	t_{fall}	—	—	3	ns
Input high voltage overdrive by an external clock	V_{ih}	$0.85V_{DD}$	—	—	V
Input high voltage overdrive by an external clock	V_{il}	—	—	$0.3V_{DD}$	V

¹ Parameters listed are guaranteed by design.

² See Figure 20 for detail on using the recommended connection of an external clock driver.

³ The chip may not function if the high or low pulse width is smaller than 6.25 ns.

⁴ External clock input rise time is measured from 10% to 90%.

⁵ External clock input fall time is measured from 90% to 10%.

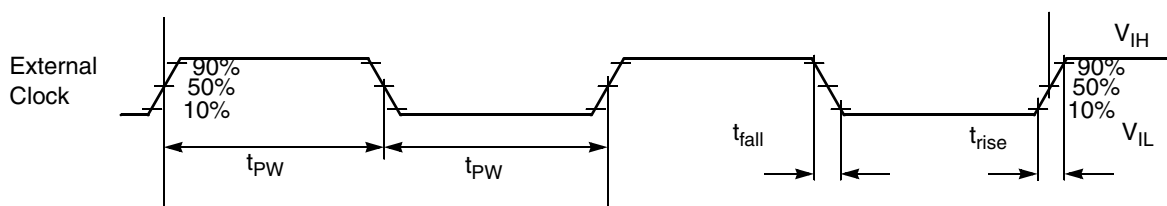

Note: The midpoint is $V_{IL} + (V_{IH} - V_{IL})/2$.

Figure 20. External Clock Timing

8.9 Phase Locked Loop Timing

Table 24. Phase Locked Loop Timing

Characteristic	Symbol	Min	Typ	Max	Unit
PLL input reference frequency ¹	f_{ref}	4	8	—	MHz
PLL output frequency ²	f_{op}	120	192	—	MHz
PLL lock time ^{3 4}	t_{pills}	—	40	100	μs
Accumulated jitter using an 8 MHz external crystal as the PLL source ⁵	J_A	—	—	0.37	%
Cycle-to-cycle jitter	$t_{jitterpll}$	—	350	—	ps

¹ An externally supplied reference clock should be as free as possible from any phase jitter for the PLL to work correctly. The PLL is optimized for 8 MHz input.

² The core system clock operates at 1/6 of the PLL output frequency.

³ This is the time required after the PLL is enabled to ensure reliable operation.

⁴ From powerdown to powerup state at 32 MHz system clock state.

⁵ This is measured on the CLK0 signal (programmed as system clock) over 264 system clocks at 32 MHz system clock frequency and using an 8 MHz oscillator frequency.

8.10 Relaxation Oscillator Timing

Table 25. Relaxation Oscillator Timing

Characteristic	Symbol	Minimum	Typical	Maximum	Unit
Relaxation oscillator output frequency ¹ Normal Mode Standby Mode	f_{op}	—	8.05 400	—	MHz MHz
Relaxation oscillator stabilization time ²	t_{roscs}	—	1	3	ms
Cycle-to-cycle jitter. This is measured on the CLKO signal (programmed prescaler_clock) over 264 clocks ³	$t_{jitterosc}$	—	400	—	ps
Variation over temperature -40°C to 150°C ⁴		—	+1.0 to -1.5	+3.0 to -3.0	%
Variation over temperature 0°C to 105°C ⁴		—	0 to +1	+2.0 to -2.0	%

¹ Output frequency after factory trim.

² This is the time required from standby to normal mode transition.

³ J_A is required to meet QSCI requirements.

⁴ See [Figure 21](#).

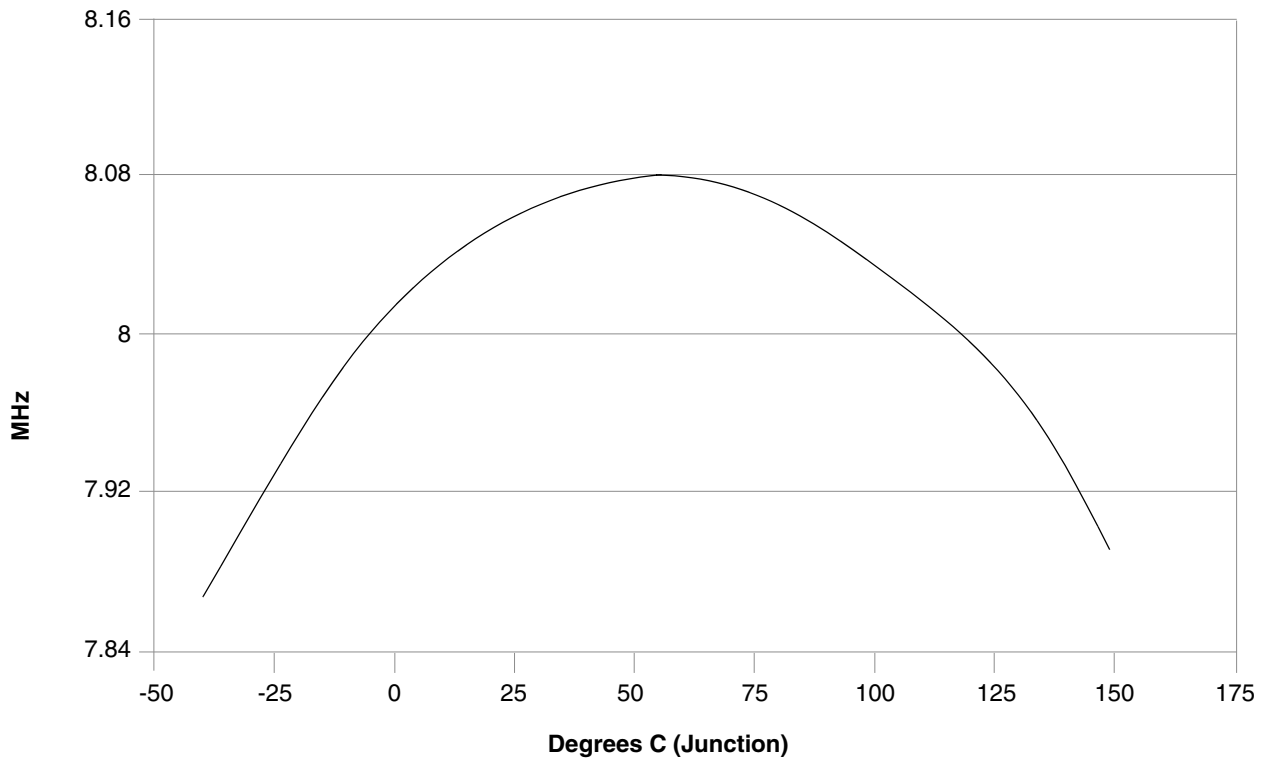

Figure 21. Relaxation Oscillator Temperature Variation (Typical) After Trim

8.11 Reset, Stop, Wait, Mode Select, and Interrupt Timing

NOTE

All address and data buses described here are internal.

Table 26. Reset, Stop, Wait, Mode Select, and Interrupt Timing^{1,2}

Characteristic	Symbol	Typical Min	Typical Max	Unit	See Figure
Minimum $\overline{\text{RESET}}$ Assertion Duration	t_{RA}	4T	—	ns	—
Minimum GPIO pin Assertion for Interrupt	t_{IW}	2T	—	ns	Figure 22
$\overline{\text{RESET}}$ deassertion to First Address Fetch	t_{RDA}	$96T_{\text{OSC}} + 64T$	$97T_{\text{OSC}} + 65T$	ns	—
Delay from Interrupt Assertion to Fetch of first instruction (exiting Stop)	t_{IF}	—	6T	ns	—

¹ In the formulas, T = system clock cycle and T_{OSC} = oscillator clock cycle. For an operating frequency of 32 MHz, T = 31.25 ns. At 4 MHz (used coming out of reset and stop modes), T = 250 ns.

² Parameters listed are guaranteed by design.

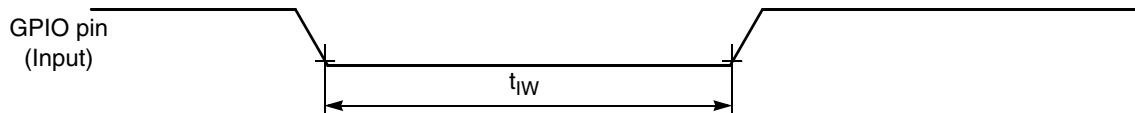

Figure 22. GPIO Interrupt Timing (Negative Edge-Sensitive)

8.12 External Oscillator (XOSC) Characteristics

Reference [Figure 9](#), and [Figure 10](#), and [Figure 11](#) for crystal or resonator circuits.

Table 27. Crystal Oscillator Characteristics

Characteristic	Symbol	Min	Typ ¹	Max	Unit
Oscillator crystal or resonator (PRECS = 1, CLK_MOD = 0)					
Low range (RANGE = 0)	f_{lo}	32	—	38.4	MHz
High range (RANGE = 1), high gain (COHL =0)	f_{hi}	1	—	16	MHz
High range (RANGE = 1), low power (COHL =1)	f_{hi}	1	—	8	MHz
Load capacitors	C_1, C_2	See Note ² See Note ³			
Feedback resistor	R_F				$M\Omega$
Low range, low power (RANGE=0, COHL =1) ²		—	—	—	
Low range, high gain (RANGE=0, COHL =0)		—	10	—	
High range (RANGE=1, COHL=X)		—	1	—	
Series resistor	R_S				$k\Omega$
Low range, low power (RANGE = 0, COHL =1) ²		—	0	—	
Low range, high gain (RANGE = 0, COHL =0)		—	100	—	
High range, low power (RANGE = 1, COHL =1)		—	0	—	
High range, high gain (RANGE = 1,COHL =0)					
≥ 8 MHz		—	0	0	
4 MHz		—	0	10	
1 MHz		—	0	20	
Crystal start-up time ⁴					
Low range, low power	t_{CSTL}	—	TBD	—	ms
Low range, high gain		—	TBD	—	
High range, low power	t_{CSTH}	—	TBD	—	
High range, high gain		—	TBD	—	
Square wave input clock frequency (PRECS = 1, CLK_MOD = 1)	f_{xtal}	—	—	50.0	MHz

¹ Data in Typical column was characterized at 3.0 V, 25°C or is typical recommended value.
² Load capacitors (C_1, C_2), feedback resistor (R_F) and series resistor (R_S) are incorporated internally when RANGE=HGO=0.
³ See crystal or resonator manufacturer’s recommendation.
⁴ Proper PC board layout procedures must be followed to achieve specifications.

8.13 AC Electrical Characteristics

Tests are conducted using the input levels specified in Table 21. Unless otherwise specified, propagation delays are measured from the 50% to the 50% point, and rise and fall times are measured between the 10% and 90% points, as shown in Figure 23.

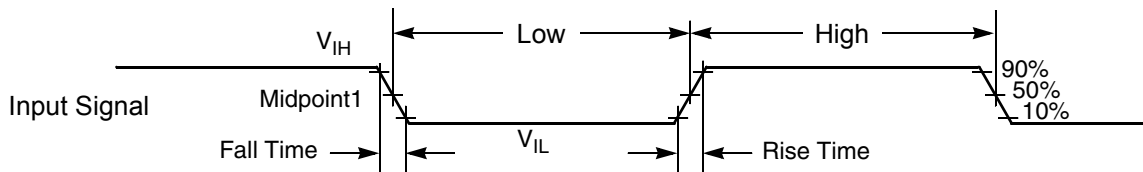

The midpoint is $V_{IL} + (V_{IH} - V_{IL})/2$.

Figure 23. Input Signal Measurement References

Figure 24 shows the definitions of the following signal states:

- Active state, when a bus or signal is driven, and enters a low impedance state

- Tri-stated, when a bus or signal is placed in a high impedance state
- Data Valid state, when a signal level has reached V_{OL} or V_{OH}
- Data Invalid state, when a signal level is in transition between V_{OL} and V_{OH}

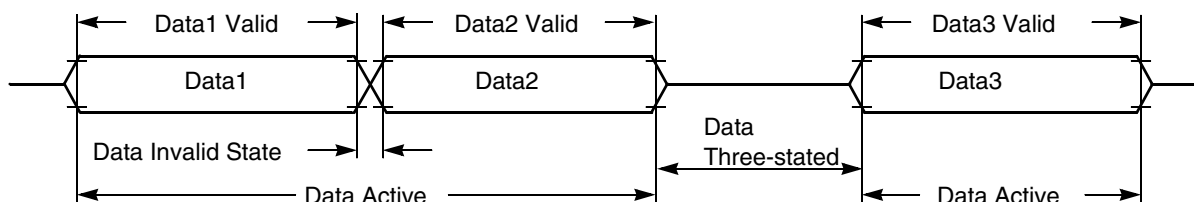

Figure 24. Signal States

8.13.1 Serial Peripheral Interface (SPI) Timing

Table 28. SPI Timing¹

Characteristic	Symbol	Min	Max	Unit	See Figure
Cycle time Master Slave	t_C	125 62.5	— —	ns ns	Figure 25, Figure 26, Figure 27, Figure 28
Enable lead time Master Slave	t_{ELD}	— 31	— —	ns ns	Figure 28
Enable lag time Master Slave	t_{ELG}	— 125	— —	ns ns	Figure 28
Clock (SCK) high time Master Slave	t_{CH}	50 31	— —	ns ns	Figure 25, Figure 26, Figure 27, Figure 28
Clock (SCK) low time Master Slave	t_{CL}	50 31	— —	ns ns	Figure 28
Data set-up time required for inputs Master Slave	t_{DS}	20 0	— —	ns ns	Figure 25, Figure 26, Figure 27, Figure 28
Data hold time required for inputs Master Slave	t_{DH}	0 2	— —	ns ns	Figure 25, Figure 26, Figure 27, Figure 28
Access time (time to data active from high-impedance state) Slave	t_A	4.8	15	ns	Figure 28
Disable time (hold time to high-impedance state) Slave	t_D	3.7	15.2	ns	Figure 28

Table 28. SPI Timing¹

Characteristic	Symbol	Min	Max	Unit	See Figure
Data valid for outputs Master Slave (after enable edge)	t_{DV}	— —	4.5 20.4	ns ns	Figure 25, Figure 26, Figure 27, Figure 28
Data invalid Master Slave	t_{DI}	0 0	— —	ns ns	Figure 25, Figure 26, Figure 27, Figure 28
Rise time Master Slave	t_R	— —	11.5 10.0	ns ns	Figure 25, Figure 26, Figure 27, Figure 28
Fall time Master Slave	t_F	— —	9.7 9.0	ns ns	Figure 25, Figure 26, Figure 27, Figure 28

¹ Parameters listed are guaranteed by design.

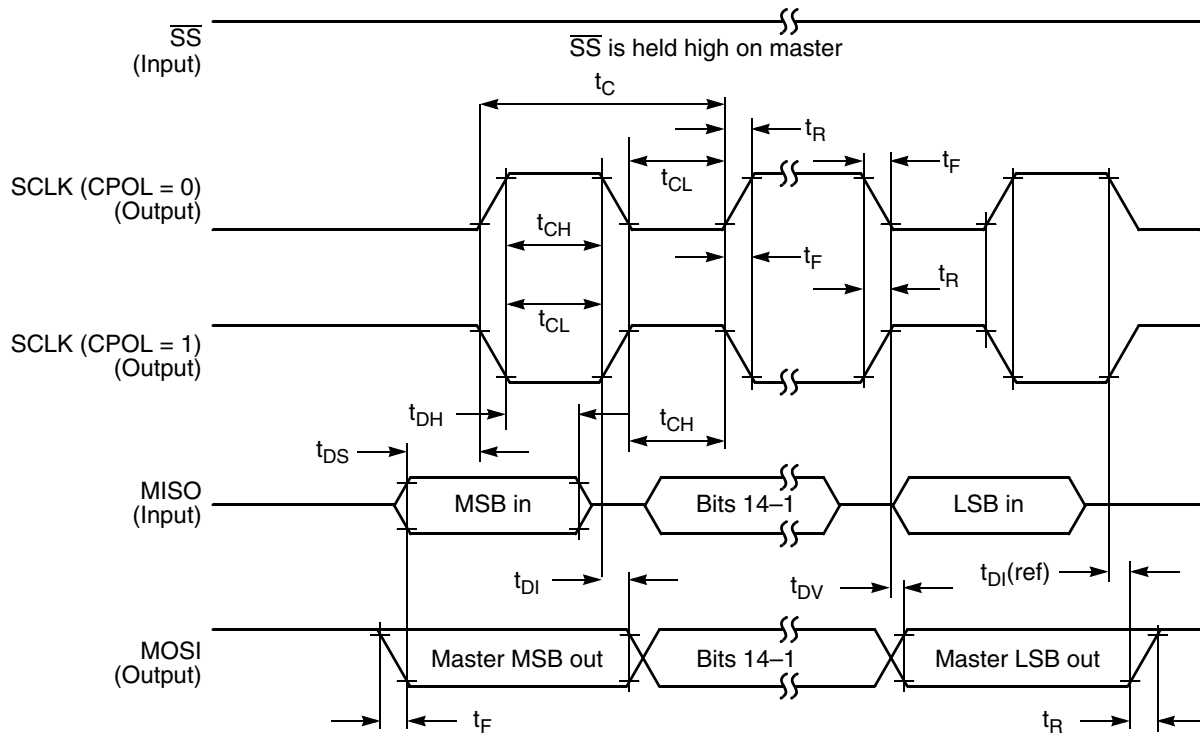

Figure 25. SPI Master Timing (CPHA = 0)

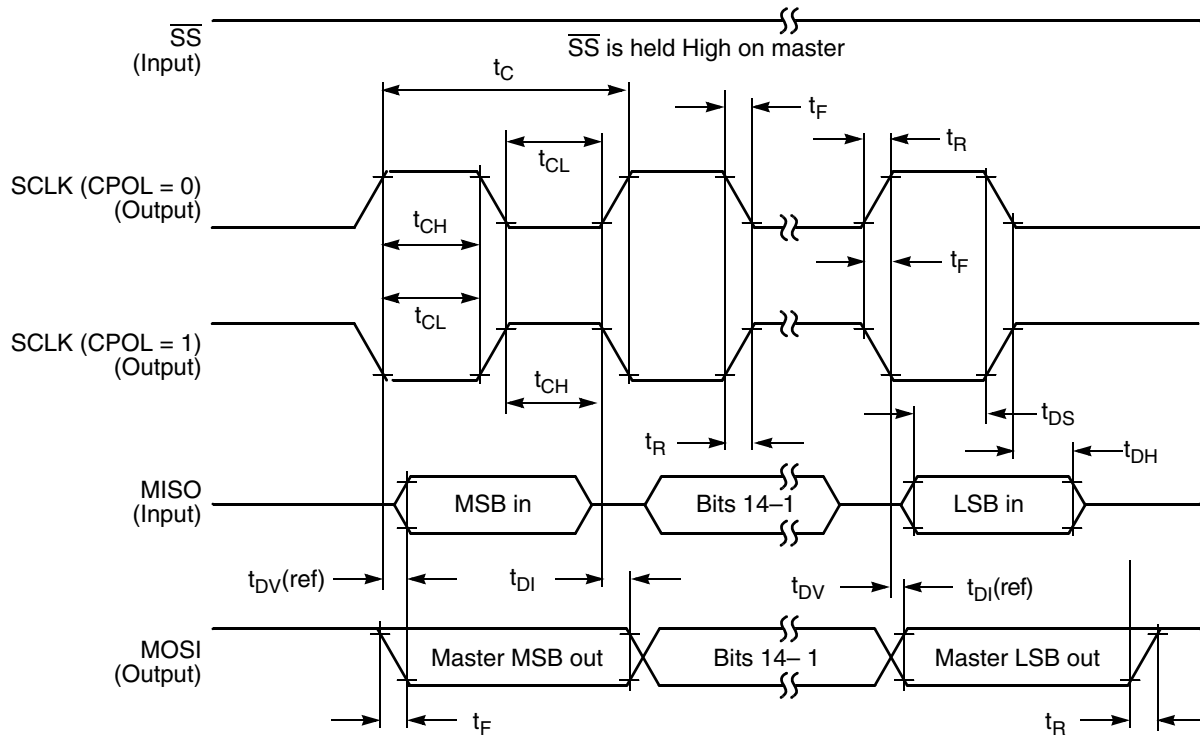

Figure 26. SPI Master Timing (CPHA = 1)

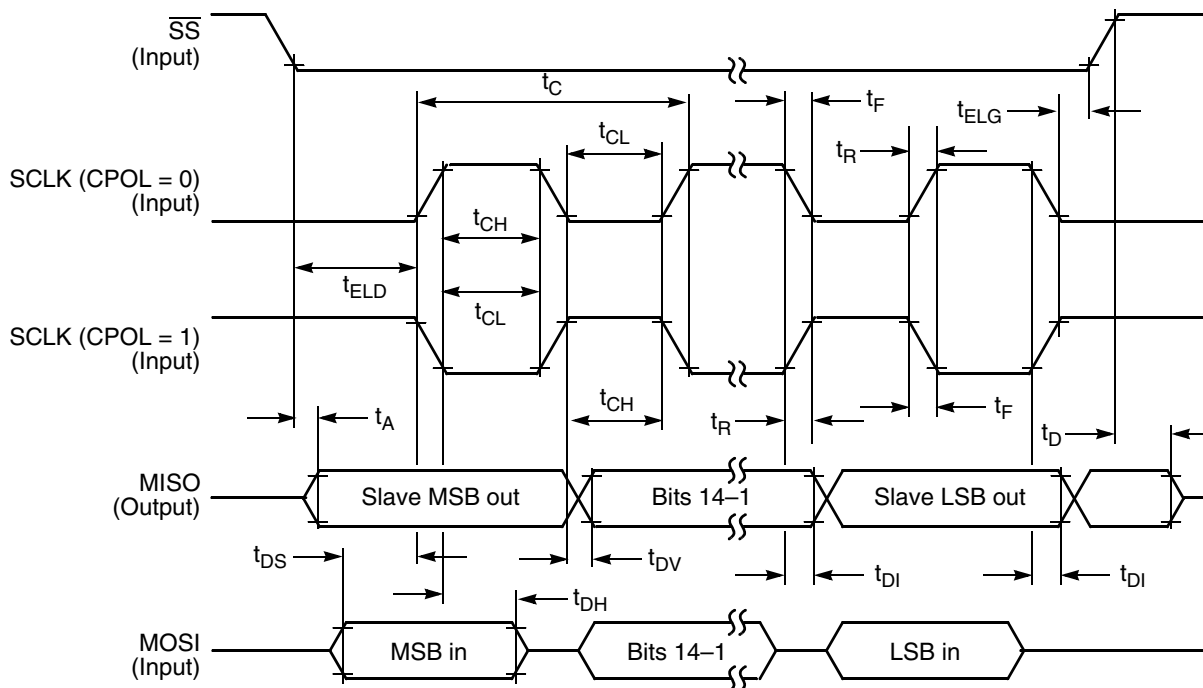

Figure 27. SPI Slave Timing (CPHA = 0)

Specifications

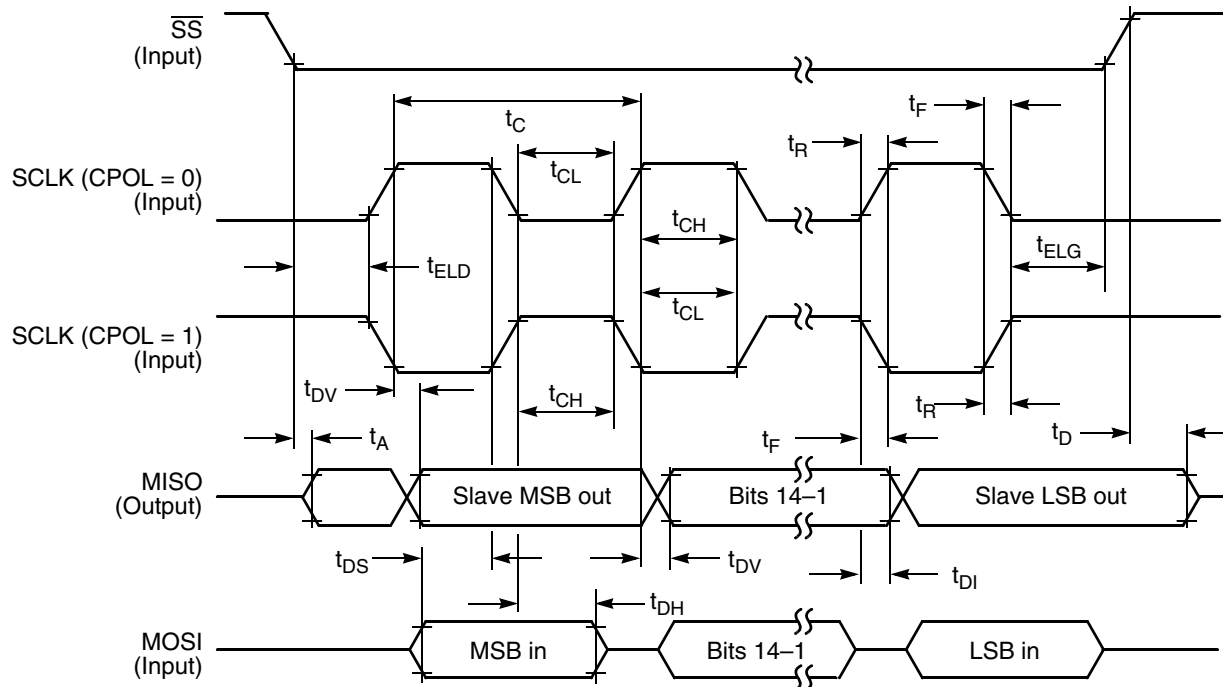

Figure 28. SPI Slave Timing (CPHA = 1)

8.13.2 Serial Communication Interface (SCI) Timing

Table 29. SCI Timing¹

Characteristic	Symbol	Min	Max	Unit	See Figure
Baud rate ²	BR	—	($f_{MAX}/16$)	Mbps	—
RXD pulse width	RXD _{PW}	0.965/BR	1.04/BR	ns	Figure 29
TXD pulse width	TXD _{PW}	0.965/BR	1.04/BR	ns	Figure 30
LIN Slave Mode					
Deviation of slave node clock from nominal clock rate before synchronization	F _{TOL_UNSYNCH}	-14	14	%	—
Deviation of slave node clock relative to the master node clock after synchronization	F _{TOL_SYNCH}	-2	2	%	—
Minimum break character length	T _{BREAK}	13	—	Master node bit periods	—
		11	—	Slave node bit periods	—

¹ Parameters listed are guaranteed by design.

² f_{MAX} is the frequency of operation of the SCI in MHz, which can be selected system clock (max. 32 MHz) or 3x system clock (max. 96 MHz) for the 56F8006/56F8002 device.

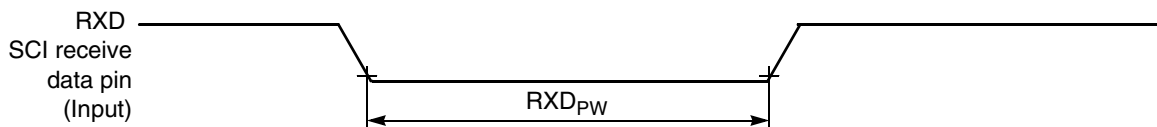

Figure 29. RXD Pulse Width

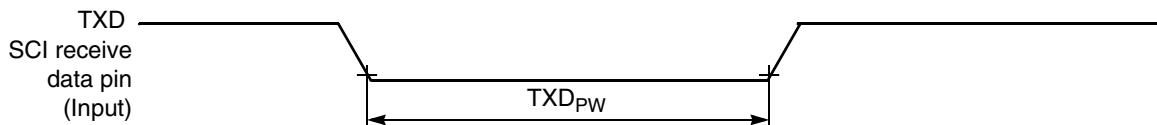

Figure 30. TXD Pulse Width

8.13.3 Inter-Integrated Circuit Interface (I²C) Timing

Table 30. I²C Timing

Characteristic	Symbol	Standard Mode		Fast Mode		Unit
		Minimum	Maximum	Minimum	Maximum	
SCL Clock Frequency	f_{SCL}	0	100	0	400	MHz
Hold time (repeated) START condition. After this period, the first clock pulse is generated.	$t_{HD; STA}$	4.0	—	0.6	—	μs
LOW period of the SCL clock	t_{LOW}	4.7	—	1.3	—	μs
HIGH period of the SCL clock	t_{HIGH}	4.0	—	0.6	—	μs
Set-up time for a repeated START condition	$t_{SU; STA}$	4.7	—	0.6	—	μs
Data hold time for I ² C bus devices	$t_{HD; DAT}$	0 ¹	3.45 ²	0 ¹	0.9 ²	μs
Data set-up time	$t_{SU; DAT}$	250 ³	—	100 ^{3, 4}	—	ns
Rise time of SDA and SCL signals	t_r	—	1000	$20 + 0.1C_b^5$	300	ns
Fall time of SDA and SCL signals	t_f	—	300	$20 + 0.1C_b^5$	300	ns
Set-up time for STOP condition	$t_{SU; STO}$	4.0	—	0.6	—	μs
Bus free time between STOP and START condition	t_{BUF}	4.7	—	1.3	—	μs
Pulse width of spikes that must be suppressed by the input filter	t_{SP}	N/A	N/A	0	50	ns

Specifications

- ¹ The master mode I²C deasserts ACK of an address byte simultaneously with the falling edge of SCL. If no slaves acknowledge this address byte, a negative hold time can result, depending on the edge rates of the SDA and SCL lines.
- ² The maximum $t_{HD; DAT}$ must be met only if the device does not stretch the LOW period (t_{LOW}) of the SCL signal.
- ³ Set-up time in slave-transmitter mode is 1 IPBus clock period, if the TX FIFO is empty.
- ⁴ A Fast mode I²C bus device can be used in a Standard mode I²C bus system, but the requirement $t_{SU; DAT} \geq 250$ ns must then be met. This is automatically the case if the device does not stretch the LOW period of the SCL signal. If such a device does stretch the LOW period of the SCL signal, it must output the next data bit to the SDA line $t_{rmax} + t_{SU; DAT} = 1000 + 250 = 1250$ ns (according to the Standard mode I²C bus specification) before the SCL line is released.
- ⁵ C_b = total capacitance of the one bus line in pF.

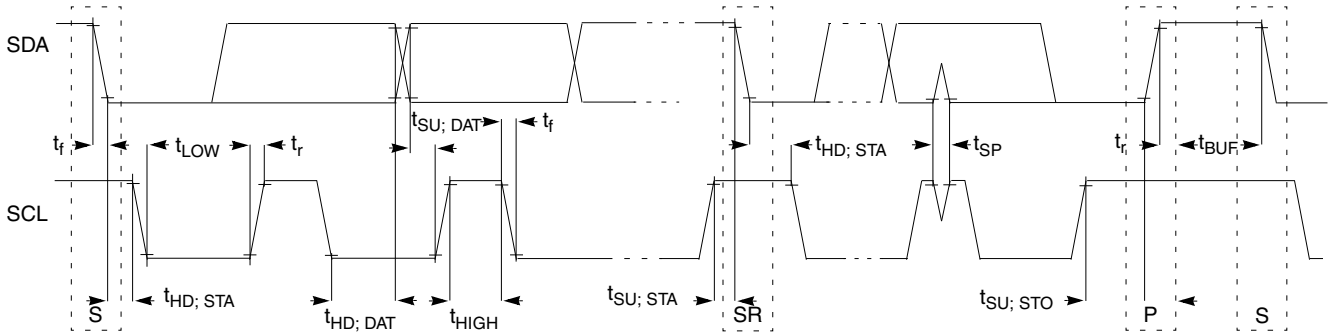

Figure 31. Timing Definition for Fast and Standard Mode Devices on the I²C Bus

8.13.4 JTAG Timing

Table 31. JTAG Timing

Characteristic	Symbol	Min	Max	Unit	See Figure
TCK frequency of operation ¹	f_{OP}	DC	SYS_CLK/8	MHz	Figure 32
TCK clock pulse width	t_{PW}	50	—	ns	Figure 32
TMS, TDI data set-up time	t_{DS}	5	—	ns	Figure 33
TMS, TDI data hold time	t_{DH}	5	—	ns	Figure 33
TCK low to TDO data valid	t_{DV}	—	30	ns	Figure 33
TCK low to TDO tri-state	t_{TS}	—	30	ns	Figure 33

¹ TCK frequency of operation must be less than 1/8 the processor rate.

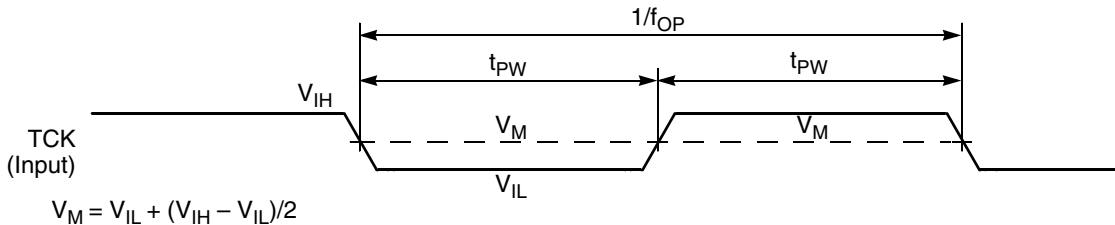

Figure 32. Test Clock Input Timing Diagram

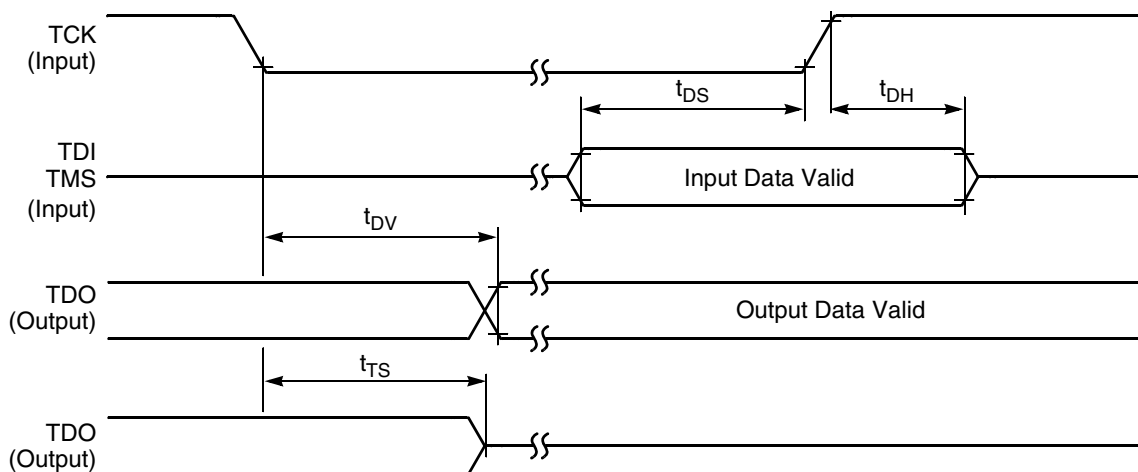

Figure 33. Test Access Port Timing Diagram

8.13.5 Dual Timer Timing

Table 32. Timer Timing^{1, 2}

Characteristic	Symbol	Min	Max	Unit	See Figure
Timer input period	P_{IN}	$2T + 6$	—	ns	Figure 34
Timer input high/low period	P_{INHL}	$1T + 3$	—	ns	Figure 34
Timer output period	P_{OUT}	125	—	ns	Figure 34
Timer output high/low period	P_{OUTHL}	50	—	ns	Figure 34

¹ In the formulas listed, T = the clock cycle. For 32 MHz operation, T = 31.25ns.

² Parameters listed are guaranteed by design.

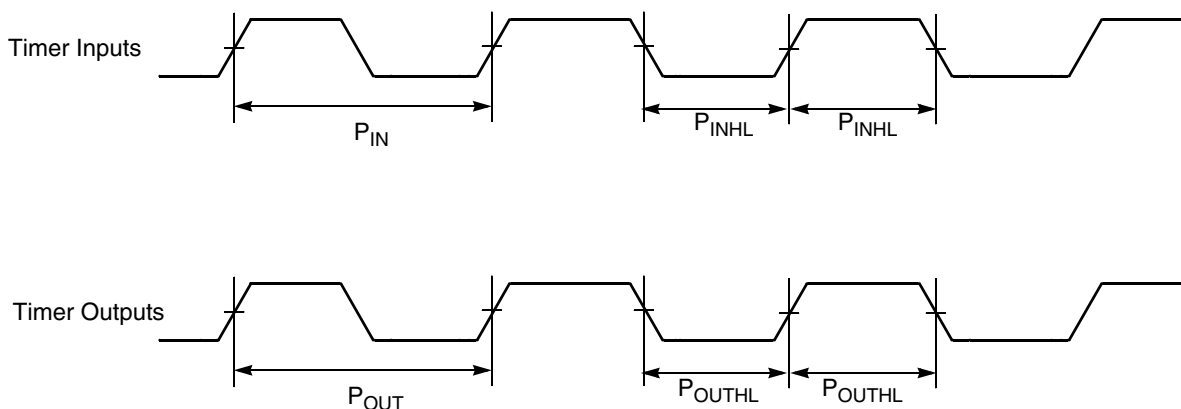

Figure 34. Timer Timing

8.14 COP Specifications

Table 33. COP Specifications

Parameter	Symbol	Min	Typ	Max	Unit
Oscillator output frequency	LPFosc	500	1000	1500	Hz
Oscillator current consumption in partial power down mode	IDD		TBD		nA

8.15 PGA Specifications

Table 34. PGA Specifications

Parameter	Symbol	Min	Max	Unit
Digital logic inputs amplitude (_2p5 signal)	V_{2p5}		2.75	V
DC analog input level (@ $V_{DD} = avdd3p3$) PGA S/H stage enabled (BP=0) PGA S/H stage disabled (BP=1)	V_{IL}	0	V_{DD} $V_{DD} - 0.5$	V
Max differential input voltage (@ Gain and $V_{DD} = avdd3p3$)	$V_{DIFFMAX}$		$(V_{DD} - 1) \times 0.5/\text{gain}$	V
Linearity (@ voltage gain) 1x 2x 4x 8x 16x 32x	L_V	1 – 1/2 LSB 2 – 1/2 LSB 4 – 1 LSB 8 – 1 LSB 16 – 4 LSB 32 – 4 LSB	1 + 1/2 LSB 2 + 1/2 LSB 4 + 1 LSB 8 + 1 LSB 16 + 4 LSB 32 + 4 LSB	V/V
Gain error (@ voltage gain) 1x 2x 4x 8x 16x 32x	A_V		1%	V/V
Sampling frequency (pga_clk_2p5) normal mode (pga_lp_2p5 asserted) low power mode (pga_lp_2p5 negated)	SF_{max}		8 4	MHz
Input signal bandwidth Motor Control mode (BP=0) General Purpose mode (BP=1)	BW_{max}		PGA sampling rate/2 PGA sampling rate/8	Hz
Internal voltage doubler clock frequency(pga_clk_doubler_2p5)	VD_{clk}	100	2000	kHz
Operating temperature	T	-40	125	°C

8.16 ADC Specifications

Table 35. ADC Operating Conditions

Characteristic	Conditions	Symb	Min	Typ ¹	Max	Unit	Comment
Input voltage		V_{ADIN}	V_{REFL} ²	—	V_{REFH} ³	V	
Input capacitance		C_{ADIN}	—	4.5	5.5	pF	
Input resistance		R_{ADIN}	—	5	7	k Ω	
Analog source resistance	12-bit mode $f_{ADCK} > 4$ MHz $f_{ADCK} < 4$ MHz	R_{AS}	—	—	2	k Ω	External to MCU
	10-bit mode $f_{ADCK} > 4$ MHz $f_{ADCK} < 4$ MHz		—	—	5		
	8-bit mode (all valid f_{ADCK})		—	—	10		
ADC conversion clock freq.	High speed (ADLPC=0)	f_{ADCK}	0.4	—	8.0	MHz	
	Low power (ADLPC=1)		0.4	—	4.0		

¹ Typical values assume $V_{DDAD} = 3.0$ V, Temp = 25°C, $f_{ADCK} = 1.0$ MHz unless otherwise stated. Typical values are for reference only and are not tested in production.

² $V_{REFL} = V_{SSA}$

³ $V_{REFH} = V_{DDA}$

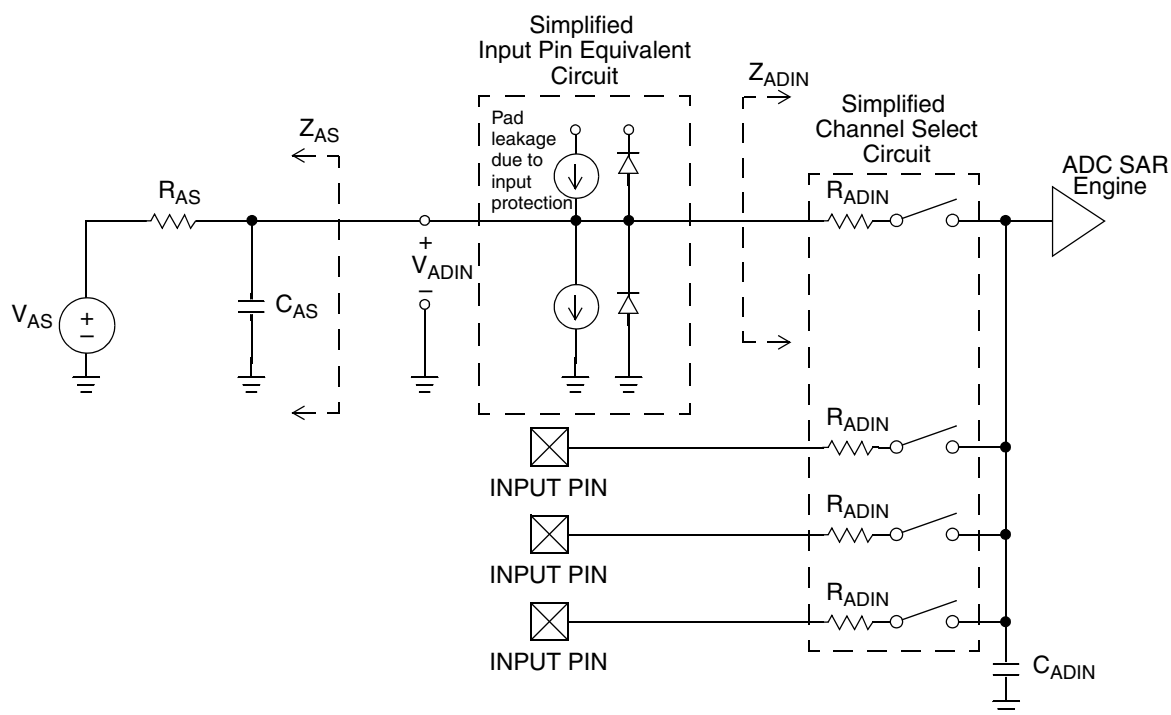

Figure 35. ADC Input Impedance Equivalency Diagram

Specifications

Table 36. ADC Characteristics ($V_{REFH} = V_{DDA}$, $V_{REFL} = V_{SSA}$)

Characteristic	Conditions	Symb	Min	Typ ¹	Max	Unit	Comment
Supply current ADLPC=1 ADLSMP=1 ADCO=1		I_{DDAD}	—	120	—	μA	
Supply current ADLPC=1 ADLSMP=0 ADCO=1		I_{DDAD}	—	202	—	μA	
Supply current ADLPC=0 ADLSMP=1 ADCO=1		I_{DDAD}	—	288	—	μA	
Supply current ADLPC=0 ADLSMP=0 ADCO=1		I_{DDAD}	—	0.532	1	mA	
ADC asynchronous clock source	High speed (ADLPC=0)	f_{ADACK}	2	3.3	5	MHz	$t_{ADACK} = 1/f_{ADACK}$
	Low power (ADLPC=1)		1.25	2	3.3		
Conversion time (including sample time)	Short sample (ADLSMP=0)	t_{ADC}	—	20	—	ADCK cycles	
	Long sample (ADLSMP=1)		—	40	—		
Sample time	Short sample (ADLSMP=0)	t_{ADS}	—	3.5	—	ADCK cycles	
	Long sample (ADLSMP=1)		—	23.5	—		
Differential Non-linearity	12-bit mode	DNL	—	± 1.75	—	LSB^2	
	10-bit mode ³		—	± 0.5	± 1.0		
	8-bit mode ³		—	± 0.3	± 0.5		
Integral non-linearity	12-bit mode	INL	—	± 1.5	—	LSB^2	
	10-bit mode		—	± 0.5	± 1.0		
	8-bit mode		—	± 0.3	± 0.5		
Quantization error	12-bit mode	E_Q	—	-1 to 0	—	LSB^2	
	10-bit mode		—	—	± 0.5		
	8-bit mode		—	—	± 0.5		
Input leakage error	12-bit mode	E_{IL}	—	± 2	—	LSB^2	Pad leakage ^{4 *} R_{AS}
	10-bit mode		—	± 0.2	± 4		
	8-bit mode		—	± 0.1	± 1.2		
Temp sensor slope	-40°C–25°C	m	—	1.646	—	mV/°C	
	25°C–125°C		—	1.769	—		
Temp sensor voltage	25°C	V_{TEMP25}	—	701.2	—	mV	

- ¹ Typical values assume $V_{DDA} = 3.0\text{ V}$, $\text{Temp} = 25^\circ\text{C}$, $f_{ADCK} = 1.0\text{ MHz}$ unless otherwise stated. Typical values are for reference only and are not tested in production.
- ² $1\text{ LSB} = (V_{REFH} - V_{REFL})/2^N$
- ³ Monotonicity and no-missing-codes guaranteed in 10-bit and 8-bit modes
- ⁴ Based on input pad leakage current. Refer to pad electricals.

8.17 HSCMP Specifications

Table 37. HSCMP Specifications

Parameter	Symbol	Min	Typ	Max	Unit
Supply voltage	V_{PWR}	1.8		3.6	V
Supply current, high speed mode (EN=1, PMODE=1, $V_{DDA} \geq V_{LVI_trip}$)	I_{DDAHS}		150		μA
Supply current, low speed mode (EN=1, PMODE=0)	I_{DDALS}		10		μA
Supply current, off mode (EN=0,)	I_{DDAOFF}			100	nA
Analog input voltage	V_{AIN}	$V_{SSA} - 0.01$		$V_{DDA} + 0.01$	V
Analog input offset voltage	V_{AIO}			40	mV
Analog comparator hysteresis	V_H	3.0		20.0	mV
Propagation Delay, high speed mode (EN=1, PMODE=1), $2.4\text{ V} < V_{DDA} < 3.6\text{ V}$	t_{DHSN}^1		70	140	ns
Propagation Delay, High Speed Mode (EN=1, PMODE=1), $1.8\text{ V} < V_{DDA} < 2.4\text{ V}$	t_{DHSB}^2		70	249	ns
Propagation Delay, Low Speed Mode (EN=1, PMODE=0), $2.4\text{ V} < V_{DDA} < 3.6\text{ V}$	t_{AINIT}^3		400	600	ns
Propagation Delay, Low Speed Mode (EN=1, PMODE=0), $1.8\text{ V} < V_{DDA} < 2.4\text{ V}$	t_{AINIT}^4		400	600	ns

¹ Measured with an input waveform that switches 30 mV above and below the reference, to the CMPO output pin. $V_{DDA} > V_{LVI_WARNING} \Rightarrow \text{LVI_WARNING NOT ASSERTED}$.

² Measured with an input waveform that switches 30mV above and below the reference, to the CMPO output pin. $V_{DDA} < V_{LVI_WARNING} \Rightarrow \text{LVI_WARNING ASSERTED}$.

³ Measured with an input waveform that switches 30mV above and below the reference, to the CMPO output pin. $V_{DDA} > V_{LVI_WARNING} \Rightarrow \text{LVI_WARNING NOT ASSERTED}$.

⁴ Measured with an input waveform that switches 30mV above and below the reference, to the CMPO output pin. $V_{DDA} < V_{LVI_WARNING} \Rightarrow \text{LVI_WARNING ASSERTED}$.

8.18 Optimize Power Consumption

See Section 8.6, “Supply Current Characteristics,” for a list of I_{DD} requirements for the 56F8006/56F8002. This section provides additional detail that can be used to optimize power consumption for a given application.

Specifications

Power consumption is given by the following equation:

Eqn. 1

$$\begin{aligned} \text{Total power} = & \quad \text{A:} \quad \text{internal [static component]} \\ & \quad \text{+B:} \quad \text{internal [state-dependent component]} \\ & \quad \text{+C:} \quad \text{internal [dynamic component]} \\ & \quad \text{+D:} \quad \text{external [dynamic component]} \\ & \quad \text{+E:} \quad \text{external [static component]} \end{aligned}$$

A, the internal [static] component, is comprised of the DC bias currents for the oscillator, leakage currents, PLL, and voltage references. These sources operate independently of processor state or operating frequency.

B, the internal [state-dependent] component, reflects the supply current required by certain on-chip resources only when those resources are in use. These include RAM, flash memory, and the ADCs.

C, the internal [dynamic] component, is classic $C \cdot V^2 \cdot F$ CMOS power dissipation corresponding to the 56800E core and standard cell logic.

D, the external [dynamic] component, reflects power dissipated on-chip as a result of capacitive loading on the external pins of the chip. This is also commonly described as $C \cdot V^2 \cdot F$, although simulations on two of the I/O cell types used on the 56800E reveal that the power-versus-load curve does have a non-zero Y-intercept.

Table 38. I/O Loading Coefficients at 10 MHz

	Intercept	Slope
8 mA drive	1.3	0.11 mW/pF
4 mA drive	1.15 mW	0.11 mW/pF

Power due to capacitive loading on output pins is (first order) a function of the capacitive load and frequency at which the outputs change. Table 38 provides coefficients for calculating power dissipated in the I/O cells as a function of capacitive load. In these cases:

$$\text{TotalPower} = \Sigma((\text{Intercept} + \text{Slope} \cdot \text{Cload}) \cdot \text{frequency} / 10 \text{ MHz}) \quad \text{Eqn. 2}$$

where:

- Summation is performed over all output pins with capacitive loads
- Total power is expressed in mW
- C_{load} is expressed in pF

Because of the low duty cycle on most device pins, power dissipation due to capacitive loads was found to be fairly low when averaged over a period of time.

E, the external [static component], reflects the effects of placing resistive loads on the outputs of the device. Sum the total of all V^2/R or IV to arrive at the resistive load contribution to power. Assume $V = 0.5$ for the purposes of these rough calculations. For instance, if there is a total of eight PWM outputs driving 10 mA into LEDs, then $P = 8 \cdot 0.5 \cdot 0.01 = 40 \text{ mW}$.

In previous discussions, power consumption due to parasitics associated with pure input pins is ignored, as it is assumed to be negligible.

9 Design Considerations

9.1 Thermal Design Considerations

An estimation of the chip junction temperature, T_J , can be obtained from the equation:

$$T_J = T_A + (R_{\theta JA} \times P_D) \quad \text{Eqn. 3}$$

where:

$$\begin{aligned} T_A &= \text{Ambient temperature for the package (}^\circ\text{C)} \\ R_{\theta JA} &= \text{Junction-to-ambient thermal resistance (}^\circ\text{C/W)} \\ P_D &= \text{Power dissipation in the package (W)} \end{aligned}$$

The junction-to-ambient thermal resistance is an industry-standard value that provides a quick and easy estimation of thermal performance. Unfortunately, there are two values in common usage: the value determined on a single-layer board and the value obtained on a board with two planes. For packages such as the PBGA, these values can be different by a factor of two. Which value is closer to the application depends on the power dissipated by other components on the board. The value obtained on a single layer board is appropriate for the tightly packed printed circuit board. The value obtained on the board with the internal planes is usually appropriate if the board has low-power dissipation and the components are well separated.

When a heat sink is used, the thermal resistance is expressed as the sum of a junction-to-case thermal resistance and a case-to-ambient thermal resistance:

$$R_{\theta JA} = R_{\theta JC} + R_{\theta CA} \quad \text{Eqn. 4}$$

where:

$$\begin{aligned} R_{\theta JA} &= \text{Package junction-to-ambient thermal resistance (}^\circ\text{C/W)} \\ R_{\theta JC} &= \text{Package junction-to-case thermal resistance (}^\circ\text{C/W)} \\ R_{\theta CA} &= \text{Package case-to-ambient thermal resistance (}^\circ\text{C/W)} \end{aligned}$$

$R_{\theta JC}$ is device related and cannot be adjusted. You control the thermal environment to change the case to ambient thermal resistance, $R_{\theta CA}$. For instance, you can change the size of the heat sink, the air flow around the device, the interface material, the mounting arrangement on printed circuit board, or change the thermal dissipation on the printed circuit board surrounding the device.

To determine the junction temperature of the device in the application when heat sinks are not used, the thermal characterization parameter (Ψ_{JT}) can be used to determine the junction temperature with a measurement of the temperature at the top center of the package case using the following equation:

$$T_J = T_T + (\Psi_{JT} \times P_D) \quad \text{Eqn. 5}$$

where:

$$\begin{aligned} T_T &= \text{Thermocouple temperature on top of package (}^\circ\text{C)} \\ \Psi_{JT} &= \text{Thermal characterization parameter (}^\circ\text{C/W)} \\ P_D &= \text{Power dissipation in package (W)} \end{aligned}$$

The thermal characterization parameter is measured per JESD51–2 specification using a 40-gauge type T thermocouple epoxied to the top center of the package case. The thermocouple should be positioned so that the thermocouple junction rests on the package. A small amount of epoxy is placed over the thermocouple junction and over about 1 mm of wire extending from the

Design Considerations

junction. The thermocouple wire is placed flat against the package case to avoid measurement errors caused by cooling effects of the thermocouple wire.

When heat sink is used, the junction temperature is determined from a thermocouple inserted at the interface between the case of the package and the interface material. A clearance slot or hole is normally required in the heat sink. Minimizing the size of the clearance is important to minimize the change in thermal performance caused by removing part of the thermal interface to the heat sink. Because of the experimental difficulties with this technique, many engineers measure the heat sink temperature and then back-calculate the case temperature using a separate measurement of the thermal resistance of the interface. From this case temperature, the junction temperature is determined from the junction-to-case thermal resistance.

9.2 Electrical Design Considerations

CAUTION

This device contains protective circuitry to guard against damage due to high static voltage or electrical fields. However, take normal precautions to avoid application of any voltages higher than maximum-rated voltages to this high-impedance circuit. Reliability of operation is enhanced if unused inputs are tied to an appropriate voltage level.

Use the following list of considerations to assure correct operation of the 56F8006/56F8002:

- Provide a low-impedance path from the board power supply to each V_{DD} pin on the 56F8006/56F8002 and from the board ground to each V_{SS} (GND) pin.
- The minimum bypass requirement is to place 0.01–0.1 μF capacitors positioned as near as possible to the package supply pins. The recommended bypass configuration is to place one bypass capacitor on each of the V_{DD}/V_{SS} pairs, including V_{DDA}/V_{SSA} . Ceramic and tantalum capacitors tend to provide better tolerances.
- Ensure that capacitor leads and associated printed circuit traces that connect to the chip V_{DD} and V_{SS} (GND) pins are as short as possible.
- Bypass the V_{DD} and V_{SS} with approximately 100 μF , plus the number of 0.1 μF ceramic capacitors.
- PCB trace lengths should be minimal for high-frequency signals.
- Consider all device loads as well as parasitic capacitance due to PCB traces when calculating capacitance. This is especially critical in systems with higher capacitive loads that could create higher transient currents in the V_{DD} and V_{SS} circuits.
- Take special care to minimize noise levels on the V_{REF} , V_{DDA} , and V_{SSA} pins.
- Using separate power planes for V_{DD} and V_{DDA} and separate ground planes for V_{SS} and V_{SSA} are recommended. Connect the separate analog and digital power and ground planes as near as possible to power supply outputs. If an analog circuit and digital circuit are powered by the same power supply, you should connect a small inductor or ferrite bead in serial with V_{DDA} and V_{SSA} traces.
- Physically separate analog components from noisy digital components by ground planes. Do not place an analog trace in parallel with digital traces. Place an analog ground trace around an analog signal trace to isolate it from digital traces.
- Because the flash memory is programmed through the JTAG/EOnCE port, SPI, SCI, or I²C, the designer should provide an interface to this port if in-circuit flash programming is desired.
- If desired, connect an external RC circuit to the $\overline{\text{RESET}}$ pin. The resistor value should be in the range of 4.7 k Ω –10 k Ω ; the capacitor value should be in the range of 0.22 μF –4.7 μF .
- Configuring the $\overline{\text{RESET}}$ pin to GPIO output in normal operation in a high-noise environment may help to improve the performance of noise transient immunity.
- Add a 2.2 k Ω external pullup on the TMS pin of the JTAG port to keep EOnCE in a restate during normal operation if JTAG converter is not present.
- During reset and after reset but before I/O initialization, all I/O pins are at input state with internal pullup enabled. The typical value of internal pullup is around 33 k Ω . These internal pullups can be disabled by software.
- To eliminate PCB trace impedance effect, each ADC input should have a no less than 33 pF 10 Ω RC filter.
- External clamp diodes on analog input pins are recommended.

9.3 Ordering Information

Table 39 lists the pertinent information needed to place an order. Consult a Freescale Semiconductor sales office or authorized distributor to determine availability and to order devices.

Table 39. 56F8006/56F8002 Ordering Information

Device	Supply Voltage	Package Type	Pin Count	Frequency (MHz)	Ambient Temperature Range	Order Number
MC56F8002	1.8–3.6 V	Small Outline IC (SOIC)	28	32	–40° to + 105° C	MC56F8002VWL ¹
MC56F8006	1.8–3.6 V	Small Outline IC (SOIC)	28	32	–40° to + 105° C	MC56F8006VWL ¹
MC56F8006	1.8–3.6 V	Low-Profile Quad Flat Pack (LQFP)	32	32	–40° to + 105° C	MC56F8006VLC ¹
MC56F8006	1.8–3.6 V	Low-Profile Quad Flat Pack (LQFP)	48	32	–40° to + 105° C	MC56F8006VLF ¹

¹ This package is RoHS compliant.

10 Package Mechanical Outline Drawings

10.1 28-pin SOIC Package

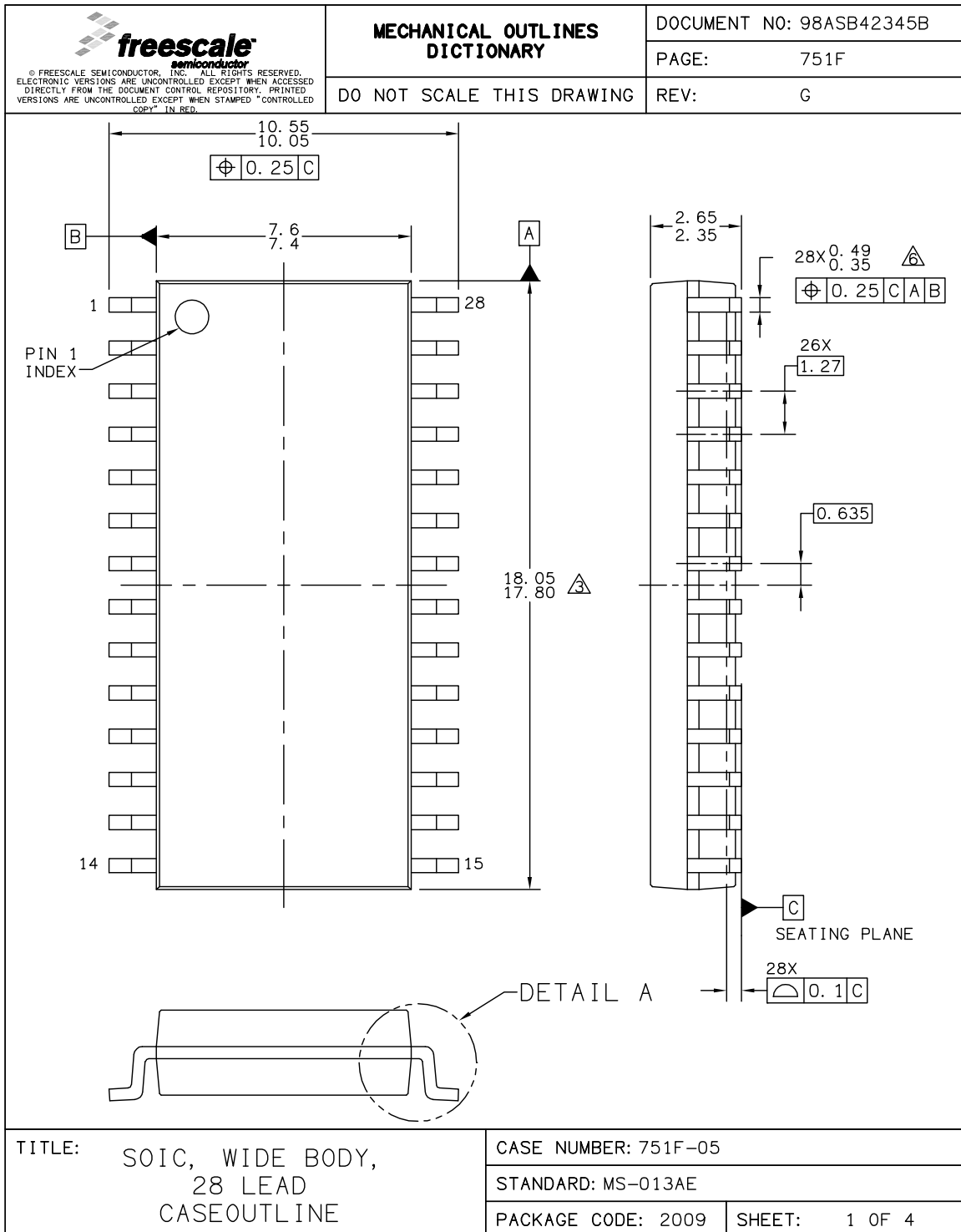

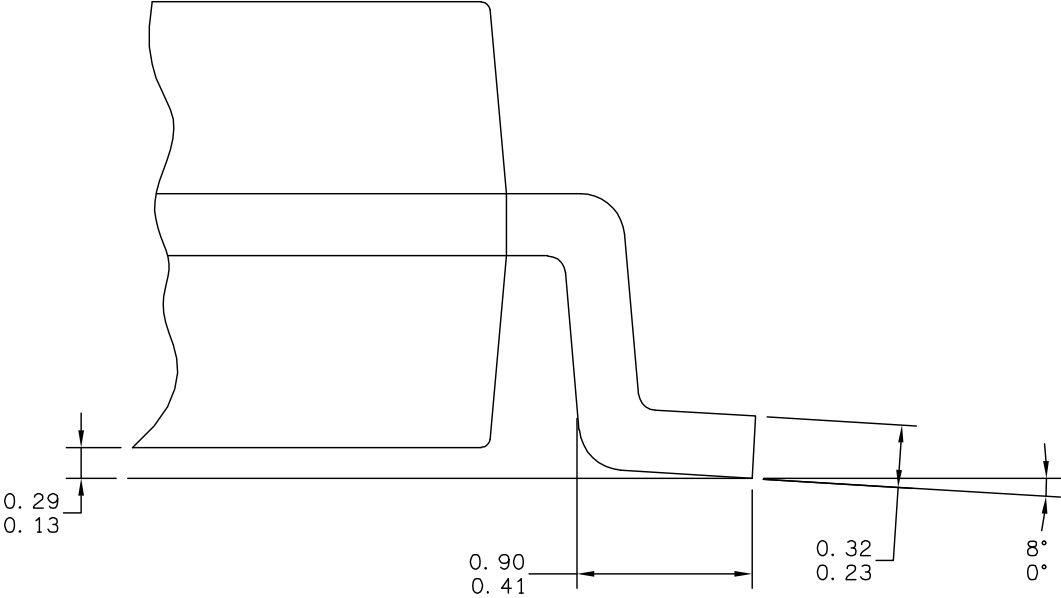
 <p>© FREESCALE SEMICONDUCTOR, INC. ALL RIGHTS RESERVED. ELECTRONIC VERSIONS ARE UNCONTROLLED EXCEPT WHEN ACCESSSED DIRECTLY FROM THE DOCUMENT CONTROL REPOSITORY. PRINTED VERSIONS ARE UNCONTROLLED EXCEPT WHEN STAMPED "CONTROLLED COPY" IN RED.</p>	<p>MECHANICAL OUTLINES DICTIONARY</p>	DOCUMENT NO: 98ASB42345B	
		PAGE:	751F
	DO NOT SCALE THIS DRAWING	REV:	G
			
TITLE: SOIC, WIDE BODY, 28 LEAD CASEOUTLINE		CASE NUMBER: 751F-05	
		STANDARD: MS-013AE	
		PACKAGE CODE: 2009	SHEET: 2 OF 4

Package Mechanical Outline Drawings

 <p>© FREESCALE SEMICONDUCTOR, INC. ALL RIGHTS RESERVED. ELECTRONIC VERSIONS ARE UNCONTROLLED EXCEPT WHEN ACCESSSED DIRECTLY FROM THE DOCUMENT CONTROL REPOSITORY. PRINTED VERSIONS ARE UNCONTROLLED EXCEPT WHEN STAMPED "CONTROLLED COPY" IN RED.</p>	<p>MECHANICAL OUTLINES DICTIONARY</p>	DOCUMENT NO: 98ASB42345B	
		PAGE:	751F
	DO NOT SCALE THIS DRAWING		REV:
<p>NOTES:</p> <ol style="list-style-type: none"> 1. DIMENSIONS ARE IN MILLIMETERS. 2. DIMENSIONING AND TOLERANCING PER ASME Y14.5M-1994. 3. THIS DIMENSION DOES NOT INCLUDE MOLD PROTRUSION. 4. MAXIMUM MOLD PROTRUSION 0.15 PER SIDE. 5. 751F-01 THRU -04 OBSOLETE. NEW STANDARD: 751F-05 6. THIS DIMENSION DOES NOT INCLUDE DAM BAR PROTRUSION ALLOWABLE DAM BAR PROTRUSION SHALL BE 0.13 TOTAL IN EXCESS OF THIS DIMENSION AT MAXIMUM MATERIAL CONDITION. 			
<p>TITLE: SOIC, WIDE BODY, 28 LEAD CASEOUTLINE</p>		CASE NUMBER: 751F-05	
		STANDARD: MS-013AE	
		PACKAGE CODE: 2009	SHEET: 3 OF 4

Figure 36. 56F8006/56F8002 28-Pin SOIC Mechanical Information

10.2 32-pin LQFP

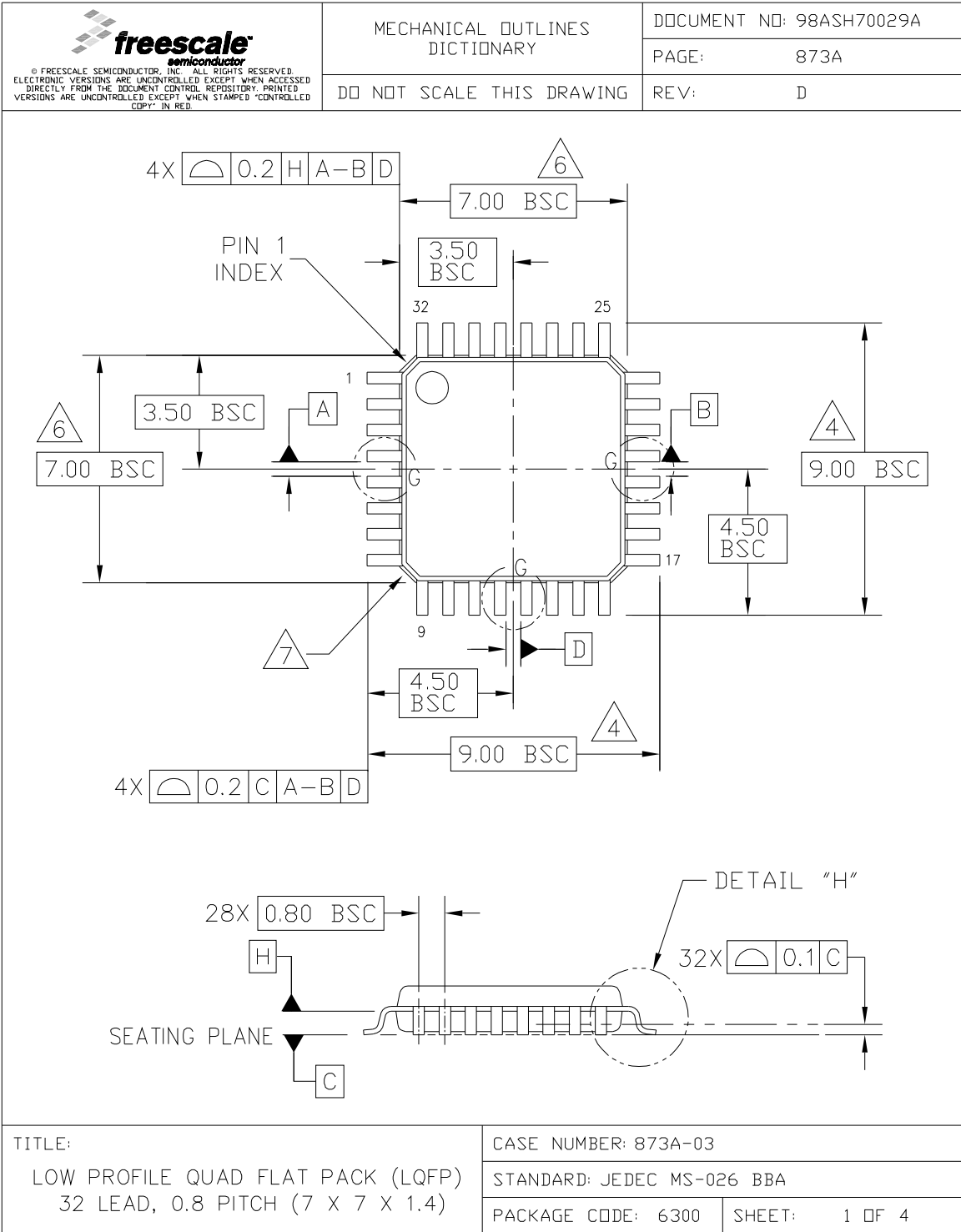

MC56F8006/MC56F8002 Digital Signal Controller, Rev. 2

Package Mechanical Outline Drawings

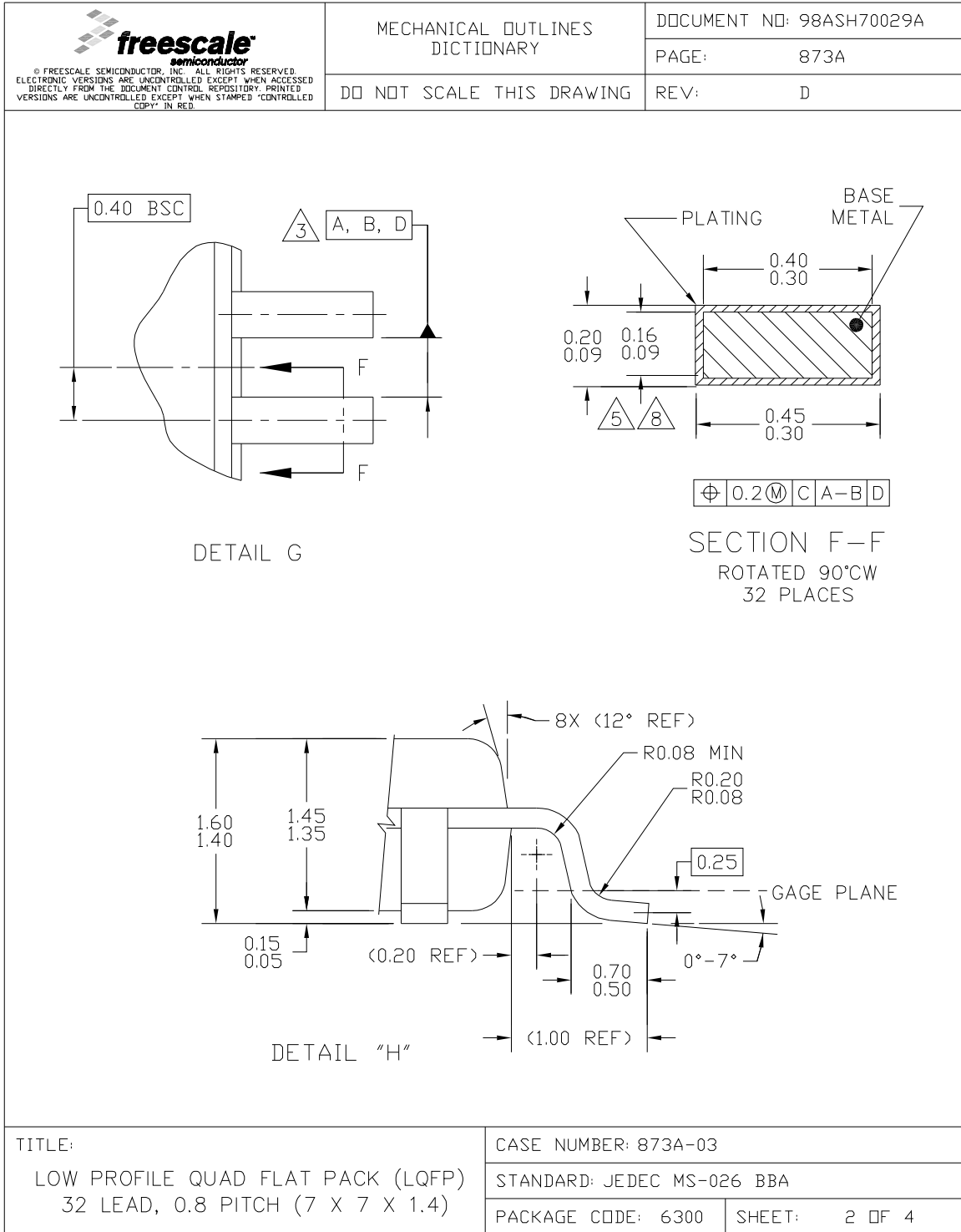

 <p>© FREESCALE SEMICONDUCTOR, INC. ALL RIGHTS RESERVED. ELECTRONIC VERSIONS ARE UNCONTROLLED EXCEPT WHEN ACCESSED DIRECTLY FROM THE DOCUMENT CONTROL REPOSITORY. PRINTED VERSIONS ARE UNCONTROLLED EXCEPT WHEN STAMPED "CONTROLLED COPY" IN RED.</p>	MECHANICAL OUTLINES DICTIONARY		DOCUMENT NO: 98ASH70029A	
	DO NOT SCALE THIS DRAWING		PAGE:	873A
			REV:	D
<p>NOTES:</p> <ol style="list-style-type: none"> 1. DIMENSIONS ARE IN MILLIMETERS. 2. INTERPRET DIMENSIONS AND TOLERANCES PER ASME Y14.5-1994. 3. DATUMS A, B, AND D TO BE DETERMINED AT DATUM PLANE H. 4. DIMENSIONS TO BE DETERMINED AT SEATING PLANE DATUM C. 5. DIMENSION DOES NOT INCLUDE DAMBAR PROTRUSION. ALLOWABLE DAMBAR PROTRUSION SHALL NOT CAUSE THE LEAD WIDTH TO EXCEED THE MAXIMUM DIMENSION BY MORE THAN 0.08 MM. DAMBAR CANNOT BE LOCATED ON THE LOWER RADIUS OR THE FOOT. MINIMUM SPACE BETWEEN PROTRUSION AND ADJACENT LEAD OR PROTRUSION: 0.07 MM. 6. DIMENSIONS DO NOT INCLUDE MOLD PROTRUSION. ALLOWABLE PROTRUSION IS 0.25 MM PER SIDE. DIMENSIONS ARE MAXIMUM PLASTIC BODY SIZE DIMENSIONS INCLUDING MOLD MISMATCH. 7. EXACT SHAPE OF EACH CORNER IS OPTIONAL. 8. THESE DIMENSIONS APPLY TO THE FLAT SECTION OF THE LEAD BETWEEN 0.1 MM AND 0.25 MM FROM THE LEAD TIP. 				
TITLE:		CASE NUMBER: 873A-03		
LOW PROFILE QUAD FLAT PACK (LQFP) 32 LEAD, 0.8 PITCH (7 X 7 X 1.4)		STANDARD: JEDEC MS-026 BBA		
		PACKAGE CODE: 6300	SHEET:	3 OF 4

Figure 37. 56F8006/56F8002 32-Pin LQFP Mechanical Information

10.3 48-pin LQFP

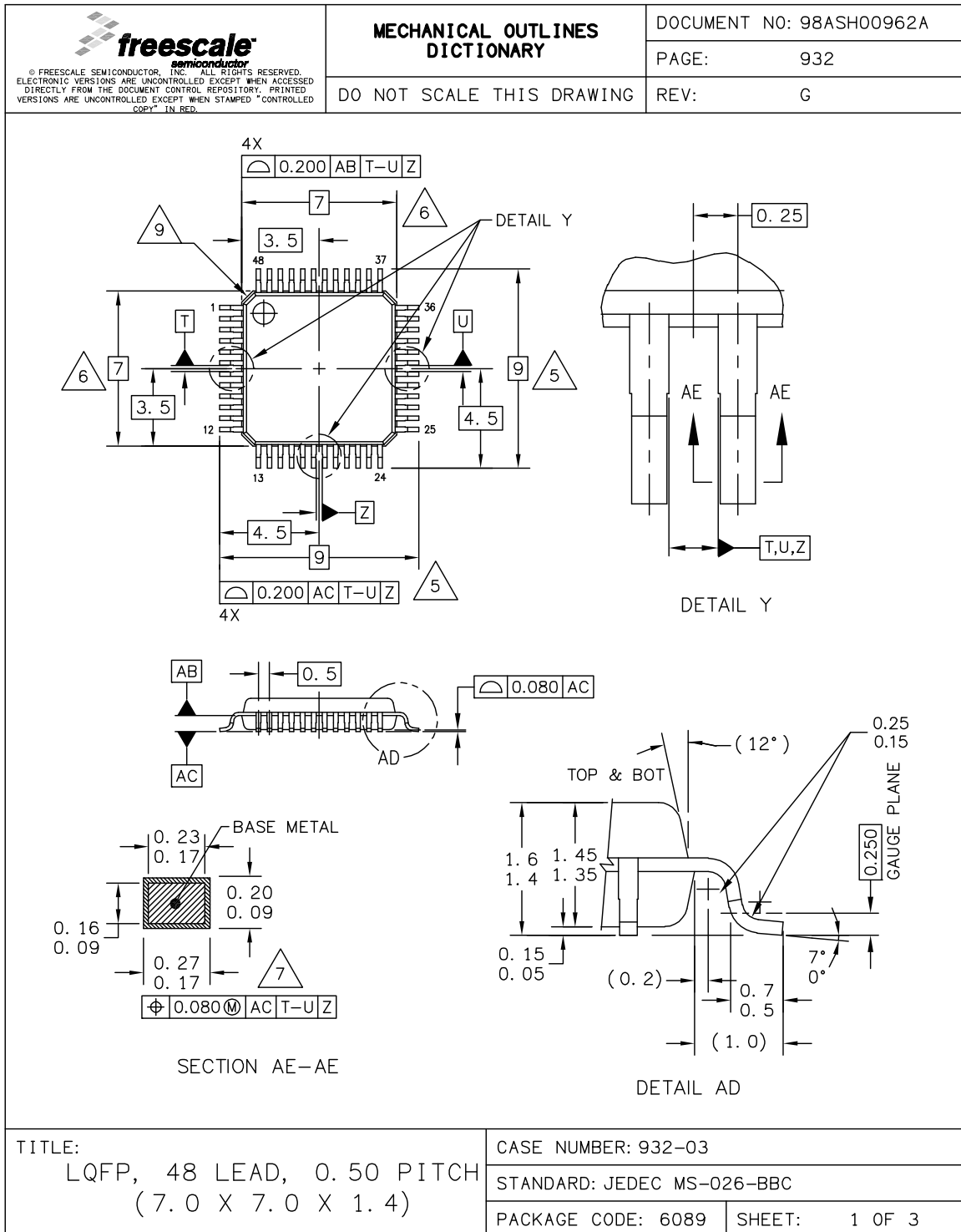

 <p>© FREESCALE SEMICONDUCTOR, INC. ALL RIGHTS RESERVED. ELECTRONIC VERSIONS ARE UNCONTROLLED EXCEPT WHEN ACCESSED DIRECTLY FROM THE DOCUMENT CONTROL REPOSITORY. PRINTED VERSIONS ARE UNCONTROLLED EXCEPT WHEN STAMPED "CONTROLLED COPY" IN RED.</p>	MECHANICAL OUTLINES DICTIONARY	DOCUMENT NO: 98ASH00962A	
		PAGE:	932
DO NOT SCALE THIS DRAWING		REV:	G
<p>NOTES:</p> <ol style="list-style-type: none"> 1. DIMENSIONS AND TOLERANCING PER ASME Y14.5M-1994. 2. CONTROLLING DIMENSION: MILLIMETER. 3. DATUM PLANE AB IS LOCATED AT BOTTOM OF LEAD AND IS COINCIDENT WITH THE LEAD WHERE THE LEAD EXITS THE PLASTIC BODY AT THE BOTTOM OF THE PARTING LINE. 4. DATUMS T, U, AND Z TO BE DETERMINED AT DATUM PLANE AB. 5. DIMENSIONS TO BE DETERMINED AT SEATING PLANE AC. 6. DIMENSIONS DO NOT INCLUDE MOLD PROTRUSION. ALLOWABLE PROTRUSION IS 0.250 PER SIDE. DIMENSIONS DO INCLUDE MOLD MISMATCH AND ARE DETERMINED AT DATUM PLANE AB. 7. THIS DIMENSION DOES NOT INCLUDE DAMBAR PROTRUSION. DAMBAR PROTRUSION SHALL NOT CAUSE THE LEAD WIDTH TO EXCEED 0.350. 8. MINIMUM SOLDER PLATE THICKNESS SHALL BE 0.0076. 9. EXACT SHAPE OF EACH CORNER IS OPTIONAL. 			
TITLE:		CASE NUMBER: 932-03	
LQFP, 48 LEAD, 0.50 PITCH (7.0 X 7.0 X 1.4)		STANDARD: JEDEC MS-026-BBC	
		PACKAGE CODE: 6089	SHEET: 2 OF 3

Figure 38. 56F8006/56F8002 48-Pin LQFP Mechanical Information

Appendix A

Interrupt Vector Table

Table 40 provides the 56F8006/56F8002's reset and interrupt priority structure, including on-chip peripherals. The table is organized with higher-priority vectors at the top and lower-priority interrupts lower in the table. As indicated, the priority of an interrupt can be assigned to different levels, allowing some control over interrupt priorities. All level 3 interrupts are serviced before level 2 and so on. For a selected priority level, the lowest vector number has the highest priority.

The location of the vector table is determined by the vector base address (VBA). Please see the *MC56F8006 Peripheral Reference Manual* for detail.

By default, the chip reset address and COP reset address correspond to vector 0 and 1 of the interrupt vector table. In these instances, the first two locations in the vector table must contain branch or JMP instructions. All other entries must contain JSR instructions.

Table 40. Interrupt Vector Table Contents¹

Peripheral	Vector Number	User Encoding	Priority Level	Vector Base Address +	Interrupt Function
Core				P:0x00	Reserved for Reset Overlay ²
Core				P:0x02	Reserved for COP Reset Overlay
Core	2	N/A	3	P:0x04	Illegal Instruction
Core	3	N/A	3	P:0x06	HW Stack Overflow
Core	4	N/A	3	P:0x08	Misaligned Long Word Access
Core	5	N/A	3	P:0x0A	EOnCE Step Counter
Core	6	N/A	3	P:0x0C	EOnCE Breakpoint Unit
Core	7	N/A	3	P:0x0E	EOnCE Trace Buffer
Core	9	N/A	3	P:0x10	EOnCE Transmit Register Empty
Core	9	N/A	3	P:0x12	EOnCE Receive Register Full
PMC	10	0x0A	0	P:0x14	Low-Voltage Detector
PLL	11	0x0B	0	P:0x16	Phase-Locked Loop Loss of Locks and Loss of Clock
ADCA	12	0x0C	0	P:0x18	ADCA Conversion Complete
ADCB	13	0x0D	0	P:0x1A	ADCB Conversion Complete
PWM	14	0x0E	0	P:0x1C	Reload PWM and/or PWM Faults
CMP0	15	0x0F	0	P:0x1E	Comparator 0 Rising/Falling Flag
CMP1	16	0x10	0	P:0x20	Comparator 1 Rising/Falling Flag
CMP2	17	0x11	0	P:0x22	Comparator 2 Rising/Falling Flag
FM	18	0x12	0	P:0x24	Flash Memory Access Status
SPI	19	0x13	0	P:0x26	SPI Receiver Full
SPI	20	0x14	0	P:0x28	SPI Transmitter Empty
SCI	21	0x15	0	P:0x2A	SCI Transmitter Empty/Idle
SCI	22	0x16	0	P:0x2C	SCI Receiver Full/Overrun/Errors
I ² C	23	0x17	0	P:0x2E	I ² C Interrupt

Table 40. Interrupt Vector Table Contents¹

Peripheral	Vector Number	User Encoding	Priority Level	Vector Base Address +	Interrupt Function
PIT	24	0x18	0	P:0x30	Interval Timer Interrupt
TMR0	25	0x19	0	P:0x32	Dual Timer, Channel 0 Interrupt
TMR1	26	0x1A	0	P:0x34	Dual Timer, Channel 1 Interrupt
GPIOA	27	0x1B	0	P:0x36	GPIOA Interrupt
GPIOB	28	0x1C	0	P:0x38	GPIOB Interrupt
GPIOC	29	0x1D	0	P:0x3A	GPIOC Interrupt
GIPOD	30	0x1E	0	P:0x3C	GIPOD Interrupt
GPIOE	29	0x1F	0	P:0x3E	GPIOE Interrupt
GPIOF	30	0x20	0	P:0x40	GPIOF Interrupt
RTC	33	0x21	0	P:0x42	Real Time Clock
Reserved	34- 39	0x22-0x27	0	P:0x44 - P:0x4E	Reserved
core	40	N/A	0	P:0x50	SW Interrupt 0
core	41	N/A	1	P:0x52	SW Interrupt 1
core	42	N/A	2	P:0x54	SW Interrupt 2
core	43	N/A	3	P:0x56	SW Interrupt 3
SWILP	44	N/A	-1	P:0x58	SW Interrupt Low Priority
USER1	45	N/A	1	P:0x5A	User Programmable Priority Level 1 Interrupt
USER2	46	N/A	1	P:0x5C	User Programmable Priority Level 1 Interrupt
USER3	47	N/A	1	P:0x5E	User Programmable Priority Level 1 Interrupt
USER4	48	N/A	2	P:0x60	User Programmable Priority Level 2 Interrupt
USER5	49	N/A	2	P:0x62	User Programmable Priority Level 2 Interrupt
USER6 ³	50	N/A	2	P:0x64	User Programmable Priority Level 2 Interrupt

¹ Two words are allocated for each entry in the vector table. This does not allow the full address range to be referenced from the vector table, providing only 19 bits of address.

² If the VBA is set to the reset value, the first two locations of the vector table overlay the chip reset addresses because the reset address would match the base of this vector table.

³ USER6 vector can be defined as a fast interrupt if the instruction located in this vector location is not a JSR or BSR instruction. Please see section 9.3.3.3 of *DSP56800E 16-Bit Core Reference Manual* for detail.

Appendix B Peripheral Register Memory Map and Reset Value

Table 10-41. Detailed Peripheral Memory Map

Offset Addr. (Hex)	Reset Value (Hex)	Periph.	Register	Bit 15	14	13	12	11	10	9	8	7	6	5	4	3	2	1	Bit 0	
00	0000	TMR0	TMR0_ COMP1	COMPARISON_1																
01	0000	TMR0	TMR0_ COMP2	COMPARISON_2																
02	0000	TMR0	TMR0_ CAPT	CAPTURE																
03	0000	TMR0	TMR0_ LOAD	LOAD																
04	0000	TMR0	TMR0_ HOLD	HOLD																
05	0000	TMR0	TMR0_ CNTR	COUNTER																
06	0000	TMR0	TMR0_ CTRL	CM			PCS				SCS		ONCE	LENGTH	DIR	Co_INIT	OM			
07	0000	TMR0	TMR0_ SCTRL	TCF	TCFIE	TOF	TOFIE	IEF	IEFIE	IPS	INPUT	CAPTURE_ MODE		MSTR	EEOF	VAL	FORCE	OPS	OEN	
08	0000	TMR0	TMR0_ CMPLD1	COMPARATOR_LOAD_1																
09	0000	TMR0	TMR0_ CMPLD2	COMPARATOR_LOAD_2																
0A	0000	TMR0	TMR0_ CSCTRL	DBG_EN		FAULT	ALT_LOAD	0	0	0	0	TCF2EN	TCF1EN	TCF2	TCF1	CL2		CL1		
0B	0000	TMR0	TMR0_ FILT	0	0	0	0	0	FILT_CNT			FILT_PER								

Table 10-41. Detailed Peripheral Memory Map (continued)

Offset Addr. (Hex)	Reset Value (Hex)	Periph.	Register	Bit 15	14	13	12	11	10	9	8	7	6	5	4	3	2	1	Bit 0	
0C-0E	—	TMR0	Reserved	RESERVED																
0F	000F	TMR0	TMR_ENBL	0	0	0	0	0	0	0	0	0	0	0	0	ENBL				
10	0000	TMR1	TMR1_COMP1	COMPARISON_1																
11	0000	TMR1	TMR1_COMP2	COMPARISON_2																
12	0000	TMR1	TMR1_CAPT	CAPTURE																
13	0000	TMR1	TMR1_LOAD	LOAD																
14	0000	TMR1	TMR1_HOLD	HOLD																
15	0000	TMR1	TMR1_CNTR	COUNTER																
16	0000	TMR1	TMR1_CTRL	CM			PCS				SCS		ONCE	LENGTH	DIR	COINIT	OM			
17	0000	TMR1	TMR1_SCTRL	TCF	TCFIE	TOF	TOFIE	IEF	IEFIE	IPS	INPUT	CAPTURE_MODE	MSTR	EEOF	VAL	FORCE	OPS	OEN		
18	0000	TMR1	TMR1_CMPLD1	COMPARATOR_LOAD_1																
19	0000	TMR1	TMR1_CMPLD2	COMPARATOR_LOAD_2																
1A	0000	TMR1	TMR1_CSCTRL	DBG_EN		0	0	0	0	0	0	TCF2EN	TCF1EN	TCF2	TCF1	CL2		CL1		
1B	0000	TMR1	TMR1_FILT	0	0	0	0	0	FILT_CNT			FILT_PER								

Table 10-41. Detailed Peripheral Memory Map (continued)

Offset Addr. (Hex)	Reset Value (Hex)	Periph.	Register	Bit 15	14	13	12	11	10	9	8	7	6	5	4	3	2	1	Bit 0
1C-1F	—	TMR1	Reserved	RESERVED															
20	0000	PWM	PWM_CTRL	LDFQ				HALF	IPOL2	IPOL1	IPOL0	PRSC		PWMRIE	PWMF	ISENS		LDOK	PWMEN
21	0000	PWM	PWM_FCTRL	0	0	0	0	FPOL3	FPOL2	FPOL1	FPOL0	FIE3	FMODE3	FIE2	FMODE2	FIE1	FMODE1	FIE0	FMODE0
22	0000	PWM	PWM_FLTACK	FPIN3	FFLAG3	FPIN2	FFLAG2	FPIN1	FFLAG1	FPIN0	FFLAG0		FTACK3		FTACK2		FTACK1		FTACK0
23	0000	PWM	PWM_OUT	PAD_EN	0	OUTCTL5	OUTCTL4	OUTCTL3	OUTCTL2	OUTCTL1	OUTCTL0	0	0	OUT5	OUT4	OUT3	OUT2	OUT1	OUT0
24	0000	PWM	PWM_CNTR	0	CR														
25	0000	PWM	PWM_CMOD	0	PWMCM														
26	0000	PWM	PWM_VAL0	PMVAL															
27	0000	PWM	PWM_VAL1	PMVAL															
28	0000	PWM	PWM_VAL2	PMVAL															
29	0000	PWM	PWM_VAL3	PMVAL															
2A	0000	PWM	PWM_VAL4	PMVAL															
2B	0000	PWM	PWM_VAL5	PMVAL															

Table 10-41. Detailed Peripheral Memory Map (continued)

Offset Addr. (Hex)	Reset Value (Hex)	Periph.	Register	Bit 15	14	13	12	11	10	9	8	7	6	5	4	3	2	1	Bit 0
2C	0FFF	PWM	PWM_DTIM0	0	0	0	0	PWMDT0											
2D	0FFF	PWM	PWM_DTIM1	0	0	0	0	PWMDT1											
2E	FFFF	PWM	PWM_DMAP1	DISMAP_15_0															
2F	00FF	PWM	PWM_DMAP2	0	0	0	0	0	0	0	0	DISMAP_23_16							
30	0000	PWM	PWM_CNFG	0	DBG_EN	WAIT_EN	EDG	0	TOPNEG45	TOPNEG23	TOPNEG01	0	BOTNEG45	BOTNEG23	BOTNEG01	INDEP45	INDEP23	INDEP01	WP
31	0000	PWM	PWM_CCTRL	ENHA	nBX	MSK5	MSK4	MSK3	MSK2	MSK1	MSK0	0	0	VLMODE		0	SWP45	SWP23	SWP01
32	00-U ¹	PWM	PWM_PORT	0	0	0	0	0	0	0	0	0	PORT						
33	0000	PWM	PWM_ICCTRL	0	0	0	0	0	0	0	0	0	0	PEC2	PEC1	PEC0	ICC2	ICC1	ICC0
34	0000	PWM	PWM_SCTRL	0	0	CINV5	CINV4	CINV3	CINV2	CINV1	CINV0	0	SRC2		0	SRC1		0	SRC0
35	0000	PWM	PWM_SYNC	SYNC_OUT_EN	SYNC_WINDOW														
36	0000	PWM	PWM_FFILT0	GSTR0	0	0	0	0	FILT0_CNT			FILT0_PER							
37	0000	PWM	PWM_FFILT1	GSTR1	0	0	0	0	FILT1_CNT			FILT1_PER							

Table 10-41. Detailed Peripheral Memory Map (continued)

Offset Addr. (Hex)	Reset Value (Hex)	Periph.	Register	Bit 15	14	13	12	11	10	9	8	7	6	5	4	3	2	1	Bit 0
38	0000	PWM	PWM_FFILT2	GSTR2	0	0	0	0	FILT2_CNT				FILT2_PER						
39	0000	PWM	PWM_FFILT3	GSTR3	0	0	0	0	FILT3_CNT				FILT3_PER						
3B–3F	—	PWM	Reserved	RESERVED															
40	0000	INTC	INTC_ICSR	INT	IPIC		VAB						INT_DIS	ERRF	ETRE	TRBUF	BKPT	STPCNT	
41	0000	INTC	INTC_VBA	0	0	VECTOR_BASE_ADDRESS													
42	0000	INTC	INTC_IAR0	0	0	USER2				0	0	USER1							
43	0000	INTC	INTC_IAR1	0	0	USER4				0	0	USER3							
44	0000	INTC	INTC_IAR2	0	0	USER6				0	0	USER5							
45–5F	—	INTC	Reserved	RESERVED															
60	001F	ADC0	ADC0_ADCSC1A	0	0	0	0	0	0	0	0	COCO	AIEN	ADCO	ADCH				
61	0000	ADC0	ADC0_ADCSC2	0	0	0	0	0	0	0	0	ADACT	ADTRG	0	0	0	ECC	REFSEL	
62–65	—	ADC0	Reserved	RESERVED															
66	0000	ADC0	ADC0_ADCCFG	0	0	0	0	0	0	0	0	ADLPC	ADIV	ADLSMP	MODE		ADICLK		
67–69	—	ADC0	Reserved	RESERVED															

Table 10-41. Detailed Peripheral Memory Map (continued)

Offset Addr. (Hex)	Reset Value (Hex)	Periph.	Register	Bit 15	14	13	12	11	10	9	8	7	6	5	4	3	2	1	Bit 0
6A	001F	ADC0	ADC0_ADCSC1B	0	0	0	0	0	0	0	0	COCO	AIEN	ADCO	ADCH				
6B	0000	ADC0	ADC0_ADCRA	0	ADR11	ADR10	ADR9	ADR8	ADR7	ADR6	ADR5	ADR4	ADR3	ADR2	ADR1	ADR0	0	0	0
6C	0000	ADC0	ADC0_ADCRB	0	ADR11	ADR10	ADR9	ADR8	ADR7	ADR6	ADR5	ADR4	ADR3	ADR2	ADR1	ADR0	0	0	0
6D–6F	—	ADC0	Reserved	RESERVED															
80	001F	ADC1	ADC1_ADCSC1A	0	0	0	0	0	0	0	0	COCO	AIEN	ADCO	ADCH				
81	0000	ADC1	ADC1_ADCSC2	0	0	0	0	0	0	0	0	ADACT	ADTRG	0	0	0	ECC	REFSEL	
82–85	—	ADC1	Reserved	RESERVED															
86	0000	ADC1	ADC1_ADCCFG	0	0	0	0	0	0	0	0	ADLPC	ADIV	ADLSMP	MODE	ADICLK			
87–89	—	ADC1	Reserved	RESERVED															
8A	001F	ADC1	ADC1_ADCSC1B	0	0	0	0	0	0	0	0	COCO	AIEN	ADCO	ADCH				
8B	0000	ADC1	ADC1_ADCRA	0	ADR11	ADR10	ADR9	ADR8	ADR7	ADR6	ADR5	ADR4	ADR3	ADR2	ADR1	ADR0	0	0	0
8C	0000	ADC1	ADC1_ADCRB	0	ADR11	ADR10	ADR9	ADR8	ADR7	ADR6	ADR5	ADR4	ADR3	ADR2	ADR1	ADR0	0	0	0
8D–8F	—	ADC1	Reserved	RESERVED															
A0	0000	PGA0	PGA0_CNTLO	0	0	0	0	0	0	0	0	TM	GAINSEL				LP	EN	

Table 10-41. Detailed Peripheral Memory Map (continued)

Offset Addr. (Hex)	Reset Value (Hex)	Periph.	Register	Bit 15	14	13	12	11	10	9	8	7	6	5	4	3	2	1	Bit 0
A1	0002	PGA0	PGA0_CNTL1	0	0	0	0	0	0	0	0	0	0	BP	CALMODE		CPD		
A2	000E	PGA0	PGA0_CNTL2	0	0	0	0	0	0	0	0	0	0	SWTRIG	NUM_CLK_GS			ADIV	
A3	0000	PGA0	PGA0_STS	0	0	0	0	0	0	0	0	0	0	0	0	0	0	RUNNING	STCOMP
A4–BF	—	PGA0	Reserved	RESERVED															
C0	0000	PGA1	PGA1_CNTL0	0	0	0	0	0	0	0	0	TM	GAINSEL				LP	EN	
C1	0002	PGA1	PGA1_CNTL1	0	0	0	0	0	0	0	0	0	0	BP	CALMODE		CPD		
C2	000E	PGA1	PGA1_CNTL2	0	0	0	0	0	0	0	0	0	0	SWTRIG	NUM_CLK_GS			ADIV	
C3	0000	PGA1	PGA1_STS	0	0	0	0	0	0	0	0	0	0	0	0	0	0	RUNNING	STCOMP
C4–DF	—	PGA1	Reserved	RESERVED															
E0	0200	SCI	SCI_RATE	SBR													FRAC_SBR		
E1	0000	SCI	SCI_CTRL1	LOOP	SWAI	RSRC	M	WAKE	POL	PE	PT	TEIE	TIEI	RFIE	REIE	TE	RE	RWU	SBK
E2	0000	SCI	SCI_CTRL2	TFCNT			TFWM		RFCNT			RFWM		FIFO_EN	0	LIN_MODE	0	0	0
E3	C000	SCI	SCI_STAT	TDRE	TIDLE	RDRF	RIDLE	OR	NF	FE	PF	0	0	0	0	LSE	0	0	RAF

Table 10-41. Detailed Peripheral Memory Map (continued)

Offset Addr. (Hex)	Reset Value (Hex)	Periph.	Register	Bit 15	14	13	12	11	10	9	8	7	6	5	4	3	2	1	Bit 0
E4	0000	SCI	SCI_DATA	0	0	0	0	0	0	0	RECEIVE_TRANSMIT_DATA								
E5–FF	—	SCI	Reserved	RESERVED															
00	6141	SPI	SPI_SCTRL	SPR			DSO	ERRIE	MODFEN	SPRIE	SPMSTR	CPOL	CPHA	SPE	SPTIE	SPRF	OVRF	MODF	SPTIE
01	000F	SPI	SPI_DSCTRL	WOM	0	0	BD2X	SSB_IN	SSB_DATA	SSB_ODM	SSB_AUTO	SSB_DDR	SSB_STRB	SSB_OVER	SPR3	DS			
02	0000	SPI	SPI_DRCV	R15	R14	R13	R12	R11	R10	R9	R8	R7	R6	R5	R4	R3	R2	R1	R0
03	0000	SPI	SPI_DXMIT	T15	T14	T13	T12	T11	T10	T9	T8	T7	T6	T5	T4	T3	T2	T1	T0
04–1F	—	SPI	Reserved	RESERVED															
20	0000	I2C	I2C_ADDR	0	0	0	0	0	0	0	0	AD7	AD6	AD5	AD4	AD3	AD2	AD1	0
21	0000	I2C	I2C_FREQDIV	0	0	0	0	0	0	0	0	MULT		ICR					
22	0000	I2C	I2C_CR1	0	0	0	0	0	0	0	0	IICEN	IICIE	MST	TX	TXAK	RSTA	0	0
23	0080	I2C	I2C_SR	0	0	0	0	0	0	0	0	TCF	IAAS	BUSY	ARBL	0	SRW	IICIF	RXAK
24	0000	I2C	I2C_DATA	0	0	0	0	0	0	0	0	DATA							
25	0000	I2C	I2C_CR2	0	0	0	0	0	0	0	0	GCAEN	ADEXT	0	0	0	AD10	AD9	AD8
26	0000	I2C	I2C_SMB_CSR	0	0	0	0	0	0	0	0	FAACK	ALERTEN	SIICAEN	TCKSEL	SLTF	SHTF	0	0
27	0000	I2C	I2C_ADDR2	0	0	0	0	0	0	0	0	SAD7	SAD6	SAD5	SAD4	SAD3	SAD2	SAD1	0

Table 10-41. Detailed Peripheral Memory Map (continued)

Offset Addr. (Hex)	Reset Value (Hex)	Periph.	Register	Bit 15	14	13	12	11	10	9	8	7	6	5	4	3	2	1	Bit 0
28	0000	I2C	I2C_SLT1	0	0	0	0	0	0	0	0	SSLT15	SSLT14	SSLT13	SSLT12	SSLT11	SSLT10	SSLT9	SSLT8
29	0000	I2C	I2C_SLT2	0	0	0	0	0	0	0	0	SSLT7	SSLT6	SSLT5	SSLT4	SSLT3	SSLT2	SSLT1	SSLT0
30–3F	—	I2C	Reserved	RESERVED															
40	0302	COP	COP_CTRL	0	0	0	0	0	0	PSS	0	CLKSEL	CLOREN	CSEN	CWEN	CEN	CWP		
41	FFFF	COP	COP_TOUT	TIMEOUT															
42	FFFF	COP	COP_CNTR	COUNT_SERVICE															
43–5F	—	COP	Reserved	RESERVED															
60	0011	OCCS	OCCS_CTRL	PLLIE1	PLLIE0	LOCIE	0	0	0	LCKON	0	0	PLLPD	0	PRECS	ZSRC			
61	2000	OCCS	OCCS_DIVBY	LORTP			COD			0	0	0	0	0	0	0	0	0	0
62	0015	OCCS	OCCS_STAT	LOLI1	LOLI0	LOCI	0	0	0	0	0	0	LCK1	LCK0	PLLPDN	0	COSC_RDY	ZSRC	
64	1611	OCCS	OCCS_OCTRL	ROPD	ROSB	COHL	CLK_MODE	RANGE	EXT_SEL	TRIM									
65	0000	OCCS	OCCS_CLKCHKR	CHK_ENA	REFERENCE_CNT														

Table 10-41. Detailed Peripheral Memory Map (continued)

Offset Addr. (Hex)	Reset Value (Hex)	Periph.	Register	Bit 15	14	13	12	11	10	9	8	7	6	5	4	3	2	1	Bit 0
66	0000	OCCS	OCCS_CLKCHKT	0	0	0	0	0	0	0	0	0	TARGET_CNT						
67	0000	OCCS	OCCS_PROT	0	0	0	0	0	0	0	0	0	0	FRQEP	OSCEP		PLLEP		
68–7F	—	OCCS	Reserved	RESERVED															
80	00FF	GPIOA	GPIOA_PUR	0	0	0	0	0	0	0	0	PU							
81	0000	GPIOA	GPIOA_DR	0	0	0	0	0	0	0	0	D							
82	0000	GPIOA	GPIOA_DDR	0	0	0	0	0	0	0	0	DD							
83	0080	GPIOA	GPIOA_PER	0	0	0	0	0	0	0	0	PE							
84	—	GPIOA	Reserved	RESERVED															
85	0000	GPIOA	GPIOA_IENR	0	0	0	0	0	0	0	0	IEN							
86	0000	GPIOA	GPIOA_IPOLR	0	0	0	0	0	0	0	0	IPOL							
87	0000	GPIOA	GPIOA_IPR	0	0	0	0	0	0	0	0	IP							
88	0000	GPIOA	GPIOA_IESR	0	0	0	0	0	0	0	0	IES							
89	—	GPIOA	Reserved	RESERVED															
8A	0000	GPIOA	GPIOA_RAWDATA	0	0	0	0	0	0	0	0	RAWDATA							
8B	0000	GPIOA	GPIOA_DRIVE	0	0	0	0	0	0	0	0	DRIVE							
8C	00FF	GPIOA	GPIOA_IFE	0	0	0	0	0	0	0	0	IFE							
8D	0000	GPIOA	GPIOA_SLEW	0	0	0	0	0	0	0	0	SLEW							

Table 10-41. Detailed Peripheral Memory Map (continued)

Offset Addr. (Hex)	Reset Value (Hex)	Periph.	Register	Bit 15	14	13	12	11	10	9	8	7	6	5	4	3	2	1	Bit 0
8E–9F	—	GPIOA	Reserved	RESERVED															
A0	00FF	GPIOB	GPIOB_PUR	0	0	0	0	0	0	0	0	PUR							
A1	0000	GPIOB	GPIOB_DR	0	0	0	0	0	0	0	0	DR							
A2	0000	GPIOB	GPIOB_DDR	0	0	0	0	0	0	0	0	DDR							
A3	0080	GPIOB	GPIOB_PER	0	0	0	0	0	0	0	0	PER							
A4	—	GPIOB	Reserved	RESERVED															
A5	0000	GPIOB	GPIOB_IENR	0	0	0	0	0	0	0	0	IENR							
A6	0000	GPIOB	GPIOB_IPOLR	0	0	0	0	0	0	0	0	IPOLR							
A7	0000	GPIOB	GPIOB_IPR	0	0	0	0	0	0	0	0	IPR							
A8	0000	GPIOB	GPIOB_IESR	0	0	0	0	0	0	0	0	IESR							
A9	—	GPIOB	Reserved	RESERVED															
AA	0000	GPIOB	GPIOB_RAWDATA	0	0	0	0	0	0	0	0	RAWDATA							
AB	0000	GPIOB	GPIOB_DRIVE	0	0	0	0	0	0	0	0	DRIVE							
AC	00FF	GPIOB	GPIOB_IFE	0	0	0	0	0	0	0	0	IFE							
AD	0000	GPIOB	GPIOB_SLEW	0	0	0	0	0	0	0	0	SLEW							
AE–BF	—	GPIOB	Reserved	RESERVED															
C0	00FF	GPIOC	GPIOC_PUR	0	0	0	0	0	0	0	0	PUR							

Table 10-41. Detailed Peripheral Memory Map (continued)

Offset Addr. (Hex)	Reset Value (Hex)	Periph.	Register	Bit 15	14	13	12	11	10	9	8	7	6	5	4	3	2	1	Bit 0
C1	0000	GPIOC	GPIOC_DR	0	0	0	0	0	0	0	0	DR							
C2	0000	GPIOC	GPIOC_ DDR	0	0	0	0	0	0	0	0	DDR							
C3	0080	GPIOC	GPIOC_ PER	0	0	0	0	0	0	0	0	PER							
C4	—	GPIOC	Reserved	RESERVED															
C5	0000	GPIOC	GPIOC_ IENR	0	0	0	0	0	0	0	0	IENR							
C6	0000	GPIOC	GPIOC_ IPOLR	0	0	0	0	0	0	0	0	IPOLR							
C7	0000	GPIOC	GPIOC_ IPR	0	0	0	0	0	0	0	0	IPR							
C8	0000	GPIOC	GPIOC_ IESR	0	0	0	0	0	0	0	0	IESR							
C9	—	GPIOC	Reserved	RESERVED															
CA	0000	GPIOC	GPIOC_ RAWDATA	0	0	0	0	0	0	0	0	RAWDATA							
CB	0000	GPIOC	GPIOC_ DRIVE	0	0	0	0	0	0	0	0	DRIVE							
CC	00FF	GPIOC	GPIOC_ IFE	0	0	0	0	0	0	0	0	IFE							
CD	0000	GPIOC	GPIOC_ SLEW	0	0	0	0	0	0	0	0	SLEW							
CE-DF	—	GPIOC	Reserved	RESERVED															
E0	00FF	GPIOD	GPIOD_ PUR	0	0	0	0	0	0	0	0	0	0	0	0	PUR			
E1	0000	GPIOD	GPIOD_DR	0	0	0	0	0	0	0	0	0	0	0	0	DR			
E2	0000	GPIOD	GPIOD_ DDR	0	0	0	0	0	0	0	0	0	0	0	DDR				

Table 10-41. Detailed Peripheral Memory Map (continued)

Offset Addr. (Hex)	Reset Value (Hex)	Periph.	Register	Bit 15	14	13	12	11	10	9	8	7	6	5	4	3	2	1	Bit 0
E3	0080	GPIOD	GPIOD_PER	0	0	0	0	0	0	0	0	0	0	0	0	PER			
E4	—	GPIOD	Reserved	RESERVED															
E5	0000	GPIOD	GPIOD_IENR	0	0	0	0	0	0	0	0	0	0	0	0	IENR			
E6	0000	GPIOD	GPIOD_IPOLR	0	0	0	0	0	0	0	0	0	0	0	0	IPOLR			
E7	0000	GPIOD	GPIOD_IPR	0	0	0	0	0	0	0	0	0	0	0	0	IPR			
E8	0000	GPIOD	GPIOD_IESR	0	0	0	0	0	0	0	0	0	0	0	0	IESR			
E9	—	GPIOD	Reserved	RESERVED															
EA	0000	GPIOD	GPIOD_RAWDATA	0	0	0	0	0	0	0	0	0	0	0	0	RAWDATA			
EB	0000	GPIOD	GPIOD_DRIVE	0	0	0	0	0	0	0	0	0	0	0	0	DRIVE			
EC	00FF	GPIOD	GPIOD_IFE	0	0	0	0	0	0	0	0	0	0	0	0	IFE			
ED	0000	GPIOD	GPIOD_SLEW	0	0	0	0	0	0	0	0	0	0	0	0	SLEW			
EE–9F	—	GPIOD	Reserved	RESERVED															
00	00FF	GPIOE	GPIOE_PUR	0	0	0	0	0	0	0	0	PUR							
01	0000	GPIOE	GPIOE_DR	0	0	0	0	0	0	0	0	DR							
02	0000	GPIOE	GPIOE_DDR	0	0	0	0	0	0	0	0	DDR							
03	0080	GPIOE	GPIOE_PER	0	0	0	0	0	0	0	0	PER							
04	—	GPIOE	Reserved	RESERVED															

Table 10-41. Detailed Peripheral Memory Map (continued)

Offset Addr. (Hex)	Reset Value (Hex)	Periph.	Register	Bit 15	14	13	12	11	10	9	8	7	6	5	4	3	2	1	Bit 0
05	0000	GPIOE	GPIOE_IENR	0	0	0	0	0	0	0	0	IENR							
06	0000	GPIOE	GPIOE_IPOLR	0	0	0	0	0	0	0	0	IPOLR							
07	0000	GPIOE	GPIOE_IPR	0	0	0	0	0	0	0	0	IPR							
08	0000	GPIOE	GPIOE_IESR	0	0	0	0	0	0	0	0	IESR							
09	—	GPIOE	Reserved	RESERVED															
0A	0000	GPIOE	GPIOE_RAWDATA	0	0	0	0	0	0	0	0	RAWDATA							
0B	0000	GPIOE	GPIOE_DRIVE	0	0	0	0	0	0	0	0	DRIVE							
0C	00FF	GPIOE	GPIOE_IFE	0	0	0	0	0	0	0	0	IFE							
0D	0000	GPIOE	GPIOE_SLEW	0	0	0	0	0	0	0	0	SLEW							
0E-1F	—	GPIOE	Reserved	RESERVED															
20	00FF	GPIOF	GPIOF_PUR	0	0	0	0	0	0	0	0	0	0	0	0	PUR			
21	0000	GPIOF	GPIOF_DR	0	0	0	0	0	0	0	0	0	0	0	0	DR			
22	0000	GPIOF	GPIOF_DDR	0	0	0	0	0	0	0	0	0	0	0	0	DDR			
23	0080	GPIOF	GPIOF_PER	0	0	0	0	0	0	0	0	0	0	0	0	PER			
24	—	GPIOF	Reserved	RESERVED															
25	0000	GPIOF	GPIOF_IENR	0	0	0	0	0	0	0	0	0	0	0	0	IENR			
26	0000	GPIOF	GPIOF_IPOLR	0	0	0	0	0	0	0	0	0	0	0	0	IPOLR			

Table 10-41. Detailed Peripheral Memory Map (continued)

Offset Addr. (Hex)	Reset Value (Hex)	Periph.	Register	Bit 15	14	13	12	11	10	9	8	7	6	5	4	3	2	1	Bit 0
27	0000	GPIOF	GPIOF_IPR	0	0	0	0	0	0	0	0	0	0	0	0	IPR			
28	0000	GPIOF	GPIOF_IESR	0	0	0	0	0	0	0	0	0	0	0	0	IESR			
29	—	GPIOF	Reserved	RESERVED															
2A	0000	GPIOF	GPIOF_RAWDATA	0	0	0	0	0	0	0	0	0	0	0	0	RAWDATA			
2B	0000	GPIOF	GPIOF_DRIVE	0	0	0	0	0	0	0	0	0	0	0	0	DRIVE			
2C	00FF	GPIOF	GPIOF_IFE	0	0	0	0	0	0	0	0	0	0	0	0	IFE			
2D	0000	GPIOF	GPIOF_SLEW	0	0	0	0	0	0	0	0	0	0	0	0	SLEW			
2E–3F	—	GPIOF	Reserved	RESERVED															
40	0000	SIM	SIM_CTRL	0	0	0	0	0	0	0	0	0	0	ONCEEBL	SW_RST	STOP_DISABLE		WAIT_DISABLE	
41	0001	SIM	SIM_RSTAT	0	0	0	0	0	0	0	0	0	SWR	COP_CPU	COP_LOR	EXTR	LVDR	PPD	POR
42	01F2	SIM	SIM_MSHID	SIM_MSH_ID															
43	601D	SIM	SIM_LSHID	SIM_LSH_ID															
45	2020	SIM	SIM_CLKOUT	0	0	CLKDIS1	0	0	CLKOSEL1			0	0	CLKDIS0	CLKOSEL0				

Table 10-41. Detailed Peripheral Memory Map (continued)

Offset Addr. (Hex)	Reset Value (Hex)	Periph.	Register	Bit 15	14	13	12	11	10	9	8	7	6	5	4	3	2	1	Bit 0	
46	0000	SIM	SIM_PCR	TMR_CR	0	PWM_CR	SCI_CR	0	0	0	0	0	0	0	0	0	0	0	0	
47	0000	SIM	SIM_PCE	CMP2	CMP1	CMP0	ADC1	ADC0	PGA1	PGA0	I2C	SCI	SPI	PWM	COP	PDB	PIT	TA1	TA0	
48	0000	SIM	SIM_SDR	CMP2	CMP1	CMP0	ADC1	ADC0	PGA1	PGA0	I2C	SCI	SPI	PWM	COP	PDB	PIT	TA1	TA0	
49	F000	SIM	SIM_ISAL	ADDR_15_6											0	0	0	0	0	0
4A	0000	SIM	SIM_PROT	0	0	0	0	0	0	0	0	0	0	0	0	PCEP		GIPSP		
4B	0000	SIM	SIM_GPSPA	0	0	0	0	0	0	0	GPS_A6			GPS_A5		GPS_A4		GPS_A3		
4C	0000	SIM	SIM_GPSB0	GPS_B5		GPS_B4			GPS_B3			GPS_B2		0	GPS_B1		GPS_B0			
4D	0000	SIM	SIM_GPSB1	0	0	0	0	0	0	0	0	0	0	0	0	GPS_B7		GPS_B6		
4E	0000	SIM	SIM_GPSC	0	0	0	0	0	0	0	0	0	0	0	0	0	0	0	GPS_C6	GPS_C0
4F	0000	SIM	SIM_GPSD	0	0	0	0	0	0	0	GPS_D3		GPS_D2		GPS_D1		GPS_D0			
50	0000	SIM	SIM_IPS0	0	0	0	0	IPS_FAULT3	IPS_FAULT2	IPS_FAULT1	IPS_PSRC2			IPS_PSRC1			IPS_PSRC0			
51	0000	SIM	SIM_IPS1	0	IPS_C2_WS			IPS_C1_WS			IPS_C0_WS			IPS_T1		IPS_T0				
52-5F	—	SIM	Reserved	RESERVED																
60	0208	PMC	PMC_SCR	OORF	LVDF	PPDF	PORF	OORIE	LV DIE	LV DRE	PPDE	LPR	LPRS	LPWUI	BGBE	LVDE	LVLS	PROT		

Table 10-41. Detailed Peripheral Memory Map (continued)

Offset Addr. (Hex)	Reset Value (Hex)	Periph.	Register	Bit 15	14	13	12	11	10	9	8	7	6	5	4	3	2	1	Bit 0
61	00-- ²	PMC	PMC_CR2	0	0	0	0	0	0	0	LPO_EN	LPO_TRIM			TRIM				
7F	—	PMC	Reserved	RESERVED															
80	0000	CMP0	CMP0_CR0	0	0	0	0	0	0	0	0	0	FILTER_CNT			PMC		MMC	
81	0000	CMP0	CMP0_CR1	0	0	0	0	0	0	0	0	SE	WE	0	PMODE	INV	COS	OPE	EN
82	0000	CMP0	CMP0_FPR	0	0	0	0	0	0	0	0	FILT_PER							
83	0000	CMP0	CMP0_SCR	0	0	0	0	0	0	0	0	0	0	0	IER	IEF	CFR	CFF	COUT
84–9F	—	CMP0	Reserved	RESERVED															
A0	0000	CMP1	CMP1_CR0	0	0	0	0	0	0	0	0	0	FILTER_CNT			PMC		MMC	
A1	0000	CMP1	CMP1_CR1	0	0	0	0	0	0	0	0	SE	WE	0	PMODE	INV	COS	OPE	EN
A2	0000	CMP1	CMP1_FPR	0	0	0	0	0	0	0	0	FILT_PER							
A3	0000	CMP1	CMP1_SCR	0	0	0	0	0	0	0	0	0	0	0	IER	IEF	CFR	CFF	COUT
A4–BF	—	CMP1	Reserved	RESERVED															
C0	0000	CMP2	CMP2_CR0	0	0	0	0	0	0	0	0	0	FILTER_CNT			PMC		MMC	
C1	0000	CMP2	CMP2_CR1	0	0	0	0	0	0	0	0	SE	WE	0	PMODE	INV	COS	OPE	EN

Table 10-41. Detailed Peripheral Memory Map (continued)

Offset Addr. (Hex)	Reset Value (Hex)	Periph.	Register	Bit 15	14	13	12	11	10	9	8	7	6	5	4	3	2	1	Bit 0
C2	0000	CMP2	CMP2_FPR	0	0	0	0	0	0	0	0	FILT_PER							
C3	0000	CMP2	CMP2_SCR	0	0	0	0	0	0	0	0	0	0	0	IER	IEF	CFR	CFF	COUT
C4-DF	—	CMP2	Reserved	RESERVED															
E0	0000	PIT	PIT_CTRL	0	0	0	0	0	0	0	0	0	PRESCALER				PRF	PRIE	CNT_EN
E1	0000	PIT	PIT_MOD	MODULO_VALUE															
E2	0000	PIT	PIT_CNTR	COUNTER_VALUE															
E3-FF	—	PIT	Reserved	RESERVED															
00	0000	PDB	PDB_SCR	PRESCALER		0	AOS		0	BOS		CONT	SWTRIG	TRIGSEL		ENA		ENB	
01	0000	PDB	PDB_DELAYA	DELAYA															
02	0000	PDB	PDB_DELAYB	DELAYB															
03	FFFF	PDB	PDB_MOD	MOD															
04	FFFF	PDB	PDB_COUNT	COUNT															
05-1F	—	PDB	Reserved	RESERVED															
20	0000	RTC	RTC_SC	0	0	0	0	0	0	0	0	RTIF	RTCLKS	RTIE	RTCPS				
21	0000	RTC	RTC_CNT	0	0	0	0	0	0	0	0	RTCCNT							
22	0000	RTC	RTC_MOD	0	0	0	0	0	0	0	0	RTCMOD							
23-FF	—	RTC	Reserved	RESERVED															

Table 10-41. Detailed Peripheral Memory Map (continued)

Offset Addr. (Hex)	Reset Value (Hex)	Periph.	Register	Bit 15	14	13	12	11	10	9	8	7	6	5	4	3	2	1	Bit 0
00	0000	HFM	FM_CLKDIV	0	0	0	0	0	0	0	0	DIVLD	PRDIV8	DIV					
01	0000	HFM	FM_CNFG	0	0	0	0	0	LOCK	0	AEIE	CBEIE	CCIE	KEYACC	0	0	0	LBTS	BTS
03	-000 ³	HFM	FM_SECHI	KEYEN	SECSTAT	0	0	0	0	0	0	0	0	0	0	0	0	0	0
04	0000	HFM	FM_SECLO	0	0	0	0	0	0	0	0	0	0	0	0	0	0	SEC	
06–0F	—	HFM	Reserved	RESERVED															
10	FFFF ⁶	HFM	FM_PROT	PROTECT															
11	—	HFM	Reserved	RESERVED															
13	00C0	HFM	FM_USTAT	0	0	0	0	0	0	0	0	CBEIF	CCIF	PVIOL	ACCERR	0	BLANK	0	0
14	0000	HFM	FM_CMD	0	0	0	0	0	0	0	0	0	CMD						
17	—	HFM	Reserved	RESERVED															
18	0000	HFM	FM_DATA	FMDATA															
19	—	HFM	Reserved	RESERVED															
1A	FFFF ⁴	HFM	FM_OPT0	IFR_OPT0															
1B	FFFF ⁵	HFM	FM_OPT1	IFR_OPT1															
1D	FFFF ⁶	HFM	FM_TSTSIG	TST_AREA_SIG															
1E–3F	—	HFM	Reserved	RESERVED															

¹ The binary reset value of this register is 0000 0000 0UUU UUUU, where U represents an undefined value. Spaces have been added to the value for clarity.

² The binary reset value of this register is 0000 0000 111NC NC NC NC NC. Spaces have been added to the value for clarity.

- ³ The binary reset value of this register is FS00 0000 0000 0000, where F indicates that the reset state is loaded from the flash array during reset, and where S indicates that the reset state is determined by the security state of the module. Spaces have been added to the value for clarity.
- ⁴ The reset state is loaded from the flash array during reset.
- ⁵ The reset state is loaded from the flash array during reset.
- ⁶ The reset state is loaded from the flash array during reset.

How to Reach Us:

Home Page:

www.freescale.com

Web Support:

<http://www.freescale.com/support>

USA/Europe or Locations Not Listed:

Freescale Semiconductor, Inc.
Technical Information Center, EL516
2100 East Elliot Road
Tempe, Arizona 85284
+1-800-521-6274 or +1-480-768-2130
www.freescale.com/support

Europe, Middle East, and Africa:

Freescale Halbleiter Deutschland GmbH
Technical Information Center
Schatzbogen 7
81829 Muenchen, Germany
+44 1296 380 456 (English)
+46 8 52200080 (English)
+49 89 92103 559 (German)
+33 1 69 35 48 48 (French)
www.freescale.com/support

Japan:

Freescale Semiconductor Japan Ltd.
Headquarters
ARCO Tower 15F
1-8-1, Shimo-Meguro, Meguro-ku,
Tokyo 153-0064
Japan
0120 191014 or +81 3 5437 9125
support.japan@freescale.com

Asia/Pacific:

Freescale Semiconductor Hong Kong Ltd.
Technical Information Center
2 Dai King Street
Tai Po Industrial Estate
Tai Po, N.T., Hong Kong
+800 2666 8080
support.asia@freescale.com

For Literature Requests Only:

Freescale Semiconductor Literature Distribution Center
P.O. Box 5405
Denver, Colorado 80217
1-800-441-2447 or 303-675-2140
Fax: 303-675-2150
LDCForFreescaleSemiconductor@hibbertgroup.com

Information in this document is provided solely to enable system and software implementers to use Freescale Semiconductor products. There are no express or implied copyright licenses granted hereunder to design or fabricate any integrated circuits or integrated circuits based on the information in this document.

Freescale Semiconductor reserves the right to make changes without further notice to any products herein. Freescale Semiconductor makes no warranty, representation or guarantee regarding the suitability of its products for any particular purpose, nor does Freescale Semiconductor assume any liability arising out of the application or use of any product or circuit, and specifically disclaims any and all liability, including without limitation consequential or incidental damages. "Typical" parameters that may be provided in Freescale Semiconductor data sheets and/or specifications can and do vary in different applications and actual performance may vary over time. All operating parameters, including "Typicals", must be validated for each customer application by customer's technical experts. Freescale Semiconductor does not convey any license under its patent rights nor the rights of others. Freescale Semiconductor products are not designed, intended, or authorized for use as components in systems intended for surgical implant into the body, or other applications intended to support or sustain life, or for any other application in which the failure of the Freescale Semiconductor product could create a situation where personal injury or death may occur. Should Buyer purchase or use Freescale Semiconductor products for any such unintended or unauthorized application, Buyer shall indemnify and hold Freescale Semiconductor and its officers, employees, subsidiaries, affiliates, and distributors harmless against all claims, costs, damages, and expenses, and reasonable attorney fees arising out of, directly or indirectly, any claim of personal injury or death associated with such unintended or unauthorized use, even if such claim alleges that Freescale Semiconductor was negligent regarding the design or manufacture of the part.

RoHS-compliant and/or Pb-free versions of Freescale products have the functionality and electrical characteristics as their non-RoHS-compliant and/or non-Pb-free counterparts. For further information, see <http://www.freescale.com> or contact your Freescale sales representative.

For information on Freescale's Environmental Products program, go to <http://www.freescale.com/epp>.

Freescale™ and the Freescale logo are trademarks of Freescale Semiconductor, Inc. All other product or service names are the property of their respective owners.
© Freescale Semiconductor, Inc. 2009. All rights reserved.

Document Number: MC56F8006

Rev. 2

03/2009

