

The revision list can be viewed directly by clicking the title page.
The revision list summarizes the locations of revisions and additions. Details should always be checked by referring to the relevant text.

32**SH7144** Group, **SH7145** Group

Hardware Manual

Renesas 32-Bit RISC Microcomputer
SuperH™ RISC engine Family/SH7144 Series

| | |
|--------|-----------|
| SH7114 | HD64F7144 |
| | HD6437144 |
| | HD6417144 |
| SH7145 | HD64F7145 |
| | HD6437145 |
| | HD6417145 |

Hardware Manual

Notes regarding these materials

1. This document is provided for reference purposes only so that Renesas customers may select the appropriate Renesas products for their use. Renesas neither makes warranties or representations with respect to the accuracy or completeness of the information contained in this document nor grants any license to any intellectual property rights or any other rights of Renesas or any third party with respect to the information in this document.
2. Renesas shall have no liability for damages or infringement of any intellectual property or other rights arising out of the use of any information in this document, including, but not limited to, product data, diagrams, charts, programs, algorithms, and application circuit examples.
3. You should not use the products or the technology described in this document for the purpose of military applications such as the development of weapons of mass destruction or for the purpose of any other military use. When exporting the products or technology described herein, you should follow the applicable export control laws and regulations, and procedures required by such laws and regulations.
4. All information included in this document such as product data, diagrams, charts, programs, algorithms, and application circuit examples, is current as of the date this document is issued. Such information, however, is subject to change without any prior notice. Before purchasing or using any Renesas products listed in this document, please confirm the latest product information with a Renesas sales office. Also, please pay regular and careful attention to additional and different information to be disclosed by Renesas such as that disclosed through our website. (<http://www.renesas.com>)
5. Renesas has used reasonable care in compiling the information included in this document, but Renesas assumes no liability whatsoever for any damages incurred as a result of errors or omissions in the information included in this document.
6. When using or otherwise relying on the information in this document, you should evaluate the information in light of the total system before deciding about the applicability of such information to the intended application. Renesas makes no representations, warranties or guaranties regarding the suitability of its products for any particular application and specifically disclaims any liability arising out of the application and use of the information in this document or Renesas products.
7. With the exception of products specified by Renesas as suitable for automobile applications, Renesas products are not designed, manufactured or tested for applications or otherwise in systems the failure or malfunction of which may cause a direct threat to human life or create a risk of human injury or which require especially high quality and reliability such as safety systems, or equipment or systems for transportation and traffic, healthcare, combustion control, aerospace and aeronautics, nuclear power, or undersea communication transmission. If you are considering the use of our products for such purposes, please contact a Renesas sales office beforehand. Renesas shall have no liability for damages arising out of the uses set forth above.
8. Notwithstanding the preceding paragraph, you should not use Renesas products for the purposes listed below:
 - (1) artificial life support devices or systems
 - (2) surgical implantations
 - (3) healthcare intervention (e.g., excision, administration of medication, etc.)
 - (4) any other purposes that pose a direct threat to human lifeRenesas shall have no liability for damages arising out of the uses set forth in the above and purchasers who elect to use Renesas products in any of the foregoing applications shall indemnify and hold harmless Renesas Technology Corp., its affiliated companies and their officers, directors, and employees against any and all damages arising out of such applications.
9. You should use the products described herein within the range specified by Renesas, especially with respect to the maximum rating, operating supply voltage range, movement power voltage range, heat radiation characteristics, installation and other product characteristics. Renesas shall have no liability for malfunctions or damages arising out of the use of Renesas products beyond such specified ranges.
10. Although Renesas endeavors to improve the quality and reliability of its products, IC products have specific characteristics such as the occurrence of failure at a certain rate and malfunctions under certain use conditions. Please be sure to implement safety measures to guard against the possibility of physical injury, and injury or damage caused by fire in the event of the failure of a Renesas product, such as safety design for hardware and software including but not limited to redundancy, fire control and malfunction prevention, appropriate treatment for aging degradation or any other applicable measures. Among others, since the evaluation of microcomputer software alone is very difficult, please evaluate the safety of the final products or system manufactured by you.
11. In case Renesas products listed in this document are detached from the products to which the Renesas products are attached or affixed, the risk of accident such as swallowing by infants and small children is very high. You should implement safety measures so that Renesas products may not be easily detached from your products. Renesas shall have no liability for damages arising out of such detachment.
12. This document may not be reproduced or duplicated, in any form, in whole or in part, without prior written approval from Renesas.
13. Please contact a Renesas sales office if you have any questions regarding the information contained in this document, Renesas semiconductor products, or if you have any other inquiries.

General Precautions in the Handling of MPU/MCU Products

The following usage notes are applicable to all MPU/MCU products from Renesas. For detailed usage notes on the products covered by this manual, refer to the relevant sections of the manual. If the descriptions under General Precautions in the Handling of MPU/MCU Products and in the body of the manual differ from each other, the description in the body of the manual takes precedence.

1. Handling of Unused Pins

Handle unused pins in accord with the directions given under Handling of Unused Pins in the manual.

- The input pins of CMOS products are generally in the high-impedance state. In operation with an unused pin in the open-circuit state, extra electromagnetic noise is induced in the vicinity of LSI, an associated shoot-through current flows internally, and malfunctions may occur due to the false recognition of the pin state as an input signal. Unused pins should be handled as described under Handling of Unused Pins in the manual.

2. Processing at Power-on

The state of the product is undefined at the moment when power is supplied.

- The states of internal circuits in the LSI are indeterminate and the states of register settings and pins are undefined at the moment when power is supplied.

In a finished product where the reset signal is applied to the external reset pin, the states of pins are not guaranteed from the moment when power is supplied until the reset process is completed.

In a similar way, the states of pins in a product that is reset by an on-chip power-on reset function are not guaranteed from the moment when power is supplied until the power reaches the level at which resetting has been specified.

3. Prohibition of Access to Reserved Addresses

Access to reserved addresses is prohibited.

- The reserved addresses are provided for the possible future expansion of functions. Do not access these addresses; the correct operation of LSI is not guaranteed if they are accessed.

4. Clock Signals

After applying a reset, only release the reset line after the operating clock signal has become stable. When switching the clock signal during program execution, wait until the target clock signal has stabilized.

- When the clock signal is generated with an external resonator (or from an external oscillator) during a reset, ensure that the reset line is only released after full stabilization of the clock signal. Moreover, when switching to a clock signal produced with an external resonator (or by an external oscillator) while program execution is in progress, wait until the target clock signal is stable.

5. Differences between Products

Before changing from one product to another, i.e. to one with a different type number, confirm that the change will not lead to problems.

- The characteristics of MPU/MCU in the same group but having different type numbers may differ because of the differences in internal memory capacity and layout pattern. When changing to products of different type numbers, implement a system-evaluation test for each of the products.

Configuration of This Manual

This manual comprises the following items:

1. General Precautions in the Handling of MPU/MCU Products
2. Configuration of This Manual
3. Preface
4. Contents
5. Overview
6. Description of Functional Modules
 - CPU and System-Control Modules
 - On-Chip Peripheral Modules

The configuration of the functional description of each module differs according to the module. However, the generic style includes the following items:

- i) Feature
- ii) Input/Output Pin
- iii) Register Description
- iv) Operation
- v) Usage Note

When designing an application system that includes this LSI, take notes into account. Each section includes notes in relation to the descriptions given, and usage notes are given, as required, as the final part of each section.

7. List of Registers
8. Electrical Characteristics
9. Appendix
10. Main Revisions for this Edition (only for revised versions)

The list of revisions is a summary of points that have been revised or added to earlier versions. This does not include all of the revised contents. For details, see the actual locations in this manual.

11. Index

Preface

The SH7144 Group and SH7145 Group single-chip RISC (Reduced Instruction Set Computer) microcomputers integrate a Renesas Technology Corp. original RISC CPU core with peripheral functions required for system configuration.

Target users: This manual was written for users who will be using this LSI in the design of application systems. Users of this manual are expected to understand the fundamentals of electrical circuits, logical circuits, and microcomputers.

Objective: This manual was written to explain the hardware functions and electrical characteristics of this LSI to the above users.
Refer to the SH-1/SH-2/SH-DSP Software Manual for a detailed description of the instruction set.

Notes on reading this manual:

- Product names

The following products are covered in this manual.

Product Classifications and Abbreviations

| Basic Classification | On-Chip ROM Classification | Part No. | |
|--------------------------|----------------------------|---|-----------|
| SH7144 (112-pin version) | SH7144F | Flash memory version (ROM: 256 kbytes) | HD64F7144 |
| | SH7144M | Masked ROM version (ROM: 256 kbytes) | HD6437144 |
| | | ROM less version | HD6417144 |
| SH7145 (144-pin version) | SH7145F | Flash memory version (ROM: 256 kbytes) | HD64F7145 |
| | SH7145M | Masked ROM version (ROM: 256 kbytes) | HD6437145 |
| | | ROM less version | HD6417145 |

In this manual, the product abbreviations are used to distinguish products. For example, 112-pin products are collectively referred to as the SH7144, an abbreviation of the basic type's classification code, while 144-pin products are collectively referred to as the SH7145. There are three versions of each: a flash memory version, masked ROM version, and ROM less version. When a description is limited to the flash memory version alone, the character F is added at the end of the abbreviation, such as SH7144F. When a description is limited to the masked ROM version or ROM less version, the character M is added at the end of the abbreviation, such as SH7144M.

- The typical product
The HD64F7144 is taken as the typical product for the descriptions in this manual. Accordingly, when using an HD6437144, HD6417144, HD64F7145, HD6437145, or HD6417145 simply replace the HD64F7144 in those references where no differences between products are pointed out with HD6437144, HD6417144, HD64F7145, HD6437145, or HD6417145. Where differences are indicated, be aware that each specification applies to the products as indicated.
- In order to understand the overall functions of the chip
Read the manual according to the contents. This manual can be roughly categorized into parts on the CPU, system control functions, peripheral functions, and electrical characteristics.
- In order to understand the details of the CPU's functions
Read the SH-1/SH-2/SH-DSP Software Manual.
- In order to understand the details of a register when the user knows its name
Read the index that is the final part of the manual to find the page number of the entry on the register. The addresses, bit names, and initial values of the registers are summarized in section 25, List of Registers.

| | | |
|--------|-----------------------|---|
| Rules: | Register name: | The following notation is used for cases when the same or a similar function, e.g. serial communication, is implemented on more than one channel: XXX_N (XXX is the register name and N is the channel number) |
| | Bit order: | The MSB is on the left and the LSB is on the right. |
| | Numerical expression: | Binary is B'xxxx, hexadecimal is H'xxxx, and decimal is xxxx. |
| | Signal expression: | Low active signals are expressed as $\overline{\text{xxxx}}$. |

Related Manuals: The latest versions of all related manuals are available from our web site. Please ensure you have the latest versions of all documents you require.
<http://www.renesas.com/>

SH7144 Group, SH7145 Group manuals:

| Document Title | Document No. |
|--|---------------------|
| SH7144 Group, SH7145 Group Hardware Manual | This manual |
| SH-1/SH-2/SH-DSP Software Manual | REJ09B0171 |

User's manuals for development tools:

| Document Title | Document No. |
|---|---------------------|
| C/C++ Compiler, Assembler, Optimized Linkage Editor User's Manual | REJ10B0047 |
| Simulator/Debugger (for Windows) User's Manual | ADE-702-283 |
| High-performance Embedded Workshop User's Manual | REJ10J1737 |

Application Notes:

| Document Title | Document No. |
|------------------------|---------------------|
| C/C++ Compiler Edition | REJ05B0463 |

All trademarks and registered trademarks are the property of their respective owners.

Contents

| | | |
|-----------|-----------------------------------|----|
| Section 1 | Overview | 1 |
| 1.1 | Features | 2 |
| 1.2 | Internal Block Diagram | 4 |
| 1.3 | Pin Arrangement | 6 |
| 1.4 | Pin Functions | 8 |
| Section 2 | CPU | 15 |
| 2.1 | Features | 15 |
| 2.2 | Register Configuration | 15 |
| 2.2.1 | General Registers (Rn) | 15 |
| 2.2.2 | Control Registers | 17 |
| 2.2.3 | System Registers | 18 |
| 2.2.4 | Initial Values of Registers | 18 |
| 2.3 | Data Formats | 19 |
| 2.3.1 | Data Format in Registers | 19 |
| 2.3.2 | Data Formats in Memory | 19 |
| 2.3.3 | Immediate Data Format | 20 |
| 2.4 | Instruction Features | 21 |
| 2.4.1 | RISC-Type Instruction Set | 21 |
| 2.4.2 | Addressing Modes | 25 |
| 2.4.3 | Instruction Format | 29 |
| 2.5 | Instruction Set | 32 |
| 2.5.1 | Instruction Set by Classification | 32 |
| 2.6 | Processing States | 45 |
| 2.6.1 | State Transitions | 45 |
| Section 3 | MCU Operating Modes | 47 |
| 3.1 | Selection of Operating Modes | 47 |
| 3.2 | Input/Output Pins | 49 |
| 3.3 | Operating Modes | 50 |
| 3.3.1 | Mode 0 (MCU Extension Mode 0) | 50 |
| 3.3.2 | Mode 1 (MCU Extension Mode 1) | 50 |
| 3.3.3 | Mode 2 (MCU Extension Mode 2) | 50 |
| 3.3.4 | Mode 3 (Single Chip Mode) | 50 |
| 3.3.5 | Clock Mode | 50 |
| 3.4 | Address Map | 51 |
| 3.5 | Initial State in This LSI | 52 |

| | | |
|-----------|--|----|
| 3.6 | Note on Changing Operating Mode | 52 |
| | | |
| Section 4 | Clock Pulse Generator | 53 |
| 4.1 | Oscillator..... | 55 |
| 4.1.1 | Connecting Crystal Resonator | 55 |
| 4.1.2 | External Clock Input Method..... | 56 |
| 4.2 | Function for Detecting Oscillator Halt..... | 57 |
| 4.3 | Usage Notes | 58 |
| 4.3.1 | Note on Crystal Resonator | 58 |
| 4.3.2 | Notes on Board Design | 58 |
| | | |
| Section 5 | Exception Processing..... | 61 |
| 5.1 | Overview..... | 61 |
| 5.1.1 | Types of Exception Processing and Priority | 61 |
| 5.1.2 | Exception Processing Operations..... | 62 |
| 5.1.3 | Exception Processing Vector Table | 63 |
| 5.2 | Resets | 65 |
| 5.2.1 | Types of Reset | 65 |
| 5.2.2 | Power-On Reset | 65 |
| 5.2.3 | Manual Reset | 66 |
| 5.3 | Address Errors | 67 |
| 5.3.1 | Cause of Address Error Exception..... | 67 |
| 5.3.2 | Address Error Exception Processing..... | 68 |
| 5.4 | Interrupts..... | 69 |
| 5.4.1 | Interrupt Sources..... | 69 |
| 5.4.2 | Interrupt Priority Level | 70 |
| 5.4.3 | Interrupt Exception Processing | 70 |
| 5.5 | Exceptions Triggered by Instructions | 71 |
| 5.5.1 | Types of Exceptions Triggered by Instructions | 71 |
| 5.5.2 | Trap Instructions | 71 |
| 5.5.3 | Illegal Slot Instructions | 72 |
| 5.5.4 | General Illegal Instructions..... | 72 |
| 5.6 | Cases when Exception Sources Are not Accepted..... | 73 |
| 5.6.1 | Immediately after Delayed Branch Instruction | 73 |
| 5.6.2 | Immediately after Interrupt-Disabled Instruction | 73 |
| 5.7 | Stack Status after Exception Processing Ends | 74 |
| 5.8 | Usage Notes | 75 |
| 5.8.1 | Value of Stack Pointer (SP) | 75 |
| 5.8.2 | Value of Vector Base Register (VBR)..... | 75 |
| 5.8.3 | Address Errors Caused by Stacking of Address Error Exception Processing..... | 75 |

| | | |
|-----------|---|-----|
| Section 6 | Interrupt Controller (INTC) | 77 |
| 6.1 | Features | 77 |
| 6.2 | Input/Output Pins | 79 |
| 6.3 | Register Descriptions | 79 |
| 6.3.1 | Interrupt Control Register 1 (ICR1) | 80 |
| 6.3.2 | Interrupt Control Register 2 (ICR2) | 82 |
| 6.3.3 | IRQ Status Register (ISR) | 84 |
| 6.3.4 | Interrupt Priority Registers A to J (IPRA to IPRJ) | 85 |
| 6.4 | Interrupt Sources | 87 |
| 6.4.1 | External Interrupts | 87 |
| 6.4.2 | On-Chip Peripheral Module Interrupts | 88 |
| 6.4.3 | User Break Interrupt | 88 |
| 6.4.4 | H-UDI Interrupt | 89 |
| 6.5 | Interrupt Exception Processing Vectors Table | 90 |
| 6.6 | Operation | 93 |
| 6.6.1 | Interrupt Sequence | 93 |
| 6.6.2 | Stack after Interrupt Exception Processing | 95 |
| 6.7 | Interrupt Response Time | 96 |
| 6.8 | Data Transfer with Interrupt Request Signals | 98 |
| 6.8.1 | Handling Interrupt Request Signals as Sources for DTC Activating and CPU Interrupt, but Not DMAC Activating | 99 |
| 6.8.2 | Handling Interrupt Request Signals as Sources for Activating DMAC, but Not CPU Interrupt and DTC Activating | 99 |
| 6.8.3 | Handling Interrupt Request Signals as Source for DTC Activating, but Not CPU Interrupt and DMAC Activating | 99 |
| 6.8.4 | Handling Interrupt Request Signals as Source for CPU Interrupt but Not DMAC and DTC Activating | 100 |
| Section 7 | User Break Controller (UBC) | 101 |
| 7.1 | Features | 101 |
| 7.2 | Register Descriptions | 103 |
| 7.2.1 | User Break Address Register (UBAR) | 103 |
| 7.2.2 | User Break Address Mask Register (UBAMR) | 103 |
| 7.2.3 | User Break Bus Cycle Register (UBBR) | 104 |
| 7.2.4 | User Break Control Register (UBCR) | 105 |
| 7.3 | Operation | 106 |
| 7.3.1 | Flow of User Break Operation | 106 |
| 7.3.2 | Break on On-Chip Memory Instruction Fetch Cycle | 108 |
| 7.3.3 | Program Counter (PC) Values Saved | 108 |
| 7.4 | Examples of Use | 109 |

| | | |
|---|--|------------|
| 7.5 | Usage Notes | 111 |
| 7.5.1 | Simultaneous Fetching of Two Instructions | 111 |
| 7.5.2 | Instruction Fetches at Branches | 111 |
| 7.5.3 | Contention between User Break and Exception Processing | 112 |
| 7.5.4 | Break at Non-Delay Branch Instruction Jump Destination | 112 |
| 7.5.5 | Module Standby Mode Setting | 112 |
| Section 8 Data Transfer Controller (DTC) | | 113 |
| 8.1 | Features | 113 |
| 8.2 | Register Descriptions | 115 |
| 8.2.1 | DTC Mode Register (DTMR) | 116 |
| 8.2.2 | DTC Source Address Register (DTSAR) | 118 |
| 8.2.3 | DTC Destination Address Register (DTDAR) | 118 |
| 8.2.4 | DTC Initial Address Register (DTIAR) | 118 |
| 8.2.5 | DTC Transfer Count Register A (DTCRA) | 118 |
| 8.2.6 | DTC Transfer Count Register B (DTCRB) | 119 |
| 8.2.7 | DTC Enable Registers (DTER) | 119 |
| 8.2.8 | DTC Control/Status Register (DTC SR) | 120 |
| 8.2.9 | DTC Information Base Register (DTBR) | 121 |
| 8.3 | Operation | 122 |
| 8.3.1 | Activation Sources | 122 |
| 8.3.2 | Location of Register Information and DTC Vector Table | 122 |
| 8.3.3 | DTC Operation | 125 |
| 8.3.4 | Interrupt Source | 132 |
| 8.3.5 | Operation Timing | 132 |
| 8.3.6 | DTC Execution State Counts | 133 |
| 8.4 | Procedures for Using DTC | 134 |
| 8.4.1 | Activation by Interrupt | 134 |
| 8.4.2 | Activation by Software | 134 |
| 8.4.3 | DTC Use Example | 135 |
| 8.5 | Usage Notes | 136 |
| 8.5.1 | Prohibition against DMAC/DTC Register Access by DTC | 136 |
| 8.5.2 | Module Standby Mode Setting | 136 |
| 8.5.3 | On-Chip RAM | 136 |
| Section 9 Bus State Controller (BSC) | | 137 |
| 9.1 | Features | 137 |
| 9.2 | Input/Output Pins | 139 |
| 9.3 | Register Configuration | 140 |
| 9.4 | Address Map | 141 |

| | | |
|---|---|-----|
| 9.5 | Register Descriptions | 144 |
| 9.5.1 | Bus Control Register 1 (BCR1) | 144 |
| 9.5.2 | Bus Control Register 2 (BCR2) | 147 |
| 9.5.3 | Wait Control Register 1 (WCR1)..... | 152 |
| 9.5.4 | Wait Control Register 2 (WCR2)..... | 153 |
| 9.5.5 | RAM Emulation Register (RAMER)..... | 153 |
| 9.6 | Accessing External Space | 154 |
| 9.6.1 | Basic Timing..... | 154 |
| 9.6.2 | Wait State Control..... | 155 |
| 9.6.3 | \overline{CS} Assert Period Extension | 157 |
| 9.7 | Waits between Access Cycles | 158 |
| 9.7.1 | Prevention of Data Bus Conflicts..... | 158 |
| 9.7.2 | Simplification of Bus Cycle Start Detection | 160 |
| 9.8 | Bus Arbitration..... | 161 |
| 9.9 | Memory Connection Example | 163 |
| 9.10 | Access to On-chip Peripheral I/O Registers..... | 166 |
| 9.11 | Cycles of No-Bus Mastership Release | 166 |
| 9.12 | CPU Operation when Program Is Located in External Memory..... | 166 |
| Section 10 Direct Memory Access Controller (DMAC) | | 167 |
| 10.1 | Features | 167 |
| 10.2 | Input/Output Pins | 169 |
| 10.3 | Register Descriptions | 170 |
| 10.3.1 | DMA Source Address Registers_0 to 3 (SAR_0 to SAR_3) | 170 |
| 10.3.2 | DMA Destination Address Registers_0 to 3 (DAR_0 to DAR_3)..... | 171 |
| 10.3.3 | DMA Transfer Count Registers_0 to 3 (DMATCR_0 to DMATCR_3)..... | 171 |
| 10.3.4 | DMA Channel Control Registers_0 to 3 (CHCR_0 to CHCR_3)..... | 172 |
| 10.3.5 | DMAC Operation Register (DMAOR) | 178 |
| 10.4 | Operation..... | 180 |
| 10.4.1 | DMA Transfer Flow | 180 |
| 10.4.2 | DMA Transfer Requests | 182 |
| 10.4.3 | Channel Priority | 184 |
| 10.4.4 | DMA Transfer Types..... | 187 |
| 10.4.5 | Number of Bus Cycle States and \overline{DREQ} Pin Sample Timing..... | 197 |
| 10.4.6 | Source Address Reload Function | 203 |
| 10.4.7 | DMA Transfer Ending Conditions..... | 204 |
| 10.4.8 | DMAC Access from CPU | 205 |
| 10.5 | Examples of Use | 206 |
| 10.5.1 | Example of DMA Transfer between On-Chip SCI and External Memory | 206 |

| | | |
|--|--|------------|
| 10.5.2 | Example of DMA Transfer between External RAM and External Device with DACK..... | 207 |
| 10.5.3 | Example of DMA Transfer between A/D Converter and On-chip Memory (Address Reload On)..... | 208 |
| 10.5.4 | Example of DMA Transfer between External Memory and SCII Transmit Side (Indirect Address On) | 210 |
| 10.6 | Usage Notes | 211 |
| Section 11 Multi-Function Timer Pulse Unit (MTU)..... | | 213 |
| 11.1 | Features..... | 213 |
| 11.2 | Input/Output Pins..... | 217 |
| 11.3 | Register Descriptions | 218 |
| 11.3.1 | Timer Control Register (TCR)..... | 220 |
| 11.3.2 | Timer Mode Register (TMDR)..... | 224 |
| 11.3.3 | Timer I/O Control Register (TIOR)..... | 226 |
| 11.3.4 | Timer Interrupt Enable Register (TIER)..... | 244 |
| 11.3.5 | Timer Status Register (TSR)..... | 246 |
| 11.3.6 | Timer Counter (TCNT)..... | 249 |
| 11.3.7 | Timer General Register (TGR) | 249 |
| 11.3.8 | Timer Start Register (TSTR) | 250 |
| 11.3.9 | Timer Synchronous Register (TSYR)..... | 250 |
| 11.3.10 | Timer Output Master Enable Register (TOER) | 252 |
| 11.3.11 | Timer Output Control Register (TOCR)..... | 253 |
| 11.3.12 | Timer Gate Control Register (TGCR) | 255 |
| 11.3.13 | Timer Subcounter (TCNTS) | 257 |
| 11.3.14 | Timer Dead Time Data Register (TDDR)..... | 257 |
| 11.3.15 | Timer Period Data Register (TCDR) | 257 |
| 11.3.16 | Timer Period Buffer Register (TCBR)..... | 257 |
| 11.3.17 | Bus Master Interface..... | 258 |
| 11.4 | Operation | 259 |
| 11.4.1 | Basic Functions..... | 259 |
| 11.4.2 | Synchronous Operation..... | 264 |
| 11.4.3 | Buffer Operation..... | 266 |
| 11.4.4 | Cascaded Operation | 269 |
| 11.4.5 | PWM Modes..... | 271 |
| 11.4.6 | Phase Counting Mode..... | 276 |
| 11.4.7 | Reset-Synchronized PWM Mode..... | 282 |
| 11.4.8 | Complementary PWM Mode..... | 285 |
| 11.5 | Interrupt Sources..... | 310 |
| 11.5.1 | Interrupt Sources and Priorities..... | 310 |

| | | |
|---------|---|-----|
| 11.5.2 | DTC/DMAC Activation..... | 312 |
| 11.5.3 | A/D Converter Activation..... | 312 |
| 11.6 | Operation Timing..... | 313 |
| 11.6.1 | Input/Output Timing..... | 313 |
| 11.6.2 | Interrupt Signal Timing..... | 318 |
| 11.7 | Usage Notes..... | 321 |
| 11.7.1 | Module Standby Mode Setting..... | 321 |
| 11.7.2 | Input Clock Restrictions..... | 321 |
| 11.7.3 | Caution on Period Setting..... | 322 |
| 11.7.4 | Contention between TCNT Write and Clear Operations..... | 322 |
| 11.7.5 | Contention between TCNT Write and Increment Operations..... | 323 |
| 11.7.6 | Contention between TGR Write and Compare Match..... | 324 |
| 11.7.7 | Contention between Buffer Register Write and Compare Match..... | 325 |
| 11.7.8 | Contention between TGR Read and Input Capture..... | 326 |
| 11.7.9 | Contention between TGR Write and Input Capture..... | 327 |
| 11.7.10 | Contention between Buffer Register Write and Input Capture..... | 328 |
| 11.7.11 | TCNT2 Write and Overflow/Underflow Contention in Cascade Connection..... | 328 |
| 11.7.12 | Counter Value during Complementary PWM Mode Stop..... | 330 |
| 11.7.13 | Buffer Operation Setting in Complementary PWM Mode..... | 330 |
| 11.7.14 | Reset Sync PWM Mode Buffer Operation and Compare Match Flag..... | 331 |
| 11.7.15 | Overflow Flags in Reset Synchronous PWM Mode..... | 332 |
| 11.7.16 | Contention between Overflow/Underflow and Counter Clearing..... | 333 |
| 11.7.17 | Contention between TCNT Write and Overflow/Underflow..... | 334 |
| 11.7.18 | Cautions on Transition from Normal Operation or PWM Mode 1 to Reset-Synchronous PWM Mode..... | 334 |
| 11.7.19 | Output Level in Complementary PWM Mode and Reset-Synchronous PWM Mode..... | 335 |
| 11.7.20 | Interrupts in Module Standby Mode..... | 335 |
| 11.7.21 | Simultaneous Capture of TCNT_1 and TCNT_2 in Cascade Connection..... | 335 |
| 11.7.22 | Note on Buffer Operation Setting..... | 335 |
| 11.8 | MTU Output Pin Initialization..... | 336 |
| 11.8.1 | Operating Modes..... | 336 |
| 11.8.2 | Reset Start Operation..... | 336 |
| 11.8.3 | Operation in Case of Re-Setting Due to Error During Operation, Etc..... | 337 |
| 11.8.4 | Overview of Initialization Procedures and Mode Transitions in Case of Error during Operation, etc..... | 338 |
| 11.9 | Port Output Enable (POE)..... | 368 |
| 11.9.1 | Features..... | 368 |
| 11.9.2 | Pin Configuration..... | 370 |
| 11.9.3 | Register Descriptions..... | 370 |

| | | |
|--|--|------------|
| 11.9.4 | Operation | 375 |
| 11.9.5 | Usage Notes | 377 |
| Section 12 Watchdog Timer (WDT) | | 379 |
| 12.1 | Features..... | 379 |
| 12.2 | Input/Output Pin..... | 380 |
| 12.3 | Register Descriptions | 381 |
| 12.3.1 | Timer Counter (TCNT)..... | 381 |
| 12.3.2 | Timer Control/Status Register (TCSR)..... | 382 |
| 12.3.3 | Reset Control/Status Register (RSTCSR)..... | 384 |
| 12.4 | Operation | 385 |
| 12.4.1 | Watchdog Timer Mode | 385 |
| 12.4.2 | Interval Timer Mode..... | 386 |
| 12.4.3 | Clearing Software Standby Mode | 387 |
| 12.4.4 | Timing of Setting Overflow Flag (OVF)..... | 387 |
| 12.4.5 | Timing of Setting Watchdog Timer Overflow Flag (WOVF) | 388 |
| 12.5 | Interrupt Source | 388 |
| 12.6 | Usage Notes | 389 |
| 12.6.1 | Notes on Register Access..... | 389 |
| 12.6.2 | TCNT Write and Increment Contention | 390 |
| 12.6.3 | Changing CKS2 to CKS0 Bit Values | 391 |
| 12.6.4 | Changing between Watchdog Timer and Interval Timer Modes | 391 |
| 12.6.5 | System Reset by $\overline{\text{WDTOVF}}$ Signal..... | 391 |
| 12.6.6 | Internal Reset in Watchdog Timer Mode..... | 391 |
| 12.6.7 | Manual Reset in Watchdog Timer Mode..... | 392 |
| 12.6.8 | Note on Using $\overline{\text{WDTOVF}}$ Signal..... | 392 |
| Section 13 Serial Communication Interface (SCI) | | 393 |
| 13.1 | Features..... | 393 |
| 13.2 | Input/Output Pins | 395 |
| 13.3 | Register Descriptions | 396 |
| 13.3.1 | Receive Shift Register (RSR) | 398 |
| 13.3.2 | Receive Data Register (RDR)..... | 398 |
| 13.3.3 | Transmit Shift Register (TSR)..... | 398 |
| 13.3.4 | Transmit Data Register (TDR)..... | 398 |
| 13.3.5 | Serial Mode Register (SMR) | 399 |
| 13.3.6 | Serial Control Register (SCR)..... | 402 |
| 13.3.7 | Serial Status Register (SSR) | 407 |
| 13.3.8 | Serial Direction Control Register (SDCR)..... | 415 |
| 13.3.9 | Bit Rate Register (BRR) | 416 |

| | | |
|--------|--|-----|
| 13.4 | Operation in Asynchronous Mode | 426 |
| 13.4.1 | Data Transfer Format | 427 |
| 13.4.2 | Receive Data Sampling Timing and Reception Margin in Asynchronous Mode | 428 |
| 13.4.3 | Clock | 429 |
| 13.4.4 | SCI Initialization (Asynchronous Mode) | 430 |
| 13.4.5 | Data Transmission (Asynchronous Mode)..... | 431 |
| 13.4.6 | Serial Data Reception (Asynchronous Mode)..... | 433 |
| 13.5 | Multiprocessor Communication Function..... | 437 |
| 13.5.1 | Multiprocessor Serial Data Transmission | 439 |
| 13.5.2 | Multiprocessor Serial Data Reception | 440 |
| 13.6 | Operation in Clocked Synchronous Mode | 443 |
| 13.6.1 | Clock | 443 |
| 13.6.2 | SCI Initialization (Clocked Synchronous Mode) | 444 |
| 13.6.3 | Serial Data Transmission (Clocked Synchronous Mode) | 445 |
| 13.6.4 | Serial Data Reception (Clocked Synchronous Mode)..... | 447 |
| 13.6.5 | Simultaneous Serial Data Transmission and Reception (Clocked Synchronous Mode) | 449 |
| 13.7 | Smart Card Interface | 451 |
| 13.7.1 | Pin Connection Example..... | 451 |
| 13.7.2 | Data Format (Except for Block Transfer Mode)..... | 452 |
| 13.7.3 | Block Transfer Mode | 453 |
| 13.7.4 | Receive Data Sampling Timing and Reception Margin..... | 454 |
| 13.7.5 | Initialization | 455 |
| 13.7.6 | Serial Data Transmission (Except for Block Transfer Mode)..... | 456 |
| 13.7.7 | Clock Output Control..... | 459 |
| 13.8 | Interrupt Sources | 460 |
| 13.8.1 | Interrupts in Normal Serial Communication Interface Mode..... | 460 |
| 13.8.2 | Interrupts in Smart Card Interface Mode | 462 |
| 13.9 | Usage Notes | 463 |
| 13.9.1 | TDR Write and TDRE Flag | 463 |
| 13.9.2 | Module Standby Mode Setting..... | 463 |
| 13.9.3 | Break Detection and Processing (Asynchronous Mode Only)..... | 463 |
| 13.9.4 | Sending Break Signal (Asynchronous Mode Only) | 463 |
| 13.9.5 | Receive Error Flags and Transmit Operations (Clocked Synchronous Mode Only)..... | 464 |
| 13.9.6 | Notes on DMAC and DTC Use | 464 |
| 13.9.7 | Notes on Clocked Synchronous External Clock Mode | 464 |
| 13.9.8 | Note on Clocked Synchronous Internal Clock Mode..... | 465 |

| | | |
|------------|--|-----|
| Section 14 | I ² C Bus Interface (IIC) Option..... | 467 |
| 14.1 | Features..... | 468 |
| 14.2 | Input/Output Pins..... | 470 |
| 14.3 | Description of Registers..... | 471 |
| 14.3.1 | I ² C Bus Data Register (ICDR)..... | 471 |
| 14.3.2 | Slave-Address Register (SAR)..... | 472 |
| 14.3.3 | Second Slave-Address Register (SARX)..... | 473 |
| 14.3.4 | I ² C Bus Mode Register (ICMR)..... | 474 |
| 14.3.5 | I ² C Bus Control Register (ICCR)..... | 477 |
| 14.3.6 | I ² C Bus Status Register (ICSR)..... | 486 |
| 14.3.7 | Serial Control Register X (SCRX)..... | 490 |
| 14.3.8 | ICDRE Flag (Internal Flag)..... | 492 |
| 14.4 | Operation..... | 493 |
| 14.4.1 | I ² C Bus Data Formats..... | 493 |
| 14.4.2 | Initialization..... | 495 |
| 14.4.3 | Operations in Master Transmission..... | 496 |
| 14.4.4 | Operations in Master Reception..... | 501 |
| 14.4.5 | Operations in Slave Reception..... | 509 |
| 14.4.6 | Operations in Slave Transmission..... | 518 |
| 14.4.7 | Timing for Setting IRIC and the Control of SCL..... | 521 |
| 14.4.8 | DTC Operation..... | 524 |
| 14.4.9 | Noise Canceller..... | 526 |
| 14.4.10 | Initialization of Internal State..... | 526 |
| 14.5 | Usage Notes..... | 528 |
| 14.5.1 | Module Stop Mode Setting..... | 539 |
| Section 15 | A/D Converter..... | 541 |
| 15.1 | Features..... | 541 |
| 15.2 | Input/Output Pins..... | 543 |
| 15.3 | Register Descriptions..... | 544 |
| 15.3.1 | A/D Data Registers 0 to 7 (ADDR0 to ADDR7)..... | 544 |
| 15.3.2 | A/D Control/Status Register_0, 1 (ADCSR_0, ADCSR_1)..... | 545 |
| 15.3.3 | A/D Control Register_0, 1 (ADCR_0, ADCR_1)..... | 547 |
| 15.3.4 | A/D Trigger Select Register (ADTSR)..... | 548 |
| 15.4 | Operation..... | 549 |
| 15.4.1 | Single Mode..... | 549 |
| 15.4.2 | Continuous Scan Mode..... | 549 |
| 15.4.3 | Single-Cycle Scan Mode..... | 550 |
| 15.4.4 | Input Signal Sampling and A/D Conversion Time..... | 550 |
| 15.4.5 | A/D Converter Activation by MTU..... | 552 |

| | | |
|-------------------|--|------------|
| 15.4.6 | External Trigger Input Timing | 552 |
| 15.5 | Interrupt Sources and DTC, DMAC Transfer Requests..... | 553 |
| 15.6 | Definitions of A/D Conversion Accuracy | 554 |
| 15.7 | Usage Notes | 556 |
| 15.7.1 | Module Standby Mode Setting..... | 556 |
| 15.7.2 | Permissible Signal Source Impedance | 556 |
| 15.7.3 | Influences on Absolute Accuracy | 556 |
| 15.7.4 | Range of Analog Power Supply and Other Pin Settings | 557 |
| 15.7.5 | Notes on Board Design | 557 |
| 15.7.6 | Notes on Noise Countermeasures | 557 |
| Section 16 | Compare Match Timer (CMT)..... | 559 |
| 16.1 | Features | 559 |
| 16.2 | Register Descriptions | 560 |
| 16.2.1 | Compare Match Timer Start Register (CMSTR) | 560 |
| 16.2.2 | Compare Match Timer Control/Status Register_0, 1 (CMCSR_0, CMCSR_1) | 561 |
| 16.2.3 | Compare Match Timer Counter_0, 1 (CMCNT_0, CMCNT_1) | 562 |
| 16.2.4 | Compare Match Timer Constant Register_0, 1 (CMCOR_0, CMCOR_1) | 562 |
| 16.3 | Operation..... | 563 |
| 16.3.1 | Compare Match Counter Operation | 563 |
| 16.3.2 | CMCNT Count Timing..... | 563 |
| 16.4 | Interrupts | 564 |
| 16.4.1 | Interrupt Sources and DTC Activation | 564 |
| 16.4.2 | Compare Match Flag Set Timing..... | 564 |
| 16.4.3 | Compare Match Flag Clear Timing | 565 |
| 16.5 | Usage Notes | 566 |
| 16.5.1 | Contention between CMCNT Write and Compare Match..... | 566 |
| 16.5.2 | Contention between CMCNT Word Write and Counter Incrementation..... | 567 |
| 16.5.3 | Contention between CMCNT Byte Write and Counter Incrementation | 568 |
| Section 17 | Pin Function Controller (PFC)..... | 569 |
| 17.1 | Register Descriptions | 595 |
| 17.1.1 | Port A I/O Register L, H (PAIORL, PAIORH) | 596 |
| 17.1.2 | Port A Control Registers L2, L1, H (PACRL2, PACRL1, PACRH)..... | 597 |
| 17.1.3 | Port B I/O Register (PBIOR) | 605 |
| 17.1.4 | Port B Control Registers 1, 2 (PBCR1, PBCR2) | 605 |
| 17.1.5 | Port C I/O Register (PCIOR) | 609 |
| 17.1.6 | Port C Control Register (PCCR)..... | 609 |
| 17.1.7 | Port D I/O Registers L, H (PDIORL, PDIORH)..... | 611 |

| | | |
|--|--|------------|
| 17.1.8 | Port D Control Registers L1, L2, H1, H2 (PDCRL1, PDCRL2, PDCRH1, PDCRH2)..... | 612 |
| 17.1.9 | Port E I/O Register L (PEIORL)..... | 621 |
| 17.1.10 | Port E Control Registers L1, L2 (PECRL1, PECRL2)..... | 622 |
| 17.1.11 | High-Current Port Control Register (PPCR)..... | 630 |
| 17.2 | Usage Notes | 631 |
| Section 18 I/O Ports..... | | 633 |
| 18.1 | Port A..... | 634 |
| 18.1.1 | Register Descriptions..... | 636 |
| 18.1.2 | Port A Data Registers H and L (PADRH and PADRL)..... | 636 |
| 18.2 | Port B..... | 639 |
| 18.2.1 | Register Descriptions..... | 639 |
| 18.2.2 | Port B Data Register (PBDR) | 640 |
| 18.3 | Port C..... | 642 |
| 18.3.1 | Register Descriptions..... | 642 |
| 18.3.2 | Port C Data Register (PCDR) | 643 |
| 18.4 | Port D..... | 645 |
| 18.4.1 | Register Descriptions..... | 647 |
| 18.4.2 | Port D Data Registers H and L (PDDRH and PDDRL)..... | 647 |
| 18.5 | Port E..... | 650 |
| 18.5.1 | Register Descriptions..... | 651 |
| 18.5.2 | Port E Data Register L (PEDRL)..... | 652 |
| 18.6 | Port F..... | 654 |
| 18.6.1 | Register Descriptions..... | 654 |
| 18.6.2 | Port F Data Register (PFDR) | 654 |
| Section 19 Flash Memory (F-ZTAT Version)..... | | 657 |
| 19.1 | Features..... | 657 |
| 19.2 | Mode Transitions | 659 |
| 19.3 | Block Configuration..... | 663 |
| 19.4 | Input/Output Pins | 664 |
| 19.5 | Register Descriptions..... | 665 |
| 19.5.1 | Flash Memory Control Register 1 (FLMCR1)..... | 665 |
| 19.5.2 | Flash Memory Control Register 2 (FLMCR2)..... | 666 |
| 19.5.3 | Erase Block Register 1 (EBR1) | 667 |
| 19.5.4 | Erase Block Register 2 (EBR2) | 668 |
| 19.5.5 | RAM Emulation Register (RAMER)..... | 668 |
| 19.6 | On-Board Programming Modes..... | 670 |
| 19.6.1 | Boot Mode | 671 |

| | | |
|-------------------|--|------------|
| 19.6.2 | Programming/Erasing in User Program Mode..... | 673 |
| 19.7 | Flash Memory Emulation in RAM..... | 674 |
| 19.8 | Flash Memory Programming/Erasing..... | 676 |
| 19.8.1 | Program/Program-Verify Mode..... | 676 |
| 19.8.2 | Erase/Erase-Verify Mode..... | 678 |
| 19.8.3 | Interrupt Handling when Programming/Erasing Flash Memory..... | 678 |
| 19.9 | Program/Erase Protection..... | 680 |
| 19.9.1 | Hardware Protection..... | 680 |
| 19.9.2 | Software Protection..... | 681 |
| 19.9.3 | Error Protection..... | 681 |
| 19.10 | PROM Programmer Mode..... | 682 |
| 19.11 | Usage Note..... | 682 |
| 19.11.1 | Module Standby Mode Setting..... | 682 |
| 19.11.2 | Notes when Converting the F-ZTAT Versions to the Masked-ROM Versions..... | 682 |
| 19.11.3 | Notes on Flash Memory Programming and Erasing..... | 683 |
| Section 20 | Mask ROM..... | 689 |
| 20.1 | Usage Note..... | 689 |
| Section 21 | RAM..... | 691 |
| 21.1 | Usage Note..... | 691 |
| Section 22 | User Debugging Interface (H-UDI)..... | 693 |
| 22.1 | Overview..... | 693 |
| 22.1.1 | Features..... | 693 |
| 22.1.2 | Block Diagram..... | 694 |
| 22.2 | Input/Output Pins..... | 695 |
| 22.3 | Register Description..... | 696 |
| 22.3.1 | Instruction Register (SDIR)..... | 697 |
| 22.3.2 | Status Register (SDSR)..... | 698 |
| 22.3.3 | Data Register (SDDR)..... | 699 |
| 22.3.4 | Bypass Register (SDBPR)..... | 699 |
| 22.4 | Operation..... | 700 |
| 22.4.1 | H-UDI Interrupt..... | 700 |
| 22.4.2 | Bypass Mode..... | 703 |
| 22.4.3 | H-UDI Reset..... | 703 |
| 22.5 | Usage Notes..... | 704 |

| | | |
|------------|--|-----|
| Section 23 | Advanced User Debugger (AUD) | 705 |
| 23.1 | Overview | 705 |
| 23.1.1 | Features | 705 |
| 23.1.2 | Block Diagram | 706 |
| 23.2 | Input/Output Pins | 707 |
| 23.2.1 | Pin Descriptions | 707 |
| 23.3 | Branch Trace Mode | 710 |
| 23.3.1 | Overview | 710 |
| 23.3.2 | Operation | 710 |
| 23.4 | RAM Monitor Mode | 712 |
| 23.4.1 | Overview | 712 |
| 23.4.2 | Communication Protocol | 712 |
| 23.4.3 | Operation | 713 |
| 23.5 | Usage Notes | 715 |
| 23.5.1 | Initialization | 715 |
| 23.5.2 | Operation in Software Standby Mode | 715 |
| 23.5.3 | Setting the PA15/CK pin | 715 |
| 23.5.4 | Pin States | 716 |
| 23.5.5 | AUD Start-up Sequence | 716 |
| 23.5.6 | RAM Monitor Operation Using the PD22/AUDCK Pin | 716 |
| 23.5.7 | Settings of AUD-Related Pins when Using E10A | 717 |
| Section 24 | Power-Down Modes | 719 |
| 24.1 | Input/Output Pins | 721 |
| 24.2 | Register Descriptions | 721 |
| 24.2.1 | Standby Control Register (SBYCR) | 722 |
| 24.2.2 | System Control Register (SYSCR) | 724 |
| 24.2.3 | Module Standby Control Register 1 and 2 (MSTCR1 and MSTCR2) | 725 |
| 24.3 | Operation | 727 |
| 24.3.1 | Sleep Mode | 727 |
| 24.3.2 | Software Standby Mode | 728 |
| 24.3.3 | Module Standby Mode | 730 |
| 24.4 | Usage Notes | 731 |
| 24.4.1 | I/O Port Status | 731 |
| 24.4.2 | Current Consumption during Oscillation Stabilization Wait Period | 731 |
| 24.4.3 | On-Chip Peripheral Module Interrupt | 731 |
| 24.4.4 | Writing to MSTCR1 and MSTCR2 | 731 |
| 24.4.5 | DMAC, DTC, or AUD Operation in Sleep Mode | 731 |

| | | |
|---------------------------------|---|-----|
| Section 25 | List of Registers | 733 |
| 25.1 | Register Address Table (In the Order from Lower Addresses)..... | 734 |
| 25.2 | Register Bit List | 745 |
| 25.3 | Register States in Each Operating Mode..... | 758 |
| Section 26 | Electrical Characteristics | 767 |
| 26.1 | Absolute Maximum Ratings | 767 |
| 26.2 | DC Characteristics | 768 |
| 26.3 | AC Characteristics | 771 |
| 26.3.1 | Test conditions for the AC characteristics | 771 |
| 26.3.2 | Clock timing | 772 |
| 26.3.3 | Control Signal Timing | 774 |
| 26.3.4 | Bus Timing | 777 |
| 26.3.5 | Direct Memory Access Controller (DMAC) Timing | 781 |
| 26.3.6 | Multi-Function Timer Pulse Unit (MTU)Timing..... | 783 |
| 26.3.7 | I/O Port Timing..... | 784 |
| 26.3.8 | Watchdog Timer (WDT)Timing..... | 785 |
| 26.3.9 | Serial Communication Interface (SCI) Timing | 786 |
| 26.3.10 | I ² C Bus Interface Timing | 788 |
| 26.3.11 | Port Output Enable (POE) Timing..... | 789 |
| 26.3.12 | A/D Converter Timing | 790 |
| 26.3.13 | H-UDI Timing | 791 |
| 26.3.14 | AUD Timing | 793 |
| 26.4 | A/D Converter Characteristics | 795 |
| 26.5 | Flash Memory Characteristics..... | 796 |
| Appendix A | Pin States | 799 |
| A. | Pin State | 799 |
| Appendix B | Pin States of Bus Related Signals..... | 809 |
| B. | Pin States of Bus Related Signals | 809 |
| Appendix C | Product Code Lineup..... | 812 |
| Appendix D | I/O Port Block Diagrams..... | 813 |
| Appendix E | Package Dimensions..... | 870 |
| Main Revisions for this Edition | | 873 |

Figures

Section 1 Overview

| | | |
|------------|---------------------------------------|---|
| Figure 1.1 | Internal Block Diagram of SH7144..... | 4 |
| Figure 1.2 | Block Diagram of SH7145 | 5 |
| Figure 1.3 | SH7144 Pin Arrangement..... | 6 |
| Figure 1.4 | SH7145 Pin Arrangement..... | 7 |

Section 2 CPU

| | | |
|------------|---|----|
| Figure 2.1 | CPU Internal Registers | 16 |
| Figure 2.2 | Data Format in Registers | 19 |
| Figure 2.3 | Data Formats in Memory..... | 19 |
| Figure 2.4 | Transitions between Processing States | 45 |

Section 3 MCU Operating Modes

| | | |
|------------|--|----|
| Figure 3.1 | Address Map for Each Operating Mode..... | 51 |
| Figure 3.2 | Reset Input Timing when Changing Operating Mode..... | 52 |

Section 4 Clock Pulse Generator

| | | |
|------------|---|----|
| Figure 4.1 | Block Diagram of Clock Pulse Generator | 53 |
| Figure 4.2 | Connection of Crystal Resonator (Example)..... | 55 |
| Figure 4.3 | Crystal Resonator Equivalent Circuit | 55 |
| Figure 4.4 | Example of External Clock Connection | 56 |
| Figure 4.5 | Cautions for Oscillator Circuit Board Design..... | 58 |
| Figure 4.6 | Recommended External Circuitry around PLL | 59 |

Section 6 Interrupt Controller (INTC)

| | | |
|------------|--|----|
| Figure 6.1 | INTC Block Diagram | 78 |
| Figure 6.2 | Block Diagram of IRQ7 to IRQ0 Interrupts Control..... | 88 |
| Figure 6.3 | Interrupt Sequence Flowchart..... | 94 |
| Figure 6.4 | Stack after Interrupt Exception Processing..... | 95 |
| Figure 6.5 | Example of Pipeline Operation when IRQ Interrupt Is Accepted | 97 |
| Figure 6.6 | Interrupt Control Block Diagram | 98 |

Section 7 User Break Controller (UBC)

| | | |
|------------|--|-----|
| Figure 7.1 | User Break Controller Block Diagram | 102 |
| Figure 7.2 | Break Condition Determination Method | 107 |

Section 8 Data Transfer Controller (DTC)

| | | |
|------------|--|-----|
| Figure 8.1 | Block Diagram of DTC | 114 |
| Figure 8.2 | Activating Source Control Block Diagram..... | 122 |
| Figure 8.3 | DTC Register Information Allocation in Memory Space..... | 123 |
| Figure 8.4 | Correspondence between DTC Vector Address and Transfer Information | 123 |

| | | |
|-------------|--|-----|
| Figure 8.5 | DTC Operation Flowchart..... | 126 |
| Figure 8.6 | Memory Mapping in Normal Mode | 127 |
| Figure 8.7 | Memory Mapping in Repeat Mode | 128 |
| Figure 8.8 | Memory Mapping in Block Transfer Mode..... | 130 |
| Figure 8.9 | Chain Transfer..... | 131 |
| Figure 8.10 | DTC Operation Timing Example (Normal Mode) | 132 |

Section 9 Bus State Controller (BSC)

| | | |
|-------------|--|-----|
| Figure 9.1 | BSC Block Diagram..... | 138 |
| Figure 9.2 | Address Format | 141 |
| Figure 9.3 | Basic Timing of External Space Access..... | 154 |
| Figure 9.4 | Wait State Timing of External Space Access (Software Wait Only) | 155 |
| Figure 9.5 | Wait State Timing of External Space Access (Two Software Wait States + $\overline{\text{WAIT}}$ Signal Wait State)..... | 156 |
| Figure 9.6 | $\overline{\text{CS}}$ Assert Period Extension Function | 157 |
| Figure 9.7 | Example of Idle Cycle Insertion..... | 159 |
| Figure 9.8 | Example of Idle Cycle Insertion at Same Space Consecutive Access..... | 160 |
| Figure 9.9 | Bus Mastership Release Procedure..... | 162 |
| Figure 9.10 | Example of 8-bit Data Bus Width ROM Connection | 163 |
| Figure 9.11 | Example of 16-bit Data Bus Width ROM Connection | 163 |
| Figure 9.12 | Example of 32-bit Data Bus Width ROM Connection (only for SH7145)..... | 164 |
| Figure 9.13 | Example of 8-bit Data Bus Width SRAM Connection..... | 164 |
| Figure 9.14 | Example of 16-bit Data Bus Width SRAM Connection..... | 165 |
| Figure 9.15 | Example of 32-bit Data Bus Width SRAM Connection (only for SH7145)..... | 165 |
| Figure 9.16 | One Bus Cycle..... | 166 |

Section 10 Direct Memory Access Controller (DMAC)

| | | |
|-----------------|---|-----|
| Figure 10.1 | DMAC Block Diagram..... | 168 |
| Figure 10.2 | DMAC Transfer Flowchart | 181 |
| Figure 10.3 (1) | Round Robin Mode..... | 185 |
| Figure 10.3 (2) | Example of Changes in Priority in Round Robin Mode | 186 |
| Figure 10.4 | Data Flow in Single Address Mode..... | 188 |
| Figure 10.5 | Example of DMA Transfer Timing in Single Address Mode..... | 189 |
| Figure 10.6 | Direct Address Operation during Dual Address Mode..... | 190 |
| Figure 10.7 | Example of Direct Address Transfer Timing in Dual Address Mode | 191 |
| Figure 10.8 | Dual Address Mode and Indirect Address Operation (When External Memory Space Is 16 Bits)..... | 192 |
| Figure 10.9 | Dual Address Mode and Indirect Address Transfer Timing Example (External Memory Space to External Memory Space, 16-Bit Width)..... | 193 |
| Figure 10.10 | Dual Address Mode and Indirect Address Transfer Timing Example (On-chip Memory Space to On-chip Memory Space)..... | 194 |

| | | |
|--------------|--|-----|
| Figure 10.11 | DMA Transfer Example in Cycle-Steal Mode | 195 |
| Figure 10.12 | DMA Transfer Example in Burst Mode | 195 |
| Figure 10.13 | Bus Handling when Multiple Channels Are Operating | 197 |
| Figure 10.14 | Cycle Steal, Dual Address and Level Detection (Fastest Operation) | 200 |
| Figure 10.15 | Cycle Steal, Dual Address and Level Detection (Normal Operation) | 200 |
| Figure 10.16 | Cycle Steal, Single Address and Level Detection (Fastest Operation)..... | 200 |
| Figure 10.17 | Cycle Steal, Single Address and Level Detection (Normal Operation)..... | 200 |
| Figure 10.18 | Burst Mode, Dual Address and Level Detection (Fastest Operation)..... | 201 |
| Figure 10.19 | Burst Mode, Dual Address and Level Detection (Normal Operation)..... | 201 |
| Figure 10.20 | Burst Mode, Single Address and Level Detection (Fastest Operation) | 201 |
| Figure 10.21 | Burst Mode, Single Address and Level Detection (Normal Operation) | 202 |
| Figure 10.22 | Burst Mode, Dual Address and Edge Detection | 202 |
| Figure 10.23 | Burst Mode, Single Address and Edge Detection..... | 202 |
| Figure 10.24 | Source Address Reload Function..... | 203 |
| Figure 10.25 | Source Address Reload Function Timing Chart..... | 203 |

Section 11 Multi-Function Timer Pulse Unit (MTU)

| | | |
|--------------|--|-----|
| Figure 11.1 | Block Diagram of MTU | 216 |
| Figure 11.2 | Complementary PWM Mode Output Level Example | 254 |
| Figure 11.3 | Example of Counter Operation Setting Procedure | 259 |
| Figure 11.4 | Free-Running Counter Operation | 260 |
| Figure 11.5 | Periodic Counter Operation | 261 |
| Figure 11.6 | Example of Setting Procedure for Waveform Output by Compare Match..... | 261 |
| Figure 11.7 | Example of 0 Output/1 Output Operation..... | 262 |
| Figure 11.8 | Example of Toggle Output Operation | 262 |
| Figure 11.9 | Example of Input Capture Operation Setting Procedure | 263 |
| Figure 11.10 | Example of Input Capture Operation..... | 264 |
| Figure 11.11 | Example of Synchronous Operation Setting Procedure..... | 265 |
| Figure 11.12 | Example of Synchronous Operation..... | 266 |
| Figure 11.13 | Compare Match Buffer Operation | 267 |
| Figure 11.14 | Input Capture Buffer Operation..... | 267 |
| Figure 11.15 | Example of Buffer Operation Setting Procedure | 267 |
| Figure 11.16 | Example of Buffer Operation (1)..... | 268 |
| Figure 11.17 | Example of Buffer Operation (2)..... | 269 |
| Figure 11.18 | Cascaded Operation Setting Procedure | 270 |
| Figure 11.19 | Example of Cascaded Operation | 270 |
| Figure 11.20 | Example of PWM Mode Setting Procedure | 273 |
| Figure 11.21 | Example of PWM Mode Operation (1) | 273 |
| Figure 11.22 | Example of PWM Mode Operation (2) | 274 |
| Figure 11.23 | Example of PWM Mode Operation (3) | 275 |
| Figure 11.24 | Example of Phase Counting Mode Setting Procedure..... | 276 |

| | | |
|--------------|--|-----|
| Figure 11.25 | Example of Phase Counting Mode 1 Operation | 277 |
| Figure 11.26 | Example of Phase Counting Mode 2 Operation | 278 |
| Figure 11.27 | Example of Phase Counting Mode 3 Operation | 279 |
| Figure 11.28 | Example of Phase Counting Mode 4 Operation | 280 |
| Figure 11.29 | Phase Counting Mode Application Example..... | 281 |
| Figure 11.30 | Procedure for Selecting Reset-Synchronized PWM Mode..... | 283 |
| Figure 11.31 | Reset-Synchronized PWM Mode Operation Example (When TOCR's OLSN = 1 and OLSP = 1) | 284 |
| Figure 11.32 | Block Diagram of Channels 3 and 4 in Complementary PWM Mode | 287 |
| Figure 11.33 | Example of Complementary PWM Mode Setting Procedure..... | 288 |
| Figure 11.34 | Complementary PWM Mode Counter Operation..... | 290 |
| Figure 11.35 | Example of Complementary PWM Mode Operation | 292 |
| Figure 11.36 | Example of PWM Cycle Updating..... | 294 |
| Figure 11.37 | Example of Data Update in Complementary PWM Mode | 296 |
| Figure 11.38 | Example of Initial Output in Complementary PWM Mode (1)..... | 297 |
| Figure 11.39 | Example of Initial Output in Complementary PWM Mode (2)..... | 298 |
| Figure 11.40 | Example of Complementary PWM Mode Waveform Output (1) | 300 |
| Figure 11.41 | Example of Complementary PWM Mode Waveform Output (2) | 300 |
| Figure 11.42 | Example of Complementary PWM Mode Waveform Output (3) | 301 |
| Figure 11.43 | Example of Complementary PWM Mode 0% and 100% Waveform Output (1) | 301 |
| Figure 11.44 | Example of Complementary PWM Mode 0% and 100% Waveform Output (2) | 302 |
| Figure 11.45 | Example of Complementary PWM Mode 0% and 100% Waveform Output (3) | 302 |
| Figure 11.46 | Example of Complementary PWM Mode 0% and 100% Waveform Output (4) | 303 |
| Figure 11.47 | Example of Complementary PWM Mode 0% and 100% Waveform Output (5) | 303 |
| Figure 11.48 | Example of Toggle Output Waveform Synchronized with PWM Output..... | 304 |
| Figure 11.49 | Counter Clearing Synchronized with Another Channel | 305 |
| Figure 11.50 | Example of Output Phase Switching by External Input (1)..... | 306 |
| Figure 11.51 | Example of Output Phase Switching by External Input (2)..... | 307 |
| Figure 11.52 | Example of Output Phase Switching by Means of UF, VF, WF Bit Settings (1) | 307 |
| Figure 11.53 | Example of Output Phase Switching by Means of UF, VF, WF Bit Settings (2) | 308 |
| Figure 11.54 | Count Timing in Internal Clock Operation..... | 313 |
| Figure 11.55 | Count Timing in External Clock Operation..... | 313 |
| Figure 11.56 | Count Timing in External Clock Operation (Phase Counting Mode)..... | 313 |

| | | |
|--------------|--|-----|
| Figure 11.57 | Output Compare Output Timing (Normal Mode/PWM Mode)..... | 314 |
| Figure 11.58 | Output Compare Output Timing (Complementary PWM Mode/ Reset Synchronous PWM Mode) | 315 |
| Figure 11.59 | Input Capture Input Signal Timing..... | 315 |
| Figure 11.60 | Counter Clear Timing (Compare Match)..... | 316 |
| Figure 11.61 | Counter Clear Timing (Input Capture) | 316 |
| Figure 11.62 | Buffer Operation Timing (Compare Match)..... | 317 |
| Figure 11.63 | Buffer Operation Timing (Input Capture) | 317 |
| Figure 11.64 | TGI Interrupt Timing (Compare Match) | 318 |
| Figure 11.65 | TGI Interrupt Timing (Input Capture) | 318 |
| Figure 11.66 | TCIV Interrupt Setting Timing..... | 319 |
| Figure 11.67 | TCIU Interrupt Setting Timing | 319 |
| Figure 11.68 | Timing for Status Flag Clearing by CPU..... | 320 |
| Figure 11.69 | Timing for Status Flag Clearing by DTC/DMAC Activation..... | 320 |
| Figure 11.70 | Phase Difference, Overlap, and Pulse Width in Phase Counting Mode | 321 |
| Figure 11.71 | Contention between TCNT Write and Clear Operations | 322 |
| Figure 11.72 | Contention between TCNT Write and Increment Operations | 323 |
| Figure 11.73 | Contention between TGR Write and Compare Match..... | 324 |
| Figure 11.74 | Contention between Buffer Register Write and Compare Match (Channel 0) | 325 |
| Figure 11.75 | Contention between Buffer Register Write and Compare Match (Channels 3 and 4)..... | 326 |
| Figure 11.76 | Contention between TGR Read and Input Capture | 326 |
| Figure 11.77 | Contention between TGR Write and Input Capture | 327 |
| Figure 11.78 | Contention between Buffer Register Write and Input Capture..... | 328 |
| Figure 11.79 | TCNT_2 Write and Overflow/Underflow Contention with Cascade Connection..... | 329 |
| Figure 11.80 | Counter Value during Complementary PWM Mode Stop..... | 330 |
| Figure 11.81 | Buffer Operation and Compare-Match Flags in Reset Synchronous PWM Mode..... | 331 |
| Figure 11.82 | Reset Synchronous PWM Mode Overflow Flag | 332 |
| Figure 11.83 | Contention between Overflow and Counter Clearing..... | 333 |
| Figure 11.84 | Contention between TCNT Write and Overflow..... | 334 |
| Figure 11.85 | Error Occurrence in Normal Mode, Recovery in Normal Mode | 339 |
| Figure 11.86 | Error Occurrence in Normal Mode, Recovery in PWM Mode 1 | 340 |
| Figure 11.87 | Error Occurrence in Normal Mode, Recovery in PWM Mode 2..... | 341 |
| Figure 11.88 | Error Occurrence in Normal Mode, Recovery in Phase Counting Mode | 342 |
| Figure 11.89 | Error Occurrence in Normal Mode, Recovery in Complementary PWM Mode..... | 343 |
| Figure 11.90 | Error Occurrence in Normal Mode, Recovery in Reset-Synchronous PWM Mode..... | 344 |

| | | |
|---------------|--|-----|
| Figure 11.91 | Error Occurrence in PWM Mode 1, Recovery in Normal Mode..... | 345 |
| Figure 11.92 | Error Occurrence in PWM Mode 1, Recovery in PWM Mode 1 | 346 |
| Figure 11.93 | Error Occurrence in PWM Mode 1, Recovery in PWM Mode 2 | 347 |
| Figure 11.94 | Error Occurrence in PWM Mode 1, Recovery in Phase Counting Mode..... | 348 |
| Figure 11.95 | Error Occurrence in PWM Mode 1, Recovery in Complementary PWM Mode | 349 |
| Figure 11.96 | Error Occurrence in PWM Mode 1, Recovery in Reset-Synchronous PWM Mode | 350 |
| Figure 11.97 | Error Occurrence in PWM Mode 2, Recovery in Normal Mode..... | 351 |
| Figure 11.98 | Error Occurrence in PWM Mode 2, Recovery in PWM Mode 1 | 352 |
| Figure 11.99 | Error Occurrence in PWM Mode 2, Recovery in PWM Mode 2 | 353 |
| Figure 11.100 | Error Occurrence in PWM Mode 2, Recovery in Phase Counting Mode..... | 354 |
| Figure 11.101 | Error Occurrence in Phase Counting Mode, Recovery in Normal Mode | 355 |
| Figure 11.102 | Error Occurrence in Phase Counting Mode, Recovery in PWM Mode 1 | 356 |
| Figure 11.103 | Error Occurrence in Phase Counting Mode, Recovery in PWM Mode 2..... | 357 |
| Figure 11.104 | Error Occurrence in Phase Counting Mode, Recovery in Phase Counting Mode | 358 |
| Figure 11.105 | Error Occurrence in Complementary PWM Mode, Recovery in Normal Mode | 359 |
| Figure 11.106 | Error Occurrence in Complementary PWM Mode, Recovery in PWM Mode 1 | 360 |
| Figure 11.107 | Error Occurrence in Complementary PWM Mode, Recovery in Complementary PWM Mode | 361 |
| Figure 11.108 | Error Occurrence in Complementary PWM Mode, Recovery in Complementary PWM Mode | 362 |
| Figure 11.109 | Error Occurrence in Complementary PWM Mode, Recovery in Reset-Synchronous PWM Mode..... | 363 |
| Figure 11.110 | Error Occurrence in Reset-Synchronous PWM Mode, Recovery in Normal Mode | 364 |
| Figure 11.111 | Error Occurrence in Reset-Synchronous PWM Mode, Recovery in PWM Mode 1 | 365 |
| Figure 11.112 | Error Occurrence in Reset-Synchronous PWM Mode, Recovery in Complementary PWM Mode | 366 |
| Figure 11.113 | Error Occurrence in Reset-Synchronous PWM Mode, Recovery in Reset-Synchronous PWM Mode..... | 367 |
| Figure 11.114 | POE Block Diagram | 369 |
| Figure 11.115 | Low-Level Detection Operation..... | 376 |
| Figure 11.116 | Output-Level Detection Operation | 376 |
| Figure 11.117 | Falling Edge Detection Operation | 377 |

Section 12 Watchdog Timer (WDT)

| | | |
|-------------|---|-----|
| Figure 12.1 | Block Diagram of WDT | 380 |
| Figure 12.2 | Operation in Watchdog Timer Mode..... | 386 |
| Figure 12.3 | Operation in Interval Timer Mode..... | 386 |
| Figure 12.4 | Timing of Setting OVF..... | 387 |
| Figure 12.5 | Timing of Setting WOVF..... | 388 |
| Figure 12.6 | Writing to TCNT and TCSR | 389 |
| Figure 12.7 | Writing to RSTCSR..... | 390 |
| Figure 12.8 | Contention between TCNT Write and Increment..... | 390 |
| Figure 12.9 | Example of System Reset Circuit Using $\overline{\text{WDTOVF}}$ Signal | 391 |

Section 13 Serial Communication Interface (SCI)

| | | |
|--------------|---|-----|
| Figure 13.1 | Block Diagram of SCI..... | 394 |
| Figure 13.2 | Data Format in Asynchronous Communication (Example with 8-Bit Data, Parity, Two Stop Bits) | 426 |
| Figure 13.3 | Receive Data Sampling Timing in Asynchronous Mode | 428 |
| Figure 13.4 | Relation between Output Clock and Transmit Data Phase (Asynchronous Mode) | 429 |
| Figure 13.5 | Sample SCI Initialization Flowchart | 430 |
| Figure 13.6 | Example of Operation in Transmission in Asynchronous Mode (Example with 8-Bit Data, Parity, One Stop Bit)..... | 431 |
| Figure 13.7 | Sample Serial Transmission Flowchart | 432 |
| Figure 13.8 | Example of SCI Operation in Reception (Example with 8-Bit Data, Parity, One Stop Bit) | 433 |
| Figure 13.9 | Sample Serial Reception Data Flowchart (1) | 435 |
| Figure 13.9 | Sample Serial Reception Data Flowchart (2) | 436 |
| Figure 13.10 | Example of Communication Using Multiprocessor Format (Transmission of Data H'AA to Receiving Station A) | 438 |
| Figure 13.11 | Sample Multiprocessor Serial Transmission Flowchart | 439 |
| Figure 13.12 | Example of SCI Operation in Reception (Example with 8-Bit Data, Multiprocessor Bit, One Stop Bit) | 440 |
| Figure 13.13 | Sample Multiprocessor Serial Reception Flowchart (1)..... | 441 |
| Figure 13.13 | Sample Multiprocessor Serial Reception Flowchart (2)..... | 442 |
| Figure 13.14 | Data Format in Clocked Synchronous Communication (For LSB-First) | 443 |
| Figure 13.15 | Sample SCI Initialization Flowchart | 444 |
| Figure 13.16 | Sample SCI Transmission Operation in Clocked Synchronous Mode | 446 |
| Figure 13.17 | Sample Serial Transmission Flowchart | 446 |
| Figure 13.18 | Example of SCI Operation in Reception | 447 |
| Figure 13.19 | Sample Serial Reception Flowchart..... | 448 |
| Figure 13.20 | Sample Flowchart of Simultaneous Serial Transmit and Receive Operations..... | 450 |
| Figure 13.21 | Example of Pin Connections for Smart Card Interface | 451 |

| | | |
|--------------|---|-----|
| Figure 13.22 | Normal Smart Card Interface Data Format | 452 |
| Figure 13.23 | Direct Convention (DIR = SINV = O/\overline{E} = 0)..... | 452 |
| Figure 13.24 | Inverse Convention (DIR = SINV = O/\overline{E} = 1)..... | 453 |
| Figure 13.25 | Receive Data Sampling Timing in Smart Card Interface Mode (Using Clock of 372 Times Bit Rate)..... | 454 |
| Figure 13.26 | Retransfer Operation in SCI Transmit Mode..... | 457 |
| Figure 13.27 | TEND Flag Generation Timing in Transmit Operation..... | 457 |
| Figure 13.28 | Example of Transmit Processing Flow..... | 458 |
| Figure 13.29 | Timing for Fixing Clock Output Level..... | 459 |
| Figure 13.30 | Example of Clocked Synchronous Transmission with DMAC/DTC | 464 |

Section 14 I²C Bus Interface (IIC) Option

| | | |
|--------------|---|-----|
| Figure 14.1 | A Block Diagram of the I ² C Bus Interface | 469 |
| Figure 14.2 | Example of the Connection of I ² C Bus Interfaces (This LSI Is the Master Device)..... | 470 |
| Figure 14.3 | I ² C Bus Data Format (I ² C Bus Format) | 493 |
| Figure 14.4 | I ² C Bus Data Format (Serial Format) | 493 |
| Figure 14.5 | I ² C Bus Timing | 494 |
| Figure 14.6 | An Example of IIC Initialization Flowchart..... | 495 |
| Figure 14.7 | Example: Flowchart of Operations in the Master Transmit Mode | 497 |
| Figure 14.8 | An Example of the Timing of Operations in Master Transmit Mode (MLS = WAIT = 0) | 499 |
| Figure 14.9 | An Example of the Stop Condition Issuance Timing in Master Transmit Mode (MLS = WAIT = 0) | 500 |
| Figure 14.10 | Example: Flowchart of Operations in the Master Receive Mode (HNDS = 1) | 502 |
| Figure 14.11 | An Example of the Timing of Operations in Master Receive Mode (MLS = WAIT = 0, HNDS = 1) | 504 |
| Figure 14.12 | An Example of the Stop Condition Issuance Timing in Master Receive Mode (MLS = WAIT = 0, HNDS = 1) | 504 |
| Figure 14.13 | Example: Flowchart of Operations in Master Receive Mode (Multiple Bytes Reception) (WAIT = 1) | 505 |
| Figure 14.14 | Example: Flowchart of Operations in Master Receive Mode (One Byte Reception) (WAIT = 1)..... | 506 |
| Figure 14.15 | An Example of the Timing of Operations in Master Receive Mode (MLS = ACKB = 0, WAIT = 1)..... | 508 |
| Figure 14.16 | An Example of the Stop Condition Issuance Timing in Master Receive Mode (MLS = ACKB = 0, WAIT = 1)..... | 509 |
| Figure 14.17 | Example: Flowchart of Operations in the Slave Receive Mode (HNDS = 1) | 510 |
| Figure 14.18 | An Example of the Timing of Operations in Slave Receive Mode 1 (MLS = 0, HNDS = 1)..... | 512 |

| | | |
|--------------|---|-----|
| Figure 14.19 | An Example of the Timing of Operations in Slave Receive Mode 2 (MLS = 0, HNDS = 1)..... | 513 |
| Figure 14.20 | Example: Flowchart of Operations in Slave Transmit Mode (HNDS = 0)..... | 514 |
| Figure 14.21 | An Example of the Timing of Operations in Slave Receive Mode 1 (MLS = ACKB = 0, HNDS = 0)..... | 516 |
| Figure 14.22 | An Example of the Timing of Operations in Slave Receive Mode 2 (MLS = ACKB = 0, HNDS = 0)..... | 517 |
| Figure 14.23 | Example: Flowchart of Operations in Slave Transmit Mode | 518 |
| Figure 14.24 | An Example of the Timing of Operations in Slave Transmit Mode (MLS = 0).... | 520 |
| Figure 14.25 | IRIC Flag Set Timing and the Control of SCL (1) | 521 |
| Figure 14.26 | IRIC Flag Set Timing and the Control of SCL (2) | 522 |
| Figure 14.27 | IRIC Flag Set Timing and the Control of SCL (3) | 523 |
| Figure 14.28 | Block Diagram of the Noise Canceller | 526 |
| Figure 14.29 | Points for Caution in Reading Data Received by Master Reception | 533 |
| Figure 14.30 | Flowchart and Timing of the Execution of the Instruction that Sets the Start Condition for Re-Transmission | 534 |
| Figure 14.31 | Timing for the Setting of the Stop Condition | 535 |
| Figure 14.32 | IRIC Flag Clear Timing on WAIT Operation | 536 |
| Figure 14.33 | Timing for Clearing IRIC Flag When WAIT = 1 | 536 |
| Figure 14.34 | Timing for Reading ICDR and Accessing ICCR in Slave Transmit Mode | 537 |
| Figure 14.35 | Timing for Setting TRS Bit in Slave Mode | 538 |

Section 15 A/D Converter

| | | |
|-------------|--|-----|
| Figure 15.1 | Block Diagram of A/D Converter..... | 542 |
| Figure 15.2 | A/D Conversion Timing | 551 |
| Figure 15.3 | External Trigger Input Timing | 552 |
| Figure 15.4 | Definitions of A/D Conversion Accuracy | 555 |
| Figure 15.5 | Definitions of A/D Conversion Accuracy | 555 |
| Figure 15.6 | Example of Analog Input Circuit | 556 |
| Figure 15.7 | Example of Analog Input Protection Circuit | 558 |

Section 16 Compare Match Timer (CMT)

| | | |
|-------------|---|-----|
| Figure 16.1 | CMT Block Diagram..... | 559 |
| Figure 16.2 | Counter Operation | 563 |
| Figure 16.3 | Count Timing | 563 |
| Figure 16.4 | CMF Set Timing..... | 564 |
| Figure 16.5 | Timing of CMF Clear by CPU | 565 |
| Figure 16.6 | CMCNT Write and Compare Match Contention..... | 566 |
| Figure 16.7 | CMCNT Word Write and Increment Contention | 567 |
| Figure 16.8 | CMCNT Byte Write and Increment Contention..... | 568 |

Section 18 I/O Ports

| | | |
|-------------|----------------------|-----|
| Figure 18.1 | Port A (SH7144)..... | 634 |
| Figure 18.2 | Port A (SH7145)..... | 635 |
| Figure 18.3 | Port B..... | 639 |
| Figure 18.4 | Port C..... | 642 |
| Figure 18.5 | Port D (SH7144)..... | 645 |
| Figure 18.6 | Port D (SH7145)..... | 646 |
| Figure 18.7 | Port E (SH7144)..... | 650 |
| Figure 18.8 | Port E (SH7145)..... | 651 |
| Figure 18.9 | Port F..... | 654 |

Section 19 Flash Memory (F-ZTAT Version)

| | | |
|--------------|--|-----|
| Figure 19.1 | Block Diagram of Flash Memory..... | 658 |
| Figure 19.2 | Flash Memory State Transitions..... | 659 |
| Figure 19.3 | Boot Mode..... | 661 |
| Figure 19.4 | User Program Mode..... | 662 |
| Figure 19.5 | Flash Memory Block Configuration..... | 663 |
| Figure 19.6 | Programming/Erasing Flowchart Example in User Program Mode..... | 673 |
| Figure 19.7 | Flowchart for Flash Memory Emulation in RAM..... | 674 |
| Figure 19.8 | Example of RAM Overlap Operation (RAM[2:0] = B'000)..... | 675 |
| Figure 19.9 | Program/Program-Verify Flowchart..... | 677 |
| Figure 19.10 | Erase/Erase-Verify Flowchart..... | 679 |
| Figure 19.11 | Power On/Off Timing (Boot Mode)..... | 685 |
| Figure 19.12 | Power On/Off Timing (User Program Mode)..... | 686 |
| Figure 19.13 | Mode Transit Timing (Example: Boot Mode → User Mode ⇔ User Program Mode)..... | 687 |

Section 20 Mask ROM

| | | |
|-------------|-----------------------------|-----|
| Figure 20.1 | Mask ROM Block Diagram..... | 689 |
|-------------|-----------------------------|-----|

Section 22 User Debugging Interface (H-UDI)

| | | |
|-------------|---|-----|
| Figure 22.1 | H-UDI Block Diagram..... | 694 |
| Figure 22.2 | Data Input/Output Timing Chart (1)..... | 701 |
| Figure 22.3 | Data Input/Output Timing Chart (2)..... | 702 |
| Figure 22.4 | Data Input/Output Timing Chart (3)..... | 702 |
| Figure 22.5 | Serial Data Input/Output..... | 704 |

Section 23 Advanced User Debugger (AUD)

| | | |
|-------------|---|-----|
| Figure 23.1 | AUD Block Diagram..... | 706 |
| Figure 23.2 | Example of Data Output (32-Bit Output)..... | 711 |
| Figure 23.3 | Example of Output in Case of Successive Branches..... | 711 |
| Figure 23.4 | AUDATA Input Format..... | 712 |

| | | |
|-------------|---|-----|
| Figure 23.5 | Example of Read Operation (Byte Read) | 714 |
| Figure 23.6 | Example of Write Operation (Longword Write) | 714 |
| Figure 23.7 | Example of Error Occurrence (Longword Read)..... | 714 |

Section 24 Power-Down Modes

| | | |
|-------------|---|-----|
| Figure 24.1 | NMI Timing in Software Standby Mode (Application Example) | 730 |
|-------------|---|-----|

Section 26 Electrical Characteristics

| | | |
|--------------|---|-----|
| Figure 26.1 | Output Load Circuit..... | 771 |
| Figure 26.2 | System Clock Timing | 773 |
| Figure 26.3 | EXTAL Clock Input Timing | 773 |
| Figure 26.4 | Oscillation Settling Time..... | 773 |
| Figure 26.5 | Reset Input Timing | 775 |
| Figure 26.6 | Interrupt Signal Input Timing..... | 775 |
| Figure 26.7 | Interrupt Signal Output Timing | 776 |
| Figure 26.8 | Bus Release Timing..... | 776 |
| Figure 26.9 | Basic Cycle (No Waits) | 778 |
| Figure 26.10 | Basic Cycle (One Software Wait)..... | 779 |
| Figure 26.11 | Basic Cycle (Two Software Waits + Waits by WAIT Signal) | 780 |
| Figure 26.12 | $\overline{\text{DREQ0}}$, $\overline{\text{DREQ1}}$ Input Timing (1)..... | 781 |
| Figure 26.13 | $\overline{\text{DREQ0}}$, $\overline{\text{DREQ1}}$ Input Timing (2)..... | 782 |
| Figure 26.14 | DRAK Output Delay Time..... | 782 |
| Figure 26.15 | MTU Input/Output timing | 783 |
| Figure 26.16 | MTU Clock Input Timing..... | 783 |
| Figure 26.17 | I/O Port Input/Output timing | 784 |
| Figure 26.18 | WDT Timing | 785 |
| Figure 26.19 | SCI Input Timing..... | 787 |
| Figure 26.20 | SCI Input/Output Timing..... | 787 |
| Figure 26.21 | I ² C Bus Interface Timing..... | 789 |
| Figure 26.22 | POE Input/Output Timing | 789 |
| Figure 26.23 | External Trigger Input Timing | 790 |
| Figure 26.24 | H-UDI Clock Timing | 791 |
| Figure 26.25 | H-UDI $\overline{\text{TRST}}$ Timing | 792 |
| Figure 26.26 | H-UDI Input/Output Timing | 792 |
| Figure 26.27 | AUD Reset Timing..... | 794 |
| Figure 26.28 | Branch Trace Timing..... | 794 |
| Figure 26.29 | RAM Monitor Timing | 794 |

Appendix D I/O Port Block Diagrams

| | | |
|------------|--|-----|
| Figure D.1 | PAn/RXDm | 813 |
| Figure D.2 | PAn/TXDm..... | 814 |
| Figure D.3 | PAn/SCKm/ $\overline{\text{DREQm}}$ / $\overline{\text{IRQm}}$ | 815 |

| | | |
|-------------|--|-----|
| Figure D.4 | PAn/TCLKm/ $\overline{\text{CSx}}$ | 816 |
| Figure D.5 | PAn/TCLKm/ $\overline{\text{IRQx}}$ | 817 |
| Figure D.6 | PAn/Function 1..... | 818 |
| Figure D.7 | PA15/CK | 819 |
| Figure D.8 | PA16/ $\overline{\text{AUDSYNC}}$ | 820 |
| Figure D.9 | PA17/ $\overline{\text{WAIT}}$ | 821 |
| Figure D.10 | PA18/ $\overline{\text{BREQ/DRAK0}}$ | 822 |
| Figure D.11 | PA19/ $\overline{\text{BACK/DRAK1}}$ | 823 |
| Figure D.12 | PAn..... | 824 |
| Figure D.13 | PAn/Function 2..... | 825 |
| Figure D.14 | PBn/Am..... | 826 |
| Figure D.15 | PBn/ $\overline{\text{IRQm/POEm}}$ /Function 1 | 827 |
| Figure D.16 | PBn/ $\overline{\text{IRQm/POEm}}$ | 828 |
| Figure D.17 | PBn/ $\overline{\text{IRQm/POEm/CSx}}$ | 829 |
| Figure D.18 | PB6/ $\overline{\text{IRQ4/A18/BACK}}$ | 830 |
| Figure D.19 | PB7/ $\overline{\text{IRQ5/A19/BREQ}}$ | 831 |
| Figure D.20 | PB8/ $\overline{\text{IRQ6/A20/WAIT}}$ | 832 |
| Figure D.21 | PB9/ $\overline{\text{IRQ7/A21/ADTRG}}$ | 833 |
| Figure D.22 | PCn/An | 834 |
| Figure D.23 | PDn/Dn..... | 835 |
| Figure D.24 | PDn/Dn/AUDATAm..... | 836 |
| Figure D.25 | PDn/Dn/Function 1..... | 837 |
| Figure D.26 | PDn/Dn/Function 2..... | 838 |
| Figure D.27 | PDn/Dn/ $\overline{\text{IRQm}}$ | 839 |
| Figure D.28 | PDn/Dn/ $\overline{\text{IRQm/AUDATAm}}$ | 840 |
| Figure D.29 | PDn/Dn/ $\overline{\text{IRQm}}$ /Function 1..... | 841 |
| Figure D.30 | PDn/Dn/ $\overline{\text{IRQm}}$ /Function 2..... | 842 |
| Figure D.31 | PDn/Dn/Function 3..... | 843 |
| Figure D.32 | PDn/Dn/Function 4..... | 844 |
| Figure D.33 | PDn/Dn/ $\overline{\text{CSm}}$ | 845 |
| Figure D.34 | PEn/TIOCxx/Function 1..... | 846 |
| Figure D.35 | PEn/TIOCxx/Function 2..... | 847 |
| Figure D.36 | PEn/TIOCxx/SCKm..... | 848 |
| Figure D.37 | PE9/TIOC3B/SCK3 | 849 |
| Figure D.38 | PE11/TIOC3D/RXD3..... | 850 |
| Figure D.39 | PE12/TIOC4A/TXD3..... | 851 |
| Figure D.40 | PE13/TIOC4B/ $\overline{\text{MRES}}$ | 852 |
| Figure D.41 | PE14/TIOC4C/DACK0 | 853 |
| Figure D.42 | PE15/TIOC4D/DACK1/ $\overline{\text{IRQOUT}}$ | 854 |
| Figure D.43 | PEn/TIOCxx/Function 1/Function 2..... | 855 |

| | | |
|-------------|---|-----|
| Figure D.44 | PE1/TIOC0B/DRAK0/ $\overline{\text{TRST}}$ | 856 |
| Figure D.45 | PE3/TIOC0D/DRAK1/TDO..... | 857 |
| Figure D.46 | PE0/TIOC0A/ $\overline{\text{DREQ0}}$ /AUDCK | 858 |
| Figure D.47 | PE1/TIOC0B/DRAK0/AUDMD | 859 |
| Figure D.48 | PE2/TIOC0C/ $\overline{\text{DREQ1}}$ / $\overline{\text{AUDRST}}$ | 860 |
| Figure D.49 | PE _n /TIOC _{xx} /Function 1/AUDATA _m | 861 |
| Figure D.50 | PE4/TIOC1A/RXD3/AUDATA2 | 862 |
| Figure D.51 | PE6/TIOC2A/SCK3/AUDATA0..... | 863 |
| Figure D.52 | PE8/TIOC3A/SCK2/TMS | 864 |
| Figure D.53 | PE9/TIOC3B/SCK3/ $\overline{\text{TRST}}$ | 865 |
| Figure D.54 | PE10/TIOC3C/TXD2/TDI | 866 |
| Figure D.55 | PE11/TIOC3D/RXD3/TDO | 867 |
| Figure D.56 | PE12/TIOC4A/TXD3/TCK..... | 868 |
| Figure D.57 | PF _n /AN _n | 869 |

Appendix E Package Dimensions

| | | |
|------------|---------------|-----|
| Figure E.1 | FP-112B | 870 |
| Figure E.2 | FP-144F..... | 871 |

Tables

Section 2 CPU

| | | |
|------------|---|----|
| Table 2.1 | Initial Values of Registers..... | 18 |
| Table 2.2 | Sign Extension of Word Data | 21 |
| Table 2.3 | Delayed Branch Instructions..... | 22 |
| Table 2.4 | T Bit | 22 |
| Table 2.5 | Immediate Data Accessing..... | 23 |
| Table 2.6 | Absolute Address Accessing..... | 23 |
| Table 2.7 | Displacement Accessing | 24 |
| Table 2.8 | Addressing Modes and Effective Addresses..... | 25 |
| Table 2.9 | Instruction Formats | 29 |
| Table 2.10 | Classification of Instructions | 32 |

Section 3 MCU Operating Modes

| | | |
|-----------|-----------------------------------|----|
| Table 3.1 | Selection of Operating Modes..... | 47 |
| Table 3.2 | Clock Mode Setting | 48 |
| Table 3.3 | Pin Configuration..... | 49 |

Section 4 Clock Pulse Generator

| | | |
|-----------|---|----|
| Table 4.1 | Operating Clock for Each Module | 54 |
| Table 4.2 | Damping Resistance Values (Recommended Values)..... | 55 |
| Table 4.3 | Crystal Resonator Characteristics | 56 |

Section 5 Exception Processing

| | | |
|------------|---|----|
| Table 5.1 | Types of Exception Processing and Priority Order | 61 |
| Table 5.2 | Timing for Exception Source Detection and Start of Exception Processing..... | 62 |
| Table 5.3 | Exception Processing Vector Table | 63 |
| Table 5.4 | Calculating Exception Processing Vector Table Addresses..... | 64 |
| Table 5.5 | Reset Status..... | 65 |
| Table 5.6 | Bus Cycles and Address Errors..... | 67 |
| Table 5.7 | Interrupt Sources..... | 69 |
| Table 5.8 | Interrupt Priority | 70 |
| Table 5.9 | Types of Exceptions Triggered by Instructions | 71 |
| Table 5.10 | Generation of Exception Sources Immediately after Delayed Branch Instruction or Interrupt-Disabled Instruction | 73 |
| Table 5.11 | Stack Status after Exception Processing Ends | 74 |

Section 6 Interrupt Controller (INTC)

| | | |
|-----------|--|----|
| Table 6.1 | Pin Configuration..... | 79 |
| Table 6.2 | Interrupt Exception Processing Vectors and Priorities..... | 90 |
| Table 6.3 | Interrupt Response Time..... | 96 |

Section 8 Data Transfer Controller (DTC)

| | | |
|-----------|---|-----|
| Table 8.1 | Interrupt Sources, DTC Vector Addresses, and Corresponding DTEs | 124 |
| Table 8.2 | Normal Mode Register Functions | 127 |
| Table 8.3 | Repeat Mode Register Functions | 128 |
| Table 8.4 | Block Transfer Mode Register Functions | 129 |
| Table 8.5 | Execution State of DTC | 133 |
| Table 8.6 | State Counts Needed for Execution State | 133 |

Section 9 Bus State Controller (BSC)

| | | |
|-----------|---|-----|
| Table 9.1 | Pin Configuration..... | 139 |
| Table 9.2 | Address Map..... | 142 |
| Table 9.3 | Access to On-chip Peripheral I/O Registers..... | 166 |

Section 10 Direct Memory Access Controller (DMAC)

| | | |
|-------------|---|-----|
| Table 10.1 | DMAC Pin Configuration..... | 169 |
| Table 10.2 | Selecting External Request Modes with RS Bits | 182 |
| Table 10.3 | Selecting On-Chip Peripheral Module Request Modes with RS Bits | 183 |
| Table 10.4 | Supported DMA Transfers..... | 187 |
| Table 10.5 | Relationship of Request Modes and Bus Modes by DMA Transfer Category | 196 |
| Table 10.6 | Transfer Conditions and Register Set Values for Transfer between On-chip SCI and External Memory | 206 |
| Table 10.7 | Transfer Conditions and Register Set Values for Transfer between External RAM and External Device with DACK..... | 207 |
| Table 10.8 | Transfer Conditions and Register Set Values for Transfer between A/D Converter (A/D1) and On-chip Memory | 208 |
| Table 10.9 | DMAC Internal Status | 209 |
| Table 10.10 | Transfer Conditions and Register Set Values for Transfer between External Memory and SCI1 Transmit Side..... | 210 |

Section 11 Multi-Function Timer Pulse Unit (MTU)

| | | |
|-------------|---|-----|
| Table 11.1 | MTU Functions..... | 214 |
| Table 11.2 | Pin Configuration..... | 217 |
| Table 11.3 | CCLR0 to CCLR2 (Channels 0, 3, and 4) | 221 |
| Table 11.4 | CCLR0 to CCLR2 (Channels 1 and 2) | 221 |
| Table 11.5 | TPSC0 to TPSC2 (Channel 0) | 222 |
| Table 11.6 | TPSC0 to TPSC2 (Channel 1) | 222 |
| Table 11.7 | TPSC0 to TPSC2 (Channel 2) | 223 |
| Table 11.8 | TPSC0 to TPSC2 (Channels 3 and 4) | 223 |
| Table 11.9 | MD0 to MD3 | 225 |
| Table 11.10 | TIORH_0 (Channel 0) | 228 |
| Table 11.11 | TIORL_0 (Channel 0)..... | 229 |
| Table 11.12 | TIOR_1 (Channel 1) | 230 |

| | | |
|-------------|---|-----|
| Table 11.13 | TIOR_2 (Channel 2) | 231 |
| Table 11.14 | TIORH_3 (Channel 3) | 232 |
| Table 11.15 | TIORL_3 (Channel 3)..... | 233 |
| Table 11.16 | TIORH_4 (Channel 4) | 234 |
| Table 11.17 | TIORL_4 (Channel 4)..... | 235 |
| Table 11.18 | TIORH_0 (Channel 0) | 236 |
| Table 11.19 | TIORL_0 (Channel 0)..... | 237 |
| Table 11.20 | TIOR_1 (Channel 1) | 238 |
| Table 11.21 | TIOR_2 (Channel 2) | 239 |
| Table 11.22 | TIORH_3 (Channel 3) | 240 |
| Table 11.23 | TIORL_3 (Channel 3)..... | 241 |
| Table 11.24 | TIORH_4 (Channel 4) | 242 |
| Table 11.25 | TIORL_4 (Channel 4)..... | 243 |
| Table 11.26 | Output Level Select Function | 253 |
| Table 11.27 | Output Level Select Function | 254 |
| Table 11.28 | Output level Select Function..... | 256 |
| Table 11.29 | Register Combinations in Buffer Operation | 266 |
| Table 11.30 | Cascaded Combinations..... | 269 |
| Table 11.31 | PWM Output Registers and Output Pins | 272 |
| Table 11.32 | Phase Counting Mode Clock Input Pins | 276 |
| Table 11.33 | Up/Down-Count Conditions in Phase Counting Mode 1 | 277 |
| Table 11.34 | Up/Down-Count Conditions in Phase Counting Mode 2..... | 278 |
| Table 11.35 | Up/Down-Count Conditions in Phase Counting Mode 3..... | 279 |
| Table 11.36 | Up/Down-Count Conditions in Phase Counting Mode 4..... | 280 |
| Table 11.37 | Output Pins for Reset-Synchronized PWM Mode | 282 |
| Table 11.38 | Register Settings for Reset-Synchronized PWM Mode | 282 |
| Table 11.39 | Output Pins for Complementary PWM Mode..... | 285 |
| Table 11.40 | Register Settings for Complementary PWM Mode | 286 |
| Table 11.41 | Registers and Counters Requiring Initialization | 293 |
| Table 11.42 | MTU Interrupts | 311 |
| Table 11.43 | Mode Transition Combinations | 337 |
| Table 11.44 | Pin Configuration..... | 370 |
| Table 11.45 | Pin Combinations..... | 370 |

Section 12 Watchdog Timer (WDT)

| | | |
|------------|---|-----|
| Table 12.1 | Pin Configuration..... | 380 |
| Table 12.2 | WDT Interrupt Source (in Interval Timer Mode) | 388 |

Section 13 Serial Communication Interface (SCI)

| | | |
|------------|---|-----|
| Table 13.1 | Pin Configuration..... | 395 |
| Table 13.2 | Relationships between N Setting in BRR and Effective Bit Rate B_0 | 416 |

| | | |
|-------------|---|-----|
| Table 13.3 | BRR Settings for Various Bit Rates (Asynchronous Mode) (1) | 418 |
| Table 13.3 | BRR Settings for Various Bit Rates (Asynchronous Mode) (2) | 418 |
| Table 13.3 | BRR Settings for Various Bit Rates (Asynchronous Mode) (3) | 419 |
| Table 13.3 | BRR Settings for Various Bit Rates (Asynchronous Mode) (4) | 419 |
| Table 13.4 | Maximum Bit Rate for Each Frequency when Using Baud Rate Generator (Asynchronous Mode) | 420 |
| Table 13.5 | Maximum Bit Rate with External Clock Input (Asynchronous Mode) | 421 |
| Table 13.6 | BRR Settings for Various Bit Rates (Clock Synchronous Mode) (1) | 422 |
| Table 13.6 | BRR Settings for Various Bit Rates (Clock Synchronous Mode) (2) | 422 |
| Table 13.6 | BRR Settings for Various Bit Rates (Clock Synchronous Mode) (3) | 423 |
| Table 13.6 | BRR Settings for Various Bit Rates (Clock Synchronous Mode) (4) | 423 |
| Table 13.7 | Maximum Bit Rate with External Clock Input (Clock Synchronous Mode) | 424 |
| Table 13.8 | Examples of Bit Rate for Various BRR Settings (Smart Card Interface Mode) (When $n = 0$ and $S = 372$)..... | 425 |
| Table 13.9 | Maximum Bit Rate at Various Frequencies (Smart Card Interface Mode) (when $S = 372$)..... | 425 |
| Table 13.10 | Serial Transfer Formats (Asynchronous Mode)..... | 427 |
| Table 13.11 | SSR Status Flags and Receive Data Handling | 434 |
| Table 13.12 | Interrupt Sources in Serial Communication Interface Mode | 461 |
| Table 13.13 | Interrupt Sources in Smart Card Interface Mode | 462 |

Section 14 I²C Bus Interface (IIC) Option

| | | |
|-------------|---|-----|
| Table 14.1 | Pin Configuration..... | 470 |
| Table 14.2 | Transfer Format | 473 |
| Table 14.3 | Setting of the Transfer Rate | 476 |
| Table 14.4 | The Relationship between Flags and Transfer States (Master Mode)..... | 483 |
| Table 14.5 | The Relationship between Flags and Transfer States (Slave Mode)..... | 484 |
| Table 14.6 | I ² C Bus Data Format: Description of Symbols | 494 |
| Table 14.7 | Examples of Operations in which the DTC Is Used | 525 |
| Table 14.8 | I ² C Bus Timing (output of SCL and SDA) | 528 |
| Table 14.9 | Tolerance of the SCL Rise Time (t_{sr}) | 529 |
| Table 14.10 | I ² C Bus Timing (when the effect of t_{sr}/t_{sr} Is at its maximum)..... | 531 |

Section 15 A/D Converter

| | | |
|------------|--|-----|
| Table 15.1 | Pin Configuration..... | 543 |
| Table 15.2 | Channel Select List | 546 |
| Table 15.3 | A/D Conversion Time (Single Mode)..... | 551 |
| Table 15.4 | A/D Conversion Time (Scan Mode) | 552 |
| Table 15.5 | A/D Converter Interrupt Sources | 553 |
| Table 15.6 | Analog Pin Specifications..... | 558 |

Section 17 Pin Function Controller (PFC)

| | | |
|-------------|---|-----|
| Table 17.1 | SH7144 Multiplexed Pins (Port A)..... | 569 |
| Table 17.2 | SH7144 Multiplexed Pins (Port B)..... | 570 |
| Table 17.3 | SH7144 Multiplexed Pins (Port C)..... | 570 |
| Table 17.4 | SH7144 Multiplexed Pins (Port D)..... | 571 |
| Table 17.5 | SH7144 Multiplexed Pins (Port E)..... | 572 |
| Table 17.6 | SH7144 Multiplexed Pins (Port F)..... | 572 |
| Table 17.7 | SH7145 Multiplexed Pins (Port A)..... | 573 |
| Table 17.8 | SH7145 Multiplexed Pins (Port B)..... | 574 |
| Table 17.9 | SH7145 Multiplexed Pins (Port C)..... | 574 |
| Table 17.10 | SH7145 Multiplexed Pins (Port D)..... | 575 |
| Table 17.11 | SH7145 Multiplexed Pins (Port E)..... | 576 |
| Table 17.12 | SH7145 Multiplexed Pins (Port F)..... | 576 |
| Table 17.13 | SH7144 Pin Functions in Each Mode (1)..... | 577 |
| Table 17.13 | SH7144 Pin Functions in Each Mode (2)..... | 581 |
| Table 17.14 | SH7145 Pin Functions in Each Mode (1)..... | 585 |
| Table 17.14 | SH7145 Pin Functions in Each Mode (2)..... | 590 |
| Table 17.15 | Transmit Forms of Input Functions Allocated to Multiple Pins..... | 631 |

Section 18 I/O Ports

| | | |
|------------|---|-----|
| Table 18.1 | Port A Data Register (PADR) Read/Write Operations..... | 638 |
| Table 18.2 | Port B Data Register (PBDR) Read/Write Operations..... | 641 |
| Table 18.3 | Port C Data Register (PCDR) Read/Write Operations..... | 644 |
| Table 18.4 | Port D Data Register (PDDR) Read/Write Operations..... | 649 |
| Table 18.5 | Port E Data Register L (PEDRL) Read/Write Operations..... | 653 |
| Table 18.6 | Port F Data Register (PFDR) Read/Write Operations..... | 655 |

Section 19 Flash Memory (F-ZTAT Version)

| | | |
|------------|--|-----|
| Table 19.1 | Differences between Boot Mode and User Program Mode..... | 660 |
| Table 19.2 | Pin Configuration..... | 664 |
| Table 19.3 | Setting On-Board Programming Modes..... | 670 |
| Table 19.4 | Boot Mode Operation..... | 672 |
| Table 19.5 | Peripheral Clock (P ϕ) Frequencies for which Automatic Adjustment of LSI Bit Rate Is Possible..... | 672 |

Section 22 User Debugging Interface (H-UDI)

| | | |
|------------|---|-----|
| Table 22.1 | H-UDI Pins..... | 695 |
| Table 22.2 | Serial Transfer Characteristics of H-UDI Registers..... | 696 |

Section 23 Advanced User Debugger (AUD)

| | | |
|------------|----------------------------|-----|
| Table 23.1 | AUD Pin Configuration..... | 707 |
| Table 23.2 | Ready Flag Format..... | 713 |

Section 24 Power-Down Modes

| | | |
|------------|--|-----|
| Table 24.1 | Internal Operation States in Each Mode | 720 |
| Table 24.2 | Pin Configuration..... | 721 |

Section 26 Electrical Characteristics

| | | |
|-------------|--|-----|
| Table 26.1 | Absolute Maximum Ratings | 767 |
| Table 26.2 | DC Characteristics | 768 |
| Table 26.3 | Permitted Output Current Values..... | 770 |
| Table 26.4 | Clock Timing | 772 |
| Table 26.5 | Control Signal Timing | 774 |
| Table 26.6 | Bus Timing | 777 |
| Table 26.7 | Direct Memory Access Controller Timing | 781 |
| Table 26.8 | Multi-Function Timer Pulse Unit Timing | 783 |
| Table 26.9 | I/O Port Timing..... | 784 |
| Table 26.10 | Watchdog Timer Timing..... | 785 |
| Table 26.11 | Serial Communication Interface Timing..... | 786 |
| Table 26.12 | I ² C Bus Interface Timing | 788 |
| Table 26.13 | Port Output Enable Timing | 789 |
| Table 26.14 | A/D Converter Timing | 790 |
| Table 26.15 | H-UDI Timing | 791 |
| Table 26.16 | AUD Timing..... | 793 |
| Table 26.17 | A/D Converter Characteristics | 795 |
| Table 26.18 | Flash Memory Characteristics | 796 |

Appendix A Pin States

| | | |
|-----------|--------------------------|-----|
| Table A.1 | Pin States (SH7144)..... | 799 |
| Table A.2 | Pin States (SH7145)..... | 803 |
| Table A.3 | Pin States | 807 |
| Table A.4 | Pin States | 807 |
| Table A.5 | Pin States | 808 |

Appendix B Pin States of Bus Related Signals

| | | |
|-----------|--|-----|
| Table B.1 | Pin States of Bus Related Signals (1)..... | 809 |
| Table B.1 | Pin States of Bus Related Signals (2)..... | 810 |
| Table B.1 | Pin States of Bus Related Signals (3)..... | 811 |

Section 1 Overview

The SH7144 Group and SH7145 Group single-chip RISC (Reduced Instruction Set Computer) microcomputers integrate a Renesas Technology original RISC CPU core with peripheral functions required for system configuration.

The SH7144 Group and SH7145 Group CPU has a RISC-type instruction set. Most instructions can be executed in one state (one system clock cycle), which greatly improves instruction execution speed. In addition, the 32-bit internal-bus architecture enhances data processing power. With this CPU, it has become possible to assemble low cost, high performance/high-functioning systems, even for applications that were previously impossible with microcomputers, such as real-time control, which demands high speeds.

In addition, the SH7144 Group and SH7145 Group includes on-chip peripheral functions necessary for system configuration, such as a direct memory access controller (DMAC), large-capacity ROM and RAM, timers, a serial communication interface (SCI), an A/D converter, an interrupt controller (INTC), and I/O ports. As an option, an I²C bus interface can also be incorporated.

ROM and SRAM can be directly connected to the SH7144 Group and SH7145 Group MCU by means of an external memory access support function. This greatly reduces system cost.

There are two versions of on-chip ROM: F-ZTATTM* (Flexible Zero Turn Around Time) that includes flash memory, and masked ROM. The flash memory can be programmed with a programmer that supports SH7144 Group and SH7145 Group programming, and can also be programmed and erased by software. This enables LSI chip to be re-programmed at a user side while mounted on a board.

Note: * F-ZTAT is a registered trademark of Renesas Technology Corp.

1.1 Features

- Central processing unit with an internal 32-bit RISC (Reduced Instruction Set Computer) architecture
 - Instruction length: 16-bit fixed length for improved code efficiency
 - Load-store architecture (basic operations are executed between registers)
 - Sixteen 32-bit general registers
 - Five-stage pipeline
 - On-chip multiplier: multiplication operations (32 bits × 32 bits → 64 bits) executed in two to four cycles
 - C language-oriented 62 basic instructions
- Various peripheral functions
 - Direct memory access controller (DMAC)
 - Data transfer controller (DTC)
 - Multifunction timer/pulse unit (MTU)
 - Compare match timer (CMT)
 - Watchdog timer (WDT)
 - Asynchronous or clocked synchronous serial communication interface (SCI)
 - I²C bus interface (IIC)*¹
 - 10-bit A/D converter
 - Clock pulse generator
 - User break controller (UBC)
 - User debugging interface (H-UDI)*²
 - Advanced user debugger (AUD)*²

Notes: 1. Option
2. Supported only for flash memory version.

- On-chip memory

| ROM | Part No. | ROM | RAM |
|----------------------|--------------|------------|----------|
| Flash memory version | HD64F7144F50 | 256 kbytes | 8 kbytes |
| | HD64F7145F50 | 256 kbytes | 8 kbytes |
| Masked ROM version | HD6437144F50 | 256 kbytes | 8 kbytes |
| | HD6437145F50 | 256 kbytes | 8 kbytes |
| ROM less version | HD6417144F50 | — | 8 kbytes |
| | HD6417145F50 | — | 8 kbytes |

- I/O ports

| Part No. | No. of I/O Pins | No. of Input-Only Pins |
|--|-----------------|------------------------|
| HD64F7144F50/ HD6437144F50/ HD6417144F50 | 74 | 8 |
| HD64F7145F50/ HD6437145F50/ HD6417145F50 | 98 | 8 |

- Supports various power-down states
- Compact package

| Part No. | Package | (Code) | Body Size | Pin Pitch |
|--|----------|---------|----------------|-----------|
| HD64F7144F50/ HD6437144F50/ HD6417144F50 | QFP-112 | FP-112B | 20.0 × 20.0 mm | 0.65 mm |
| HD64F7145F50/ HD6437145F50/ HD6417145F50 | LQFP-144 | FP-144F | 20.0 × 20.0 mm | 0.5 mm |

1.2 Internal Block Diagram

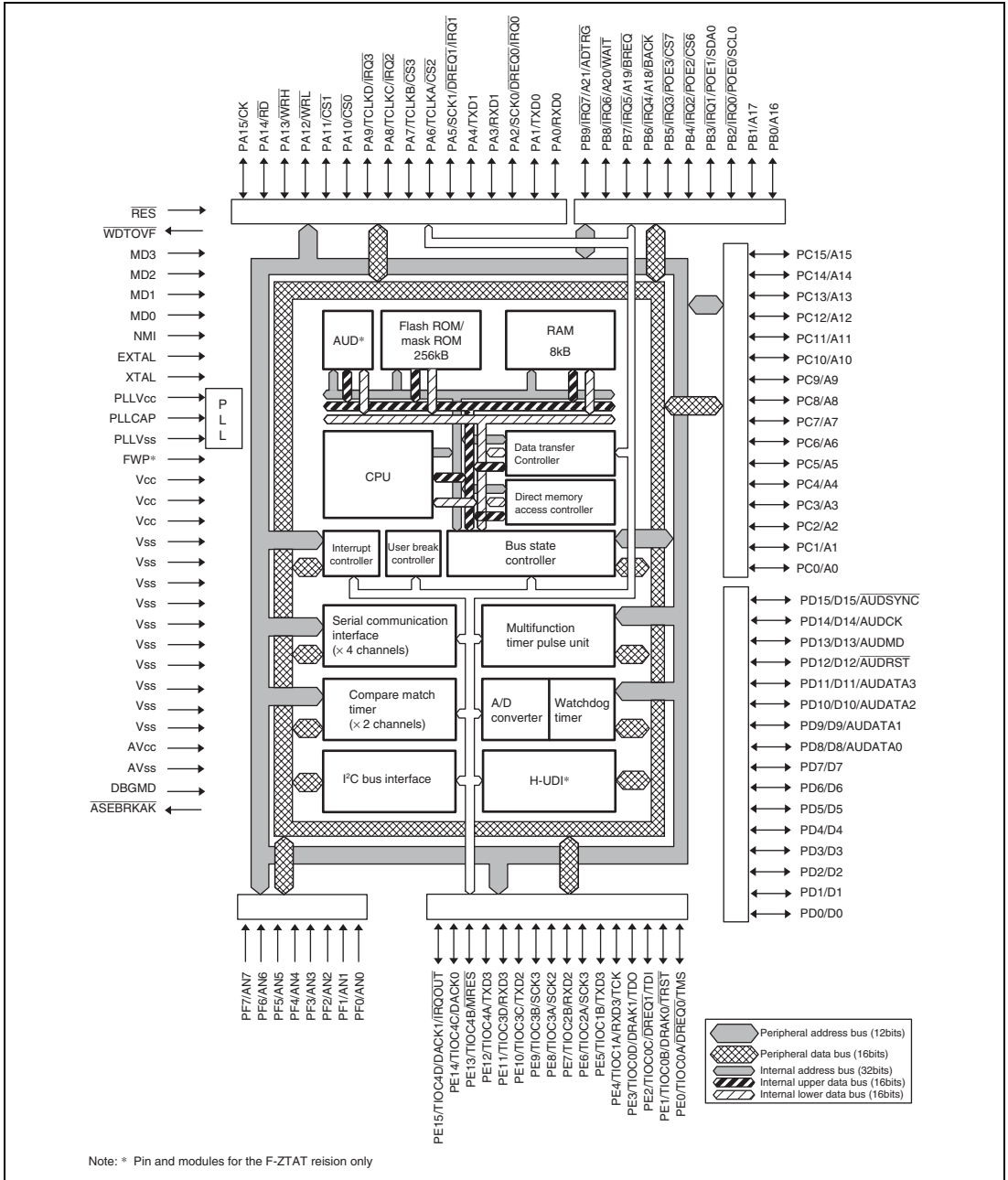
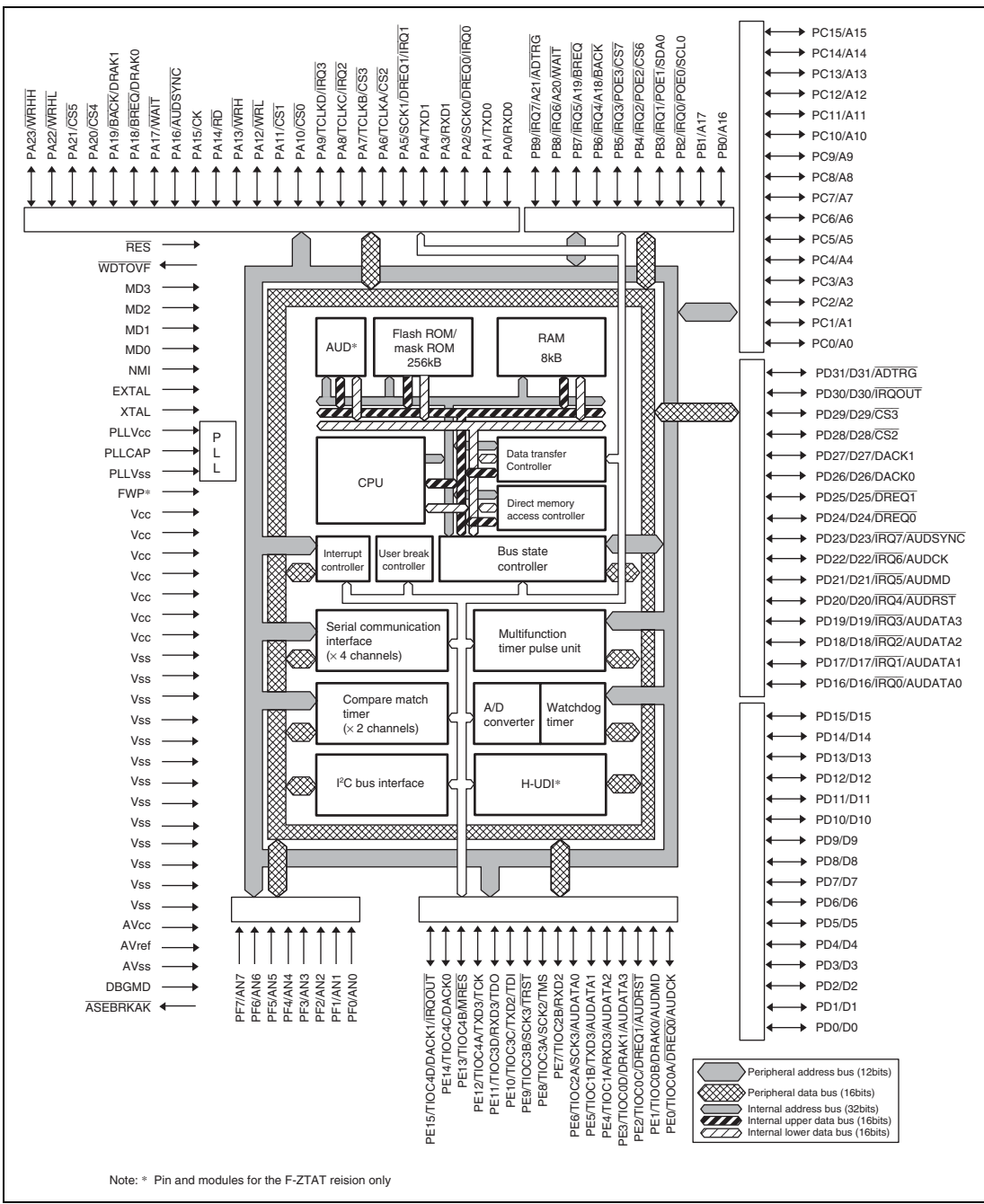

Figure 1.1 Internal Block Diagram of SH7144



Note: * Pin and modules for the F-ZTAT reision only

Figure 1.2 Block Diagram of SH7145



1.3 Pin Arrangement

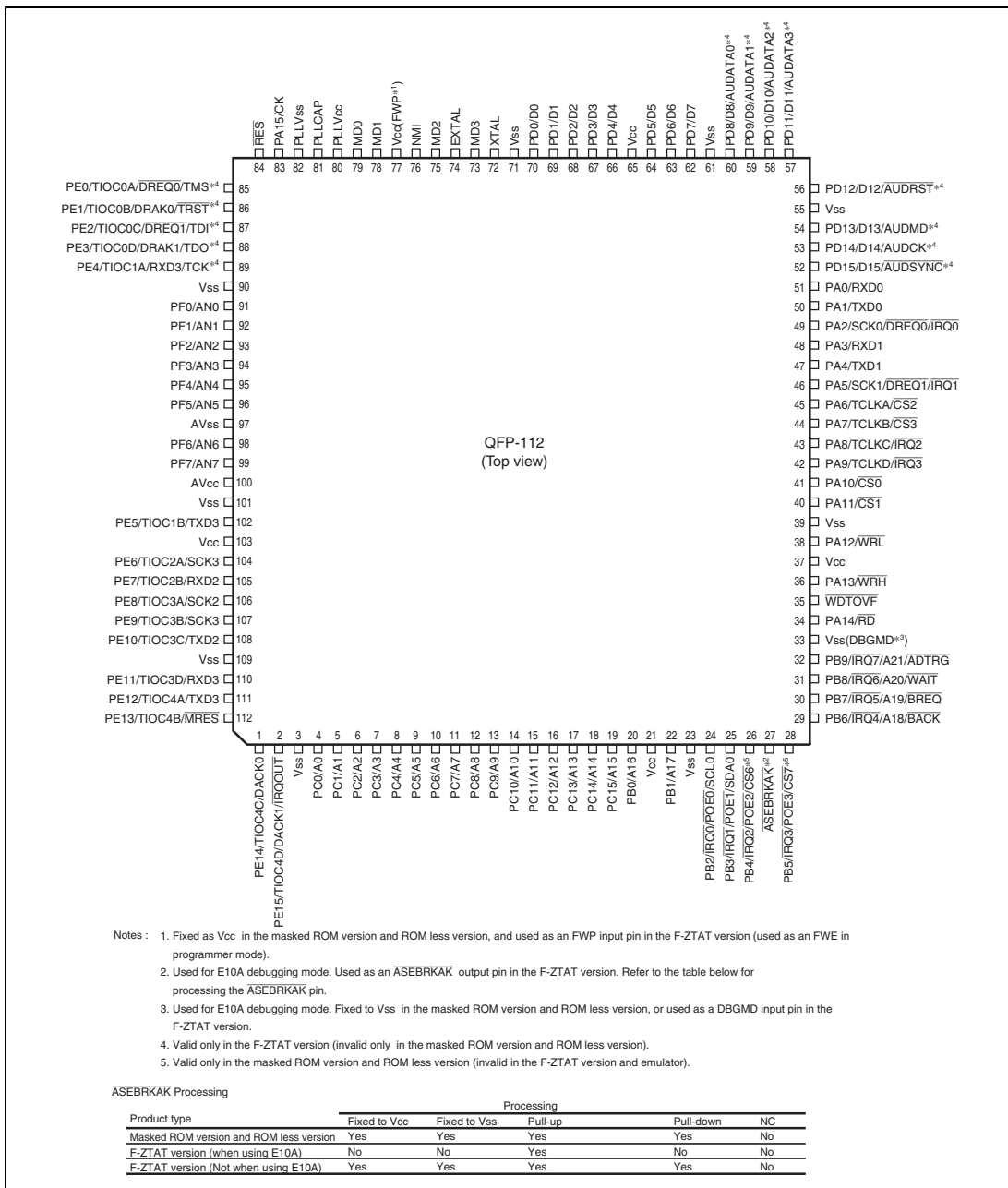

- Notes :
1. Fixed as Vcc in the masked ROM version and ROM less version, and used as an FWP input pin in the F-ZTAT version (used as an FWE in programmer mode).
 2. Used for E10A debugging mode. Used as an ASEBRKAK output pin in the F-ZTAT version. Refer to the table below for processing the ASEBRKAK pin.
 3. Used for E10A debugging mode. Fixed to Vss in the masked ROM version and ROM less version, or used as a DBGMD input pin in the F-ZTAT version.
 4. Valid only in the F-ZTAT version (invalid only in the masked ROM version and ROM less version).
 5. Valid only in the masked ROM version and ROM less version (invalid in the F-ZTAT version and emulator).

ASEBRKAK Processing

| Product type | Processing | | | | |
|---|--------------|--------------|---------|-----------|----|
| | Fixed to Vcc | Fixed to Vss | Pull-up | Pull-down | NC |
| Masked ROM version and ROM less version | Yes | Yes | Yes | Yes | No |
| F-ZTAT version (when using E10A) | No | No | Yes | No | No |
| F-ZTAT version (Not when using E10A) | Yes | Yes | Yes | Yes | No |

Figure 1.3 SH7144 Pin Arrangement



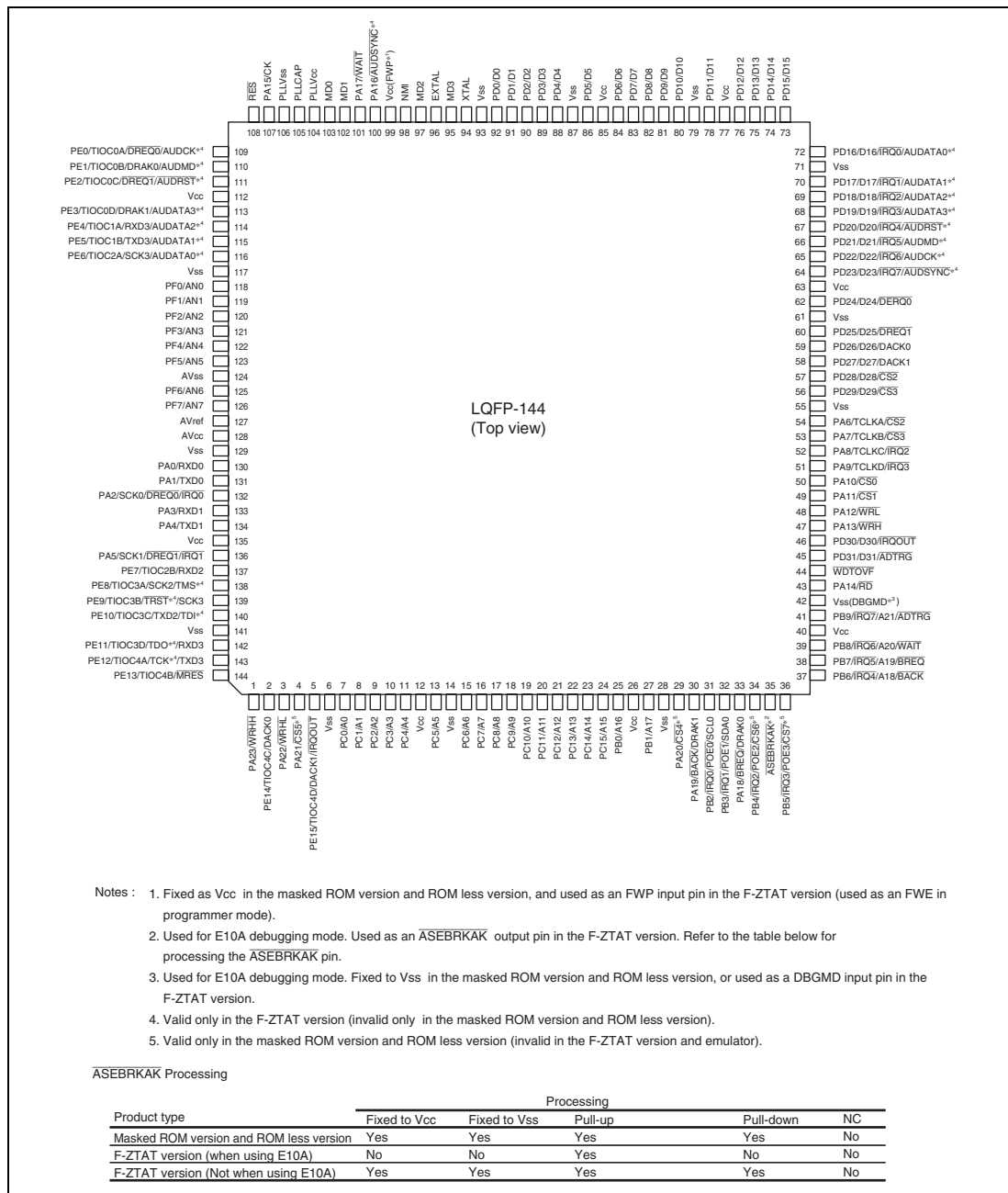

Figure 1.4 SH7145 Pin Arrangement

1.4 Pin Functions

| Type | Symbol | I/O | Name | Function |
|------------------------|----------------|--------|--|--|
| Power Supply | V_{CC} | Input | Power supply | Power supply pins. Connect all these pins to the system power supply. The chip does not operate when some of these pins are opened. |
| | V_{SS} | Input | Ground | Ground pins. Connect all these pins to the system power supply (0 V). The chip does not operate when some of these pins are opened. |
| Clock | $PLL_{V_{CC}}$ | Input | Power supply for PLL | Power supply pin for supplying power to on-chip PLL. |
| | $PLL_{V_{SS}}$ | Input | Ground for PLL | On-chip PLL oscillator ground pin. |
| | PLLCAP | Input | Capacitance for PLL | External capacitance pin for an on-chip PLL oscillator. |
| | EXTAL | Input | External clock | For connection to a crystal resonator. (An external clock can be supplied from the EXTAL pin.) For examples of crystal resonator connection and external clock input, see section 4, Clock Pulse Generator. |
| | XTAL | Input | Crystal | For connection to a crystal resonator. For examples of crystal resonator connection and external clock input, see section 4, Clock Pulse Generator. |
| | CK | Output | System clock output | Supplies the system clock to external devices. |
| Operating mode control | MD3 to MD0 | Input | Set the mode | Set the operating mode. Inputs at these pins should not be changed during operation. |
| | FWP | Input | Protection against write operation into flash memory | Pin for the flash memory. This pin is only used in the F-ZTAT version. Programming or erasing of flash memory can be protected. This pin is used as V_{CC} in the masked ROM version and ROM less version. |

| Type | Symbol | I/O | Name | Function |
|----------------|--|------------------|--------------------------|---|
| System control | $\overline{\text{RES}}$ | Input | Power on reset | When this pin is driven low, the chip becomes to power on reset state. |
| | $\overline{\text{MRES}}$ | Input | Manual reset | When this pin is driven low, the chip becomes to manual reset state. |
| | $\overline{\text{WDTOVF}}$ | Output | Watchdog timer overflow | Output signal for the watchdog timer overflow. If this pin needs to be pulled-down, the resistance value must be 1 M Ω or higher. |
| | $\overline{\text{BREQ}}$ | Input | Bus request | External device can request the release of the bus mastership by setting this pin low. |
| | $\overline{\text{BACK}}$ | Output | Bus acknowledge | Shows that the bus mastership has been released for the external device. The device that had issued the $\overline{\text{BREQ}}$ signal can know that bus mastership has been released for itself by receiving the $\overline{\text{BACK}}$ signal. |
| Interrupts | $\overline{\text{NMI}}$ | Input | Non-maskable interrupt | Non-maskable interrupt pin. If this pin is not used, it should be fixed high or low. |
| | $\overline{\text{IRQ7}}$ to $\overline{\text{IRQ0}}$ | Input | Interrupt request 7 to 0 | These pins request a maskable interrupt. One of the level input or edge input can be selected. In case of the edge input, one of the rising edge, falling edge, or both can be selected. |
| | $\overline{\text{IRQOUT}}$ | Output | Interrupt request output | Shows that an interrupt cause has occurred. The interrupt cause can be recognized even in the bus release state. |
| Address bus | A21 to A0 | Output | Address bus | Output the address. |
| Data bus | SH7144: D15 to D0 SH7145: D31 to D0 | Input/ Output | Data bus | SH7144: Bi-directional 16-bit bus SH7145: Bi-directional 32-bit bus |

| Type | Symbol | I/O | Name | Function |
|--|--|--------|-----------------------------|--|
| Bus control | $\overline{CS3}$ to $\overline{CS0}$ | Output | Chip select 3 to 0 | Chip select signal for external memory or devices. |
| | $\overline{CS5}$, $\overline{CS4}$ (SH7145 masked ROM version and ROM less version only) | Output | Chip select 5, 4 | |
| | $\overline{CS7}$, $\overline{CS6}$ (masked ROM version and ROM less version only) | Output | Chip select 7, 6 | |
| | \overline{RD} | Output | Read | Shows reading from external devices. |
| | \overline{WRHH} (SH7145 only) | Output | Write HH | Shows writing into the HH 8 bits (bits 31 to 24) of the external data. |
| | \overline{WRHL} (SH7145 only) | Output | Write HL | Shows writing into the HL 8 bits (bits 23 to 16) of the external data. |
| | \overline{WRH} | Output | Write upper half | Shows writing into the upper 8 bits (bits 15 to 8) of the external data. |
| | \overline{WRL} | Output | Write lower half | Shows writing into the lower 8 bits (bit7 to bit0) of the external data. |
| | \overline{WAIT} | Input | Wait | Inserts the wait cycles into the bus cycle when accessing the external spaces. |
| Direct memory access controller (DMAC) | $\overline{DREQ0}$, $\overline{DREQ1}$ | Input | DMA transfer request | DMA request input pins from an external device. |
| | DRAK0, DRAK1 | Output | DREQ request acknowledge | Outputs an acknowledge signal to the external device that has input a DMA transfer request signal. |
| | DACK0, DACK1 | Output | DMA transfer strobe | Outputs a strobe to the I/O of the external device that has input a DMA transfer request signal. |

| Type | Symbol | I/O | Name | Function |
|---|------------------|--------------|--|---|
| Multifunction timer-pulse unit (MTU) | TCLKA to TCLKD | Input | External clock input for MTU timer | These pins input an external clock. |
| | TIOC0A to TIOC0D | Input/Output | MTU input capture/output compare (channel 0) | The TGRA_0 to TGRD_0 input capture input/output compare output/PWM output pins. |
| | TIOC1A, TIOC1B | Input/Output | MTU input capture/output compare (channel 1) | The TGRA_1 to TGRB_1 input capture input/output compare output/PWM output pins. |
| | TIOC2A, TIOC2B | Input/Output | MTU input capture/output compare (channel 2) | The TGRA_2 to TGRB_2 input capture input/output compare output/PWM output pins. |
| | TIOC3A to TIOC3D | Input/Output | MTU input capture/output compare (channel 3) | The TGRA_3 to TGRD_3 input capture input/output compare output/PWM output pins. |
| | TIOC4A to TIOC4D | Input/Output | MTU input capture/output compare (channel 4) | The TGRA_4 to TGRB_4 input capture input/output compare output/PWM output pins. |
| Serial communication interface (SCI) | TXD3 to TXD0 | Output | Transmitted data | Data output pins. |
| | RXD3 to RXD0 | Input | Received data | Data input pins. |
| | SCK3 to SCK0 | Input/Output | Serial clock | Clock input/output pins. |
| I ² C bus interface (option) | SCL0 | Input/Output | I ² C clock input/ output | I ² C bus clock input/output pins, which drive a bus. Output a clock in the NMOS open-drain method. |
| | SDA0 | Input/Output | I ² C data input/ output | I ² C bus data input/output pins, which drive a bus. Output data in the NMOS open-drain method. |

| Type | Symbol | I/O | Name | Function |
|------------------------|--|------------------|-------------------------------------|---|
| Output control for MTU | $\overline{\text{POE3}}$ to $\overline{\text{POE0}}$ | Input | Port output control | Input pins for the signal to request the output pins of MTU waveforms to become high impedance state. |
| A/D converter | AN7 to AN0 | Input | Analog input pins | Analog input pins. |
| | $\overline{\text{ADTRG}}$ | Input | Input of trigger for A/D conversion | Pin for input of an external trigger to start A/D conversion |
| | AVref (SH7145 only) | Input | Analog reference power supply | Analog reference power supply pin, (In SH7144, this pin is internally connected to the AVcc pin). |
| | AV _{cc} | Input | Analog power supply | Power supply pin for the A/D converter. When the A/D converter is not used, connect this pin to the system power supply (+3.3 V). |
| | AV _{ss} | Input | Analog ground | The ground pin for the A/D converter. Connect this pin to the system power supply (0 V). |
| I/O port | SH7144 PA15 to PA0 SH7145 PA23 to PA0 | Input/ Output | General purpose port | SH7144: 16-bit general purpose input/output pins. SH7145: 24-bit general purpose input/output pins. |
| | PB9 to PB0 | Input/ Output | General purpose port | 10-bit general purpose input/output pins. |
| | PC15 to PC0 | Input/ Output | General purpose port | 16-bit general purpose input/output pins. |
| | SH7144: PD15 to PD0 SH7145: PD31 to PD0 | Input/ Output | General purpose port | SH7144: 16-bit general purpose input/output pins. SH7145: 32-bit general purpose input/output pins. |
| | PE15 to PE0 | Input/ Output | General purpose port | 16-bit general purpose input/output pins. |
| | PF7 to PF0 | Input | General purpose port | 8-bit general purpose input pins. |

| Type | Symbol | I/O | Name | Function |
|---|------------------------------|--------------|----------------------------|--|
| User debugging interface (H-UDI) (flash version only) | TCK | Input | Test clock | Test clock input pin. |
| | TMS | Input | Test mode select | Test mode select signal input pin. |
| | TDI | Input | Test data input | Instruction/data serial input pin. |
| | TDO | Output | Test data output | Instruction/data serial output pin. |
| | $\overline{\text{TRST}}$ | Input | Test reset | Initialization signal input pin. |
| Advanced user debugger (AUD) (flash version only) | AUDATA3 to AUDATA0 | Input/Output | AUD data | Branch trace mode: Branch destination address output pins. RAM monitor mode: Monitor address input/data input/output pins. |
| | $\overline{\text{AUDRST}}$ | Input | AUD reset | Reset signal input pin. |
| | AUDMD | Input | AUD mode | Mode select signal input pin. Branch trace mode: Low RAM monitor mode: High |
| | AUDCK | Input/Output | AUD clock | Branch trace mode: Synchronous clock output pin. RAM monitor mode: Synchronous clock input pin. |
| | $\overline{\text{AUDSYNC}}$ | Input/Output | AUD synchronization signal | Branch trace mode: Data start position identification signal output pin. RAM monitor mode: Data start position identification signal input pin. |
| E10 interface (flash version only) | $\overline{\text{ASEBRKAK}}$ | Output | Break mode acknowledge | Shows that E10A has entered to the break mode. Refer to "SH7144F E10A Emulator User's Manual" for the detail of the connection to E10A. |
| | DBGMD | Input | Debug mode | Enables the functions of E10A emulator. Input low to the pin in normal operation (other than the debug mode). In debug mode, input high to the pin on the user board. Refer to "SH7144F E10A Emulator User's Manual" for the detail of the connection to E10A. |

[Caution]

Do not pull-down the $\overline{\text{WDTOVF}}$ pin. If this pin needs to be pulled-down, however, the resistor value must be 1 M Ω or higher.

Section 2 CPU

2.1 Features

- General-register architecture
 - Sixteen 32-bit general registers
- Sixty-two basic instructions
- Eleven addressing modes
 - Register direct [Rn]
 - Register indirect [$@Rn$]
 - Register indirect with post-increment [$@Rn+$]
 - Register indirect with pre-decrement [$@-Rn$]
 - Register indirect with displacement [$@disp:4,Rn$]
 - Register indirect with index [$@R0, Rn$]
 - GBR indirect with displacement [$@disp:8,GBR$]
 - GBR indirect with index [$@R0,GBR$]
 - Program-counter relative with displacement [$@disp:8,PC$]
 - Program-counter relative [$disp:8/disp:12/Rn$]
 - Immediate [#imm:8]

2.2 Register Configuration

The register set consists of sixteen 32-bit general registers, three 32-bit control registers, and four 32-bit system registers.

2.2.1 General Registers (Rn)

The sixteen 32-bit general registers (Rn) are numbered R0 to R15. General registers are used for data processing and address calculation. R0 is also used as an index register. Several instructions have R0 fixed as their only usable register. R15 is used as the hardware stack pointer (SP). Saving and recovering the status register (SR) and program counter (PC) in exception processing is accomplished by referencing the stack using R15.

General registers (Rn)



Status register (SR)

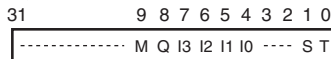

Global base register (GBR)



Vector base register (VBR)

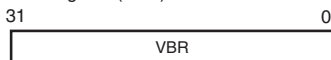

Multiply-accumulate register (MAC)

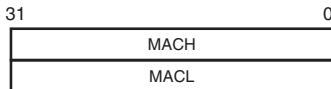

Procedure register

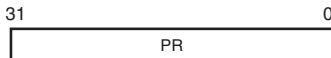

Program counter (PC)

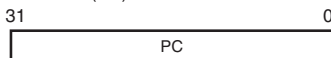

- Notes: 1. R0 functions as an index register in the indirect indexed register addressing mode and indirect indexed GBR addressing mode. In some instructions, R0 functions as a fixed source register or destination register.
 2. R15 functions as a hardware stack pointer (SP) during exception processing.

Figure 2.1 CPU Internal Registers

2.2.2 Control Registers

The control registers consist of three 32-bit registers: status register (SR), global base register (GBR), and vector base register (VBR). The status register indicates processing states. The global base register functions as a base address for the indirect GBR addressing mode to transfer data to the registers of on-chip peripheral modules. The vector base register functions as the base address of the exception processing vector area (including interrupts).

Status Register (SR):

| Bit | Bit Name | Initial Value | R/W | Description |
|----------|----------|---------------|-----|---|
| 31 to 10 | — | All 0 | R/W | Reserved These bits are always read as 0. The write value should always be 0. |
| 9 | M | Undefined | R/W | Used by the DIV0U, DIV0S, and DIV1 instructions. |
| 8 | Q | Undefined | R/W | Used by the DIV0U, DIV0S, and DIV1 instructions. |
| Bit | Bit Name | Initial Value | R/W | Description |
| 7 | I3 | 1 | R/W | Interrupt mask bits. |
| 6 | I2 | 1 | R/W | |
| 5 | I1 | 1 | R/W | |
| 4 | I0 | 1 | R/W | |
| 3, 2 | — | All 0 | R/W | Reserved These bits are always read as 0. The write value should always be 0. |
| 1 | S | Undefined | R/W | S bit Used by the MAC instruction. |
| 0 | T | Undefined | R/W | T bit The MOV _T , CMP/cond, TAS, TST, BT (BT/S), BF (BF/S), SETT, and CLRT instructions use the T bit to indicate true (1) or false (0). The ADDV, ADDC, SUBV, SUBC, DIV0U, DIV0S, DIV1, NEG _C , SHAR, SHAL, SHLR, SHLL, ROTR, ROTL, ROTCR, and ROTCL instructions also use the T bit to indicate carry/borrow or overflow/underflow. |

Global Base Register (GBR): Indicates the base address of the indirect GBR addressing mode. The indirect GBR addressing mode is used in data transfer for on-chip peripheral modules register areas and in logic operations.

Vector Base Register (VBR): Indicates the base address of the exception processing vector area.

2.2.3 System Registers

System registers consist of four 32-bit registers: high and low multiply and accumulate registers (MACH and MACL), the procedure register (PR), and the program counter (PC).

Multiply-and-Accumulate Registers (MAC): Registers to store the results of multiply-and-accumulate operations.

Procedure Register (PR): Registers to store the return address from a subroutine procedure.

Program Counter (PC): Registers to indicate the sum of current instruction addresses and four, that is, the address of the second instruction after the current instruction.

2.2.4 Initial Values of Registers

Table 2.1 lists the values of the registers after reset.

Table 2.1 Initial Values of Registers

| Classification | Register | Initial Value |
|-------------------|----------------|---|
| General registers | R0 to R14 | Undefined |
| | R15 (SP) | Value of the stack pointer in the vector address table |
| Control registers | SR | Bits I3 to I0 are 1111 (H'F), reserved bits are 0, and other bits are undefined |
| | GBR | Undefined |
| | VBR | H'00000000 |
| System registers | MACH, MACL, PR | Undefined |
| | PC | Value of the program counter in the vector address table |

2.3 Data Formats

2.3.1 Data Format in Registers

Register operands are always longwords (32 bits). If the size of memory operand is a byte (8 bits) or a word (16 bits), it is changed into a longword by expanding the sign-part when loaded into a register.

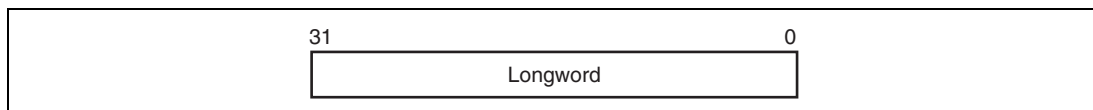

Figure 2.2 Data Format in Registers

2.3.2 Data Formats in Memory

Memory data formats are classified into bytes, words, and longwords. Byte data can be accessed from any address. Locate, however, word data at an address $2n$, longword data at $4n$. Otherwise, an address error will occur if an attempt is made to access word data starting from an address other than $2n$ or longword data starting from an address other than $4n$. In such cases, the data accessed cannot be guaranteed. The hardware stack area, pointed by the hardware stack pointer (SP, R15), uses only longword data starting from address $4n$ because this area holds the program counter and status register.

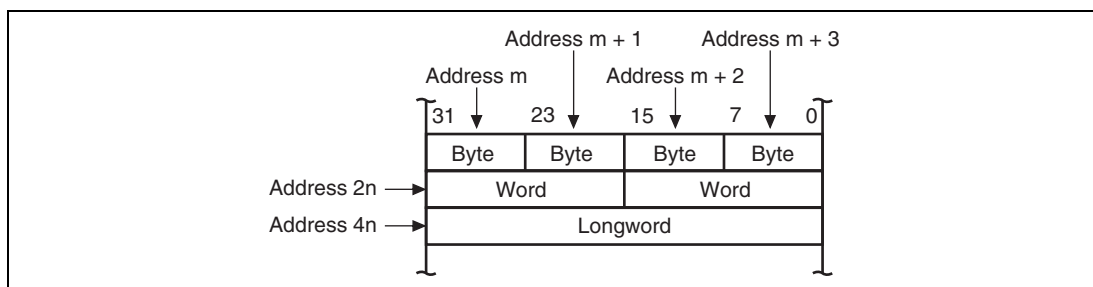

Figure 2.3 Data Formats in Memory

2.3.3 Immediate Data Format

Byte (8 bit) immediate data resides in an instruction code. Immediate data accessed by the MOV, ADD, and CMP/EQ instructions is sign-extended and handled in registers as longword data. Immediate data accessed by the TST, AND, OR, and XOR instructions is zero-extended and handled as longword data. Consequently, AND instructions with immediate data always clear the upper 24 bits of the destination register.

Word or longword immediate data is not located in the instruction code, but instead is stored in a memory table. An immediate data transfer instruction (MOV) accesses the memory table using the PC relative addressing mode with displacement.

2.4 Instruction Features

2.4.1 RISC-Type Instruction Set

All instructions are RISC type. This section details their functions.

16-Bit Fixed Length: All instructions are 16 bits long, increasing program code efficiency.

One Instruction per State: The microcomputer can execute basic instructions in one state using the pipeline system. One state is 25 ns at 40 MHz.

Data Length: Longword is the standard data length for all operations. Memory can be accessed in bytes, words, or longwords. Byte or word data accessed from memory is sign-extended and handled as longword data. Immediate data is sign-extended for arithmetic operations or zero-extended for logic operations. It also is handled as longword data.

Table 2.2 Sign Extension of Word Data

| CPU of This LSI | Description | Example of Conventional CPU |
|------------------------|--|-----------------------------|
| MOV.W @ (disp, PC), R1 | Data is sign-extended to 32 bits, and R1 becomes | ADD.W #H'1234, R0 |
| ADD R1, R0 | H'00001234. It is next | |
| | operated upon by an ADD | |
| .DATA.W H'1234 | instruction. | |

Note: @ (disp, PC) accesses the immediate data.

Load-Store Architecture: Basic operations are executed between registers. For operations that involve memory access, data is loaded to the registers and executed (load-store architecture). Instructions such as AND that manipulate bits, however, are executed directly in memory.

Delayed Branch Instructions: Unconditional branch instructions are delayed branch instructions. With a delayed branch instruction, the branch is taken after execution of the instruction following the delayed branch instruction. This reduces the disturbance of the pipeline control in case of branch instructions. There are two types of conditional branch instructions: delayed branch instructions and ordinary branch instructions.

Table 2.3 Delayed Branch Instructions

| CPU of This LSI | | Description | Example of Conventional CPU | |
|-----------------|--------|---|-----------------------------|--------|
| BRA | TRGET | Executes the ADD before branching to TRGET. | ADD.W | R1, R0 |
| ADD | R1, R0 | | BRA | TRGET |

Multiply/Multiply-and-Accumulate Operations: 16-bit \times 16-bit \rightarrow 32-bit multiply operations are executed in one and two states. 16-bit \times 16-bit + 64-bit \rightarrow 64-bit multiply-and-accumulate operations are executed in two and three states. 32-bit \times 32-bit \rightarrow 64-bit multiply and 32-bit \times 32-bit + 64-bit \rightarrow 64-bit multiply-and-accumulate operations are executed in two to four states.

T Bit: The T bit in the status register changes according to the result of the comparison. Whether a conditional branch is taken or not taken depends upon the T bit condition (true/false). The number of instructions that change the T bit is kept to a minimum to improve the processing speed.

Table 2.4 T Bit

| CPU of This LSI | | Description | Example of Conventional CPU | |
|-----------------|---------|--|-----------------------------|--------|
| CMP/GE | R1, R0 | T bit is set when $R0 \geq R1$. The program branches to TRGET0 when $R0 \geq R1$ and to TRGET1 when $R0 < R1$. | CMP.W | R1, R0 |
| BT | TRGET0 | | BGE | TRGET0 |
| BF | TRGET1 | | BLT | TRGET1 |
| ADD | #-1, R0 | T bit is not changed by ADD. T bit is set when $R0 = 0$. The program branches if $R0 = 0$. | SUB.W | #1, R0 |
| CMP/EQ | #0, R0 | | BEQ | TRGET |
| BT | TRGET | | | |

Immediate Data: Byte (8-bit) immediate data is located in an instruction code. Word or longword immediate data is not located in instruction codes but in a memory table. An immediate data transfer instruction (MOV) accesses the memory table using the PC relative addressing mode with displacement.

Table 2.5 Immediate Data Accessing

| Classification | CPU of This LSI | | Example of Conventional CPU |
|------------------|-----------------|--|-----------------------------|
| 8-bit immediate | MOV | #H'12,R0 | MOV.B #H'12,R0 |
| 16-bit immediate | MOV.W | @(disp,PC),R0DATA.W H'1234 | MOV.W #H'1234,R0 |
| 32-bit immediate | MOV.L | @(disp,PC),R0DATA.L H'12345678 | MOV.L #H'12345678,R0 |

Note: @(disp,PC) accesses the immediate data.

Absolute Address: When data is accessed by absolute address, the value in the absolute address is placed in the memory table in advance. That value is transferred to the register by loading the immediate data during the execution of the instruction, and the data is accessed in the indirect register addressing mode.

Table 2.6 Absolute Address Accessing

| Classification | CPU of This LSI | | Example of Conventional CPU |
|------------------|-----------------|-----------------------------|-----------------------------|
| Absolute address | MOV.L | @(disp,PC),R1 | MOV.B @H'12345678,R0 |
| | MOV.B | @R1,R0 | |
| | |DATA.L H'12345678 | |

Note: @(disp,PC) accesses the immediate data.

16-Bit/32-Bit Displacement: When data is accessed by 16-bit or 32-bit displacement, the displacement value is placed in the memory table in advance. That value is transferred to the register by loading the immediate data during the execution of the instruction, and the data is accessed in the indirect indexed register addressing mode.

Table 2.7 Displacement Accessing

| Classification | CPU of This LSI | Example of Conventional CPU |
|-----------------------|-------------------------|------------------------------------|
| 16-bit displacement | MOV.W @ (disp, PC) , R0 | MOV.W @ (H' 1234, R1) , R2 |
| | MOV.W @ (R0, R1) , R2 | |
| | | |
| | .DATA.W H' 1234 | |

Note: @ (disp,PC) accesses the immediate data.

2.4.2 Addressing Modes

Table 2.8 describes addressing modes and effective address calculation.

Table 2.8 Addressing Modes and Effective Addresses

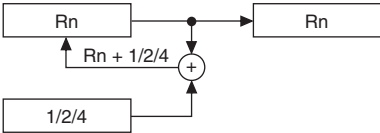
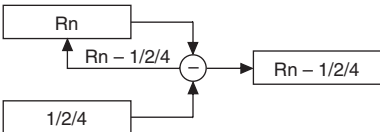
| Addressing Mode | Instruction Format | Effective Address Calculation | Equation |
|---|--------------------|---|--|
| Direct register addressing | Rn | The effective address is register Rn. (The operand is the contents of register Rn.) | — |
| Indirect register addressing | @Rn | The effective address is the contents of register Rn.  | Rn |
| Post-increment indirect register addressing | @Rn+ | The effective address is the contents of register Rn. A constant is added to the content of Rn after the instruction is executed. 1 is added for a byte operation, 2 for a word operation, and 4 for a longword operation.  | Rn (After the instruction executes) Byte: $Rn + 1 \rightarrow Rn$ Word: $Rn + 2 \rightarrow Rn$ Longword: $Rn + 4 \rightarrow Rn$ |
| Pre-decrement indirect register addressing | @-Rn | The effective address is the value obtained by subtracting a constant from Rn. 1 is subtracted for a byte operation, 2 for a word operation, and 4 for a longword operation.  | Byte: $Rn - 1 \rightarrow Rn$ Word: $Rn - 2 \rightarrow Rn$ Longword: $Rn - 4 \rightarrow Rn$ (Instruction is executed with Rn after this calculation) |

| Addressing Mode | Instruction Format | Effective Address Calculation | Equation |
|--|--------------------|--|---|
| Indirect register addressing with displacement | @(disp:4, Rn) | The effective address is the sum of Rn and a 4-bit displacement (disp). The value of disp is zero-extended, and remains unchanged for a byte operation, is doubled for a word operation, and is quadrupled for a longword operation. | Byte: Rn + disp Word: Rn + disp × 2 Longword: Rn + disp × 4 |
| | | | |
| Indirect indexed register addressing | @(R0, Rn) | The effective address is the sum of Rn and R0. | Rn + R0 |
| | | | |
| Indirect GBR addressing with displacement | @(disp:8, GBR) | The effective address is the sum of GBR value and an 8-bit displacement (disp). The value of disp is zero-extended, and remains unchanged for a byte operation, is doubled for a word operation, and is quadrupled for a longword operation. | Byte: GBR + disp Word: GBR + disp × 2 Longword: GBR + disp × 4 |
| | | | |
| Indirect indexed GBR addressing | @(R0, GBR) | The effective address is the sum of GBR value and R0. | GBR + R0 |
| | | | |

| Addressing Mode | Instruction Format | Effective Address Calculation | Equation |
|--|--------------------|--|--|
| Indirect PC addressing with displacement | @(disp:8, PC) | The effective address is the sum of PC value and an 8-bit displacement (disp). The value of disp is zero-extended, and is doubled for a word operation, and quadrupled for a longword operation. For a longword operation, the lowest two bits of the PC value are masked. | Word: $PC + disp \times 2$ Longword: $PC \& H'FFFFFFFC + disp \times 4$ |
| | | | |
| PC relative addressing | disp:8 | The effective address is the sum of PC value and the value that is obtained by doubling the sign-extended 8-bit displacement (disp). | $PC + disp \times 2$ |
| | | | |
| | disp:12 | The effective address is the sum of PC value and the value that is obtained by doubling the sign-extended 12-bit displacement (disp). | $PC + disp \times 2$ |
| | | | |
| | Rn | The effective address is the sum of the register PC and Rn. | $PC + Rn$ |
| | | | |

| Addressing Mode | Instruction Format | Effective Address Calculation | Equation |
|------------------------|---------------------------|--|-----------------|
| Immediate addressing | #imm:8 | The 8-bit immediate data (imm) for the TST, AND, OR, and XOR instructions is zero-extended. | — |
| | #imm:8 | The 8-bit immediate data (imm) for the MOV, ADD, and CMP/EQ instructions is sign-extended. | — |
| | #imm:8 | The 8-bit immediate data (imm) for the TRAPA instruction is zero-extended and then quadrupled. | — |

2.4.3 Instruction Format

The instruction formats and the meaning of source and destination operand are described below. The meaning of the operand depends on the instruction code. The symbols used are as follows:

- xxxx: Instruction code
- mmmm: Source register
- nnnn: Destination register
- iiiii: Immediate data
- dddd: Displacement

Table 2.9 Instruction Formats

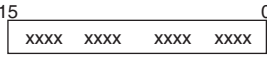
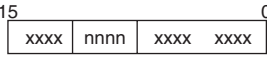
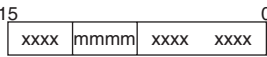
| Instruction Formats | Source Operand | Destination Operand | Example |
|---|--|---------------------------------------|----------------|
| 0 format  | — | — | NOF |
| n format  | — | nnnn: Direct register | MOVT Rn |
| | Control register or system register | nnnn: Direct register | STS MACH, Rn |
| | Control register or system register | nnnn: Indirect pre-decrement register | STC.L SR, @-Rn |
| m format  | mmmm: Direct register | Control register or system register | LDC Rm, SR |
| | mmmm: Indirect post-increment register | Control register or system register | LDC.L @Rm+, SR |
| | mmmm: Indirect register | — | JMP @Rm |
| | mmmm: PC relative using Rm | — | BRAF Rm |

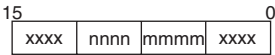
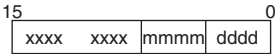
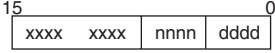
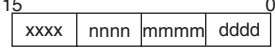
| Instruction Formats | Source Operand | Destination Operand | Example |
|--|---|---|-----------------------|
| nm format | mmmm: Direct register | nnnn: Direct register | ADD Rm, Rn |
|  | mmmm: Direct register | nnnn: Indirect register | MOV.L Rm, @Rn |
| | mmmm: Indirect post-increment register (multiply-and-accumulate) | MACH, MACL | MAC.W @Rm+, @Rn+ |
| | nnnn*: Indirect post-increment register (multiply-and-accumulate) | | |
| | mmmm: Indirect post-increment register | nnnn: Direct register | MOV.L @Rm+, Rn |
| | mmmm: Direct register | nnnn: Indirect pre-decrement register | MOV.L Rm, @-Rn |
| | mmmm: Direct register | nnnn: Indirect indexed register | MOV.L Rm, @(R0, Rn) |
| md format | mmmmdddd: Indirect register with displacement | R0 (Direct register) | MOV.B @(disp, Rn), R0 |
|  | R0 (Direct register) | nnnndddd: Indirect register with displacement | MOV.B R0, @(disp, Rn) |
| nd4 format | | | |
|  | | | |
| nmd format | mmmm: Direct register | nnnndddd: Indirect register with displacement | MOV.L Rm, @(disp, Rn) |
|  | mmmmdddd: Indirect register with displacement | nnnn: Direct register | MOV.L @(disp, Rm), Rn |

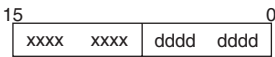
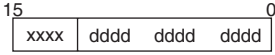
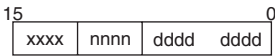
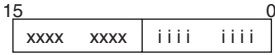
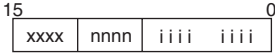
| Instruction Formats | Source Operand | Destination Operand | Example |
|---|---|---|---------------------------------------|
| d format  | ddddddd: Indirect GBR with displacement | R0 (Direct register) | MOV.L @(disp,GBR),R0 |
| | R0 (Direct register) | ddddddd: Indirect GBR with displacement | MOV.L R0,@(disp,GBR) |
| | ddddddd: PC relative with displacement | R0 (Direct register) | MOVA @(disp,PC),R0 |
| | — | ddddddd: PC relative | BF label |
| d12 format  | — | ddddddddddd: PC relative | BRA label (label = disp + PC) |
| nd8 format  | ddddddd: PC relative with displacement | nnnn: Direct register | MOV.L @(disp,PC),Rn |
| i format  | iiiiiii: Immediate | Indirect indexed GBR | AND.B #imm,@(R0,GBR) |
| | iiiiiii: Immediate | R0 (Direct register) | AND #imm,R0 |
| | iiiiiii: Immediate | — | TRAPA #imm |
| ni format  | iiiiiii: Immediate | nnnn: Direct register | ADD #imm,Rn |

Note: In multiply-and-accumulate instructions, nnnn is the source register.

2.5 Instruction Set

2.5.1 Instruction Set by Classification

Table 2.10 lists the instructions according to their classification.

Table 2.10 Classification of Instructions

| Classification | Types | Operation Code | Function | No. of Instructions |
|-----------------------|--------------------|-----------------------|--|----------------------------|
| Data transfer | 5 | MOV | Data transfer, immediate data transfer, peripheral module data transfer, structure data transfer | 39 |
| | | MOVA | Effective address transfer | |
| | | MOVT | T bit transfer | |
| | | SWAP | Swap of upper and lower bytes | |
| | | XTRCT | Extraction of the middle of registers connected | |
| Arithmetic operations | 21 | ADD | Binary addition | 33 |
| | | ADDC | Binary addition with carry | |
| | | ADDV | Binary addition with overflow check | |
| | | CMP/cond | Comparison | |
| | | DIV1 | Division | |
| | | DIV0S | Initialization of signed division | |
| | | DIV0U | Initialization of unsigned division | |
| | | DMULS | Signed double-length multiplication | |
| | | DMULU | Unsigned double-length multiplication | |
| | | DT | Decrement and test | |
| | | EXTS | Sign extension | |
| | | EXTU | Zero extension | |
| | | MAC | Multiply-and-accumulate, double-length multiply-and-accumulate operation | |
| | | MUL | Double-length multiply operation | |
| | | MULS | Signed multiplication | |
| | | MULU | Unsigned multiplication | |
| | | NEG | Negation | |
| | | NEGC | Negation with borrow | |
| SUB | Binary subtraction | | | |

| Classification | Types | Operation | | No. of Instructions |
|-----------------------|-------|-----------|---|---------------------|
| | | Code | Function | |
| Arithmetic operations | | SUBC | Binary subtraction with borrow | 33 |
| | | SUBV | Binary subtraction with underflow | |
| Logic operations | 6 | AND | Logical AND | 14 |
| | | NOT | Bit inversion | |
| | | OR | Logical OR | |
| | | TAS | Memory test and bit set | |
| | | TST | Logical AND and T bit set | |
| | | XOR | Exclusive OR | |
| Shift | 10 | ROTL | One-bit left rotation | 14 |
| | | ROTR | One-bit right rotation | |
| | | ROTCL | One-bit left rotation with T bit | |
| | | ROTCR | One-bit right rotation with T bit | |
| | | SHAL | One-bit arithmetic left shift | |
| | | SHAR | One-bit arithmetic right shift | |
| | | SHLL | One-bit logical left shift | |
| | | SHLLn | n-bit logical left shift | |
| | | SHLR | One-bit logical right shift | |
| | | SHLRn | n-bit logical right shift | |
| Branch | 9 | BF | Conditional branch, conditional branch with delay (Branch when T = 0) | 11 |
| | | BT | Conditional branch, conditional branch with delay (Branch when T = 1) | |
| | | BRA | Unconditional branch | |
| | | BRAF | Unconditional branch | |
| | | BSR | Branch to subroutine procedure | |
| | | BSRF | Branch to subroutine procedure | |
| | | JMP | Unconditional branch | |
| | | JSR | Branch to subroutine procedure | |
| | | RTS | Return from subroutine procedure | |

2. CPU

| Classification | Types | Operation | | No. of Instructions |
|----------------|-------|-----------|----------------------------------|---------------------|
| | | Code | Function | |
| System control | 11 | CLRT | T bit clear | 31 |
| | | CLRMAC | MAC register clear | |
| | | LDC | Load to control register | |
| | | LDS | Load to system register | |
| | | NOP | No operation | |
| | | RTE | Return from exception processing | |
| | | SETT | T bit set | |
| | | SLEEP | Transition to power-down mode | |
| | | STC | Store control register data | |
| | | STS | Store system register data | |
| | | TRAPA | Trap exception handling | |
| Total: | 62 | | | 142 |

The table below shows the format of instruction codes, operation, and execution states. They are described by using this format according to their classification.

- Instruction Code Format

| Item | Format | Explanation |
|--------------------------|--|--|
| Instruction | Described in mnemonic. OP.Sz SRC,DEST | OP: Operation code Sz: Size SRC: Source DEST: Destination Rm: Source register Rn: Destination register imm: Immediate data disp: Displacement* ² |
| Instruction code | Described in MSB ↔ LSB order | mmmm: Source register nnnn: Destination register 0000: R0 0001: R1 . . 1111: R15 iiii: Immediate data dddd: Displacement |
| Outline of the Operation | →, ← | Direction of transfer |
| | (xx) | Memory operand |
| | M/Q/T | Flag bits in the SR |
| | & | Logical AND of each bit |
| | | Logical OR of each bit |
| | ^ | Exclusive OR of each bit |
| | ~ | Logical NOT of each bit |
| | <<n >>n | n-bit left shift n-bit right shift |
| Execution states | — | Value when no wait states are inserted* ¹ |
| T bit | — | Value of T bit after instruction is executed. An em-dash (—) in the column means no change. |

- Notes: 1. Instruction execution states: The execution states shown in the table are minimums. The actual number of states may be increased when (1) contention occurs between instruction fetches and data access, or (2) when the destination register of the load instruction (memory → register) equals to the register used by the next instruction.
2. Depending on the operand size, displacement is scaled by ×1, ×2, or ×4. For details, refer the SH-1/SH-2/SH-DSP Software Manual.

• Data Transfer Instructions

| Instruction | Instruction Code | Operation | Execution States | T Bit |
|-----------------------|------------------|---|------------------|-------|
| MOV #imm, Rn | 1110nnnniiiiiiii | #imm → Sign extension → Rn | 1 | — |
| MOV.W @(disp, PC), Rn | 1001nnnnddddddd | (disp × 2 + PC) → Sign extension → Rn | 1 | — |
| MOV.L @(disp, PC), Rn | 1101nnnnddddddd | (disp × 4 + PC) → Rn | 1 | — |
| MOV Rm, Rn | 0110nnnnmmmm0011 | Rm → Rn | 1 | — |
| MOV.B Rm, @Rn | 0010nnnnmmmm0000 | Rm → (Rn) | 1 | — |
| MOV.W Rm, @Rn | 0010nnnnmmmm0001 | Rm → (Rn) | 1 | — |
| MOV.L Rm, @Rn | 0010nnnnmmmm0010 | Rm → (Rn) | 1 | — |
| MOV.B @Rm, Rn | 0110nnnnmmmm0000 | (Rm) → Sign extension → Rn | 1 | — |
| MOV.W @Rm, Rn | 0110nnnnmmmm0001 | (Rm) → Sign extension → Rn | 1 | — |
| MOV.L @Rm, Rn | 0110nnnnmmmm0010 | (Rm) → Rn | 1 | — |
| MOV.B Rm, @-Rn | 0010nnnnmmmm0100 | Rn-1 → Rn, Rm → (Rn) | 1 | — |
| MOV.W Rm, @-Rn | 0010nnnnmmmm0101 | Rn-2 → Rn, Rm → (Rn) | 1 | — |
| MOV.L Rm, @-Rn | 0010nnnnmmmm0110 | Rn-4 → Rn, Rm → (Rn) | 1 | — |
| MOV.B @Rm+, Rn | 0110nnnnmmmm0100 | (Rm) → Sign extension → Rn, Rm + 1 → Rm | 1 | — |
| MOV.W @Rm+, Rn | 0110nnnnmmmm0101 | (Rm) → Sign extension → Rn, Rm + 2 → Rm | 1 | — |
| MOV.L @Rm+, Rn | 0110nnnnmmmm0110 | (Rm) → Rn, Rm + 4 → Rm | 1 | — |
| MOV.B R0, @(disp, Rn) | 10000000nnnnddd | R0 → (disp + Rn) | 1 | — |
| MOV.W R0, @(disp, Rn) | 10000001nnnnddd | R0 → (disp × 2 + Rn) | 1 | — |
| MOV.L Rm, @(disp, Rn) | 0001nnnnmmmmddd | Rm → (disp × 4 + Rn) | 1 | — |
| MOV.B @(disp, Rm), R0 | 10000100mmmmddd | (disp + Rm) → Sign extension → R0 | 1 | — |
| MOV.W @(disp, Rm), R0 | 10000101mmmmddd | (disp × 2 + Rm) → Sign extension → R0 | 1 | — |
| MOV.L @(disp, Rm), Rn | 0101nnnnmmmmddd | (disp × 4 + Rm) → Rn | 1 | — |
| MOV.B Rm, @(R0, Rn) | 0000nnnnmmmm0100 | Rm → (R0 + Rn) | 1 | — |
| MOV.W Rm, @(R0, Rn) | 0000nnnnmmmm0101 | Rm → (R0 + Rn) | 1 | — |
| MOV.L Rm, @(R0, Rn) | 0000nnnnmmmm0110 | Rm → (R0 + Rn) | 1 | — |

| Instruction | Instruction Code | Operation | Execution States | T Bit |
|------------------------|------------------|--|------------------|-------|
| MOV.B @(R0, Rm), Rn | 0000nnnnmmmm1100 | (R0 + Rm) → Sign extension → Rn | 1 | — |
| MOV.W @(R0, Rm), Rn | 0000nnnnmmmm1101 | (R0 + Rm) → Sign extension → Rn | 1 | — |
| MOV.L @(R0, Rm), Rn | 0000nnnnmmmm1110 | (R0 + Rm) → Rn | 1 | — |
| MOV.B R0, @(disp, GBR) | 11000000ddddddd | R0 → (disp + GBR) | 1 | — |
| MOV.W R0, @(disp, GBR) | 11000001ddddddd | R0 → (disp × 2 + GBR) | 1 | — |
| MOV.L R0, @(disp, GBR) | 11000010ddddddd | R0 → (disp × 4 + GBR) | 1 | — |
| MOV.B @(disp, GBR), R0 | 11000100ddddddd | (disp + GBR) → Sign extension → R0 | 1 | — |
| MOV.W @(disp, GBR), R0 | 11000101ddddddd | (disp × 2 + GBR) → Sign extension → R0 | 1 | — |
| MOV.L @(disp, GBR), R0 | 11000110ddddddd | (disp × 4 + GBR) → R0 | 1 | — |
| MOVA @(disp, PC), R0 | 11000111ddddddd | disp × 4 + PC → R0 | 1 | — |
| MOVT Rn | 0000nnnn00101001 | T → Rn | 1 | — |
| SWAP.B Rm, Rn | 0110nnnnmmmm1000 | Rm → Swap bottom two bytes → Rn | 1 | — |
| SWAP.W Rm, Rn | 0110nnnnmmmm1001 | Rm → Swap two consecutive words → Rn | 1 | — |
| XTRCT Rm, Rn | 0010nnnnmmmm1101 | Rm: Middle 32 bits of Rn → Rn | 1 | — |

2. CPU

- Arithmetic Operation Instructions

| Instruction | Instruction Code | Operation | Execution States | T Bit |
|-----------------|------------------|---|------------------|--------------------|
| ADD Rm, Rn | 0011nnnnmmmm1100 | $Rn + Rm \rightarrow Rn$ | 1 | — |
| ADD #imm, Rn | 0111nnnniiiiiii | $Rn + imm \rightarrow Rn$ | 1 | — |
| ADDC Rm, Rn | 0011nnnnmmmm1110 | $Rn + Rm + T \rightarrow Rn$, Carry $\rightarrow T$ | 1 | Carry |
| ADDV Rm, Rn | 0011nnnnmmmm1111 | $Rn + Rm \rightarrow Rn$, Overflow $\rightarrow T$ | 1 | Overflow |
| CMP/EQ #imm, R0 | 10001000iiiiiii | If $R0 = imm$, $1 \rightarrow T$ | 1 | Comparison result |
| CMP/EQ Rm, Rn | 0011nnnnmmmm0000 | If $Rn = Rm$, $1 \rightarrow T$ | 1 | Comparison result |
| CMP/HS Rm, Rn | 0011nnnnmmmm0010 | If $Rn \geq Rm$ with unsigned data, $1 \rightarrow T$ | 1 | Comparison result |
| CMP/GE Rm, Rn | 0011nnnnmmmm0011 | If $Rn \geq Rm$ with signed data, $1 \rightarrow T$ | 1 | Comparison result |
| CMP/HI Rm, Rn | 0011nnnnmmmm0110 | If $Rn > Rm$ with unsigned data, $1 \rightarrow T$ | 1 | Comparison result |
| CMP/GT Rm, Rn | 0011nnnnmmmm0111 | If $Rn > Rm$ with signed data, $1 \rightarrow T$ | 1 | Comparison result |
| CMP/PL Rn | 0100nnnn00010101 | If $Rn > 0$, $1 \rightarrow T$ | 1 | Comparison result |
| CMP/PZ Rn | 0100nnnn00010001 | If $Rn \geq 0$, $1 \rightarrow T$ | 1 | Comparison result |
| CMP/STR Rm, Rn | 0010nnnnmmmm1100 | If Rn and Rm have an equivalent byte, $1 \rightarrow T$ | 1 | Comparison result |
| DIV1 Rm, Rn | 0011nnnnmmmm0100 | Single-step division ($Rn \div Rm$) | 1 | Calculation result |
| DIV0S Rm, Rn | 0010nnnnmmmm0111 | MSB of $Rn \rightarrow Q$, MSB of $Rm \rightarrow M$, $M \wedge Q \rightarrow T$ | 1 | Calculation result |
| DIV0U | 0000000000011001 | $0 \rightarrow M/Q/T$ | 1 | 0 |
| DMULS.L Rm, Rn | 0011nnnnmmmm1101 | Signed operation of $Rn \times Rm \rightarrow MACH, MACL$ $32 \times 32 \rightarrow 64$ bits | 2 to 4* | — |
| DMULU.L Rm, Rn | 0011nnnnmmmm0101 | Unsigned operation of $Rn \times Rm \rightarrow MACH, MACL$ $32 \times 32 \rightarrow 64$ bits | 2 to 4* | — |

| Instruction | | Instruction Code | Operation | Execution States | T Bit |
|-------------|------------|------------------|---|------------------|-------------------|
| DT | Rn | 0100nnnn00010000 | $Rn - 1 \rightarrow Rn$, when Rn is 0, $1 \rightarrow T$. When Rn is nonzero, $0 \rightarrow T$ | 1 | Comparison result |
| EXTS.B | Rm, Rn | 0110nnnnmmmm1110 | Byte in Rm is sign-extended $\rightarrow Rn$ | 1 | — |
| EXTS.W | Rm, Rn | 0110nnnnmmmm1111 | Word in Rm is sign-extended $\rightarrow Rn$ | 1 | — |
| EXTU.B | Rm, Rn | 0110nnnnmmmm1100 | Byte in Rm is zero-extended $\rightarrow Rn$ | 1 | — |
| EXTU.W | Rm, Rn | 0110nnnnmmmm1101 | Word in Rm is zero-extended $\rightarrow Rn$ | 1 | — |
| MAC.L | @Rm+, @Rn+ | 0000nnnnmmmm1111 | Signed operation of $(Rn) \times (Rm) + MAC \rightarrow MAC$ $32 \times 32 + 64 \rightarrow 64$ bits | 3/(2 to 4)* | — |
| MAC.W | @Rm+, @Rn+ | 0100nnnnmmmm1111 | Signed operation of $(Rn) \times (Rm) + MAC \rightarrow MAC$ $16 \times 16 + 64 \rightarrow 64$ bits | 3/(2)* | — |
| MUL.L | Rm, Rn | 0000nnnnmmmm0111 | $Rn \times Rm \rightarrow MACL$, $32 \times 32 \rightarrow 32$ bits | 2 to 4* | — |
| MULS.W | Rm, Rn | 0010nnnnmmmm1111 | Signed operation of $Rn \times Rm \rightarrow MACL$ $16 \times 16 \rightarrow 32$ bits | 1 to 3* | — |
| MULU.W | Rm, Rn | 0010nnnnmmmm1110 | Unsigned operation of $Rn \times Rm \rightarrow MACL$ $16 \times 16 \rightarrow 32$ bits | 1 to 3* | — |
| NEG | Rm, Rn | 0110nnnnmmmm1011 | $0 - Rm \rightarrow Rn$ | 1 | — |
| NEGC | Rm, Rn | 0110nnnnmmmm1010 | $0 - Rm - T \rightarrow Rn$, Borrow $\rightarrow T$ | 1 | Borrow |
| SUB | Rm, Rn | 0011nnnnmmmm1000 | $Rn - Rm \rightarrow Rn$ | 1 | — |
| SUBC | Rm, Rn | 0011nnnnmmmm1010 | $Rn - Rm - T \rightarrow Rn$, Borrow $\rightarrow T$ | 1 | Borrow |
| SUBV | Rm, Rn | 0011nnnnmmmm1011 | $Rn - Rm \rightarrow Rn$, Underflow $\rightarrow T$ | 1 | Overflow |

Note: * The normal number of execution states is shown. (The number in parentheses is the number of states when there is contention with the preceding or following instructions.)

- Logic Operation Instructions

| Instruction | Instruction Code | Operation | Execution States | T Bit |
|------------------------|------------------|---|------------------|-------------|
| AND Rm, Rn | 0010nnnnmmmm1001 | $Rn \& Rm \rightarrow Rn$ | 1 | — |
| AND #imm, R0 | 11001001iiiiiii | $R0 \& imm \rightarrow R0$ | 1 | — |
| AND.B #imm, @(R0, GBR) | 11001101iiiiiii | $(R0 + GBR) \& imm \rightarrow (R0 + GBR)$ | 3 | — |
| NOT Rm, Rn | 0110nnnnmmmm0111 | $\sim Rm \rightarrow Rn$ | 1 | — |
| OR Rm, Rn | 0010nnnnmmmm1011 | $Rn Rm \rightarrow Rn$ | 1 | — |
| OR #imm, R0 | 11001011iiiiiii | $R0 imm \rightarrow R0$ | 1 | — |
| OR.B #imm, @(R0, GBR) | 11001111iiiiiii | $(R0 + GBR) imm \rightarrow (R0 + GBR)$ | 3 | — |
| TAS.B @Rn | 0100nnnn00011011 | If (Rn) is 0, $1 \rightarrow T$; $1 \rightarrow$ MSB of (Rn) | 4 | Test result |
| TST Rm, Rn | 0010nnnnmmmm1000 | $Rn \& Rm$; if the result is 0, $1 \rightarrow T$ | 1 | Test result |
| TST #imm, R0 | 11001000iiiiiii | $R0 \& imm$; if the result is 0, $1 \rightarrow T$ | 1 | Test result |
| TST.B #imm, @(R0, GBR) | 11001100iiiiiii | $(R0 + GBR) \& imm$; if the result is 0, $1 \rightarrow T$ | 3 | Test result |
| XOR Rm, Rn | 0010nnnnmmmm1010 | $Rn \wedge Rm \rightarrow Rn$ | 1 | — |
| XOR #imm, R0 | 11001010iiiiiii | $R0 \wedge imm \rightarrow R0$ | 1 | — |
| XOR.B #imm, @(R0, GBR) | 11001110iiiiiii | $(R0 + GBR) \wedge imm \rightarrow (R0 + GBR)$ | 3 | — |

- Shift Instructions

| Instruction | | Instruction Code | Operation | Execution States | T Bit |
|-------------|----|------------------|---|------------------|-------|
| ROTL | Rn | 0100nnnn00000100 | $T \leftarrow Rn \leftarrow \text{MSB}$ | 1 | MSB |
| ROTR | Rn | 0100nnnn00000101 | $\text{LSB} \rightarrow Rn \rightarrow T$ | 1 | LSB |
| ROTCL | Rn | 0100nnnn00100100 | $T \leftarrow Rn \leftarrow T$ | 1 | MSB |
| ROTCR | Rn | 0100nnnn00100101 | $T \rightarrow Rn \rightarrow T$ | 1 | LSB |
| SHAL | Rn | 0100nnnn00100000 | $T \leftarrow Rn \leftarrow 0$ | 1 | MSB |
| SHAR | Rn | 0100nnnn00100001 | $\text{MSB} \rightarrow Rn \rightarrow T$ | 1 | LSB |
| SHLL | Rn | 0100nnnn00000000 | $T \leftarrow Rn \leftarrow 0$ | 1 | MSB |
| SHLR | Rn | 0100nnnn00000001 | $0 \rightarrow Rn \rightarrow T$ | 1 | LSB |
| SHLL2 | Rn | 0100nnnn00001000 | $Rn \ll 2 \rightarrow Rn$ | 1 | — |
| SHLR2 | Rn | 0100nnnn00001001 | $Rn \gg 2 \rightarrow Rn$ | 1 | — |
| SHLL8 | Rn | 0100nnnn00011000 | $Rn \ll 8 \rightarrow Rn$ | 1 | — |
| SHLR8 | Rn | 0100nnnn00011001 | $Rn \gg 8 \rightarrow Rn$ | 1 | — |
| SHLL16 | Rn | 0100nnnn00101000 | $Rn \ll 16 \rightarrow Rn$ | 1 | — |
| SHLR16 | Rn | 0100nnnn00101001 | $Rn \gg 16 \rightarrow Rn$ | 1 | — |

- Branch Instructions

| Instruction | Instruction Code | Operation | Execution States | T Bit |
|-------------|------------------|---|------------------|-------|
| BF label | 10001011dddddddd | If T = 0, disp × 2 + PC → PC; if T = 1, nop | 3/1* | — |
| BF/S label | 10001111dddddddd | Delayed branch, if T = 0, disp × 2 + PC → PC; if T = 1, nop | 2/1* | — |
| BT label | 10001001dddddddd | If T = 1, disp × 2 + PC → PC; if T = 0, nop | 3/1* | — |
| BT/S label | 10001101dddddddd | Delayed branch, if T = 1, disp × 2 + PC → PC; if T = 0, nop | 2/1* | — |
| BRA label | 1010dddddddddddd | Delayed branch, disp × 2 + PC → PC | 2 | — |
| BRAF Rm | 0000mmmm00100011 | Delayed branch, Rm + PC → PC | 2 | — |
| BSR label | 1011dddddddddddd | Delayed branch, PC → PR, disp × 2 + PC → PC | 2 | — |
| BSRF Rm | 0000mmmm00000011 | Delayed branch, PC → PR, Rm + PC → PC | 2 | — |
| JMP @Rm | 0100mmmm00101011 | Delayed branch, Rm → PC | 2 | — |
| JSR @Rm | 0100mmmm00001011 | Delayed branch, PC → PR, Rm → PC | 2 | — |
| RTS | 0000000000001011 | Delayed branch, PR → PC | 2 | — |

Note: * One state when the program does not branch.

- System Control Instructions

| Instruction | Instruction Code | Operation | Execution States | T Bit |
|------------------|------------------|---------------------------------------|------------------|-------|
| CLRT | 0000000000001000 | 0 → T | 1 | 0 |
| CLRMAC | 0000000000101000 | 0 → MACH, MACL | 1 | — |
| LDC Rm, SR | 0100mmmm00001110 | Rm → SR | 1 | LSB |
| LDC Rm, GBR | 0100mmmm00011110 | Rm → GBR | 1 | — |
| LDC Rm, VBR | 0100mmmm00101110 | Rm → VBR | 1 | — |
| LDC.L @Rm+, SR | 0100mmmm00000111 | (Rm) → SR, Rm + 4 → Rm | 3 | LSB |
| LDC.L @Rm+, GBR | 0100mmmm00010111 | (Rm) → GBR, Rm + 4 → Rm | 3 | — |
| LDC.L @Rm+, VBR | 0100mmmm00100111 | (Rm) → VBR, Rm + 4 → Rm | 3 | — |
| LDS Rm, MACH | 0100mmmm00001010 | Rm → MACH | 1 | — |
| LDS Rm, MACL | 0100mmmm00011010 | Rm → MACL | 1 | — |
| LDS Rm, PR | 0100mmmm00101010 | Rm → PR | 1 | — |
| LDS.L @Rm+, MACH | 0100mmmm00000110 | (Rm) → MACH, Rm + 4 → Rm | 1 | — |
| LDS.L @Rm+, MACL | 0100mmmm00010110 | (Rm) → MACL, Rm + 4 → Rm | 1 | — |
| LDS.L @Rm+, PR | 0100mmmm00100110 | (Rm) → PR, Rm + 4 → Rm | 1 | — |
| NOP | 0000000000001001 | No operation | 1 | — |
| RTE | 0000000000101011 | Delayed branch, stack area → PC/SR | 4 | — |
| SETT | 000000000011000 | 1 → T | 1 | 1 |
| SLEEP | 000000000011011 | Sleep | 3* | — |
| STC SR, Rn | 0000nnnn00000010 | SR → Rn | 1 | — |
| STC GBR, Rn | 0000nnnn00010010 | GBR → Rn | 1 | — |
| STC VBR, Rn | 0000nnnn00100010 | VBR → Rn | 1 | — |
| STC.L SR, @-Rn | 0100nnnn00000011 | Rn - 4 → Rn, SR → (Rn) | 2 | — |
| STC.L GBR, @-Rn | 0100nnnn00010011 | Rn - 4 → Rn, GBR → (Rn) | 2 | — |
| STC.L VBR, @-Rn | 0100nnnn00100011 | Rn - 4 → Rn, BR → (Rn) | 2 | — |
| STS MACH, Rn | 0000nnnn00001010 | MACH → Rn | 1 | — |
| STS MACL, Rn | 0000nnnn00011010 | MACL → Rn | 1 | — |
| STS PR, Rn | 0000nnnn00101010 | PR → Rn | 1 | — |
| STS.L MACH, @-Rn | 0100nnnn00000010 | Rn - 4 → Rn, MACH → (Rn) | 1 | — |
| STS.L MACL, @-Rn | 0100nnnn00010010 | Rn - 4 → Rn, MACL → (Rn) | 1 | — |
| STS.L PR, @-Rn | 0100nnnn00100010 | Rn - 4 → Rn, PR → (Rn) | 1 | — |

| Instruction | Instruction Code | Operation | Execution States | T Bit |
|-------------|------------------|---|------------------|-------|
| TRAPA #imm | 11000011iiiiiii | PC/SR → stack area, (imm × 4 + 8 VBR) → PC | 8 | — |

Note: * The number of execution states before the chip enters sleep mode: The execution states shown in the table are minimums. The actual number of states may be increased when (1) contention occurs between instruction fetches and data access, or (2) when the destination register of the load instruction (memory → register) equals to the register used by the next instruction.

2.6 Processing States

2.6.1 State Transitions

The CPU has five processing states: reset, exception processing, bus release, program execution and power-down. Figure 2.4 shows the transitions between the states.

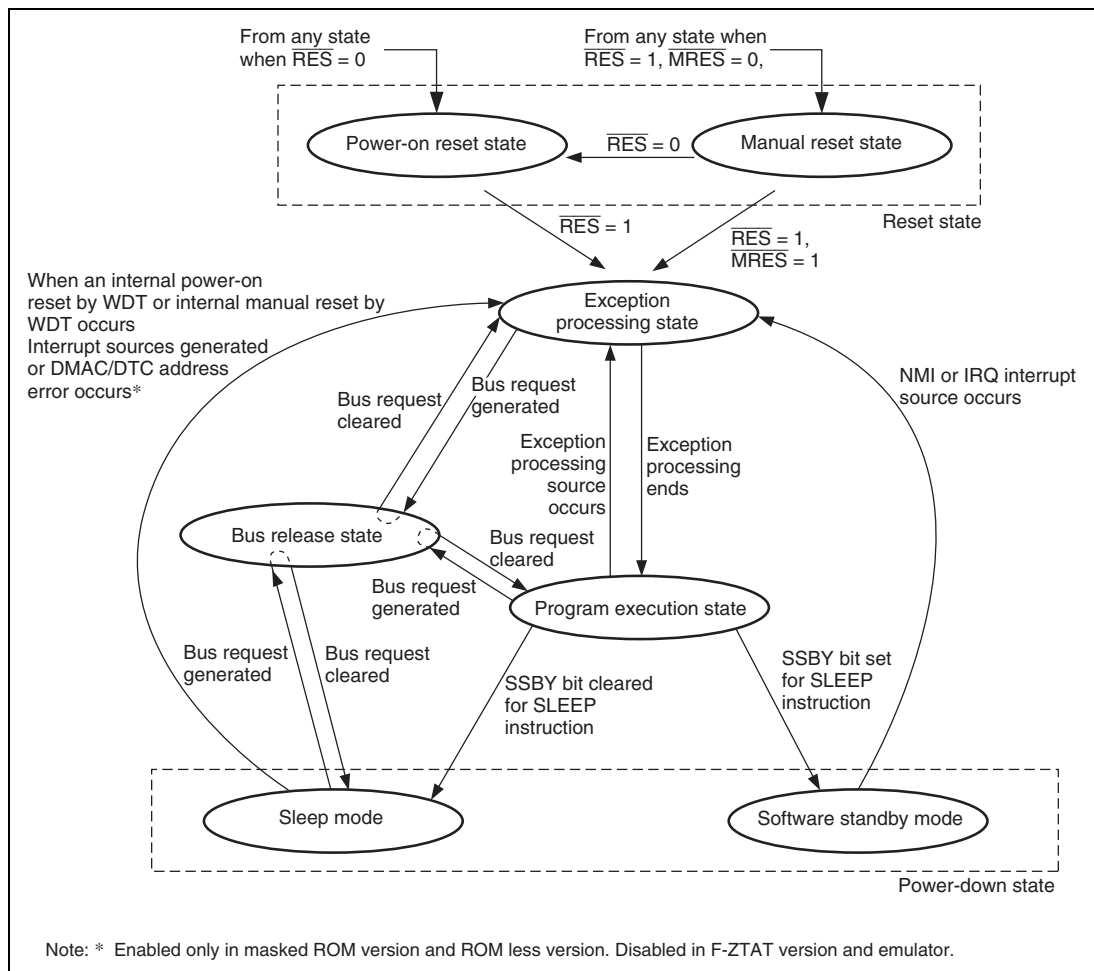

Figure 2.4 Transitions between Processing States

Reset State: The CPU resets in the reset state. When the $\overline{\text{RES}}$ pin level goes low, the power-on reset state is entered. When the $\overline{\text{RES}}$ pin is high and the $\overline{\text{MRES}}$ pin is low, the manual reset state is entered.

Exception Processing State: The exception processing state is a transient state that occurs when exception processing sources such as resets or interrupts alter the CPU's processing state flow.

For a reset, the initial values of the program counter (PC) (execution start address) and stack pointer (SP) are fetched from the exception processing vector table and stored; the CPU then branches to the execution start address and execution of the program begins.

For an interrupt, the stack pointer (SP) is accessed and the program counter (PC) and status register (SR) are saved to the stack area. The exception service routine start address is fetched from the exception processing vector table; the CPU then branches to that address and the program starts executing, thereby entering the program execution state.

Program Execution State: In the program execution state, the CPU sequentially executes the program.

Power-Down State: In the power-down state, the CPU operation halts and power consumption declines. The SLEEP instruction places the CPU in the sleep mode or the software standby mode.

Bus Release State: In the bus release state, the CPU releases bus mastership to the device that has requested them.

Section 3 MCU Operating Modes

3.1 Selection of Operating Modes

This LSI has four operating modes and four clock modes. The operating mode is determined by the setting of MD3 to MD0, and FWP pins. Do not set these pins in the other way than the combination shown in table 3.1. When power is applied to the system, be sure to conduct power-on reset.

Table 3.1 Selection of Operating Modes

| Mode No. | Pin Setting | | | | | Mode Name | On-Chip ROM | Bus Width of CS0, CS4 Area | |
|----------------|-------------|-------------------|-------------------|-----|-----|-------------------------------------|-------------|----------------------------|---------|
| | FWP | MD3* ¹ | MD2* ¹ | MD1 | MD0 | | | SH7144 | SH7145 |
| Mode 0 | 1 | x | x | 0 | 0 | MCU extension mode 0 | Not active | 8 bits | 16 bits |
| Mode 1 | 1 | x | x | 0 | 1 | MCU extension mode 1 | Not active | 16 bits | 32 bits |
| Mode 2 | 1 | x | x | 1 | 0 | MCU extension mode 2 | Active | Set by BCR1 of BSC | |
| Mode 3 | 1 | x | x | 1 | 1 | Single chip mode | Active | — | |
| * ² | 0 | x | x | 0 | 0 | Boot mode* ² | Active | Set by BCR1 of BSC | |
| * ² | 0 | x | x | 0 | 1 | | | — | |
| * ² | 0 | x | x | 1 | 0 | User programming mode* ² | Active | Set by BCR1 of BSC | |
| * ² | 0 | x | x | 1 | 1 | | | — | |

[Legend]

x: Don't care

Notes: 1. MD3 and MD2 pins are used to select clock mode.

2. User programming mode for flash memory. Supported in only F-ZTAT version.

There are two modes as the MCU operating modes: MCU extension mode and single chip mode. There are two modes to program the flash memory (on-board programming mode): boot mode and user programming mode.

The clock mode is selected by the input of MD2 and MD3 pins.

Table 3.2 Clock Mode Setting

| Clock Mode No. | Pin Setting | | Clock Ratio (when input clock is 1) | | |
|----------------|-------------|-----|-------------------------------------|------------------------------|--------------------------|
| | MD3 | MD2 | System clock (ϕ) | Peripheral clock ($P\phi$) | System clock output (CK) |
| 0 | 0 | 0 | $\times 1$ | $\times 1$ | $\times 1$ |
| 1 | 0 | 1 | $\times 2$ | $\times 2$ | $\times 2$ |
| 2 | 1 | 0 | $\times 4$ | $\times 4^*$ | $\times 4$ |
| 3 | 1 | 1 | $\times 4$ | $\times 2$ | $\times 4$ |

Note: * The maximum clock input frequency is 10MHz because the $p\phi$ is specified as 40MHz or less.

3.2 Input/Output Pins

Table 3.3 describes the configuration of operating mode related pin.

Table 3.3 Pin Configuration

| Pin Name | Input/Output | Function |
|-----------------|---------------------|--|
| MD0 | Input | Designates operating mode through the level applied to this pin |
| MD1 | Input | Designates operating mode through the level applied to this pin |
| MD2 | Input | Designates clock mode through the level applied to this pin |
| MD3 | Input | Designates clock mode through the level applied to this pin |
| FWP | Input | Pin for the hardware protection against programming/erasing the on-chip flash memory |

3.3 Operating Modes

3.3.1 Mode 0 (MCU Extension Mode 0)

CS0 space and CS4 space become external memory spaces with 8-bit bus width in SH7144 or 16-bit bus width in SH7145.

3.3.2 Mode 1 (MCU Extension Mode 1)

CS0 space and CS4 space become external memory spaces with 16-bit bus width in SH7144 or 32-bit bus width in SH7145.

3.3.3 Mode 2 (MCU Extension Mode 2)

The on-chip ROM is active and CS0 space can be used in this mode.

3.3.4 Mode 3 (Single Chip Mode)

All ports can be used in this mode, however the external address cannot be used.

3.3.5 Clock Mode

The input waveform frequency can be used as is, doubled or quadrupled as system clock frequency in mode 0 to mode 3.

3.4 Address Map

The address map for the operating modes are shown in figure 3.1.

| Modes 0 and 1 On-chip ROM disabled mode | | Mode 2 On-chip ROM enabled mode | | Mode 3 Single-chip mode | | |
|--|-------------------------------------|------------------------------------|-------------------------------------|----------------------------|--------------------------|-------------------------------------|
| H'00000000 | CS0 space | H'00000000 | On-chip ROM (256 kbytes) | H'00000000 | On-chip ROM (256 kbytes) | |
| H'003FFFFFFF | | H'0003FFFF | Reserved area | H'0003FFFF | | |
| H'00400000 | CS1 space | H'00040000 | CS0 space | H'00040000 | Reserved area | |
| H'007FFFFFFF | | H'0007FFFF | | CS1 space | | |
| H'00800000 | CS2 space | H'00800000 | CS2 space | | | |
| H'00BFFFFFFF | | H'00BFFFFF | | | | |
| H'00C00000 | CS3 space | H'00C00000 | CS3 space | | | |
| H'00FFFFFFF | | H'00FFFFFF | | | | |
| H'01000000 | CS4 space* | H'01000000 | Reserved area | | | |
| H'013FFFFFFF | | H'011FFFFF | CS4 space* | | | |
| H'01400000 | H'013FFFFF | CS5 space* | | | | |
| H'017FFFFFFF | CS5 space* | | H'017FFFFF | CS6 space* | | |
| H'01800000 | | H'01800000 | | | | |
| H'01BFFFFFFF | CS6 space* | H'01BFFFFF | CS7 space* | | | |
| H'01C00000 | | H'01C00000 | | | | |
| H'01FFFFFFF | Reserved area | H'01FFFFFF | Reserved area | Reserved area | | |
| H'02000000 | | H'02000000 | | | | |
| H'FFFF7FFF | On-chip peripheral I/O registers | H'FFFF7FFF | On-chip peripheral I/O registers | H'FFFF7FFF | | On-chip peripheral I/O registers |
| H'FFFF8000 | | H'FFFF8000 | | | | |
| H'FFFFBFFF | Reserved area | H'FFFFBFFF | Reserved area | H'FFFFBFFF | | Reserved area |
| H'FFFC000 | | H'FFFC000 | | | | |
| H'FFFDFFF | On-chip RAM (8 kbytes) | H'FFFDFFF | On-chip RAM (8 kbytes) | H'FFFDFFF | | On-chip RAM (8 kbytes) |
| H'FFFE000 | | H'FFFE000 | | | | |
| H'FFFFFFF | | H'FFFFFFF | | H'FFFFFFF | | |

Note: * CS4 space to CS7 space are available only in the masked ROM version and ROM less version. These spaces are reserved in the flash memory version and emulator.

Figure 3.1 Address Map for Each Operating Mode

3.5 Initial State in This LSI

In the initial state of this LSI, some of on-chip modules are set in module standby state for saving power. When operating these modules, clear module standby state according to the procedure in section 24, Power-Down Modes.

3.6 Note on Changing Operating Mode

When changing operating mode while power is applied to this LSI, make sure to do it in the power-on reset state (that is, the low level is applied to the $\overline{\text{RES}}$ pin). In addition, when changing clock mode, secure the reset oscillation stabilization time (t_{osc1}) after clock mode change.

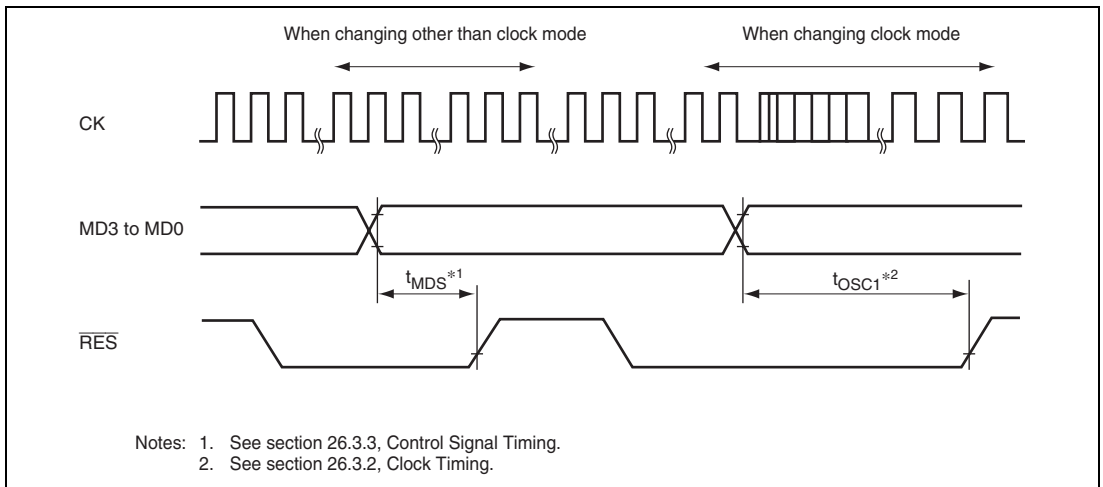

Figure 3.2 Reset Input Timing when Changing Operating Mode

Section 4 Clock Pulse Generator

This LSI has an on-chip clock pulse generator (CPG) that generates the system clock (ϕ) and the peripheral clock ($P\phi$), and then makes internal clock ($\phi/2$ to $\phi/8192$ and $P\phi/2$ to $P\phi/1024$) out of this generated clock. The CPG consists of an oscillator, PLL circuit, and pre-scaler. A block diagram of the clock pulse generator is shown in figure 4.1. The frequency from the oscillator can be modified by the PLL circuit.

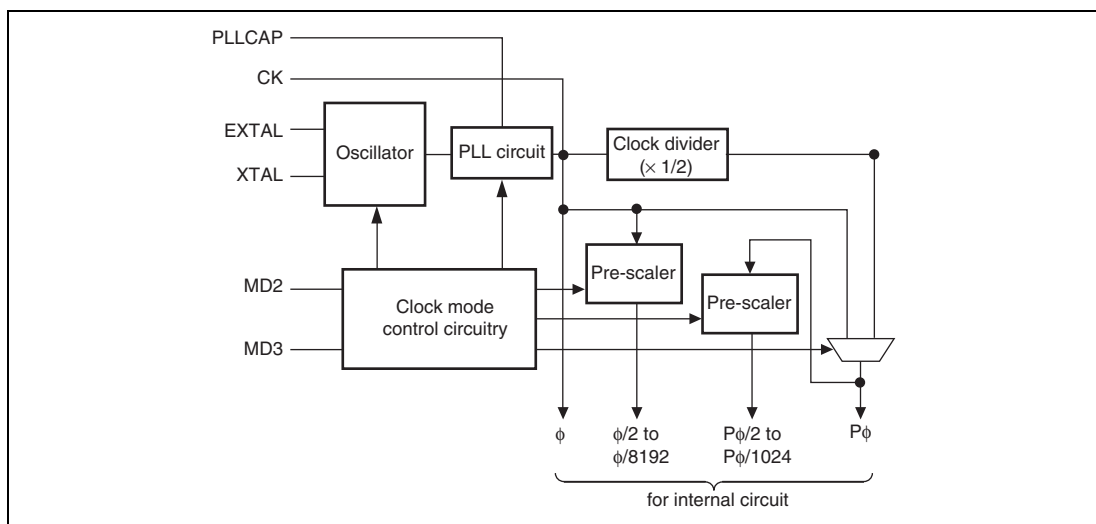

Figure 4.1 Block Diagram of Clock Pulse Generator

Table 4.1 shows the operating clock for each module.

Table 4.1 Operating Clock for Each Module

| Operating clock | Operating Module |
|-------------------------|------------------------------|
| System clock (ϕ) | CPU |
| | UBC |
| | DTC |
| | BSC |
| | DMAC |
| | WDT |
| | AUD |
| | ROM |
| | RAM |
| | Peripheral clock ($P\phi$) |
| POE | |
| SCI | |
| I ² C | |
| A/D | |
| CMT | |
| H-UDI | |

4.1 Oscillator

Clock pulses can be supplied from a connected crystal resonator or an external clock.

4.1.1 Connecting Crystal Resonator

A crystal resonator can be connected as shown in figure 4.2. Use the damping resistance (R_d) listed in table 4.2. Use a crystal resonator that has a resonance frequency of 4 to 12.5 MHz. It is recommended to consult the crystal resonator manufacturer concerning the compatibility of the crystal resonator and the LSI.

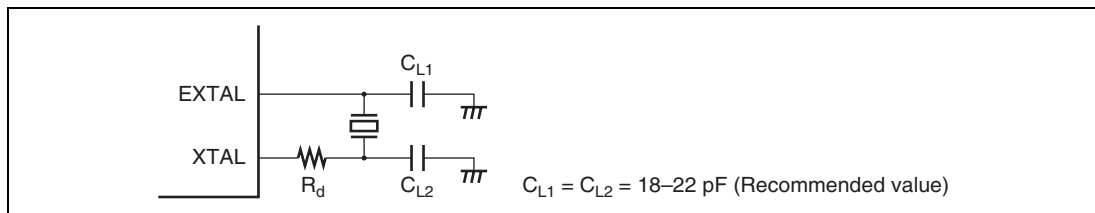

Figure 4.2 Connection of Crystal Resonator (Example)

Table 4.2 Damping Resistance Values (Recommended Values)

| Frequency (MHz) | 4 | 8 | 10 | 12.5 |
|--------------------|-----|-----|----|------|
| R_d (Ω) | 500 | 200 | 0 | 0 |

Figure 4.3 shows an equivalent circuit of the crystal resonator. Use a crystal resonator with the characteristics listed in table 4.3.

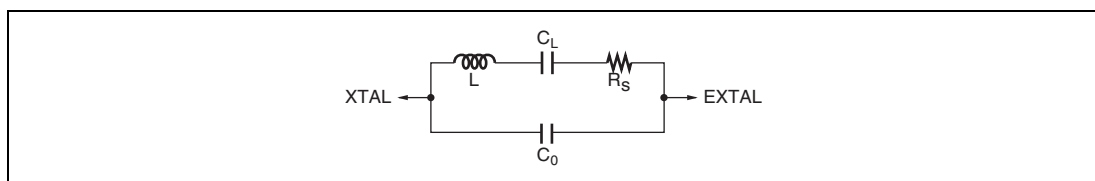

Figure 4.3 Crystal Resonator Equivalent Circuit

Table 4.3 Crystal Resonator Characteristics

| | | | | |
|---------------------|-----|----|----|------|
| Frequency (MHz) | 4 | 8 | 10 | 12.5 |
| Rs max (Ω) | 120 | 80 | 60 | 50 |
| Co max (pF) | 7 | 7 | 7 | 7 |

4.1.2 External Clock Input Method

Figure 4.4 shows an example of an external clock input connection. In this case, make the external clock high level to stop it when in software standby mode. During operation, make the external input clock frequency 4 to 12.5 MHz.

When leaving the XTAL pin open, make sure the parasitic capacitance is less than 10 pF.

Even when inputting an external clock, be sure to wait at least the oscillation stabilization time in power-on sequence or in releasing software standby mode, in order to ensure the PLL stabilization time.

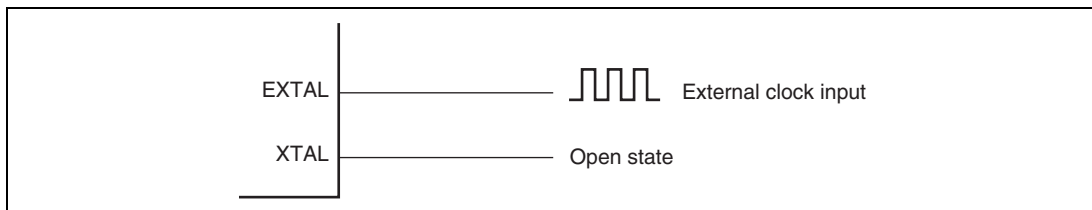
**Figure 4.4 Example of External Clock Connection**

4.2 Function for Detecting Oscillator Halt

This CPG can detect a clock halt and automatically cause the timer pins to become high-impedance when any system abnormality causes the oscillator to halt. That is, when a change of EXTAL has not been detected, the high-current 6 pins (PE9/TIOC3B/SCK3/ $\overline{\text{TRST}}$ *, PE11/TIOC3D/RXD3/TDO*, PE12/TIOC4A/TXD3/TCK*, PE13/TIOC4B/ $\overline{\text{MRES}}$, PE14/TIOC4C/DACK0, PE15/TIOC4D/DACK1/ $\overline{\text{IRQOUT}}$) can be set to high-impedance regardless of PFC setting. Refer to section 17.1.11, High-Current Port Control Register (PPCR), for more details.

Even in software standby mode, these 6 pins can be set to high-impedance regardless of PFC setting. Refer to section 17.1.11, High-Current Port Control Register (PPCR), for more details. These pins enter the normal state after software standby mode is released. When abnormalities that halt the oscillator occur except in software standby mode, other LSI operations become undefined. In this case, LSI operations, including these 6 pins, become undefined even when the oscillator operation starts again.

In the case of using E10A, the high-impedance function is disabled when an oscillation stop is detected, or when in software standby state for the three pins of PE9/TIOC3B/SCK3/ $\overline{\text{TRST}}$, PE11/TIOC3D/RXD3/TDO, and PE12/TIOC4A/TxD3/TCK of the SH7145.

Note: * Only in the SH7145.

4.3 Usage Notes

4.3.1 Note on Crystal Resonator

A sufficient evaluation at the user's site is necessary to use the LSI, by referring the resonator connection examples shown in this section, because various characteristics related to the crystal resonator are closely linked to the user's board design. As the oscillator circuit's circuit constant will depend on the resonator and the floating capacitance of the mounting circuit, the value of each external circuit's component should be determined in consultation with the resonator manufacturer. The design must ensure that a voltage exceeding the maximum rating is not applied to the oscillator pin.

4.3.2 Notes on Board Design

Measures against radiation noise are taken in this LSI. If further reduction in radiation noise is needed, it is recommended to use a multiple layer board and provide a layer exclusive to the system ground.

When using a crystal resonator, place the crystal resonator and its load capacitors as close as possible to the XTAL and EXTAL pins. Do not route any signal lines near the oscillator circuitry as shown in figure 4.5. Otherwise, correct oscillation can be interfered by induction.

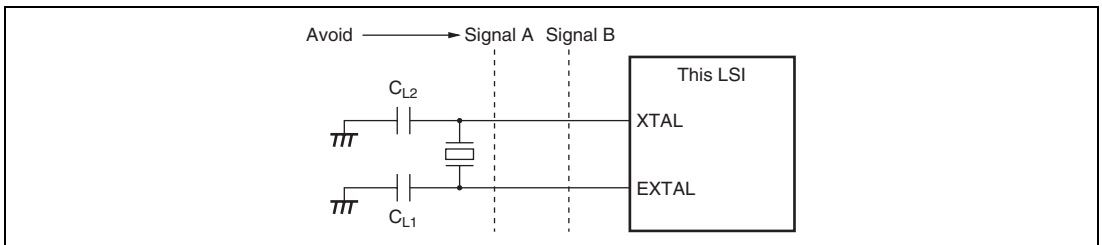

Figure 4.5 Cautions for Oscillator Circuit Board Design

A circuitry shown in figure 4.6 is recommended as an external circuitry around the PLL. Place oscillation stabilization capacitor C1 close to the PLLCAP pin, and ensure that no other signal lines cross this line. Separate the PLL power lines (PLL V_{CC} , PLL V_{SS}) and the system power lines (V_{CC} , V_{SS}) at the board power supply source, and be sure to insert bypass capacitors CB and CPB close to the pins.

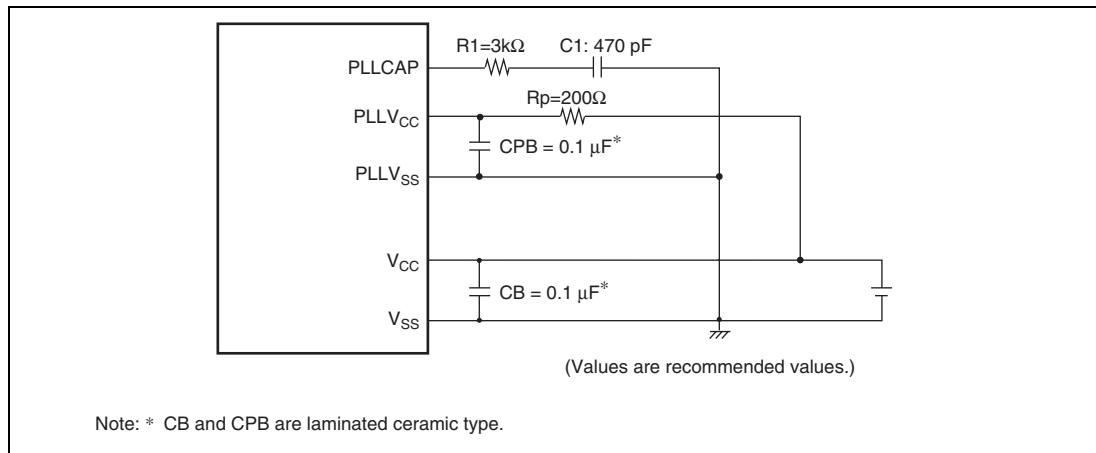

Figure 4.6 Recommended External Circuitry around PLL

In principle, electromagnetic waves are emitted from an LSI in operation. This LSI regards the lower of the system clock (ϕ) and the peripheral clock ($P\phi$) as fundamental (for example, if $\phi = 40$ MHz and $P\phi = 40$ MHz, then 40 MHz), and the peak of electromagnetic waves is in the high frequency band. When this LSI is used adjacent to apparatuses sensible to electromagnetic waves such as FM/VHF band receivers, it is recommended to use a board with at least four layers and provide a layer exclusive to the system ground.

Section 5 Exception Processing

5.1 Overview

5.1.1 Types of Exception Processing and Priority

Exception processing is started by four sources: resets, address errors, interrupts and instructions and have the priority, as shown in table 5.1. When several exception processing sources occur at once, they are processed according to the priority.

Table 5.1 Types of Exception Processing and Priority Order

| Exception | Source | Priority |
|---------------|--|----------|
| Reset | Power-on reset | |
| | Manual reset | |
| Address error | CPU address error or AUD address error* ¹ | |
| | DMAC/DTC address error | |
| Interrupt | NMI | |
| | User break | |
| | H-UDI | |
| | IRQ | |
| | On-chip peripheral modules: | |
| Instructions | Trap instruction (TRAPA instruction) | |
| | General illegal instructions (undefined code) | |
| | Illegal slot instructions (undefined code placed directly after a delayed branch instruction* ² or instructions that rewrite the PC* ³) | |

Notes: 1. Only in the F-ZTAT version.

2. Delayed branch instructions: JMP, JSR, BRA, BSR, RTS, RTE, BF/S, BT/S, BSRF, and BRAF.

5. Exception Processing

3. Instructions that rewrite the PC: JMP, JSR, BRA, BSR, RTS, RTE, BT, BF, TRAPA, BF/S, BT/S, BSRF, and BRAF.

5.1.2 Exception Processing Operations

The exception processing sources are detected and begin processing according to the timing shown in table 5.2.

Table 5.2 Timing for Exception Source Detection and Start of Exception Processing

| Exception | Source | Timing of Source Detection and Start of Processing |
|---------------|------------------------------|--|
| Reset | Power-on reset | Starts when the $\overline{\text{RES}}$ pin changes from low to high or when WDT overflows. |
| | Manual reset | Starts when the $\overline{\text{MRES}}$ pin changes from low to high. |
| Address error | | Detected when instruction is decoded and starts when the execution of the previous instruction is completed. |
| Interrupts | | |
| Instructions | Trap instruction | Starts from the execution of a TRAPA instruction. |
| | General illegal instructions | Starts from the decoding of undefined code anytime except after a delayed branch instruction (delay slot). |
| | Illegal slot instructions | Starts from the decoding of undefined code placed in a delayed branch instruction (delay slot) or of instructions that rewrite the PC. |

When exception processing starts, the CPU operates as follows:

1. Exception processing triggered by reset:

The initial values of the program counter (PC) and stack pointer (SP) are fetched from the exception processing vector table (PC and SP are respectively the H'00000000 and H'00000004 addresses for power-on resets and the H'00000008 and H'0000000C addresses for manual resets). See section 5.1.3, Exception Processing Vector Table, for more information. H'00000000 is then written to the vector base register (VBR), and H'F (B'1111) is written to the interrupt mask bits (I3 to I0) of the status register (SR). The program begins running from the PC address fetched from the exception processing vector table.

2. Exception processing triggered by address errors, interrupts and instructions:

SR and PC are saved to the stack indicated by R15. For interrupt exception processing, the interrupt priority level is written to the SR's interrupt mask bits (I3 to I0). For address error and instruction exception processing, the I3 to I0 bits are not affected. The start address is then fetched from the exception processing vector table and the program begins running from that address.

5.1.3 Exception Processing Vector Table

Before exception processing begins running, the exception processing vector table must be set in memory. The exception processing vector table stores the start addresses of exception service routines. (The reset exception processing table holds the initial values of PC and SP.)

All exception sources are given different vector numbers and vector table address offsets. The vector table addresses are calculated from these vector numbers and vector table address offsets. During exception processing, the start addresses of the exception service routines are fetched from the exception processing vector table that is indicated by this vector table address.

Table 5.3 shows the vector numbers and vector table address offsets. Table 5.4 shows how vector table addresses are calculated.

Table 5.3 Exception Processing Vector Table

| Exception Sources | | Vector Numbers | Vector Table Address Offset |
|--|------------|----------------|-----------------------------|
| Power-on reset | PC | 0 | H'00000000 to H'00000003 |
| | SP | 1 | H'00000004 to H'00000007 |
| Manual reset | PC | 2 | H'00000008 to H'0000000B |
| | SP | 3 | H'0000000C to H'0000000F |
| General illegal instruction | | 4 | H'00000010 to H'00000013 |
| (Reserved by system) | | 5 | H'00000014 to H'00000017 |
| Slot illegal instruction | | 6 | H'00000018 to H'0000001B |
| (Reserved by system) | | 7 | H'0000001C to H'0000001F |
| | | 8 | H'00000020 to H'00000023 |
| CPU address error or AUD address error* ¹ | | 9 | H'00000024 to H'00000027 |
| DMAC/DTC address error | | 10 | H'00000028 to H'0000002B |
| Interrupts | NMI | 11 | H'0000002C to H'0000002F |
| | User break | 12 | H'00000030 to H'00000033 |
| (Reserved by system) | | 13 | H'00000034 to H'00000037 |
| H-UDI | | 14 | H'00000038 to H'0000003B |
| (Reserved by system) | | 15 | H'0000003C to H'0000003F |
| | | : | : |
| | | 31 | H'0000007C to H'0000007F |

| Exception Sources | | Vector Numbers | Vector Table Address Offset |
|---|------|----------------|-----------------------------|
| Trap instruction (user vector) | | 32 | H'00000080 to H'00000083 |
| | | : | : |
| | | 63 | H'000000FC to H'000000FF |
| Interrupts | IRQ0 | 64 | H'00000100 to H'00000103 |
| | IRQ1 | 65 | H'00000104 to H'00000107 |
| | IRQ2 | 66 | H'00000108 to H'0000010B |
| | IRQ3 | 67 | H'0000010C to H'0000010F |
| | IRQ4 | 68 | H'00000110 to H'00000113 |
| | IRQ5 | 69 | H'00000114 to H'00000117 |
| | IRQ6 | 70 | H'00000118 to H'0000011B |
| | IRQ7 | 71 | H'0000011C to H'0000011F |
| On-chip peripheral module* ² | | 72 | H'00000120 to H'00000123 |
| | | : | : |
| | | 255 | H'000003FC to H'000003FF |

Notes: 1. Only in the F-ZTAT version.

2. The vector numbers and vector table address offsets for each on-chip peripheral module interrupt are given in table 6.2.

Table 5.4 Calculating Exception Processing Vector Table Addresses

| Exception Source | Vector Table Address Calculation |
|--|---|
| Resets | Vector table address = (vector table address offset) = (vector number) × 4 |
| Address errors, interrupts, instructions | Vector table address = VBR + (vector table address offset) = VBR + (vector number) × 4 |

Notes: 1. VBR: Vector base register

2. Vector table address offset: See table 5.3.

3. Vector number: See table 5.3.

5.2 Resets

5.2.1 Types of Reset

Resets have the highest priority of any exception source. There are two types of resets: manual resets and power-on resets. As table 5.5 shows, both types of resets initialize the internal status of the CPU. In power-on resets, all registers of the on-chip peripheral modules are initialized; in manual resets, they are not.

Table 5.5 Reset Status

| Type | Conditions for Transition to Reset Status | | | Internal Status | | |
|----------------|---|--------------|--------------------------|-----------------|---------------------------|-------------------|
| | $\overline{\text{RES}}$ | WDT Overflow | $\overline{\text{MRES}}$ | CPU/INTC | On-Chip Peripheral Module | POE, PFC, IO Port |
| Power-on reset | Low | — | — | Initialized | Initialized | Initialized |
| | High | Overflow | High | Initialized | Initialized | Not initialized |
| Manual reset | High | — | Low | Initialized | Not initialized | Not initialized |

5.2.2 Power-On Reset

Power-On Reset by $\overline{\text{RES}}$ Pin: When the $\overline{\text{RES}}$ pin is driven low, the LSI becomes to be a power-on reset state. To reliably reset the LSI, the $\overline{\text{RES}}$ pin should be kept at low for at least the duration of the oscillation settling time when applying power or when in software standby mode (when the clock circuit is halted) or at least $25 t_{\text{cyc}}$ when the clock circuit is running. During power-on reset, CPU internal status and all registers of on-chip peripheral modules are initialized. See appendix A, Pin States, for the status of individual pins during the power-on reset status.

In the power-on reset status, power-on reset exception processing starts when the $\overline{\text{RES}}$ pin is first driven low for a set period of time and then returned to high. The CPU will then operate as follows:

1. The initial value (execution start address) of the program counter (PC) is fetched from the exception processing vector table.
2. The initial value of the stack pointer (SP) is fetched from the exception processing vector table.
3. The vector base register (VBR) is cleared to H'00000000 and the interrupt mask bits (I3 to I0) of the status register (SR) are set to H'F (B'1111).

4. The values fetched from the exception processing vector table are set in PC and SP, then the program begins executing.

Be certain to always perform power-on reset processing when turning the system power on.

Power-On Reset by WDT: When a setting is made for a power-on reset to be generated in the WDT's watchdog timer mode, and the WDT's TCNT overflows, the LSI becomes to be a power-on reset state.

The POE (Port Output Enable) function registers in the MTU, the pin function controller (PFC) registers, and I/O port registers are not initialized by the reset signal generated by the WDT (these registers are only initialized by a power-on reset from outside of the chip).

If reset caused by the input signal at the $\overline{\text{RES}}$ pin and a reset caused by WDT overflow occur simultaneously, the $\overline{\text{RES}}$ pin reset has priority, and the WOVF bit in RSTCSR is cleared to 0. When WDT-initiated power-on reset processing is started, the CPU operates as follows:

1. The initial value (execution start address) of the program counter (PC) is fetched from the exception processing vector table.
2. The initial value of the stack pointer (SP) is fetched from the exception processing vector table.
3. The vector base register (VBR) is cleared to H'00000000 and the interrupt mask bits (I3-I0) of the status register (SR) are set to H'F (B'1111).
4. The values fetched from the exception processing vector table are set in the PC and SP, then the program begins executing.

5.2.3 Manual Reset

When the $\overline{\text{RES}}$ pin is high and the $\overline{\text{MRES}}$ pin is driven low, the LSI becomes to be a manual reset state. To reliably reset the LSI, the $\overline{\text{MRES}}$ pin should be kept at low for at least the duration of the oscillation settling time that is set in WDT when in software standby mode (when the clock is halted) or at least $25 t_{\text{cyc}}$ when the clock is operating. During manual reset, the CPU internal status is initialized. Registers of on-chip peripheral modules are not initialized. When the LSI enters manual reset status in the middle of a bus cycle, manual reset exception processing does not start until the bus cycle has ended. Thus, manual resets do not abort bus cycles. However, once $\overline{\text{MRES}}$ is driven low, hold the low level until the CPU becomes to be a manual reset mode after the bus cycle ends. (Keep at low level for at least the longest bus cycle). See appendix A, Pin States, for the status of individual pins during manual reset mode.

In the manual reset status, manual reset exception processing starts when the $\overline{\text{MRES}}$ pin is first kept low for a set period of time and then returned to high. The CPU will then operate in the same procedures as described for power-on resets.

5.3 Address Errors

5.3.1 Cause of Address Error Exception

Address errors occur when instructions are fetched or data read or written, as shown in table 5.6.

Table 5.6 Bus Cycles and Address Errors

| Bus Cycle | | | |
|----------------------|---------------------------|---|-----------------------|
| Type | Bus Master | Bus Cycle Description | Address Errors |
| Instruction fetch | CPU | Instruction fetched from even address | None (normal) |
| | | Instruction fetched from odd address | Address error occurs |
| | | Instruction fetched from other than on-chip peripheral module space* | None (normal) |
| | | Instruction fetched from on-chip peripheral module space* | Address error occurs |
| | | Instruction fetched from external memory space when in single chip mode | Address error occurs |
| Data read/write | CPU, DMAC, AUD, or DTC | Word data accessed from even address | None (normal) |
| | | Word data accessed from odd address | Address error occurs |
| | | Longword data accessed from a longword boundary | None (normal) |
| | | Longword data accessed from other than a long-word boundary | Address error occurs |
| | | Byte or word data accessed in on-chip peripheral module space* | None (normal) |
| | | Longword data accessed in 16-bit on-chip peripheral module space* | None (normal) |
| | | Longword data accessed in 8-bit on-chip peripheral module space* | Address error occurs |
| | | External memory space accessed when in single chip mode | Address error occurs |

Note: * See section 9, Bus State Controller (BSC), for more information on the on-chip peripheral module space.

5.3.2 Address Error Exception Processing

When an address error occurs, the bus cycle in which the address error occurred ends, the current instruction finishes, and then address error exception processing starts. The CPU operates as follows:

1. The status register (SR) is saved to the stack.
2. The program counter (PC) is saved to the stack. The PC value saved is the start address of the instruction to be executed after the last executed instruction.
3. The start address of the exception service routine is fetched from the exception processing vector table that corresponds to the occurred address error, and the program starts executing from that address. The jump in this case is not a delayed branch.

5.4 Interrupts

5.4.1 Interrupt Sources

Table 5.7 shows the sources that start the interrupt exception processing. They are NMI, user breaks, H-UDI, IRQ, and on-chip peripheral modules.

Table 5.7 Interrupt Sources

| Type | Request Source | Number of Sources |
|---------------------------|--|-------------------|
| NMI | NMI pin (external input) | 1 |
| User break | User break controller (UBC) | 1 |
| H-UDI | User debugging interface (H-UDI) | 1 |
| IRQ | $\overline{\text{IRQ0}}$ to $\overline{\text{IRQ7}}$ pins (external input) | 8 |
| On-chip peripheral module | Direct Memory Access Controller (DMAC) | 4 |
| | Multifunction timer unit (MTU) | 23 |
| | Data transfer controller (DTC) | 1 |
| | Compare match timer (CMT) | 2 |
| | A/D converter (A/D0 and A/D1) | 2 |
| | Serial communication interface (SCI0–SCI3) | 16 |
| | Watchdog timer (WDT) | 1 |
| | Input/output Port | 1 |
| | IIC bus interface (IIC) | 1 |

Each interrupt source is allocated a different vector number and vector table offset. See table 6.2 for more information on vector numbers and vector table address offsets.

5.4.2 Interrupt Priority Level

The interrupt priority order is predetermined. When multiple interrupts occur simultaneously (overlapped interruptions), the interrupt controller (INTC) determines their relative priorities and starts the exception processing according to the results.

The priority order of interrupts is expressed as priority levels 0 to 16, with priority 0 the lowest and priority 16 the highest. The NMI interrupt has priority 16 and cannot be masked, so it is always accepted. The priority level of user break interrupt and H-UDI is 15. IRQ interrupts and on-chip peripheral module interrupt priority levels can be set freely using the INTC's interrupt priority registers A to J (IPRA to IPRJ) as shown in table 5.8. The priority levels that can be set are 0 to 15. Level 16 cannot be set. See section 6.3.4, Interrupt Priority Registers A to J (IPRA to IPRJ), for more information on IPRA to IPRJ.

Table 5.8 Interrupt Priority

| Type | Priority Level | Comment |
|---------------------------|----------------|--|
| NMI | 16 | Fixed priority level. Cannot be masked. |
| User break | 15 | Fixed priority level. |
| H-UDI | 15 | Fixed priority level. |
| IRQ | 0 to 15 | Set with interrupt priority registers A to J (IPRA to IPRJ). |
| On-chip peripheral module | | |

5.4.3 Interrupt Exception Processing

When an interrupt occurs, the interrupt controller (INTC) ascertains its priority level. NMI is always accepted, but other interrupts are only accepted if they have a priority level higher than the priority level set in the interrupt mask bits (I3 to I0) of the status register (SR).

When an interrupt is accepted, exception processing begins. In interrupt exception processing, the CPU saves SR and the program counter (PC) to the stack. The priority level value of the accepted interrupt is written to SR bits I3 to I0. For NMI, however, the priority level is 16, but the value set in I3 to I0 is H'F (level 15). Next, the start address of the exception service routine is fetched from the exception processing vector table for the accepted interrupt, that address is jumped to and execution begins. See section 6.6, Operation, for more information on the interrupt exception processing.

5.5 Exceptions Triggered by Instructions

5.5.1 Types of Exceptions Triggered by Instructions

Exception processing can be triggered by trap instruction, illegal slot instructions, and general illegal instructions, as shown in table 5.9.

Table 5.9 Types of Exceptions Triggered by Instructions

| Type | Source Instruction | Comment |
|------------------------------|---|--|
| Trap instruction | TRAPA | — |
| Illegal slot instructions | Undefined code placed immediately after a delayed branch instruction (delay slot) or instructions that rewrite the PC | Delayed branch instructions: JMP, JSR, BRA, BSR, RTS, RTE, BF/S, BT/S, BSRF, BRAF Instructions that rewrite the PC: JMP, JSR, BRA, BSR, RTS, RTE, BT, BF, TRAPA, BF/S, BT/S, BSRF, BRAF |
| General illegal instructions | Undefined code anywhere besides in a delay slot | — |

5.5.2 Trap Instructions

When a TRAPA instruction is executed, trap instruction exception processing starts. The CPU operates as follows:

1. The status register (SR) is saved to the stack.
2. The program counter (PC) is saved to the stack. The PC value saved is the start address of the instruction to be executed after the TRAPA instruction.
3. The start address of the exception service routine is fetched from the exception processing vector table that corresponds to the vector number specified in the TRAPA instruction. That address is jumped to and the program starts executing. The jump in this case is not a delayed branch.

5.5.3 Illegal Slot Instructions

An instruction placed immediately after a delayed branch instruction is called “instruction placed in a delay slot”. When the instruction placed in the delay slot is an undefined code, illegal slot exception processing starts after the undefined code is decoded. Illegal slot exception processing also starts when an instruction that rewrites the program counter (PC) is placed in a delay slot and the instruction is decoded. The CPU handles an illegal slot instruction as follows:

1. The status register (SR) is saved to the stack.
2. The program counter (PC) is saved to the stack. The PC value saved is the target address of the delayed branch instruction immediately before the undefined code or the instruction that rewrites the PC.
3. The start address of the exception service routine is fetched from the exception processing vector table that corresponds to the exception that occurred. That address is jumped to and the program starts executing. The jump in this case is not a delayed branch.

5.5.4 General Illegal Instructions

When undefined code placed anywhere other than immediately after a delayed branch instruction (i.e., in a delay slot) is decoded, general illegal instruction exception processing starts. The CPU handles the general illegal instructions in the same procedures as in the illegal slot instructions. Unlike processing of illegal slot instructions, however, the program counter value that is stacked is the start address of the undefined code.

5.6 Cases when Exception Sources Are not Accepted

When an address error or interrupt is generated directly after a delayed branch instruction or interrupt-disabled instruction, it is sometimes not accepted immediately but stored instead, as shown in table 5.10. In this case, it will be accepted when an instruction that can accept the exception is decoded.

Table 5.10 Generation of Exception Sources Immediately after Delayed Branch Instruction or Interrupt-Disabled Instruction

| Point of Occurrence | Exception Source | |
|---|------------------|--------------|
| | Address Error | Interrupt |
| Immediately after a delayed branch instruction* ¹ | Not accepted | Not accepted |
| Immediately after an interrupt-disabled instruction* ² | Accepted | Not accepted |

Notes: 1. Delayed branch instructions: JMP, JSR, BRA, BSR, RTS, RTE, BF/S, BT/S, BSRF, and BRAF

2. Interrupt-disabled instructions: LDC, LDC.L, STC, STC.L, LDS, LDS.L, STS, and STS.L

5.6.1 Immediately after Delayed Branch Instruction

When an instruction placed immediately after a delayed branch instruction (delay slot) is decoded, neither address errors nor interrupts are accepted. The delayed branch instruction and the instruction placed immediately after it (delay slot) are always executed consecutively, so no exception processing occurs during this period.

5.6.2 Immediately after Interrupt-Disabled Instruction

When an instruction placed immediately after an interrupt-disabled instruction is decoded, interrupts are not accepted. Address errors can be accepted.

5.7 Stack Status after Exception Processing Ends

The status of the stack after exception processing ends is shown in table 5.11.

Table 5.11 Stack Status after Exception Processing Ends

| Types | Stack Status |
|-----------------------------|--|
| Address error | <p>SP → Address of instruction after executed instruction 32 bits</p> <p>SR 32 bits</p> |
| Trap instruction | <p>SP → Address of instruction after TRAPA instruction 32 bits</p> <p>SR 32 bits</p> |
| General illegal instruction | <p>SP → Address of instruction after general illegal instruction 32 bits</p> <p>SR 32 bits</p> |
| Interrupt | <p>SP → Address of instruction after executed instruction 32 bits</p> <p>SR 32 bits</p> |
| Illegal slot instruction | <p>SP → Jump destination address of delay branch instruction 32 bits</p> <p>SR 32 bits</p> |

5.8 Usage Notes

5.8.1 Value of Stack Pointer (SP)

The value of the stack pointer must always be a multiple of four. If it is not, an address error will occur when the stack is accessed during exception processing.

5.8.2 Value of Vector Base Register (VBR)

The value of the vector base register must always be a multiple of four. If it is not, an address error will occur when the stack is accessed during exception processing.

5.8.3 Address Errors Caused by Stacking of Address Error Exception Processing

When the value of the stack pointer is not a multiple of four, an address error will occur during stacking of the exception processing (interrupts, etc.) and address error exception processing will start after the first exception processing is ended. Address errors will also occur in the stacking for this address error exception processing. To ensure that address error exception processing does not go into an endless loop, no address errors are accepted at that point. This allows program control to be shifted to the service routine for address error exception and enables error processing.

When an address error occurs during exception processing stacking, the stacking bus cycle (write) is executed. During stacking of the status register (SR) and program counter (PC), the value of SP is reduced by 4 for both of SR and PC, therefore the value of SP is still not a multiple of four after the stacking. The address value output during stacking is the SP value, so the address itself where the error occurred is output. This means that the write data stacked is undefined.

Section 6 Interrupt Controller (INTC)

The interrupt controller (INTC) ascertains the priority of interrupt sources and controls interrupt requests to the CPU.

6.1 Features

- 16 levels of interrupt priority
- NMI noise canceler function
- Occurrence of interrupt can be reported externally (IRQOUT pin)

Figure 6.1 shows a block diagram of the INTC.

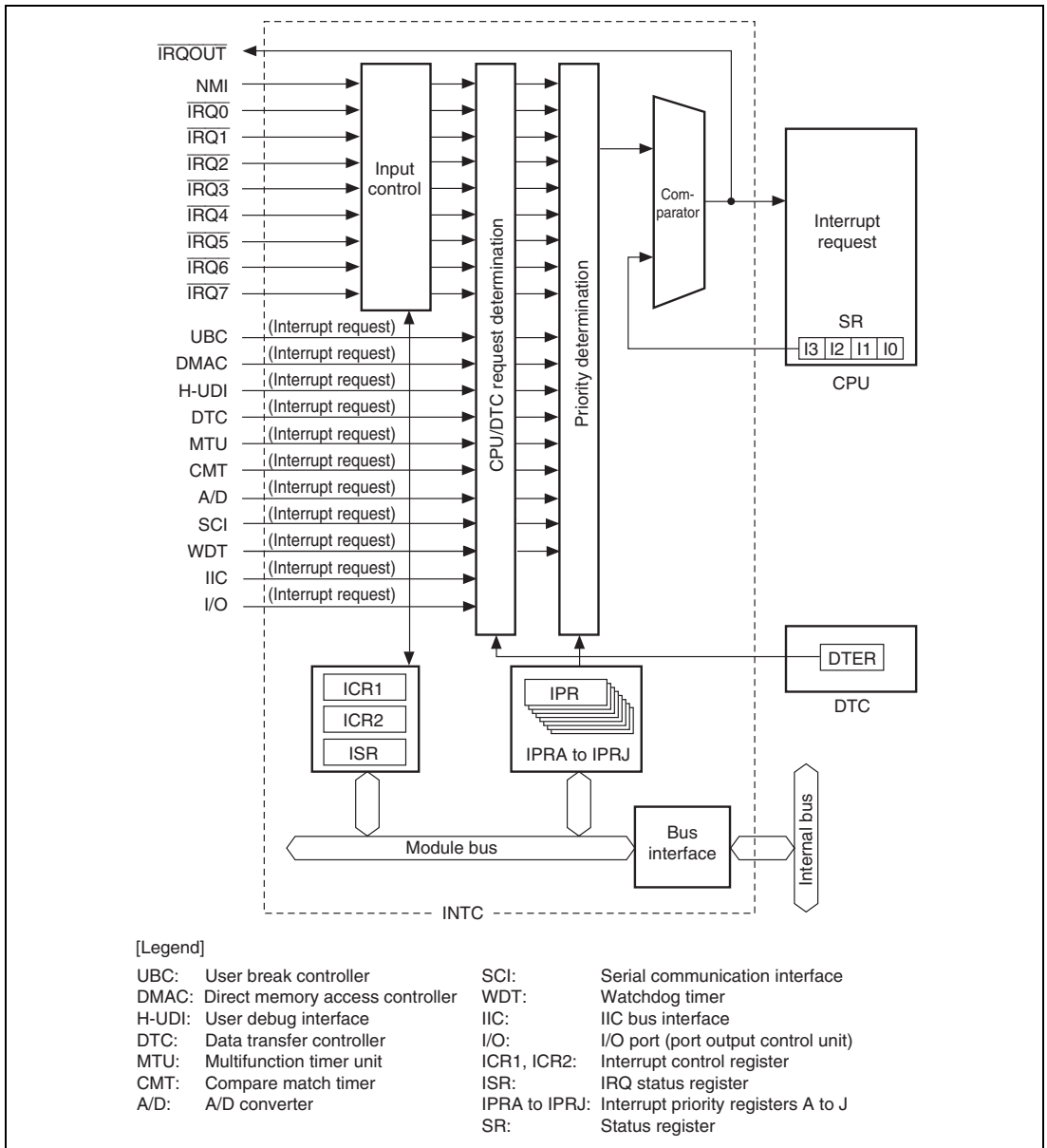

Figure 6.1 INTC Block Diagram

6.2 Input/Output Pins

Table 6.1 shows the INTC pin configuration.

Table 6.1 Pin Configuration

| Name | Abbreviation | I/O | Function |
|----------------------------------|--|-----|--|
| Non-maskable interrupt input pin | NMI | I | Input of non-maskable interrupt request signal |
| Interrupt request input pins | $\overline{\text{IRQ0}}$ to $\overline{\text{IRQ7}}$ | I | Input of maskable interrupt request signals |
| Interrupt request output pin | $\overline{\text{IRQOUT}}$ | O | Output of notification signal when an interrupt has occurred |

6.3 Register Descriptions

The interrupt controller has the following registers. For details on register addresses and register states during each processing, refer to section 25, List of Registers.

- Interrupt control register 1 (ICR1)
- Interrupt control register 2 (ICR2)
- IRQ status register (ISR)
- Interrupt priority register A (IPRA)
- Interrupt priority register B (IPRB)
- Interrupt priority register C (IPRC)
- Interrupt priority register D (IPRD)
- Interrupt priority register E (IPRE)
- Interrupt priority register F (IPRF)
- Interrupt priority register G (IPRG)
- Interrupt priority register H (IPRH)
- Interrupt priority register I (IPRI)
- Interrupt priority register J (IPRJ)

6.3.1 Interrupt Control Register 1 (ICR1)

ICR1 is a 16-bit register that sets the input signal detection mode of the external interrupt input pins NMI and $\overline{\text{IRQ0}}$ to $\overline{\text{IRQ7}}$ and indicates the input signal level at the NMI pin.

| Bit | Bit Name | Initial Value | R/W | Description |
|---------|----------|---------------|-----|---|
| 15 | NMIL | 1/0 | R | <p>NMI Input Level</p> <p>Sets the level of the signal input to the NMI pin. This bit can be read to determine the NMI pin level. This bit cannot be modified.</p> <p>0: NMI input level is low 1: NMI input level is high</p> |
| 14 to 9 | — | All 0 | R | <p>Reserved</p> <p>These bits are always read as 0. The write value should always be 0.</p> |
| 8 | NMIE | 0 | R/W | <p>NMI Edge Select</p> <p>0: Interrupt request is detected on falling edge of NMI input 1: Interrupt request is detected on rising edge of NMI input</p> |
| 7 | IRQ0S | 0 | R/W | <p>IRQ0 Sense Select</p> <p>This bit sets the IRQ0 interrupt request detection mode.</p> <p>0: Interrupt request is detected on low level of $\overline{\text{IRQ0}}$ input 1: Interrupt request is detected on edge of $\overline{\text{IRQ0}}$ input (edge direction is selected by ICR2)</p> |
| 6 | IRQ1S | 0 | R/W | <p>IRQ1 Sense Select</p> <p>This bit sets the IRQ1 interrupt request detection mode.</p> <p>0: Interrupt request is detected on low level of $\overline{\text{IRQ1}}$ input 1: Interrupt request is detected on edge of $\overline{\text{IRQ1}}$ input (edge direction is selected by ICR2)</p> |
| 5 | IRQ2S | 0 | R/W | <p>IRQ2 Sense Select</p> <p>This bit sets the IRQ2 interrupt request detection mode.</p> <p>0: Interrupt request is detected on low level of $\overline{\text{IRQ2}}$ input 1: Interrupt request is detected on edge of $\overline{\text{IRQ2}}$ input (edge direction is selected by ICR2)</p> |

| Bit | Bit Name | Initial Value | R/W | Description |
|-----|----------|---------------|-----|--|
| 4 | IRQ3S | 0 | R/W | <p>IRQ3 Sense Select</p> <p>This bit sets the IRQ3 interrupt request detection mode.</p> <p>0: Interrupt request is detected on low level of $\overline{\text{IRQ3}}$ input</p> <p>1: Interrupt request is detected on edge of $\overline{\text{IRQ3}}$ input (edge direction is selected by ICR2)</p> |
| 3 | IRQ4S | 0 | R/W | <p>IRQ4 Sense Select</p> <p>This bit sets the IRQ4 interrupt request detection mode.</p> <p>0: Interrupt request is detected on low level of $\overline{\text{IRQ4}}$ input</p> <p>1: Interrupt request is detected on edge of $\overline{\text{IRQ4}}$ input (edge direction is selected by ICR2)</p> |
| 2 | IRQ5S | 0 | R/W | <p>IRQ5 Sense Select</p> <p>This bit sets the IRQ5 interrupt request detection mode.</p> <p>0: Interrupt request is detected on low level of $\overline{\text{IRQ5}}$ input</p> <p>1: Interrupt request is detected on edge of $\overline{\text{IRQ5}}$ input (edge direction is selected by ICR2)</p> |
| 1 | IRQ6S | 0 | R/W | <p>IRQ6 Sense Select</p> <p>This bit sets the IRQ6 interrupt request detection mode.</p> <p>0: Interrupt request is detected on low level of $\overline{\text{IRQ6}}$ input</p> <p>1: Interrupt request is detected on edge of $\overline{\text{IRQ6}}$ input (edge direction is selected by ICR2)</p> |
| 0 | IRQ7S | 0 | R/W | <p>IRQ7 Sense Select</p> <p>This bit sets the IRQ7 interrupt request detection mode.</p> <p>0: Interrupt request is detected on low level of $\overline{\text{IRQ7}}$ input</p> <p>1: Interrupt request is detected on edge of $\overline{\text{IRQ7}}$ input (edge direction is selected by ICR2)</p> |

6.3.2 Interrupt Control Register 2 (ICR2)

ICR2 is a 16-bit register that sets the edge detection mode of the external interrupt input pins $\overline{\text{IRQ0}}$ to $\overline{\text{IRQ7}}$. ICR2 is, however, valid only when IRQ interrupt request detection mode is set to the edge detection mode by the sense select bits of IRQ0 to IRQ 7 in Interrupt control register 1 (ICR1). If the IRQ interrupt request detection mode has been set to low level detection mode, the setting of ICR2 is ignored.

| Bit | Bit Name | Initial Value | R/W | Description |
|-----|----------|---------------|-----|---|
| 15 | IRQ0ES1 | 0 | R/W | This bit sets the IRQ0 interrupt request edge detection mode. 00: Interrupt request is detected on falling edge of $\overline{\text{IRQ0}}$ input 01: Interrupt request is detected on rising edge of $\overline{\text{IRQ0}}$ input 10: Interrupt request is detected on both of falling and rising edge of $\overline{\text{IRQ0}}$ input 11: Cannot be set |
| 14 | IRQ0ES0 | 0 | R/W | |
| 13 | IRQ1ES1 | 0 | R/W | |
| 12 | IRQ1ES0 | 0 | R/W | |
| | | | | 00: Interrupt request is detected on falling edge of $\overline{\text{IRQ1}}$ input 01: Interrupt request is detected on rising edge of $\overline{\text{IRQ1}}$ input 10: Interrupt request is detected on both of falling and rising edge of $\overline{\text{IRQ1}}$ input 11: Cannot be set |
| 11 | IRQ2ES1 | 0 | R/W | This bit sets the IRQ2 interrupt request edge detection mode. 00: Interrupt request is detected on falling edge of $\overline{\text{IRQ2}}$ input 01: Interrupt request is detected on rising edge of $\overline{\text{IRQ2}}$ input 10: Interrupt request is detected on both of falling and rising edge of $\overline{\text{IRQ2}}$ input 11: Cannot be set |
| 10 | IRQ2ES0 | 0 | R/W | |
| | | | | |
| | | | | |

| Bit | Bit Name | Initial Value | R/W | Description |
|-----|----------|---------------|-----|---|
| 9 | IRQ3ES1 | 0 | R/W | This bit sets the IRQ3 interrupt request edge detection mode. 00: Interrupt request is detected on falling edge of $\overline{\text{IRQ3}}$ input 01: Interrupt request is detected on rising edge of $\overline{\text{IRQ3}}$ input 10: Interrupt request is detected on both of falling and rising edge of $\overline{\text{IRQ3}}$ input 11: Cannot be set |
| 8 | IRQ3ES0 | 0 | R/W | |
| 7 | IRQ4ES1 | 0 | R/W | |
| 6 | IRQ4ES0 | 0 | R/W | |
| | | | | |
| 5 | IRQ5ES1 | 0 | R/W | This bit sets the IRQ5 interrupt request edge detection mode. 00: Interrupt request is detected on falling edge of $\overline{\text{IRQ5}}$ input 01: Interrupt request is detected on rising edge of $\overline{\text{IRQ5}}$ input 10: Interrupt request is detected on both of falling and rising edge of $\overline{\text{IRQ5}}$ input 11: Cannot be set |
| 4 | IRQ5ES0 | 0 | R/W | |
| 3 | IRQ6ES1 | 0 | R/W | |
| 2 | IRQ6ES0 | 0 | R/W | |
| | | | | |

| Bit | Bit Name | Initial Value | R/W | Description |
|-----|----------|---------------|-----|--|
| 1 | IRQ7ES1 | 0 | R/W | This bit sets the IRQ7 interrupt request edge detection mode. |
| 0 | IRQ7ES0 | 0 | R/W | |
| | | | | 00: Interrupt request is detected on falling edge of $\overline{\text{IRQ7}}$ input |
| | | | | 01: Interrupt request is detected on rising edge of $\overline{\text{IRQ7}}$ input |
| | | | | 10: Interrupt request is detected on both of falling and rising edge of $\overline{\text{IRQ7}}$ input |
| | | | | 11: Cannot be set |

6.3.3 IRQ Status Register (ISR)

ISR is a 16-bit register that indicates the interrupt request status of the external interrupt input pins $\overline{\text{IRQ0}}$ to $\overline{\text{IRQ7}}$. When IRQ interrupts are set to edge detection, held interrupt requests can be cleared by writing 0 to IRQnF after reading $\text{IRQnF} = 1$.

| Bit | Bit Name | Initial Value | R/W | Description |
|---------|----------|---------------|-----|--|
| 15 to 8 | — | All 0 | R | Reserved These bits are always read as 0. The write value should always be 0. |
| 7 | IRQ0F | 0 | R/W | IRQ0 to IRQ7 Flags |
| 6 | IRQ1F | 0 | R/W | These bits display the IRQ0 to IRQ7 interrupt request status. |
| 5 | IRQ2F | 0 | R/W | |
| 4 | IRQ3F | 0 | R/W | [Setting condition] |
| 3 | IRQ4F | 0 | R/W | • When interrupt source that is selected by ICR 1 and ICR2 has occurred. |
| 2 | IRQ5F | 0 | R/W | [Clearing conditions] |
| 1 | IRQ6F | 0 | R/W | |
| 0 | IRQ7F | 0 | R/W | |
| | | | | |
| | | | | • When 0 is written after reading $\text{IRQnF} = 1$ |
| | | | | • When interrupt exception processing has been executed at high level of IRQn input under the low level detection mode. |
| | | | | • When IRQn interrupt exception processing has been executed under the edge detection mode of falling edge, rising edge or both of falling and rising edge. |
| | | | | • When the DISEL bit of DTMR of DTC is 0, after DTC has been started by IRQn interrupt. |

6.3.4 Interrupt Priority Registers A to J (IPRA to IPRJ)

Interrupt priority registers are ten 16-bit readable/writable registers that set priority levels from 0 to 15 for interrupts except NMI. For the correspondence between interrupt request sources and IPR, refer to table 6.2. Each of the corresponding interrupt priority ranks are established by setting a value from H'0 to H'F in each of the four-bit groups 15 to 12, 11 to 8, 7 to 4 and 3 to 0. Reserved bits that are not assigned should be set H'0 (B'0000.)

| Bit | Bit Name | Initial Value | R/W | Description |
|-----|----------|---------------|-----|--|
| 15 | IPR15 | 0 | R/W | These bits set priority levels for the corresponding interrupt source. |
| 14 | IPR14 | 0 | R/W | |
| 13 | IPR13 | 0 | R/W | 0000: Priority level 0 (lowest) |
| 12 | IPR12 | 0 | R/W | 0001: Priority level 1 |
| | | | | 0010: Priority level 2 |
| | | | | 0011: Priority level 3 |
| | | | | 0100: Priority level 4 |
| | | | | 0101: Priority level 5 |
| | | | | 0110: Priority level 6 |
| | | | | 0111: Priority level 7 |
| | | | | 1000: Priority level 8 |
| | | | | 1001: Priority level 9 |
| | | | | 1010: Priority level 10 |
| | | | | 1011: Priority level 11 |
| | | | | 1100: Priority level 12 |
| | | | | 1101: Priority level 13 |
| | | | | 1110: Priority level 14 |
| | | | | 1111: Priority level 15 (highest) |
| 11 | IPR11 | 0 | R/W | These bits set priority levels for the corresponding interrupt source. |
| 10 | IPR10 | 0 | R/W | |
| 9 | IPR9 | 0 | R/W | 0000: Priority level 0 (lowest) |
| 8 | IPR8 | 0 | R/W | 0001: Priority level 1 |
| | | | | 0010: Priority level 2 |
| | | | | 0011: Priority level 3 |
| | | | | 0100: Priority level 4 |
| | | | | 0101: Priority level 5 |
| | | | | 0110: Priority level 6 |
| | | | | 0111: Priority level 7 |
| | | | | 1000: Priority level 8 |
| | | | | 1001: Priority level 9 |
| | | | | 1010: Priority level 10 |
| | | | | 1011: Priority level 11 |
| | | | | 1100: Priority level 12 |
| | | | | 1101: Priority level 13 |
| | | | | 1110: Priority level 14 |
| | | | | 1111: Priority level 15 (highest) |

6. Interrupt Controller (INTC)

| Bit | Bit Name | Initial Value | R/W | Description |
|-----------------------------------|----------|---------------|-----|--|
| 7 | IPR7 | 0 | R/W | These bits set priority levels for the corresponding interrupt source. |
| 6 | IPR6 | 0 | R/W | |
| 5 | IPR5 | 0 | R/W | 0000: Priority level 0 (lowest) |
| 4 | IPR4 | 0 | R/W | 0001: Priority level 1 |
| | | | | 0010: Priority level 2 |
| | | | | 0011: Priority level 3 |
| | | | | 0100: Priority level 4 |
| | | | | 0101: Priority level 5 |
| | | | | 0110: Priority level 6 |
| | | | | 0111: Priority level 7 |
| | | | | 1000: Priority level 8 |
| | | | | 1001: Priority level 9 |
| | | | | 1010: Priority level 10 |
| | | | | 1011: Priority level 11 |
| | | | | 1100: Priority level 12 |
| | | | | 1101: Priority level 13 |
| | | | | 1110: Priority level 14 |
| 1111: Priority level 15 (highest) | | | | |
| 3 | IPR3 | 0 | R/W | These bits set priority levels for the corresponding interrupt source. |
| 2 | IPR2 | 0 | R/W | |
| 1 | IPR1 | 0 | R/W | 0000: Priority level 0 (lowest) |
| 0 | IPR0 | 0 | R/W | 0001: Priority level 1 |
| | | | | 0010: Priority level 2 |
| | | | | 0011: Priority level 3 |
| | | | | 0100: Priority level 4 |
| | | | | 0101: Priority level 5 |
| | | | | 0110: Priority level 6 |
| | | | | 0111: Priority level 7 |
| | | | | 1000: Priority level 8 |
| | | | | 1001: Priority level 9 |
| | | | | 1010: Priority level 10 |
| | | | | 1011: Priority level 11 |
| | | | | 1100: Priority level 12 |
| | | | | 1101: Priority level 13 |
| | | | | 1110: Priority level 14 |
| 1111: Priority level 15 (highest) | | | | |

Note: Name in the tables above is represented by a general name. Name in the list of register is, on the other hand, represented by a module name.

6.4 Interrupt Sources

There are five types of interrupt sources: NMI, user breaks, H-UDI, IRQ, and on-chip peripheral modules. Each interrupt has a priority expressed as a priority level (0 to 16, with 0 the lowest and 16 the highest). Giving an interrupt a priority level of 0 masks it.

6.4.1 External Interrupts

NMI Interrupts: The NMI interrupt has priority 16 and is always accepted. Input at the NMI pin is detected by edge. Use the NMI edge select bit (NMIE) in the interrupt control register 1 (ICR1) to select either the rising or falling edge. NMI interrupt exception processing sets the interrupt mask level bits (I3 to I0) in the status register (SR) to level 15.

IRQ Interrupts: IRQ interrupts are requested by input from pins $\overline{\text{IRQ0}}$ to $\overline{\text{IRQ7}}$. Set the IRQ sense select bits (IRQ0S to IRQ7S) of the interrupt control register 1 (ICR1) and IRQ edge select bit (IRQ0ES[1:0] to IRQ7ES[1:0]) of the interrupt control register 2 (ICR2) to select low level detection, falling edge detection, or rising edge detection for each pin. The priority level can be set from 0 to 15 for each pin using the interrupt priority registers A and B (IPRA and IPRB).

When IRQ interrupts are set to low level detection, an interrupt request signal is sent to the INTC during the period the $\overline{\text{IRQ}}$ pin is low level. Interrupt request signals are not sent to the INTC when the $\overline{\text{IRQ}}$ pin becomes high level. Interrupt request levels can be confirmed by reading the IRQ flags (IRQ0F to IRQ7F) of the IRQ status register (ISR).

When IRQ interrupts are set to falling edge detection, interrupt request signals are sent to the INTC upon detecting a change on the $\overline{\text{IRQ}}$ pin from high to low level. The results of detection for IRQ interrupt request are maintained until the interrupt request is accepted. It is possible to confirm that IRQ interrupt requests have been detected by reading the IRQ flags (IRQ0F to IRQ7F) of the IRQ status register (ISR), and by writing a 0 after reading a 1, IRQ interrupt request detection results can be cleared

In IRQ interrupt exception processing, the interrupt mask bits (I3 to I0) of the status register (SR) are set to the priority level value of the accepted IRQ interrupt. Figure 6.2 shows the block diagram of this IRQ7 to IRQ0 interrupts.

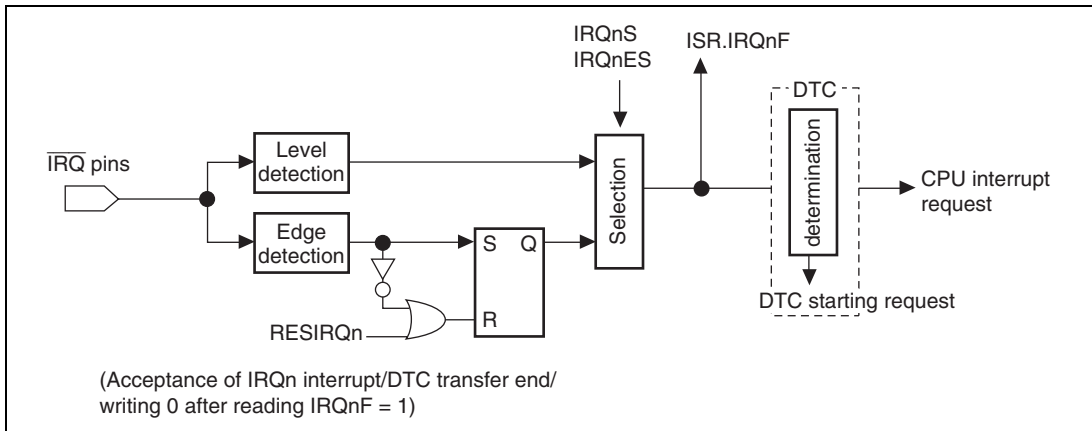

Figure 6.2 Block Diagram of IRQ7 to IRQ0 Interrupts Control

6.4.2 On-Chip Peripheral Module Interrupts

On-chip peripheral module interrupts are interrupts generated by the following on-chip peripheral modules.

As a different interrupt vector is assigned to each interrupt source, the exception service routine does not have to decide which interrupt has occurred. Priority levels between 0 and 15 can be assigned to individual on-chip peripheral modules in interrupt priority registers A to J (IPRA to IPRJ). On-chip peripheral module interrupt exception processing sets the interrupt mask level bits (I3 to I0) in the status register (SR) to the priority level value of the on-chip peripheral module interrupt that was accepted.

6.4.3 User Break Interrupt

A user break interrupt has a priority of level 15, and occurs when the break condition set in the user break controller (UBC) is satisfied. User break interrupt requests are detected by edge and are held until accepted. User break interrupt exception processing sets the interrupt mask level bits (I3 to I0) in the status register (SR) to level 15. For more details on the user break interrupt, see section 7, User Break Controller (UBC).

6.4.4 H-UDI Interrupt

The user debugging interface (H-UDI) interrupt has a priority level of 15, and occurs when an H-UDI interrupt instruction is serially input. H-UDI interrupt requests are detected by edge and are held until accepted. H-UDI exception processing sets the interrupt mask level bits (I3-I0) in the status register (SR) to level 15. For more details on the H-UDI interrupt, see section 22, User Debugging Interface (H-UDI).

6.5 Interrupt Exception Processing Vectors Table

Table 6.2 lists interrupt sources and their vector numbers, vector table address offsets and interrupt priorities.

Each interrupt source is allocated a different vector number and vector table address offset. Vector table addresses are calculated from the vector numbers and address offsets. In interrupt exception processing, the exception service routine start address is fetched from the vector table indicated by the vector table address. For the details of calculation of vector table address, see table 5.4.

IRQ interrupts and on-chip peripheral module interrupt priorities can be set freely between 0 and 15 for each pin or module by setting interrupt priority registers A to J (IPRA to IPRJ). However, the smaller vector number has interrupt source, the higher priority ranking is assigned among two or more interrupt sources specified by the same IPR, and the priority ranking cannot be changed. A power-on reset assigns priority level 0 to IRQ interrupts and on-chip peripheral module interrupts. If the same priority level is assigned to two or more interrupt sources and interrupts from those sources occur simultaneously, they are processed by the default priority order indicated in table 6.2.

Table 6.2 Interrupt Exception Processing Vectors and Priorities

| Interrupt Source | Name | Vector No. | Vector Table Starting Address | IPR | Default Priority |
|------------------|--------------------|------------|-------------------------------|------------------|------------------|
| External pin | NMI | 11 | H'0000002C | — | High ↑ Low |
| User break | | 12 | H'00000030 | — | |
| H-UDI | | 14 | H'00000038 | — | |
| — | Reserved by system | 15 | H'0000003C | — | |
| Interrupts | IRQ0 | 64 | H'00000100 | IPRA15 to IPRA12 | |
| | IRQ1 | 65 | H'00000104 | IPRA11 to IPRA8 | |
| | IRQ2 | 66 | H'00000108 | IPRA7 to IPRA4 | |
| | IRQ3 | 67 | H'0000010C | IPRA3 to IPRA0 | |
| | IRQ4 | 68 | H'00000110 | IPRB15 to IPRB12 | |
| | IRQ5 | 69 | H'00000114 | IPRB11 to IPRB8 | |
| | IRQ6 | 70 | H'00000118 | IPRB7 to IPRB4 | |
| | IRQ7 | 71 | H'0000011C | IPRB3 to IPRB0 | |

6. Interrupt Controller (INTC)

| Interrupt Source | Name | Vector No. | Vector Table Starting Address | IPR | Default Priority |
|------------------|--------------------|------------|-------------------------------|------------------|------------------|
| SCI channel 1 | ERI_1 | 132 | H'00000210 | IPRF3 to IPRF0 | High |
| | RXI_1 | 133 | H'00000214 | | |
| | TXI_1 | 134 | H'00000218 | | |
| | TEI_1 | 135 | H'0000021C | | |
| A/D | ADI0 | 136 | H'00000220 | IPRG15 to IPRG12 | |
| | ADI1 | 137 | H'00000224 | | |
| DTC | SWDTEND | 140 | H'00000230 | IPRG11 to IPRG8 | |
| CMT | CMI0 | 144 | H'00000240 | IPRG7 to IPRG4 | |
| | CMI1 | 148 | H'00000250 | | |
| Watchdog timer | ITI | 152 | H'00000260 | IPRH15 to IPRH12 | |
| — | Reserved by system | 153 | H'00000264 | — | |
| I/O (MTU) | MTUOEI | 156 | H'00000270 | IPRH11 to IPRH8 | |
| — | Reserved by system | 160 to 167 | H'00000290 to H'0000029C | — | |
| SCI channel 2 | ERI_2 | 168 | H'000002A0 | IPRI15 to IPRI12 | |
| | RXI_2 | 169 | H'000002A4 | | |
| | TXI_2 | 170 | H'000002A8 | | |
| | TEI_2 | 171 | H'000002AC | | |
| SCI channel 3 | ERI_3 | 172 | H'000002B0 | IPRI11 to IPRI8 | |
| | RXI_3 | 173 | H'000002B4 | | |
| | TXI_3 | 174 | H'000002B8 | | |
| | TEI_3 | 175 | H'000002BC | | |
| — | Reserved by system | 176 to 188 | H'000002C0 to H'000002FC | — | |
| IIC | ICI | 192 | H'00000300 | IPRJ7 to IPRJ4 | |
| — | Reserved by system | 196 to 247 | H'00000304 to H'000003DC | | Low |

6.6 Operation

6.6.1 Interrupt Sequence

The sequence of interrupt operations is explained below. Figure 6.3 is a flowchart of the operations.

1. The interrupt request sources send interrupt request signals to the interrupt controller.
2. The interrupt controller selects the highest priority interrupt in the interrupt requests sent, according to the priority levels set in interrupt priority level setting registers A to J (IPRA to IPRJ). Interrupts that have lower-priority than that of the selected interrupt are ignored.* If interrupts that have the same priority level or interrupts within a same module occur simultaneously, the interrupt with the highest priority is selected according to the default priority order indicated in table 6.2.
3. The interrupt controller compares the priority level of the selected interrupt request with the interrupt mask bits (I3 to I0) in the CPU's status register (SR). If the request priority level is equal to or less than the level set in I3 to I0, the request is ignored. If the request priority level is higher than the level in bits I3 to I0, the interrupt controller accepts the interrupt and sends an interrupt request signal to the CPU.
4. When the interrupt controller accepts an interrupt, a low level is output from the $\overline{\text{IRQOUT}}$ pin.
5. The CPU detects the interrupt request sent from the interrupt controller when CPU decodes the instruction to be executed. Instead of executing the decoded instruction, the CPU starts interrupt exception processing (figure 6.5).
6. SR and PC are saved onto the stack.
7. The priority level of the accepted interrupt is copied to the interrupt mask level bits (I3 to I0) in the status register (SR).
8. When the accepted interrupt is sensed by level or is from an on-chip peripheral module, a high level is output from the $\overline{\text{IRQOUT}}$ pin. When the accepted interrupt is sensed by edge, a high level is output from the $\overline{\text{IRQOUT}}$ pin at the moment when the CPU starts interrupt exception processing instead of instruction execution as noted in (5) above. However, if the interrupt controller accepts an interrupt with a higher priority than the interrupt just to be accepting, the $\overline{\text{IRQOUT}}$ pin holds low level.
9. The CPU reads the start address of the exception service routine from the exception vector table for the accepted interrupt, jumps to that address, and starts executing the program. This jump is not a delay branch.

Note: * Interrupt requests that are designated as edge-detect type are held pending until the interrupt requests are accepted. IRQ interrupts, however, can be cancelled by accessing

the IRQ status register (ISR). Interrupts held pending due to edge detection are cleared by a power-on reset or a manual reset.

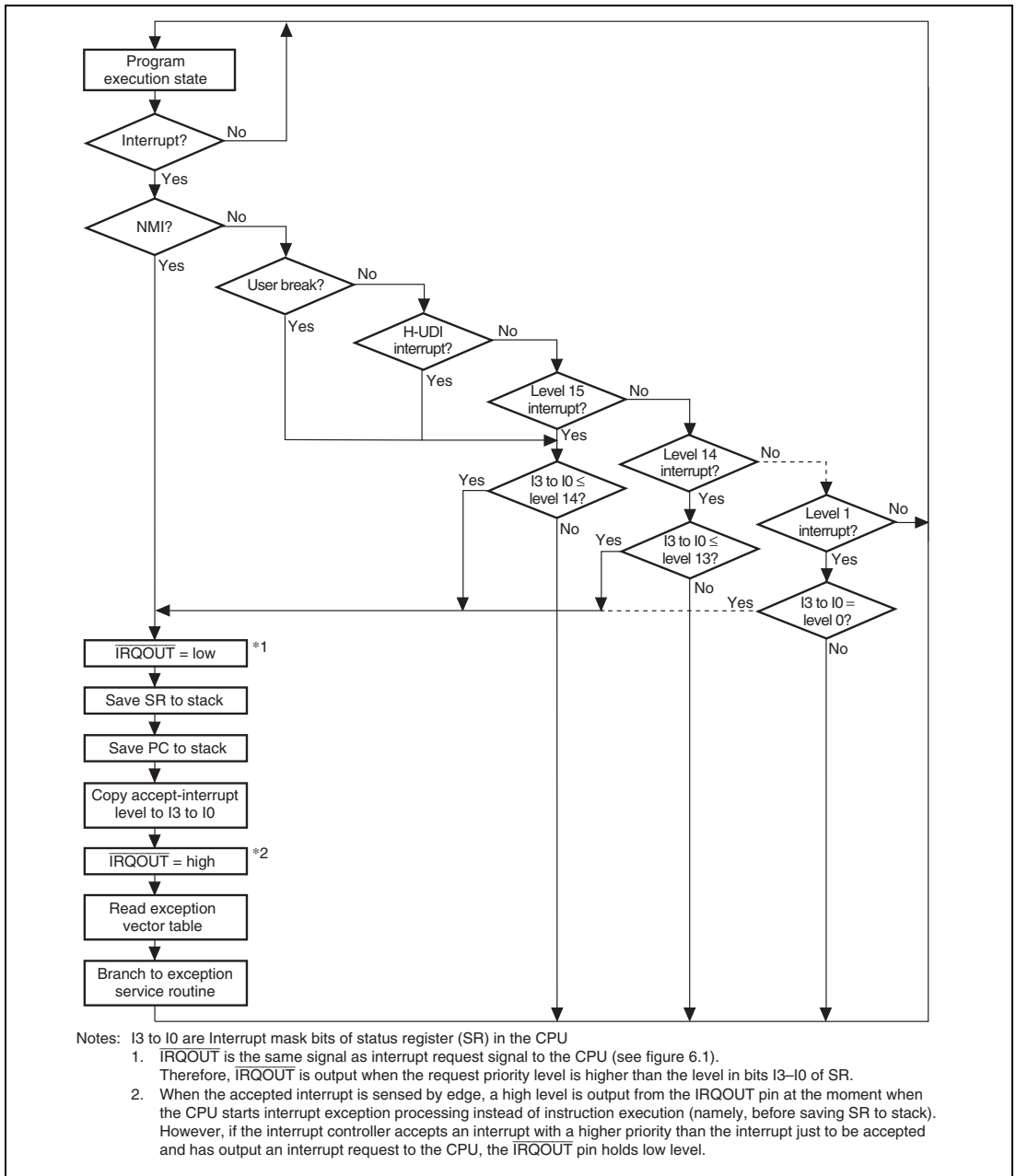
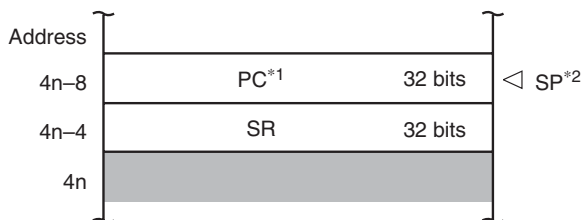

Figure 6.3 Interrupt Sequence Flowchart

6.6.2 Stack after Interrupt Exception Processing

Figure 6.4 shows the stack after interrupt exception processing.



- Notes:
1. PC: Start address of the next instruction (return destination instruction) after the executing instruction
 2. Always make sure that SP is a multiple of 4

Figure 6.4 Stack after Interrupt Exception Processing

6.7 Interrupt Response Time

Table 6.3 lists the interrupt response time, which is the time from the occurrence of an interrupt request until the interrupt exception processing starts and fetching of the first instruction of the interrupt service routine begins. Figure 6.5 shows an example of the pipeline operation when an IRQ interrupt is accepted.

Table 6.3 Interrupt Response Time

| Item | Number of States | | Remarks |
|--|---|-----------------------------|---|
| | NMI, Peripheral Module | IRQ | |
| DMAC/DTC active judgment | 0 or 1 | 1 | 1 state required for interrupt signals for which DMAC/DTC activation is possible |
| Interrupt priority judgment and comparison with SR mask bits | 2 | 3 | |
| Wait for completion of sequence currently being executed by CPU | $X (\geq 0)$ | $X (\geq 0)$ | The longest sequence is for interrupt or address-error exception processing ($X = 4 + m1 + m2 + m3 + m4$). If an interrupt-masking instruction follows, however, the time may be even longer. |
| Time from start of interrupt exception processing until fetch of first instruction of exception service routine starts | $5 + m1 + m2 + m3$ | $5 + m1 + m2 + m3$ | Performs the saving PC and SR, and vector address fetch. |
| Interrupt response time | Total: $(7 \text{ or } 8) + m1 + m2 + m3 + X$ | $9 + m1 + m2 + m3 + X$ | |
| | Minimum: 10 | 12 | 0.20 to 0.24 μs at 50 MHz |
| | Maximum: $12 + 2(m1 + m2 + m3) + m4$ | $13 + 2(m1 + m2 + m3) + m4$ | 0.38 to 0.40 μs at 50 MHz* |

Note: $m1$ to $m4$ are the number of states needed for the following memory accesses.

$m1$: SR save (longword write)

$m2$: PC save (longword write)

$m3$: Vector address read (longword read)

$m4$: Fetch first instruction of interrupt service routine

* 0.38 to 0.40 μs at 50 MHz is the value in the case that $m1 = m2 = m3 = m4 = 1$.

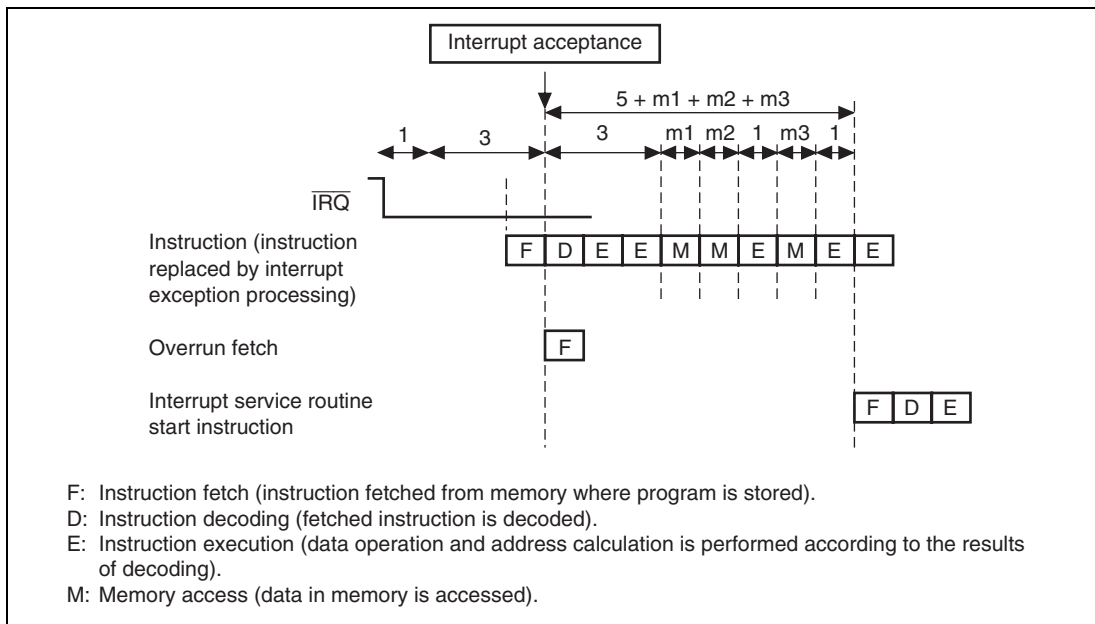

Figure 6.5 Example of Pipeline Operation when IRQ Interrupt Is Accepted

6.8 Data Transfer with Interrupt Request Signals

The following data transfers can be done using interrupt request signals:

- Activate DMAC only, CPU interrupts do not occur
- Activate DTC only, CPU interrupts according to DTC settings

Interrupt sources that are activated by DMAC are masked without being input to INTC. Mask condition is as follows:

Mask condition = $DME \bullet (DE0 \bullet \text{interrupt source select } 0 + DE1 \bullet \text{interrupt source select } 1 + DE2 \bullet \text{interrupt source select } 2 + DE3 \bullet \text{interrupt source select } 3)$

The INTC masks CPU interrupts when the corresponding DTE bit is 1. The conditions for clearing DTE and interrupt source flag are listed below.

DTE clear condition = $DTC \text{ transfer end} \bullet DTECLR$

Interrupt source flag clear condition = $DTC \text{ transfer end} \bullet \overline{DTECLR} + DMAC \text{ transfer end}$

Where: $DTECLR = DISEL + \text{counter } 0$.

Figure 6.6 shows a control block diagram.

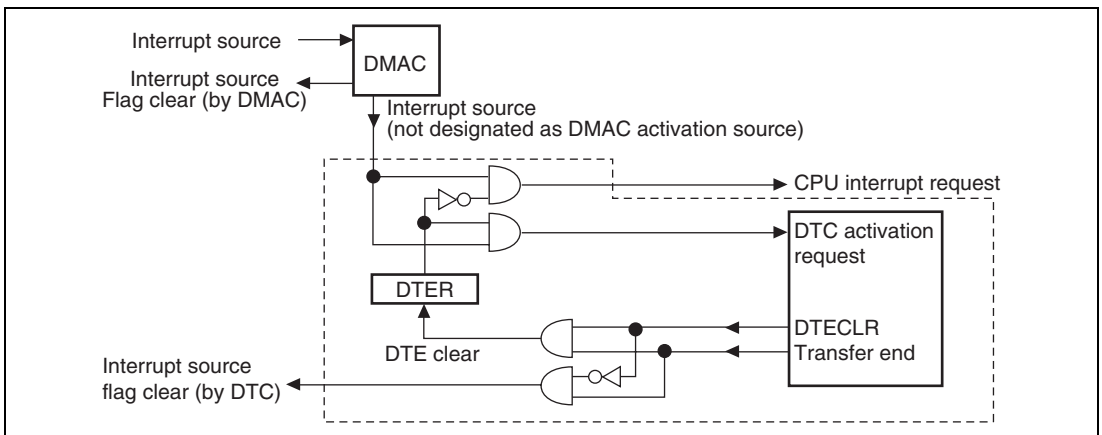

Figure 6.6 Interrupt Control Block Diagram

6.8.1 Handling Interrupt Request Signals as Sources for DTC Activating and CPU Interrupt, but Not DMAC Activating

1. Do not select DMAC activating sources or clear the DTE bit to 0.
2. For DTC, set the corresponding DTE bits and DIESEL bits to 1.
3. Activating sources are applied to the DTC when interrupts occur.
4. When the DTC performs a data transfer, it clears the DTE bit to 0 and sends an interrupt request to the CPU. The activating source is not cleared.
5. The CPU clears interrupt sources in the interrupt processing routine then confirms the transfer counter value. When the transfer counter value is not 0, the CPU sets the DTE bit to 1 and allows the next data transfer. If the transfer counter value = 0, the CPU performs the necessary end processing in the interrupt processing routine.

6.8.2 Handling Interrupt Request Signals as Sources for Activating DMAC, but Not CPU Interrupt and DTC Activating

1. Select DMAC activating sources and set the DME bit to 1. Then, CPU interrupt and DTC activating sources are masked regardless of the settings of the interrupt priority register and the DTC register.
2. Activating sources are applied to the DMAC when interrupts occur.
3. The DMAC clears the interrupt sources when starting transfer.

6.8.3 Handling Interrupt Request Signals as Source for DTC Activating, but Not CPU Interrupt and DMAC Activating

1. Do not select DMAC activating sources or clear the DME bit to 0.
2. For DTC, set the corresponding DTE bits to 1 and clear the DIESEL bits to 0.
3. Activating sources are applied to the DTC when interrupts occur.
4. When the DTC performs a data transfer, it clears the activating source. An interrupt request is not sent to the CPU, because the DTE bit is hold to 1.
5. However, when the transfer counter value = 0 the DTE bit is cleared to 0 and an interrupt request is sent to the CPU.
6. The CPU performs the necessary end processing in the interrupt processing routine.

6.8.4 Handling Interrupt Request Signals as Source for CPU Interrupt but Not DMAC and DTC Activating

- 1 Do not select DMAC activating sources or clear the DME bit to 0.
2. For DTC, clear the corresponding DTE bits to 0.
3. When interrupts occur, interrupt requests are sent to the CPU.
4. The CPU clears the interrupt source and performs the necessary processing in the interrupt processing routine.

Section 7 User Break Controller (UBC)

The user break controller (UBC) provides functions that make program debugging easier. By setting break conditions in the UBC, a user break interrupt is generated according to the contents of the bus cycle generated by the CPU or DMAC/DTC. This function makes it easy to design an effective self-monitoring debugger, and customers of the chip can easily debug their programs without using a large in-circuit emulator.

7.1 Features

- There are 5 types of break compare conditions as follows:
 - Address
 - CPU cycle or DMAC/DTC cycle
 - Instruction fetch or data access
 - Read or write
 - Operand size: longword/word/byte
- User break interrupt generated upon satisfying break conditions
- User break interrupt generated before an instruction is executed by selecting break in the CPU instruction fetch.
- Module standby mode can be set

Figure 7.1 shows a block diagram of the UBC.

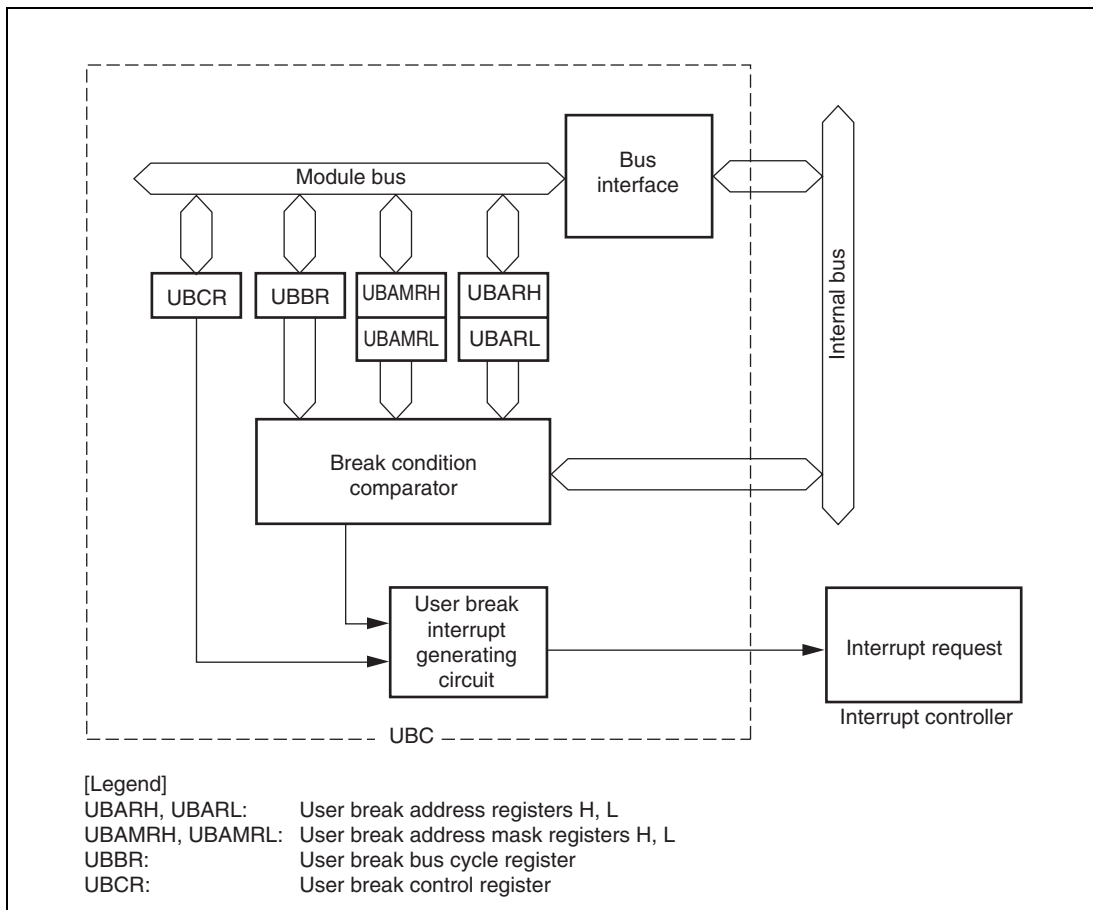

Figure 7.1 User Break Controller Block Diagram

7.2 Register Descriptions

The UBC has the following registers. For details on register addresses and register states during each processing, refer to section 25, List of Registers.

- User break address register H (UBARH)
- User break address register L (UBARL)
- User break address mask register H (UBAMRH)
- User break address mask register L (UBAMRL)
- User break bus cycle register (UBBR)
- User break control register (UBCR)

7.2.1 User Break Address Register (UBAR)

The user break address register (UBAR) consists of two registers: user break address register H (UBARH) and user break address register L (UBARL). Both are 16-bit readable/writable registers. UBARH specifies the upper bits (bits 31 to 16) of the address for the break condition, while UBARL specifies the lower bits (bits 15 to 0).

The initial value of UBAR is H'00000000.

- UBARH Bits 15 to 0: specifies user break address 31 to 16 (UBA31 to UBA16)
- UBARL Bits 15 to 0: specifies user break address 15 to 0 (UBA15 to UBA0)

7.2.2 User Break Address Mask Register (UBAMR)

The user break address mask register (UBAMR) consists of two registers: user break address mask register H (UBAMRH) and user break address mask register L (UBAMRL). Both are 16-bit readable/writable registers. UBAMRH specifies whether to mask any of the break address bits set in UBARH, and UBAMRL specifies whether to mask any of the break address bits set in UBARL.

- UBAMRH Bits 15 to 0: specifies user break address mask 31 to 16 (UBM31 to UBM16)
- UBAMRL Bits 15 to 0: specifies user break address mask 15 to 0 (UBM15 to UBM0)

7. User Break Controller (UBC)

| Bit | Bit Name | Initial Value | R/W | Description |
|------------------------|-------------------|---------------|-----|--|
| UBAMRH15 to UBAMRH0 | UBM31 to UBM16 | All 0 | R/W | User Break Address Mask 31 to 16 0: Corresponding UBA bit is included in the break conditions 1: Corresponding UBA bit is not included in the break conditions |
| UBAMRL15 to UBAMRL0 | UBM15 to UBM0 | All 0 | R/W | User Break Address Mask 15 to 0 0: Corresponding UBA bit is included in the break conditions 1: Corresponding UBA bit is not included in the break conditions |

7.2.3 User Break Bus Cycle Register (UBBR)

The user break bus cycle register (UBBR) is a 16-bit readable/writable register that sets the four break conditions.

| Bit | Bit Name | Initial Value | R/W | Description |
|---------|----------|---------------|-----|--|
| 15 to 8 | — | All 0 | R | Reserved These bits are always read as 0. The write value should always be 0. |
| 7 | CP1 | 0 | R/W | CPU Cycle/DMAC, DTC Cycle Select 1 and 0 |
| 6 | CP0 | 0 | R/W | These bits specify break conditions for CPU cycles or DMAC/DTC cycles. 00: No user break interrupt occurs 01: Break on CPU cycles 10: Break on DTC or DMAC cycles 11: Break on both CPU and DMAC or DTC cycles |
| 5 | ID1 | 0 | R/W | Instruction Fetch/Data Access Select1 and 0 |
| 4 | ID0 | 0 | R/W | These bits select whether to break on instruction fetch and/or data access cycles. 00: No user break interrupt occurs 01: Break on instruction fetch cycles 10: Break on data access cycles 11: Break on both instruction fetch and data access cycles |

| Bit | Bit Name | Initial Value | R/W | Description |
|-----|----------|---------------|-----|--|
| 3 | RW1 | 0 | R/W | Read/Write Select 1 and 0 |
| 2 | RW0 | 0 | R/W | These bits select whether to break on read and/or write cycles 00: No user break interrupt occurs 01: Break on read cycles 10: Break on write cycles 11: Break on both read and write cycles |
| 1 | SZ1 | 0 | R/W | Operand Size Select 1 and 0* |
| 0 | SZ0 | 0 | R/W | These bits select operand size as a break condition. 00: Operand size is not a break condition 01: Break on byte access 10: Break on word access 11: Break on longword access |

Note: * When breaking on an instruction fetch, clear the SZ0 bit to 0. All instructions are considered to be accessed in word-size (even when there are instructions in on-chip memory and two instruction fetches are performed simultaneously in one bus cycle). Operand size is word for instructions or determined by the operand size specified for the CPU/DTC, DMAC data access. It is not determined by the bus width of the space being accessed.

7.2.4 User Break Control Register (UBCR)

The user break control register (UBCR) is a 16-bit readable/writable register that enables or disables user break interrupts.

| Bit | Bit Name | Initial Value | R/W | Description |
|---------|----------|---------------|-----|--|
| 15 to 1 | — | All 0 | R | Reserved These bits are always read as 0. The write value should always be 0. |
| 0 | UBID | 0 | R/W | User Break Disable Enables or disables user break interrupt request generation in the event of a user break condition match. 0: User break interrupt request is enabled 1: User break interrupt request is disabled |

7.3 Operation

7.3.1 Flow of User Break Operation

The flow from setting of break conditions to user break interrupt exception processing is described below:

1. The user break addresses are set in the user break address register (UBAR), the desired masked bits in the addresses are set in the user break address mask register (UBAMR) and the breaking bus cycle type is set in the user break bus cycle register (UBBR). If even one of the three groups of the UBBR's CPU cycle/DMAC, DTC cycle select bits (CP1, CP0), instruction fetch/data access select bits (ID1, ID0), and read/write select bits (RW1, RW0) is set to 00 (no user break generated), no user break interrupt will be generated even if all other conditions are satisfied. When using user break interrupts, always be certain to establish bit conditions for all of these three groups.
2. The UBC uses the method shown in figure 7.2 to determine whether set conditions have been satisfied or not. When the set conditions are satisfied, the UBC sends a user break interrupt request signal to the interrupt controller (INTC).
3. The interrupt controller checks the accepted user break interrupt request signal's priority level. The user break interrupt has priority level 15, so it is accepted only if the interrupt mask level in bits I3 to I0 in the status register (SR) is 14 or lower. When the I3 to I0 bit level is 15, the user break interrupt cannot be accepted but it is held pending until user break interrupt exception processing can be carried out. Consequently, user break interrupts within NMI exception service routines cannot be accepted, since the I3 to I0 bit level is 15. However, if the I3 to I0 bit level is changed to 14 or lower at the start of the NMI exception service routine, user break interrupts become acceptable thereafter. See section 6, Interrupt Controller (INTC), for the details on the handling of priority levels.
4. The INTC sends the user break interrupt request signal to the CPU, which begins user break interrupt exception processing upon receipt. See section 6.6, Operation, for the details on interrupt exception processing.

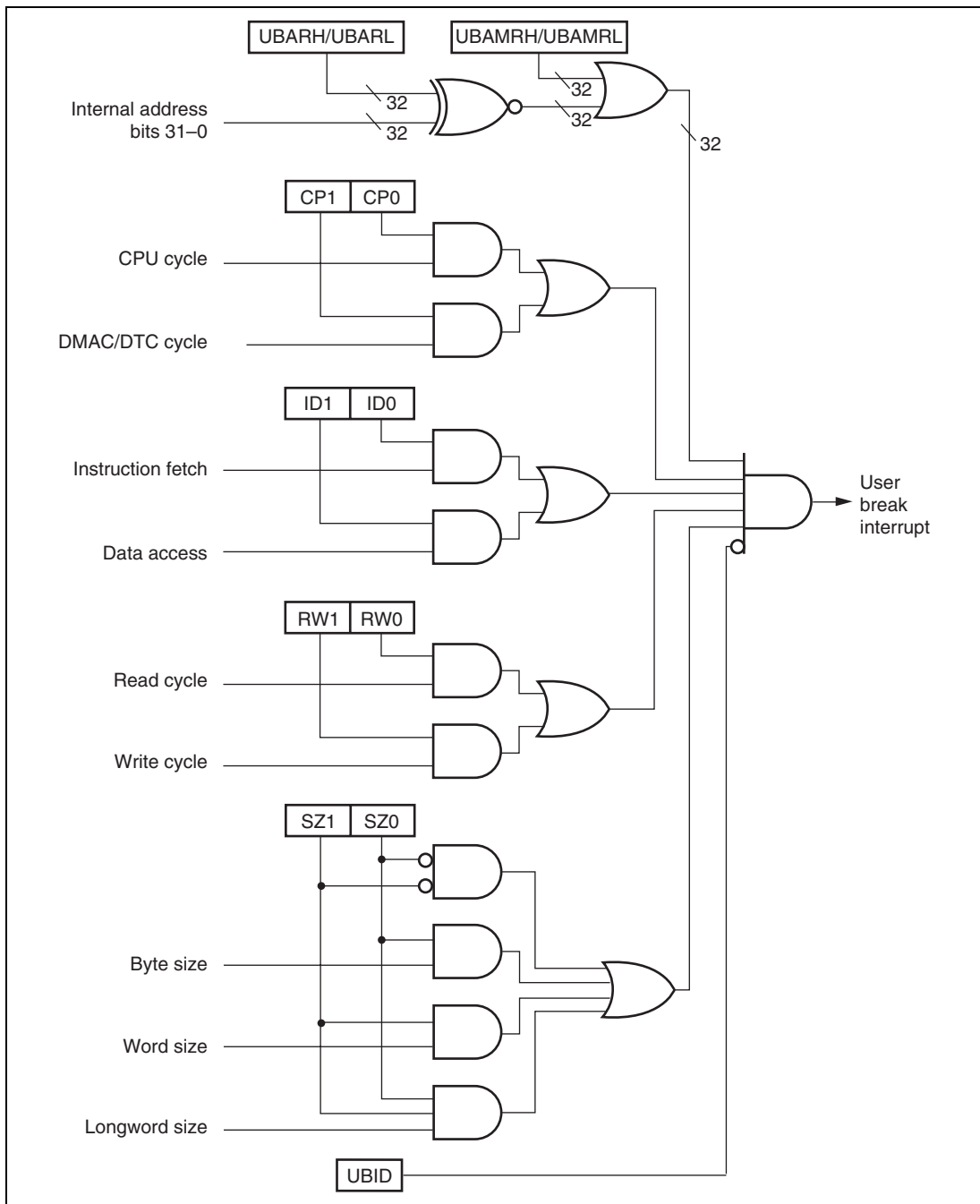

Figure 7.2 Break Condition Determination Method

7.3.2 Break on On-Chip Memory Instruction Fetch Cycle

Data in on-chip memory (on-chip ROM and/or RAM) is always accessed as 32-bits data in one bus cycle. Therefore, two instructions can be retrieved in one bus cycle when fetching instructions from on-chip memory. At such times, only one bus cycle is generated, but it is possible to cause independent breaks by setting the start addresses of both instructions in the user break address register (UBAR). In other words, when wanting to effect a break using the latter of two addresses retrieved in one bus cycle, set the start address of that instruction in UBAR. The break will occur after execution of the former instruction.

7.3.3 Program Counter (PC) Values Saved

Break on Instruction Fetch: The program counter (PC) value saved to the stack in user break interrupt exception processing is the address that matches the break condition. The user break interrupt is generated before the fetched instruction is executed. If a break condition is set in an instruction fetch cycle placed immediately after a delayed branch instruction (delay slot), or on an instruction that follows an interrupt-disabled instruction, however, the user break interrupt is not accepted immediately, but the break condition establishing instruction is executed. The user break interrupt is accepted after execution of the instruction that has accepted the interrupt. In this case, the PC value saved is the start address of the instruction that will be executed after the instruction that has accepted the interrupt.

Break on Data Access (CPU/DTC, DMAC): The program counter (PC) value is the top address of the next instruction after the last instruction executed before the user break exception processing started. When data access (CPU/DTC, DMAC) is set as a break condition, the place where the break will occur cannot be specified exactly. The break will occur at the instruction fetched close to where the data access that is to receive the break occurs.

7.4 Examples of Use

Break on CPU Instruction Fetch Cycle

1. Register settings: UBARH = H'0000
UBARL = H'0404
UBBR = H'0054
UBCR = H'0000

Conditions set: Address: H'00000404
Bus cycle: CPU, instruction fetch, read
(operand size is not included in conditions)
Interrupt requests enabled

A user break interrupt will occur before the instruction at address H'00000404. If it is possible for the instruction at H'00000402 to accept an interrupt, the user break exception processing will be executed after execution of that instruction. The instruction at H'00000404 is not executed. The PC value saved is H'00000404.

2. Register settings: UBARH = H'0015
UBARL = H'389C
UBBR = H'0058
UBCR = H'0000

Conditions set: Address: H'0015389C
Bus cycle: CPU, instruction fetch, write
(operand size is not included in conditions)
Interrupt requests enabled

A user break interrupt does not occur because the instruction fetch cycle is not a write cycle.

3. Register settings: UBARH = H'0003
UBARL = H'0147
UBBR = H'0054
UBCR = H'0000

Conditions set: Address: H'00030147
Bus cycle: CPU, instruction fetch, read
(operand size is not included in conditions)
Interrupt requests enabled

A user break interrupt does not occur because the instruction fetch was performed for an even address. However, if the first instruction fetch address after the branch is an odd address set by these conditions, user break interrupt exception processing will be carried out after address error exception processing.

Break on CPU Data Access Cycle

1. Register settings: UBARH = H'0012
UBARL = H'3456
UBBR = H'006A
UBCR = H'0000

Conditions set: Address: H'00123456
Bus cycle: CPU, data access, write, word
Interrupt requests enabled

A user break interrupt occurs when word data is written into address H'00123456.

2. Register settings: UBARH = H'00A8
UBARL = H'0391
UBBR = H'0066
UBCR = H'0000

Conditions set: Address: H'00A80391
Bus cycle: CPU, data access, read, word
Interrupt requests enabled

A user break interrupt does not occur because the word access was performed on an even address.

Break on DMAC/DTC Cycle

1. Register settings: UBARH = H'0076
UBARL = H'BCDC
UBBR = H'00A7
UBCR = H'0000

Conditions set: Address: H'0076BCDC
Bus cycle: DMAC/DTC, data access, read, longword
Interrupt requests enabled

A user break interrupt occurs when longword data is read from address H'0076BCDC.

2. Register settings: UBARH = H'0023
UBARL = H'45C8
UBBR = H'0094
UBCR = H'0000

Conditions set: Address: H'002345C8
Bus cycle: DMAC/DTC, instruction fetch, read
(operand size is not included in conditions)
Interrupt requests enabled

A user break interrupt does not occur because no instruction fetch is performed in the DMAC/DTC cycle.

7.5 Usage Notes

7.5.1 Simultaneous Fetching of Two Instructions

Two instructions may be simultaneously fetched in instruction fetch operation. Once a break condition is set on the latter of these two instructions, a user break interrupt will occur before the latter instruction, even though the contents of the UBC registers are modified to change the break conditions immediately after the fetching of the former instruction.

7.5.2 Instruction Fetches at Branches

When a conditional branch instruction or TRAPA instruction causes a branch, the order of instruction fetching and execution is as follows:

1. When branching with a conditional branch instruction: BT and BF instructions
When branching with a TRAPA instruction: TRAPA instruction
 - a. Instruction fetch order
Branch instruction fetch → next instruction overrun fetch → overrun fetch of instruction after the next → branch destination instruction fetch
 - b. Instruction execution order
Branch instruction execution → branch destination instruction execution
2. When branching with a delayed conditional branch instruction: BT/S and BF/S instructions
 - a. Instruction fetch order
Branch instruction fetch → next instruction fetch (delay slot) → overrun fetch of instruction after the next → branch destination instruction fetch
 - b. Instruction execution order
Branch instruction execution → delay slot instruction execution → branch destination instruction execution

Thus, when a conditional branch instruction or TRAPA instruction causes a branch, the branch destination instruction will be fetched after an overrun fetch of the next instruction or the instruction after the next. However, as the instruction that is the object of the break does not break until fetching and execution of the instruction have been confirmed, the overrun fetches described above do not become objects of a break.

If data accesses are also included in break conditions besides instruction fetch, a break will occur because the instruction overrun fetch is also regarded as satisfying the data break condition.

7.5.3 Contention between User Break and Exception Processing

If a user break is set for the fetch of a particular instruction, and exception processing with higher priority than a user break is in contention and is accepted in the decode stage for that instruction (or the next instruction), user break exception processing may not be performed after completion of the higher-priority exception service routine (on return by RTE).

Thus, if a user break condition is specified to the branch destination instruction fetch after a branch (BRA, BRAF, BT, BF, BT/S, BF/S, BSR, BSRF, JMP, JSR, RTS, RTE, exception processing), and that branch instruction accepts an exception processing with higher priority than a user break interrupt, user break exception processing is not performed after completion of the exception service routine.

Therefore, a user break condition should not be set for the fetch of the branch destination instruction after a branch.

7.5.4 Break at Non-Delay Branch Instruction Jump Destination

When a branch instruction without delay slot (including exception processing) jumps to the destination instruction by executing the branch, a user break will not be generated even if a user break condition has been set for the first jump destination instruction fetch.

7.5.5 Module Standby Mode Setting

The UBC can set the module disable/enable by using the module standby control register 2 (MSTCR2). By releasing the module standby mode, register access becomes to be enabled.

By setting the MSTP0 bit of MSTCR2 to 1, the UBC is in the module standby mode in which the clock supply is halted. See section 24, Power-Down Modes, for further details.

Section 8 Data Transfer Controller (DTC)

This LSI includes a data transfer controller (DTC). The DTC can be activated by an interrupt or software, to transfer data.

Figure 8.1 shows a block diagram of the DTC.

The DTC's register information is stored in the on-chip RAM. When the DTC is used, the RAME bit in SYSCR must be set to 1.

8.1 Features

- Transfer possible over any number of channels
- Three transfer modes
Normal, repeat, and block transfer modes available
- One activation source can trigger a number of data transfers (chain transfer)
- Direct specification of 32-bit address space possible
- Activation by software is possible
- Transfer can be set in byte, word, or longword units
- The interrupt that activated the DTC can be requested to the CPU
- Module standby mode can be set

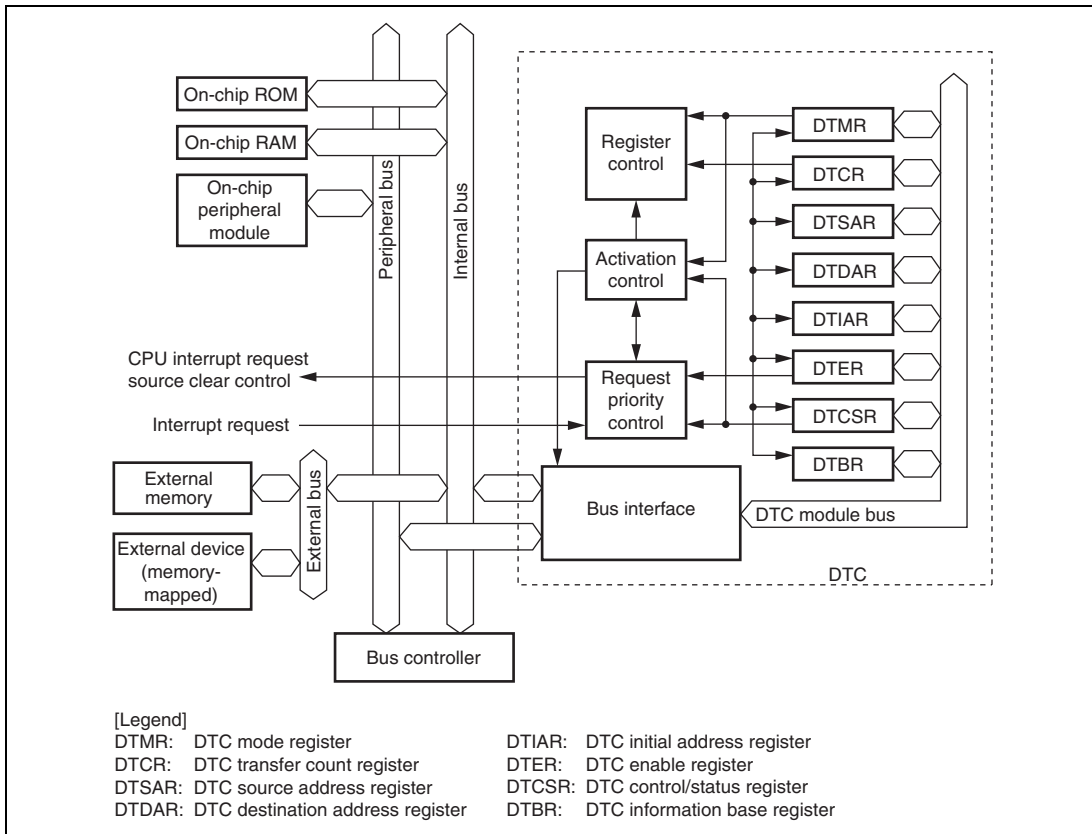

Figure 8.1 Block Diagram of DTC

8.2 Register Descriptions

The DTC has the following registers.

- DTC mode register (DTMR)
- DTC source address register (DTSAR)
- DTC destination address register (DTDAR)
- DTC initial address register (DTIAR)
- DTC transfer count register A (DTCRA)
- DTC transfer count register B (DTCRB)

These six registers cannot be directly accessed from the CPU.

When activated, the DTC transfer desired set of register information that is stored in an on-chip RAM to the corresponding DTC registers. After the data transfer, it writes a set of updated register information back to the RAM.

- DTC enable register A (DTEA)
- DTC enable register B (DTEB)
- DTC enable register C (DTEC)
- DTC enable register D (DTED)
- DTC enable register E (DTEE)
- DTC enable register G (DTEG)
- DTC control/status register (DTCSR)
- DTC information base register (DTBR)

For details on register addresses and register states during each processing, refer to section 25, List of Registers.

8.2.1 DTC Mode Register (DTMR)

DTMR is a 16-bit register that selects the DTC operating mode.

| Bit | Bit Name | Initial Value | R/W | Description |
|-----|----------|---------------|-----|---|
| 15 | SM1 | Undefined | — | Source Address Mode 1 and 0 |
| 14 | SM0 | Undefined | — | These bits specify a DTSAR operation after a data transfer. 0x: DTSAR is fixed 10: DTSAR is incremented after a transfer (by +1 when Sz 1 and 0 = 00; by +2 when Sz 1 and 0 = 01; by +4 when Sz 1 and 0 = 10) 11: DTSAR is decremented after a transfer (by -1 when Sz 1 and 0 = 00; by -2 when Sz 1 and 0 = 01; by -4 when Sz 1 and 0 = 10) |
| 13 | DM1 | Undefined | — | Destination Address Mode 1 and 0 |
| 12 | DM0 | Undefined | — | These bits specify a DTDAR operation after a data transfer. 0x: DTDAR is fixed 10: DTDAR is incremented after a transfer (by +1 when Sz 1 and 0 = 00; by +2 when Sz 1 and 0 = 01; by +4 when Sz 1 and 0 = 10) 11: DTDAR is decremented after a transfer (by -1 when Sz 1 and 0 = 00; by -2 when Sz 1 and 0 = 01; by -4 when Sz 1 and 0 = 10) |
| 11 | MD1 | Undefined | — | DTC Mode 1 and 0 |
| 10 | MD0 | Undefined | — | These bits specify the DTC transfer mode. 00: Normal mode 01: Repeat mode 10: Block transfer mode 11: Setting prohibited |
| 9 | Sz1 | Undefined | — | DTC Data Transfer Size 1 and 0 |
| 8 | Sz0 | Undefined | — | Specify the size of data to be transferred. 00: Byte-size transfer 01: Word-size transfer 10: longword-size transfer 11: Setting prohibited |

| Bit | Bit Name | Initial Value | R/W | Description |
|--------|----------|---------------|-----|--|
| 7 | DTS | Undefined | — | <p>DTC Transfer Mode Select</p> <p>Specifies whether the source or the destination is set to be a repeat area or block area, in repeat mode or block transfer mode.</p> <p>0: Destination is repeat area or block area 1: Source is repeat area or block area</p> |
| 6 | CHNE | Undefined | — | <p>DTC Chain Transfer Enable</p> <p>When this bit is set to 1, a chain transfer will be performed.</p> <p>0: Chain transfer is canceled 1: Chain transfer is set</p> <p>In data transfer with CHNE set to 1, determination of the end of the specified number of transfers, clearing of the activation source flag, and clearing of DTER is not performed.</p> |
| 5 | DISEL | Undefined | — | <p>DTC Interrupt Select</p> <p>When this bit is set to 1, a CPU interrupt request is generated every time a data transfer ends. When this bit is set to 0, a CPU interrupt request is generated at the time when the specified number of data transfer ends.</p> |
| 4 | NMIM | Undefined | — | <p>DTC NMI Mode</p> <p>This bit designates whether to terminate transfers when an NMI is input during DTC transfers.</p> <p>0: Terminate DTC transfer upon an NMI 1: Continue DTC transfer until end of transfer being executed</p> |
| 3 to 0 | — | Undefined | — | <p>Reserved</p> <p>These bits have no effect on DTC operation. The write value should always be 0.</p> |

[Legend]

x: Don't care

8.2.2 DTC Source Address Register (DTSAR)

The DTC source address register (DTSAR) is a 32-bit register that specifies the DTC transfer source address. For the word size transfer, specify an even source address. For the longword size transfer, specify a multiple-of-four address.

The initial value of DTSAR is undefined.

8.2.3 DTC Destination Address Register (DTDAR)

The DTC destination address register (DTDAR) is a 32-bit register that specifies the DTC transfer destination address. For the word size transfer, specify an even source address. For the longword size transfer, specify a multiple-of-four address.

The initial value of DTDAR is undefined.

8.2.4 DTC Initial Address Register (DTIAR)

The DTC initial address register (DTIAR) is a 32-bit register that specifies the initial transfer source/transfer destination address in repeat mode. In repeat mode, when the DTS bit is set to 1, specify the initial transfer source address in the repeat area, and when the DTS bit is cleared to 0, specify the initial transfer destination address in the repeat area.

The initial value of DTIAR is undefined.

8.2.5 DTC Transfer Count Register A (DTCRA)

DTCRA is a 16-bit register that designates the number of times data is to be transferred by the DTC.

In normal mode, the DTCRA functions as a 16-bit transfer counter (1 to 65536). It is decremented by 1 every time data is transferred, and transfer ends when the count reaches H'0000. The number of transfers is 1 when the set value is H'0001, 65535 when it is H'FFFF, and 65536 when it is H'0000.

In repeat mode, upper 8-bit DTCRAH maintains the transfer count value and lower 8-bit DTCRAL functions as an 8-bit transfer counter. The number of transfers is 1 when the set value is DTCRAH = DTCRAL = H'01, 255 when they are H'FF, and 256 when it is H'00.

In block transfer mode, the DTCRA functions as a 16-bit transfer counter. The number of transfers is 1 when the set value is H'0001, 65535 when it is H'FFFF, and 65536 when it is H'0000.

The initial value of DTCRA is undefined.

8.2.6 DTC Transfer Count Register B (DTCRB)

The DTCRB is a 16-bit register that designates the block length in block transfer mode. The block length is 1 when the set value is H'0001, 65535 when it is H'FFFF, and 65536 when it is H'0000.

The initial value of DTCRB is undefined.

8.2.7 DTC Enable Registers (DTER)

DTER which is comprised of six registers, DTEA to DTEE, DTEG, is a register that specifies DTC activation interrupt sources. The correspondence between interrupt sources and DTE bits is shown in table 8.1.

| Bit | Bit Name | Initial Value | R/W | Description |
|-----|----------|---------------|-----|--|
| 7 | DTE*7 | 0 | R/W | DTC Activation Enable |
| 6 | DTE*6 | 0 | R/W | Setting this bit to 1 specifies the corresponding interrupt source to a DTC activation source. |
| 5 | DTE*5 | 0 | R/W | [Clearing conditions] |
| 4 | DTE*4 | 0 | R/W | |
| 3 | DTE*3 | 0 | R/W | <ul style="list-style-type: none"> When the DISEL bit is 1 and the data transfer has ended |
| 2 | DTE*2 | 0 | R/W | <ul style="list-style-type: none"> When the specified number of transfers have ended |
| 1 | DTE*1 | 0 | R/W | <ul style="list-style-type: none"> 0 is written to the bit to be cleared after 1 has been read from the bit |
| 0 | DTE*0 | 0 | R/W | <ul style="list-style-type: none"> 0 is written to the bit to be cleared after 1 has been read from the bit |

These bits are not cleared when the DISEL bit is 0 and the specified number of transfers have not ended.

[Setting condition]

1 is written to the bit to be set after a 0 has been read from the bit

Note: * The last character of the DTC enable register's name comes here.

Example: DTEB3 in DTEB, etc.

8.2.8 DTC Control/Status Register (DTCSR)

DTCSR is a 16-bit readable/writable register that is used to disable/enable DTC activation by software and to set the DTC vector addresses for software activation. It also indicates the DTC transfer status.

| Bit | Bit Name | Initial Value | R/W | Description |
|----------|----------|---------------|---------------------|--|
| 15 to 11 | — | All 0 | R | Reserved These bits have no effect on DTC operation. The write value should always be 0. |
| 10 | NMIF | 0 | R/(W)* ¹ | NMI Flag Bit This bit indicates that an NMI interrupt has occurred. 0: No NMI interrupts [Clearing condition] <ul style="list-style-type: none"> Write 0 after reading the NMIF bit 1: NMI interrupt has been generated When the NMIF bit is set, DTC transfers are not allowed even if the DTER bit is set to 1. If, however, a transfer has already started with the NMIM bit of the DTMR set to 1, execution will continue until that transfer ends. |
| 9 | AE | 0 | R/(W)* ¹ | Address Error Flag This bit indicates that an address error by the DTC has occurred. 0: No address error by the DTC [Clearing condition] <ul style="list-style-type: none"> Write 0 after reading the AE bit 1: An address error by the DTC occurred When the AE bit is set, DTC transfers are not allowed even if the DTER bit is set to 1. |
| 8 | SWDTE | 0 | R/W* ² | DTC Software Activation Enable Setting this bit to 1 activates DTC. 0: DTC activation by software disabled 1: DTC activation by software enabled |

| Bit | Bit Name | Initial Value | R/W | Description |
|-----|----------|---------------|-----|--|
| 7 | DTVEC7 | 0 | R/W | DTC Software Activation Vectors 7 to 0 |
| 6 | DTVEC6 | 0 | R/W | These bits specify the lower eight bits of the vector addresses for DTC activation by software. |
| 5 | DTVEC5 | 0 | R/W | |
| 4 | DTVEC4 | 0 | R/W | A vector address is calculated as H'0400 + DTVEC (7:0). Always specify 0 for DTVEC0. For example, when DTVEC7 to DTVEC0 = H'10, the vector address is H'0410. When the bit SWDTE is 0, these bits can be written to. |
| 3 | DTVEC3 | 0 | R/W | |
| 2 | DTVEC2 | 0 | R/W | |
| 1 | DTVEC1 | 0 | R/W | |
| 0 | DTVEC0 | 0 | R/W | |

- Notes:
1. For the NMIF and AE bits, only a 0 write after a 1 read is possible.
 2. For the SWDTE bit, a 1 write is always possible, but a 0 write is possible only after a 1 is read.

8.2.9 DTC Information Base Register (DTBR)

The DTBR is a 16-bit readable/writable register that specifies the upper 16 bits of the memory address containing DTC transfer information. Always access the DTBR in word or longword units. If it is accessed in byte units the register contents will become undefined at the time of a write, and undefined values will be read out upon reads.

The initial value of DTBR is undefined.

8.3 Operation

8.3.1 Activation Sources

The DTC operates when activated by an interrupt or by a write to DTCSR by software. An interrupt request can be directed to the CPU or DTC, as designated by the corresponding DTER bit. At the end of a data transfer (or the last consecutive transfer in the case of chain transfer), the activation source interrupt flag or corresponding DTER bit is cleared. The activation source flag, in the case of RXI_2, for example, is the RDRF flag of SCI2.

When a DTC is activated by an interrupt, existing CPU mask level and interrupt controller priorities have no effect. If there is more than one activation source at the same time, the DTC operates in accordance with the default priorities.

Figure 8.2 shows a block diagram of activation source control. For details see section 6, Interrupt Controller (INTC).

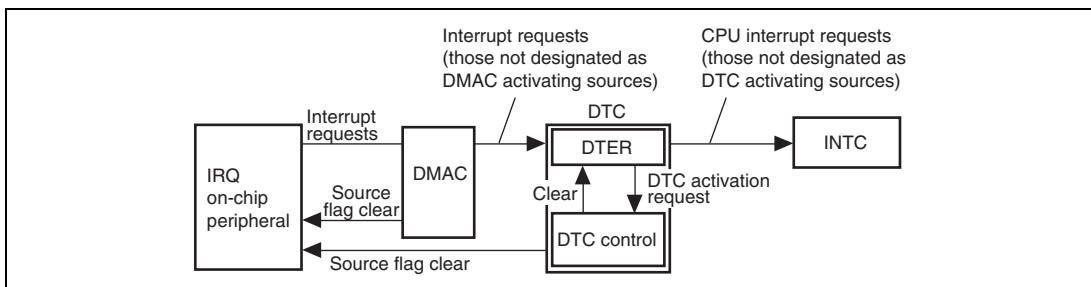

Figure 8.2 Activating Source Control Block Diagram

8.3.2 Location of Register Information and DTC Vector Table

Figure 8.3 shows the allocation of register information in memory space. The register information start addresses are designated by DTBR for the upper 16 bits, and the DTC vector table for the lower 16 bits.

The allocation in order from the register information start address in normal mode is DTMR, DTCRA, 4 bytes empty (no effect on DTC operation), DTSAR, then DTDAR. In repeat mode it is DTMR, DTCRA, DTIAR, DTSAR, and DTDAR. In block transfer mode, it is DTMR, DTCRA, 2 bytes empty (no effect on DTC operation), DTCRB, DTSAR, then DTDAR.

Fundamentally, certain RAM areas are designated for addresses storing register information.

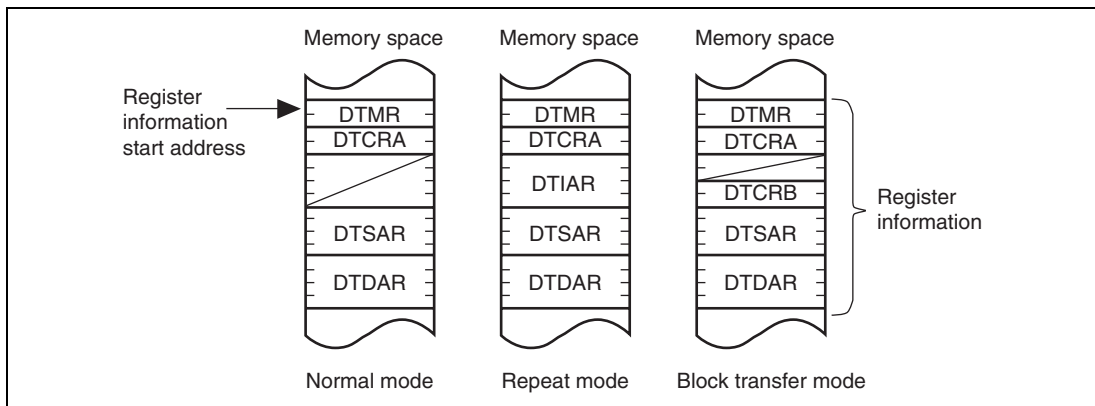

Figure 8.3 DTC Register Information Allocation in Memory Space

Figure 8.4 shows the correspondence between DTC vector addresses and register information allocation. For each DTC activating source there are 2 bytes in the DTC vector table, which contain the register information start address.

Table 8.1 shows the correspondence between activating sources and vector addresses. When activating with software, the vector address is calculated as $H'0400 + DTVEC[7:0]$.

Through DTC activation, a register information start address is read from the vector table, then register information placed in memory space is read from that register information start address. Always designate register information start addresses in multiples of four.

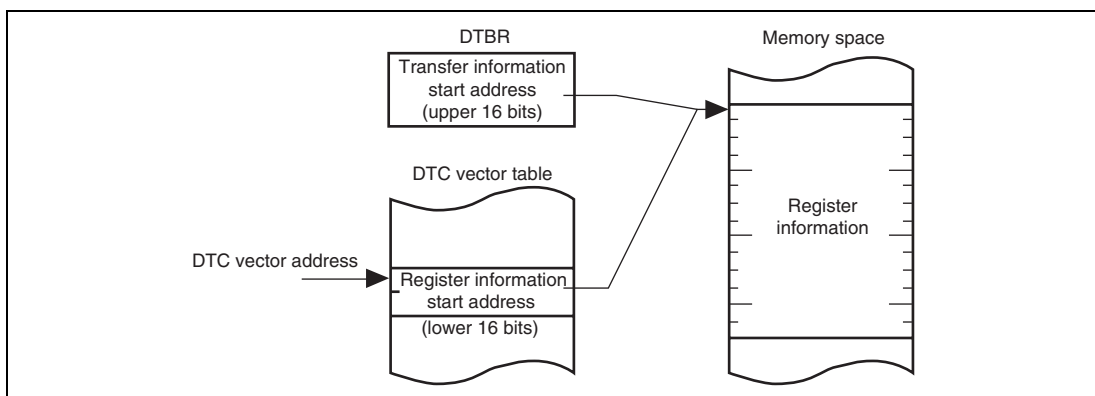



Figure 8.4 Correspondence between DTC Vector Address and Transfer Information

Table 8.1 Interrupt Sources, DTC Vector Addresses, and Corresponding DTEs

| Activating Source Generator | Activating Source | DTC Vector Address | DTE Bit | Transfer Source | Transfer Destination | Priority |
|-----------------------------|-------------------|--------------------|---------|-----------------|----------------------|-----------|
| MTU (CH4) | TGIA_4 | H'00000400 | DTEA7 | Arbitrary* | Arbitrary* | High ↑ |
| | TGIB_4 | H'00000402 | DTEA6 | Arbitrary* | Arbitrary* | |
| | TGIC_4 | H'00000404 | DTEA5 | Arbitrary* | Arbitrary* | |
| | TGID_4 | H'00000406 | DTEA4 | Arbitrary* | Arbitrary* | |
| | TCIV_4 | H'00000408 | DTEA3 | Arbitrary* | Arbitrary* | |
| MTU (CH3) | TGIA_3 | H'0000040A | DTEA2 | Arbitrary* | Arbitrary* | ↓ Low |
| | TGIB_3 | H'0000040C | DTEA1 | Arbitrary* | Arbitrary* | |
| | TGIC_3 | H'0000040E | DTEA0 | Arbitrary* | Arbitrary* | |
| | TGID_3 | H'00000410 | DTEB7 | Arbitrary* | Arbitrary* | |
| MTU (CH2) | TGIA_2 | H'00000412 | DTEB6 | Arbitrary* | Arbitrary* | |
| | TGIB_2 | H'00000414 | DTEB5 | Arbitrary* | Arbitrary* | |
| MTU (CH1) | TGIA_1 | H'00000416 | DTEB4 | Arbitrary* | Arbitrary* | |
| | TGIB_1 | H'00000418 | DTEB3 | Arbitrary* | Arbitrary* | |
| MTU (CH0) | TGIA_0 | H'0000041A | DTEB2 | Arbitrary* | Arbitrary* | |
| | TGIB_0 | H'0000041C | DTEB1 | Arbitrary* | Arbitrary* | |
| | TGIC_0 | H'0000041E | DTEB0 | Arbitrary* | Arbitrary* | |
| | TGID_0 | H'00000420 | DTEC7 | Arbitrary* | Arbitrary* | |
| A/D converter (CH0) | ADI0 | H'00000422 | DTEC6 | ADDR0 | Arbitrary* | |
| External pin | IRQ0 | H'00000424 | DTEC5 | Arbitrary* | Arbitrary* | |
| | IRQ1 | H'00000426 | DTEC4 | Arbitrary* | Arbitrary* | |
| | IRQ2 | H'00000428 | DTEC3 | Arbitrary* | Arbitrary* | |
| | IRQ3 | H'0000042A | DTEC2 | Arbitrary* | Arbitrary* | |
| | IRQ4 | H'0000042C | DTEC1 | Arbitrary* | Arbitrary* | |
| | IRQ5 | H'0000042E | DTEC0 | Arbitrary* | Arbitrary* | |
| | IRQ6 | H'00000430 | DTED7 | Arbitrary* | Arbitrary* | |
| | IRQ7 | H'00000432 | DTED6 | Arbitrary* | Arbitrary* | |
| CMT (CH0) | CMI0 | H'00000434 | DTED5 | Arbitrary* | Arbitrary* | |
| CMT (CH1) | CMI1 | H'00000436 | DTED4 | Arbitrary* | Arbitrary* | |

| Activating Source Generator | Activating Source | DTC Vector Address | DTE Bit | Transfer Source | Transfer Destination | Priority |
|-----------------------------|-------------------|--------------------------|---------|-----------------------|----------------------|---|
| SCI0 | RXI_0 | H'00000438 | DTED3 | RDR_0 | Arbitrary* | High  |
| | TXI_0 | H'0000043A | DTED2 | Arbitrary* | TDR_0 | |
| SCI1 | RXI_1 | H'0000043C | DTED1 | RDR_1 | Arbitrary* | |
| | TXI_1 | H'0000043E | DTED0 | Arbitrary* | TDR_1 | |
| Reserved | — | H'00000440 to H'00000443 | — | — | — | |
| A/D converter (CH1) | ADI1 | H'00000444 | DTEE5 | ADDR1 | Arbitrary* | |
| Reserved | — | H'00000446 | — | — | — | |
| SCI2 | RXI_2 | H'00000448 | DTEE3 | RDR_2 | Arbitrary* | |
| | TXI_2 | H'0000044A | DTEE2 | Arbitrary* | TDR_2 | |
| SCI3 | RXI_3 | H'0000044C | DTEE1 | RDR_3 | Arbitrary* | |
| | TXI_3 | H'0000044E | DTEE0 | Arbitrary* | TDR_3 | |
| Reserved | — | H'00000450 to H'0000045F | — | — | — | |
| IIC | ICI | H'00000460 | DTEG7 | ICDR (receive) | Arbitrary* (receive) | |
| | | | | Arbitrary* (transmit) | ICDR (transmit) | |
| Reserved | — | H'00000462 to H'0000049F | — | — | — | |
| Software | Write to DTCSR | H'0400+ DTVEC[7:0] | — | Arbitrary* | Arbitrary* | Low |

Note: * External memory, memory-mapped external devices, on-chip memory, on-chip peripheral modules (excluding DMAC and DTC)

8.3.3 DTC Operation

Register information is stored in an on-chip RAM. When activated, the DTC reads register information in an on-chip RAM and transfers data. After the data transfer, it writes updated register information back to the RAM.

Pre-storage of register information in the RAM makes it possible to transfer data over any required number of channels. The transfer mode can be specified as normal, repeat, and block transfer mode. Setting the CHNE bit to 1 makes it possible to perform a number of transfers with a single activation source (chain transfer).

The 32-bit DTSAR designates the DTC transfer source address and the 32-bit DTDAR designates the transfer destination address. After each transfer, DTSAR and DTDAR are independently incremented, decremented, or left fixed depending on its register information.

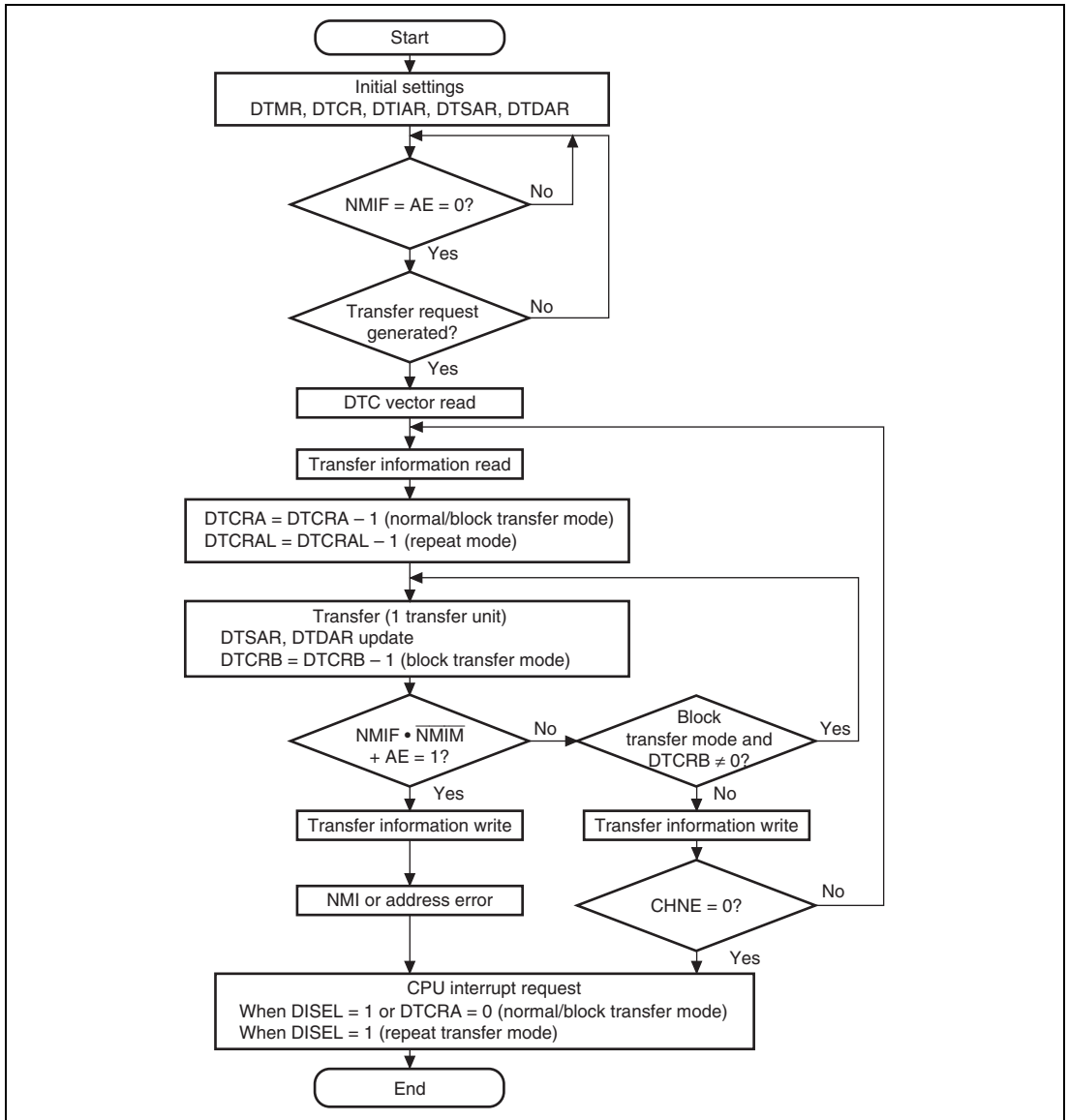

Figure 8.5 DTC Operation Flowchart

Normal Mode: Performs the transfer of one byte, one word, or one longword for each activation. The total transfer count is 1 to 65536. Once the specified number of transfers have ended, a CPU interrupt can be requested. Table 8.2 lists the register functions in normal mode. Figure 8.6 shows a memory map in normal mode.

Table 8.2 Normal Mode Register Functions

| Register | Function | Values Written Back upon Transfer Information Write | |
|----------|------------------------------|---|---------------------------|
| | | When DTCRA is other than 1 | When DTCRA is 1 |
| DTMR | Operation mode control | DTMR | DTMR |
| DTCRA | Transfer count | DTCRA – 1 | DTCRA – 1 (= H'0000) |
| DTSAR | Transfer source address | Increment/decrement/fixed | Increment/decrement/fixed |
| DTDAR | Transfer destination address | Increment/decrement/fixed | Increment/decrement/fixed |

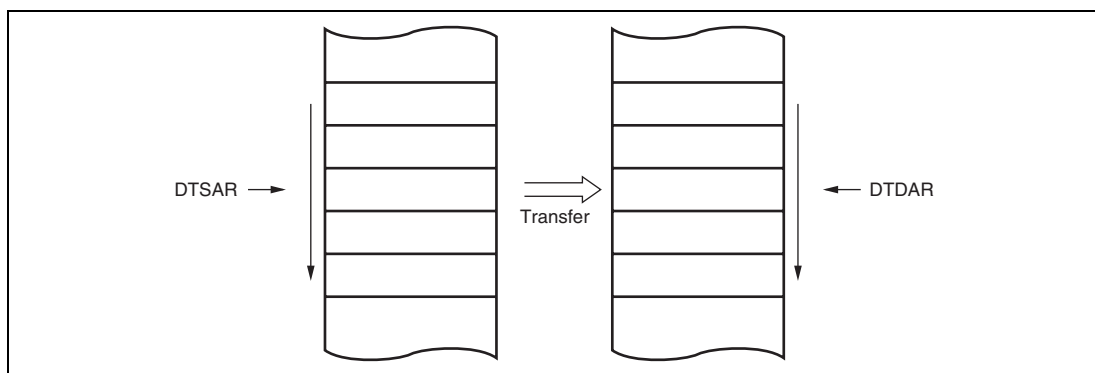

Figure 8.6 Memory Mapping in Normal Mode

Repeat Mode: Performs the transfer of one byte, one word, or one longword for each activation. Either the transfer source or transfer destination is designated as the repeat area. Table 8.3 lists the register functions in repeat mode. From 1 to 256 transfers can be specified. Once the specified number of transfers have ended, the initial state of the transfer counter and the address register specified as the repeat area is restored, and transfer is repeated. In repeat mode the transfer counter value does not reach H'00, and therefore CPU interrupts cannot be requested when DISEL = 0. Figure 8.7 shows a memory map in repeat mode.

Table 8.3 Repeat Mode Register Functions

| Register | Function | Values Written Back upon Transfer Information Write | |
|----------|------------------------------|---|--|
| | | When DTCRA is other than 1 | When DTCRA is 1 |
| DTMR | Operation mode control | DTMR | DTMR |
| DTCRAH | Transfer count save | DTCRAH | DTCRAH |
| DTCRAL | Transfer count | DTCRAL - 1 | DTCRAH |
| DTIAR | Initial address | (Not written back) | (Not written back) |
| DTSAR | Transfer source address | Increment/decrement/fixed | (DTS = 0) Increment/decrement/fixed (DTS = 1) DTIAR |
| DTDAR | Transfer destination address | Increment/decrement/fixed | (DTS = 0) DTIAR (DTS = 1) Increment/decrement/fixed |

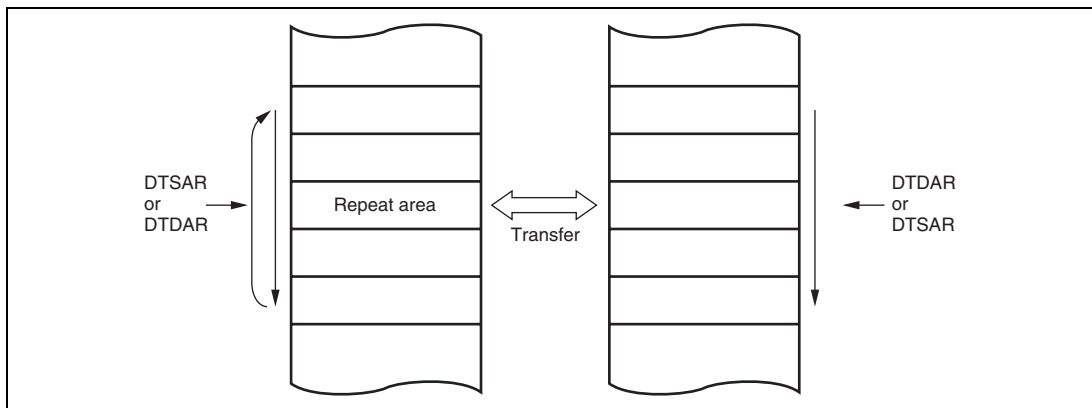

Figure 8.7 Memory Mapping in Repeat Mode

Block Transfer Mode: Performs the transfer of one block for each one activation. Either the transfer source or transfer destination is designated as the block area.

The block length is specified between 1 and 65536. When the transfer of one block ends, the initial state of the block size counter and the address register specified as the block area is restored. The other address register is then incremented, decremented, or left fixed.

From 1 to 65,536 transfers can be specified. Once the specified number of transfers have ended, a CPU interrupt is requested. Table 8.4 lists the register functions in block transfer mode. Figure 8.8 shows a memory map in block transfer mode.

Table 8.4 Block Transfer Mode Register Functions

| Register | Function | Values Written Back upon Transfer Information Write |
|----------|------------------------------|--|
| DTMR | Operation mode control | DTMR |
| DTCRA | Transfer count | DTCRA – 1 |
| DTCRB | Block length | (Not written back) |
| DTSAR | Transfer source address | (DTS = 0) Increment/ decrement/ fixed (DTS = 1) DTSAR initial value |
| DTDAR | Transfer destination address | (DTS = 0) DTDAR initial value (DTS = 1) Increment/ decrement/ fixed |

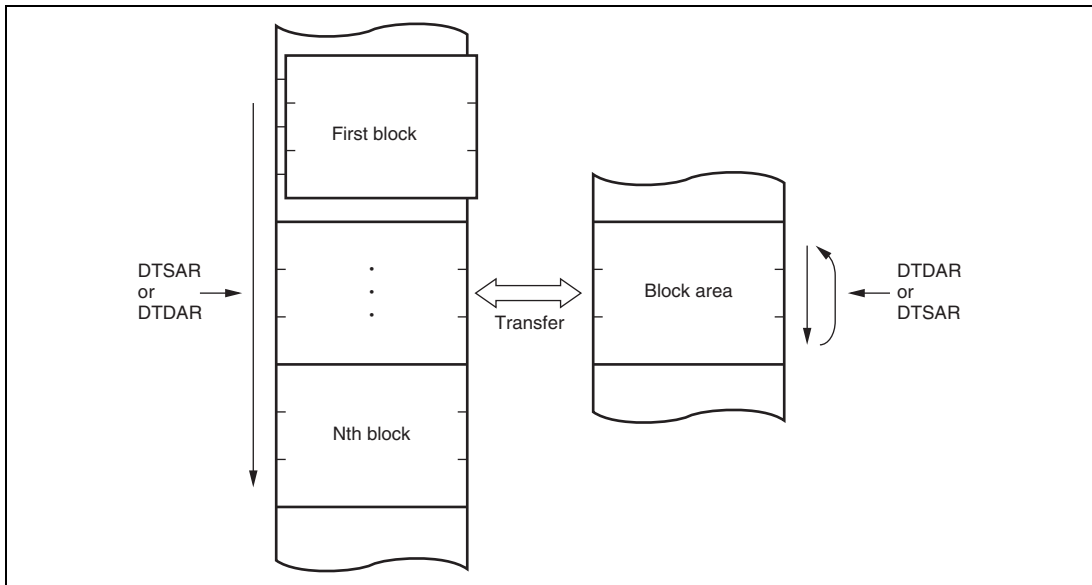

Figure 8.8 Memory Mapping in Block Transfer Mode

Chain Transfer: Setting the CHNE bit to 1 enables a number of data transfers to be performed consecutively in a single activation source. DTSAR, DTDAR, DTMR, DTCRA, and DTCRB can be set independently.

Figure 8.9 shows the chain transfer.

When activated, the DTC reads the register information start address stored at the vector address, and then reads the first register information at that start address. After the data transfer, the CHNE bit will be tested. When it has been set to 1, DTC reads next register information located in a consecutive area and performs the data transfer. These sequences are repeated until the CHNE bit is cleared to 0.

In the case of transfer with CHNE set to 1, an interrupt request to the CPU is not generated at the end of the specified number of transfers or by setting of the DISEL bit to 1, and the interrupt source flag for the activation source is not affected.

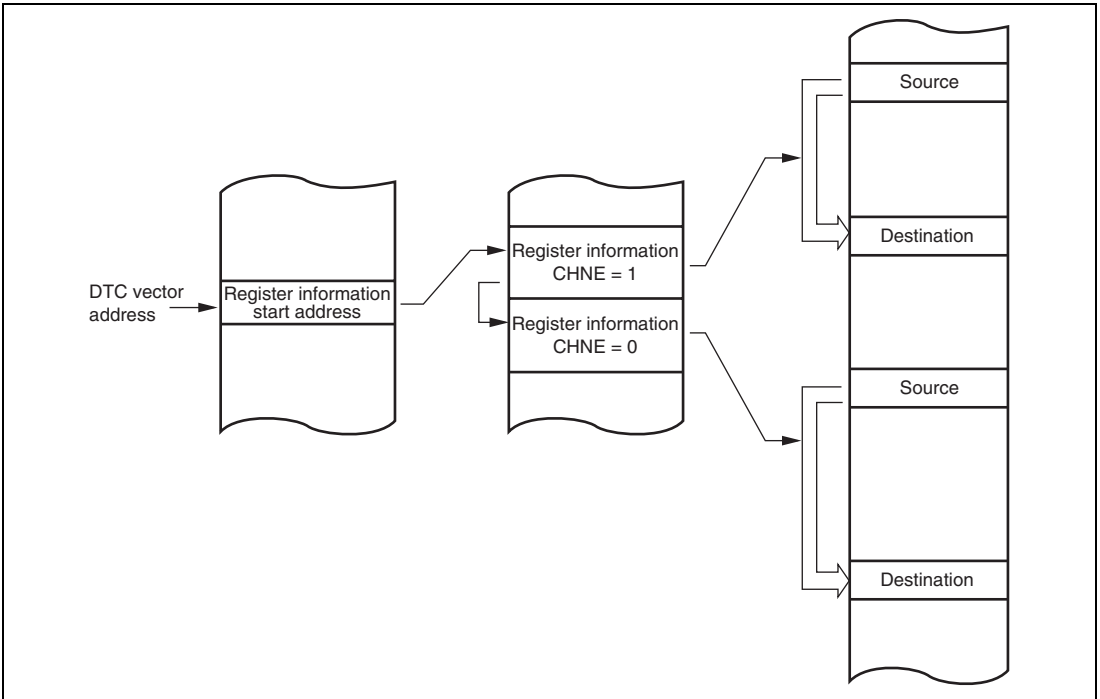
**Figure 8.9 Chain Transfer**

8.3.4 Interrupt Source

An interrupt request is issued to the CPU when the DTC finishes the specified number of data transfers, or a data transfer for which the DISEL bit was set to 1. In the case of interrupt activation, the interrupt set as the activation source is generated. These interrupts to the CPU are subject to CPU mask level and interrupt controller priority level control.

In the case of activation by software, a software activated data transfer end interrupt (SWDTEND) is generated.

When the DISEL bit is 1 and one data transfer has ended, or the specified number of transfers have ended, after data transfer ends, the SWDTE bit is held at 1 and an SWDTEND interrupt is generated. The interrupt handling routine should clear the SWDTE bit to 0.

When the DTC is activated by software, an SWDTEND interrupt is not generated during a data transfer wait or during data transfer even if the SWDTE bit is set to 1.

Note: When the DTCR contains a value equal to or greater than 2, the SWDTE bit is automatically cleared to 0. When the DTCR is set to 1, the SWDTE bit is again set to 1.

8.3.5 Operation Timing

When register information is located in on-chip RAM, each mode requires 4 cycles for transfer information reads, and 3 cycles for writes.

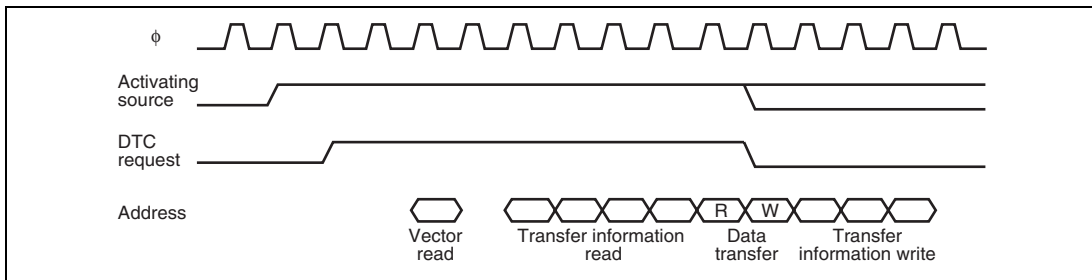

Figure 8.10 DTC Operation Timing Example (Normal Mode)

8.3.6 DTC Execution State Counts

Table 8.5 shows the execution state for one DTC data transfer. Furthermore, table 8.6 shows the state counts needed for execution state.

Table 8.5 Execution State of DTC

| Mode | Vector Read I | Register Information Read/Write J | Data Read K | Data Write L | Internal Operation M |
|----------------|---------------|-----------------------------------|-------------|--------------|----------------------|
| Normal | 1 | 7 | 1 | 1 | 1 |
| Repeat | 1 | 7 | 1 | 1 | 1 |
| Block transfer | 1 | 7 | N | N | 1 |

N: block size (default set values of DTCRB)

Table 8.6 State Counts Needed for Execution State

| Access Objective | | | On-chip RAM | On-chip ROM | Internal I/O Register | | External Device | | |
|--------------------|---------------------------------|----------------|-------------|-------------|-----------------------|-----------------|-----------------|----|----|
| Bus width | | | 32 | 32 | 8 or 16 | | 8 | 16 | 32 |
| Access state | | | 1 | 1 | 2* ¹ | 3* ² | 2 | 2 | 2 |
| Execution state | Vector read | S _I | — | 1 | — | — | 4 | 2 | 2 |
| | Register information read/write | S _J | 1 | 1 | — | — | 8 | 4 | 2 |
| | Byte data read | S _K | 1 | 1 | 2 | 3 | 2 | 2 | 2 |
| | Word data read | S _K | 1 | 1 | 2 | 3 | 4 | 2 | 2 |
| | Long word data read | S _K | 1 | 1 | 4 | 6 | 8 | 4 | 2 |
| | Byte data write | S _L | 1 | 1 | 2 | 3 | 2 | 2 | 2 |
| | Word data write | S _L | 1 | 1 | 2 | 3 | 4 | 2 | 2 |
| | Longword data write | S _L | 1 | 1 | 4 | 6 | 8 | 4 | 2 |
| Internal operation | | S _M | | | 1 | | | | |

Notes: 1. Two state access module: port, INT, CMT, SCI, etc.

2. Three state access module: WDT, UBC, etc.

The execution state count is calculated using the following formula. Σ indicates the number of transfers by one activating source (count + 1 when CHNE bit is set to 1).

$$\text{Execution state count} = I \cdot S_I + \Sigma (J \cdot S_J + K \cdot S_K + L \cdot S_L) + M \cdot S_M$$

8.4 Procedures for Using DTC

8.4.1 Activation by Interrupt

The procedure for using the DTC with interrupt activation is as follows:

1. Set the DTMR, DTCRA, DTSAR, DTDAR, DTCRB, and DTIAR register information in memory space.
2. Specify the register information start address with DTBR and the DTC vector table.
3. Set the corresponding DTER bit to 1.
4. The DTC is activated when an interrupt source occurs.
5. When interrupt requests are not made to the CPU, the interrupt source is cleared, but the DTER is not. When interrupts are requested, the interrupt source is not cleared, but the DTER is.
6. Interrupt sources are cleared within the CPU interrupt routine. When doing continuous DTC data transfers, set the DTER to 1 after reading DTER = 0.

8.4.2 Activation by Software

The procedure for using the DTC with software activation is as follows:

1. Set the DTMR, DTCRA, DTSAR, DTDAR, DTCRB, and DTIAR register information in memory space.
2. Set the start address of the register information in the DTBR register and the DTC vector address.
3. Check that the SWDTE bit is 0.
4. Write 1 to SWDTE bit and the vector number to DTVEC.
5. Check the vector number written to DTVEC.
6. After the end of one data transfer, if the DISEL bit is 0 and a CPU interrupt is not requested, the SWDTE bit is cleared to 0. If the DTC is to continue transferring data, set the SWDTE bit to 1. When the DISEL bit is 1, or after the specified number of data transfers have ended, the SWDTE bit is held at 1 and a CPU interrupt is requested.
7. The SWDTE bit is cleared to 0 within the CPU interrupt routine. For continuous DTC data transfer, set the SWDTE bit to 1 after confirming that its current value is 0. Then write the vector number to DTVEC for continuous DTC transfer.

8.4.3 DTC Use Example

The following is a DTC use example of a 128-byte data reception by the SCI:

1. The settings are: DTMR source address fixed ($SM1 = SM0 = 0$), destination address incremented ($DM1 = 1, DM0 = 0$), normal mode ($MD1 = MD0 = 0$), byte size ($SZ1 = SZ0 = 0$), one transfer per activating source ($CHNE = 0$), and a CPU interrupt request after the designated number of data transfers ($DISEL = 0$). DTS bit can be set to any value. 128 (H'0080) is set in DTCRA, the RDR address of the SCI is set in DTSAR, and the start address of the RAM storing the receive data is set in DTDAR. DTCRB can be set to any value.
2. Set the register information start address with DTBR and the DTC vector table.
3. Set the corresponding DTER bit to 1.
4. Set the SCI to the appropriate receive mode. Set the RIE bit in SCR to 1 to enable the reception complete (RXI) interrupt. Since the generation of a receive error during the SCI reception operation will disable subsequent reception, the CPU should be enabled to accept receive error interrupts.
5. Each time reception of one byte of data ends on the SCI, the RDRF flag in SSR is set to 1, an RXI interrupt is generated, and the DTC is activated. The receive data is transferred from RDR to RAM by the DTC. DTDAR is incremented and DTCRA is decremented. The RDRF flag is automatically cleared to 0.
6. When DTCRA is 0 after the 128 data transfers have ended, the RDRF flag is held at 1, the corresponding bit in DTER is cleared to 0, and an RXI interrupt request is sent to the CPU. The interrupt handling routine should perform completion processing.

8.5 Usage Notes

8.5.1 Prohibition against DMAC/DTC Register Access by DTC

DMAC and DTC register access by the DMAC is prohibited.

8.5.2 Module Standby Mode Setting

DTC operation can be disabled or enabled using the module standby control register. The initial setting is for DTC operation to be halted. Register access is enabled by clearing module standby mode.

When the MSTP24 and MSTP25 bits in MSTCR1 are set to 1, the DTC clock is halted and the DTC enters module standby mode. The MSTP24 and MSTP25 bit cannot be set to 1 during activation of the DTC.

In addition, when the module standby mode is entered, clear all the DTER bits to 0.

For details, refer to section 24, Power-Down Modes.

8.5.3 On-Chip RAM

The DTMR, DTSAR, DTDAR, DTCRA, DTCRB and DTIAR registers are all located in on-chip RAM. When the DTC is used, the RAME bit in SYSCR must not be cleared to 0.

Section 9 Bus State Controller (BSC)

The bus state controller (BSC) divides up the address spaces and outputs control signals for various types of memory. This enables memories like SRAM and ROM to be connected directly to the chip without external circuitry.

9.1 Features

The BSC has the following features:

- Address space is divided into four spaces
 - A maximum linear 2 Mbytes for on-chip ROM enabled mode, and a maximum 4 Mbytes for on-chip ROM disabled mode, for address spaces CS0 and CS4
 - A maximum linear 4 Mbytes for address space CS1 to CS3 and CS5 to CS7
 - Bus width (8, 16, or 32 bits) can be selected for each space
 - Wait states can be inserted by software for each space
 - Wait state insertion with $\overline{\text{WAIT}}$ pin in external memory space access
 - Outputs control signals for each space according to the type of memory connected
- On-chip ROM and RAM interfaces
 - On-chip ROM and RAM access of 32 bits in 1 state

Figure 9.1 shows the BSC block diagram.

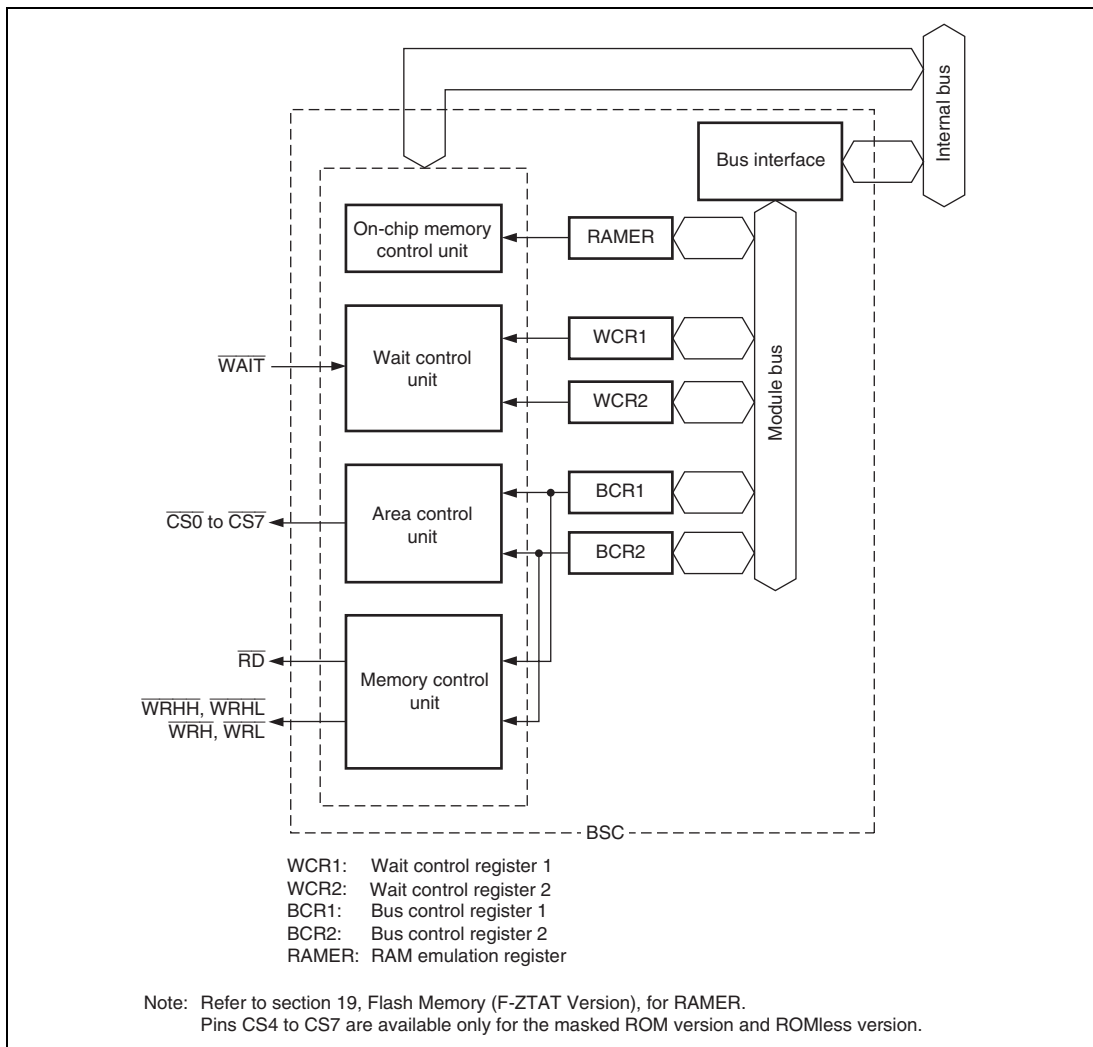

Figure 9.1 BSC Block Diagram

9.2 Input/Output Pins

Table 9.1 shows the bus state controller pin configuration.

Table 9.1 Pin Configuration

| Name | Abbr. | I/O | Description |
|-----------------|--|--------|--|
| Address bus | A21 to A0 | Output | Address output (Address bus A21 to A18 pins are disabled and I/O port function is enabled after power-on-reset.) |
| Data bus | D31 to D0 | I/O | 32-bit data bus |
| Chip select | $\overline{CS0}$ to $\overline{CS7}$ * | Output | Chip select signal indicating the area being accessed |
| Read | \overline{RD} | Output | Strobe that indicates the read cycle |
| Write | \overline{WRHH} | Output | Strobe that indicates a write cycle to the first byte (D31 to D24) |
| | \overline{WRHL} | Output | Strobe that indicates a write cycle to the second byte (D23 to D16) |
| | \overline{WRH} | Output | Strobe that indicates a write cycle to the third byte (D15 to D8) |
| | \overline{WRL} | Output | Strobe that indicates a write cycle to the fourth byte (D7 to D0) |
| Wait | \overline{WAIT} | Input | Wait state request signal |
| Bus request | \overline{BREQ} | Input | Bus request input |
| Bus acknowledge | \overline{BACK} | Output | Bus use enable output |

Note: * Pins $\overline{CS4}$ to $\overline{CS7}$ are available only for the masked ROM version and ROMless version.

9.3 Register Configuration

The BSC has five registers. For details on these register addresses and register states in each processing states, refer to section 25, List of Registers.

These registers are used to control wait states, bus width, and interfaces with memories like ROM and SRAM. All registers are 16 bits.

- Bus control register 1 (BCR1)
- Bus control register 2 (BCR2)
- Wait control register 1 (WCR1)
- Wait control register 2 (WCR2)
- RAM emulation register (RAMER)

9.4 Address Map

Figure 9.2 shows the address format used by this LSI.

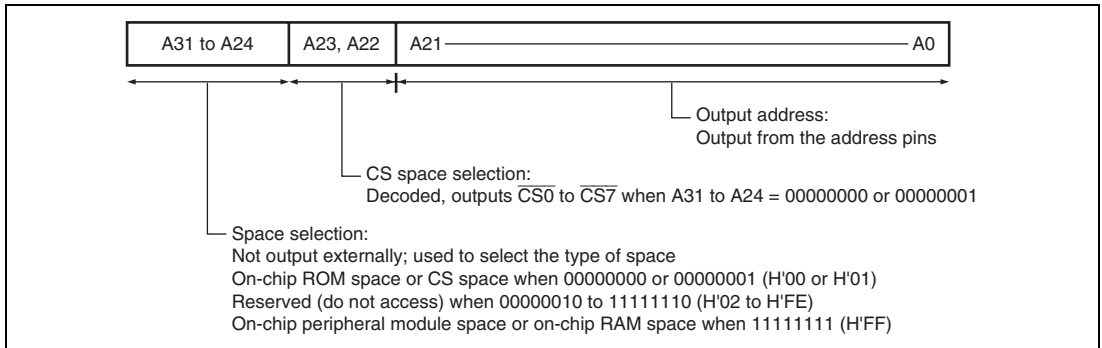

Figure 9.2 Address Format

This chip uses 32-bit addresses:

- Bits A31 to A24 are used to select the type of space and are not output externally.
- Bits A23 and A22 are decoded and output as chip select signals ($\overline{CS0}$ to $\overline{CS7}$) for the corresponding areas when bits A31 to A24 are 00000000 or 00000001.
- Bits A21 to A0 are output externally.

Table 9.2 shows the address map.

Table 9.2 Address Map

- On-chip ROM enabled mode

| Address | Space | Memory | Size | Bus Width |
|----------------------------|---------------------------|---------------------------|------------|----------------------------|
| H'00000000 to H'0003FFFF | On-chip ROM | On-chip ROM | 256 kbytes | 32 bits |
| H'00040000 to H'001FFFFFFF | Reserved | Reserved | | |
| H'00200000 to H'003FFFFFFF | CS0 space | External space | 2 Mbytes | 8/16/32 bits* ¹ |
| H'00400000 to H'007FFFFFFF | CS1 space | External space | 4 Mbytes | 8/16/32 bits* ¹ |
| H'00800000 to H'00BFFFFFFF | CS2 space | External space | 4 Mbytes | 8/16/32 bits* ¹ |
| H'00C00000 to H'00FFFFFFF | CS3 space | External space | 4 Mbytes | 8/16/32 bits* ¹ |
| H'01000000 to H'011FFFFFFF | Reserved | Reserved | | |
| H'01200000 to H'013FFFFFFF | CS4 space* ³ | External space | 2 Mbytes | 8/16/32 bits* ¹ |
| H'01400000 to H'017FFFFFFF | CS5 space* ³ | External space | 4 Mbytes | 8/16/32 bits* ¹ |
| H'01800000 to H'01BFFFFFFF | CS6 space* ³ | External space | 4 Mbytes | 8/16/32 bits* ¹ |
| H'01C00000 to H'01FFFFFFF | CS7 space* ³ | External space | 4 Mbytes | 8/16/32 bits* ¹ |
| H'02000000 to H'FFFF7FFF | Reserved | Reserved | | |
| H'FFFF8000 to H'FFFFBFFF | On-chip peripheral module | On-chip peripheral module | 16 kbytes | 8/16 bits |
| H'FFFFC000 to H'FFFFDFFF | Reserved | Reserved | | |
| H'FFFFE000 to H'FFFFFFF | On-chip RAM | On-chip RAM | 8 kbytes | 32 bits |

- On-chip ROM disabled mode

| Address | Space | Memory | Size | Bus Width |
|----------------------------|---------------------------|---------------------------|-----------|----------------------------|
| H'00000000 to H'003FFFFFFF | CS0 space | External space | 4 Mbytes | 8/16/32 bits* ² |
| H'00400000 to H'007FFFFFFF | CS1 space | External space | 4 Mbytes | 8/16/32 bits* ¹ |
| H'00800000 to H'00BFFFFFFF | CS2 space | External space | 4 Mbytes | 8/16/32 bits* ¹ |
| H'00C00000 to H'00FFFFFFF | CS3 space | External space | 4 Mbytes | 8/16/32 bits* ¹ |
| H'01000000 to H'013FFFFFFF | CS4 space* ³ | External space | 4 Mbytes | 8/16/32 bits* ² |
| H'01400000 to H'017FFFFFFF | CS5 space* ³ | External space | 4 Mbytes | 8/16/32 bits* ¹ |
| H'01800000 to H'01BFFFFFFF | CS6 space* ³ | External space | 4 Mbytes | 8/16/32 bits* ¹ |
| H'01C00000 to H'01FFFFFFF | CS7 space* ³ | External space | 4 Mbytes | 8/16/32 bits* ¹ |
| H'02000000 to H'FFFF7FFF | Reserved | Reserved | | |
| H'FFFF8000 to H'FFFFBFFF | On-chip peripheral module | On-chip peripheral module | 16 kbytes | 8/16 bits |
| H'FFFC000 to H'FFFDFFF | Reserved | Reserved | | |
| H'FFFE000 to H'FFFFFFF | On-chip RAM | On-chip RAM | 8 kbytes | 32 bits |

Notes: Do not access reserved spaces. Operation cannot be guaranteed if they are accessed. Spaces other than on-chip ROM, on-chip RAM, and on-chip peripheral modules cannot be used in single-chip mode.

- Selected by setting the on-chip register.
- Selected by the mode pin: 8 or 16 bits in SH7144 (112 pins)
16 or 32 bits in SH7145 (144 pins)
- Spaces CS4 to CS7 are available only for the masked ROM version and ROMless version. These spaces are reserved for the flash memory version and emulator.

9.5 Register Descriptions

9.5.1 Bus Control Register 1 (BCR1)

BCR1 is a 16-bit readable/writable register that enables access to the MTU control registers and specifies the bus size of each CS space. When using the SH7144, specify the bus size as word (16-bit) or smaller size.

Write bits 7 to 0 of BCR1 during the initialization stage after a power-on reset, and do not change the values thereafter. In on-chip ROM enabled mode, do not access any of each CS space until completion of register initialization. In on-chip ROM disabled mode, do not access CS spaces other than CS0 and CS4 until completion of register initialization.

| Bit | Bit Name | Initial Value | R/W | Description |
|---------|----------|---------------|-----|--|
| 15 | — | 0 | R | Reserved This bit is always read as 0. The write value should always be 0. |
| 14 | — | 1 | R | Reserved This bit is always read as 1. The write value should always be 1. |
| 13 | MTURWE | 1 | R/W | MTU read/write enable This bit enables MTU control register access. For details, refer to section 11, Multi-Function Timer Pulse Unit (MTU). 0: MTU control register access is disabled 1: MTU control register access is enabled |
| 12 to 8 | — | All 0 | R | Reserved These bits are always read as 0. The write value should always be 0. |
| 7 | A3LG | 0 | R/W | CS3 and CS7 space longword This bit specifies the CS3 and CS7 space bus size. This bit is valid only for the SH7145. This bit is reserved in SH7144. This bit is always read as 0 and should always be written with 0. 0: Depends on the value set with the A3SZ bit in this register. 1: Longword (32 bits) |

| Bit | Bit Name | Initial Value | R/W | Description |
|-----|----------|---------------|-----|--|
| 6 | A2LG | 0 | R/W | <p>CS2 and CS6 space longword</p> <p>This bit specifies the CS2 and CS6 space bus size. This bit is valid only for the SH7145.</p> <p>This bit is reserved in SH7144. This bit is always read as 0 and should always be written with 0.</p> <p>0: Depends on the value set with the A2SZ bit in this register.</p> <p>1: Longword (32 bits)</p> |
| 5 | A1LG | 0 | R/W | <p>CS1 and CS5 space longword</p> <p>This bit specifies the CS1 and CS5 space bus size. This bit is valid only for the SH7145.</p> <p>This bit is reserved in SH7144. This bit is always read as 0 and should always be written with 0.</p> <p>0: Depends on the value set with the A1SZ bit in this register.</p> <p>1: Longword (32 bits)</p> |
| 4 | A0LG | 0 | R/W | <p>CS0 and CS4 space longword</p> <p>This bit specifies the CS0 and CS4 space bus size. This bit is valid only for the SH7145.</p> <p>This bit is reserved in SH7144. This bit is always read as 0 and should always be written with 0.</p> <p>0: Depends on the value set with the A0SZ bit in this register.</p> <p>1: Longword (32 bits)</p> <p>Note: A0LG is valid only in on-chip ROM enabled mode. The CS0 and CS4 space bus size is specified with the mode pin in on-chip ROM disabled mode.</p> |
| 3 | A3SZ | 1 | R/W | <p>CS3 and CS7 space size</p> <p>This bit specifies the CS3 and CS7 space bus size in A3LG = 0.</p> <p>0: Byte (8 bits)</p> <p>1: Word (16 bits)</p> <p>Note: In A3LG = 1, this bit is ignored and the CS3 and CS7 space bus size is longword (32 bits).</p> |

| Bit | Bit Name | Initial Value | R/W | Description |
|-----|----------|---------------|-----|--|
| 2 | A2SZ | 1 | R/W | <p>CS2 and CS6 space size</p> <p>This bit specifies the CS2 and CS6 space bus size in A2LG = 0.</p> <p>0: Byte (8 bits)</p> <p>1: Word (16 bits)</p> <p>Note: In A2LG = 1, this bit is ignored and the CS2 and CS6 space bus size is longword (32 bits).</p> |
| 1 | A1SZ | 1 | R/W | <p>CS1 and CS5 space size</p> <p>This bit specifies the CS1 and CS5 space bus size in A1LG = 0.</p> <p>0: Byte (8 bits)</p> <p>1: Word (16 bits)</p> <p>Note: In A1LG = 1, this bit is ignored and the CS1 and CS5 space bus size is longword (32 bits).</p> |
| 0 | A0SZ | 1 | R/W | <p>CS0 and CS4 space size</p> <p>This bit specifies the CS0 and CS4 space bus size in A0LG = 0.</p> <p>0: Byte (8 bits)</p> <p>1: Word (16 bits)</p> <p>Note: This bit is valid only in on-chip ROM enabled mode. The CS0 and CS4 space bus size is specified with the mode pin in on-chip ROM disabled mode. Even in on-chip ROM enabled mode, this bit is ignored in A0LG = 1, and the CS0 and CS4 space bus size is longword (32 bits).</p> |

9.5.2 Bus Control Register 2 (BCR2)

BCR2 is a 16-bit readable/writable register that specifies the number of idle cycles and \overline{CS} signal assert extension of each CS space.

| Bit | Bit Name | Initial Value | R/W | Description |
|-----|----------|---------------|-----|---|
| 15 | IW31 | 1 | R/W | Idle cycles in CS3 and CS7 space cycles |
| 14 | IW30 | 1 | R/W | After read access to the CS3 and CS7 spaces, these bits insert idle cycles (1) when the write cycle to the CS3 space continues, (2) when the write cycle to the CS7 space continues, or (3) when continuous access is made to CS spaces except for the CS3 and CS7 spaces. 00: No idle cycle inserted after access to the CS3 and CS7 spaces 01: One idle cycle inserted after access to the CS3 and CS7 spaces 10: Two idle cycles inserted after access to the CS3 and CS7 spaces 11: Three idle cycles inserted after access to the CS3 and CS7 spaces |
| 13 | IW21 | 1 | R/W | Idle cycles in CS2 and CS6 space cycles |
| 12 | IW20 | 1 | R/W | After read access to the CS2 and CS6 spaces, these bits insert idle cycles (1) when the write cycle to the CS2 space continues, (2) when the write cycle to the CS6 space continues, or (3) when continuous access is made to CS spaces except for the CS2 and CS6 spaces. 00: No idle cycle inserted after access to the CS2 and CS6 spaces 01: One idle cycle inserted after access to the CS2 and CS6 spaces 10: Two idle cycles inserted after access to the CS2 and CS6 spaces 11: Three idle cycles inserted after access to the CS2 and CS6 spaces |

| Bit | Bit Name | Initial Value | R/W | Description |
|-----|----------|---------------|-----|---|
| 11 | IW11 | 1 | R/W | Idle cycles in CS1 and CS5 space cycles |
| 10 | IW10 | 1 | R/W | After read access to the CS1 and CS5 spaces, these bits insert idle cycles (1) when the write cycle to the CS1 space continues, (2) when the write cycle to the CS5 space continues, or (3) when continuous access is made to CS spaces except for the CS1 and CS5 spaces. 00: No idle cycle inserted after access to the CS1 and CS5 spaces 01: One idle cycle inserted after access to the CS1 and CS5 spaces 10: Two idle cycles inserted after access to the CS1 and CS5 spaces 11: Three idle cycles inserted after access to the CS1 and CS5 spaces |
| 9 | IW01 | 1 | R/W | Idle cycles in CS0 and CS4 space cycles |
| 8 | IW00 | 1 | R/W | After read access to the CS0 and CS4 spaces, these bits insert idle cycles (1) when the write cycle to the CS0 space continues, (2) when the write cycle to the CS4 space continues, or (3) when continuous access is made to CS spaces except for the CS0 and CS4 spaces. 00: No idle cycle inserted after access to the CS0 and CS4 spaces 01: One idle cycle inserted after access to the CS0 and CS4 spaces 10: Two idle cycles inserted after access to the CS0 and CS4 spaces 11: Three idle cycles inserted after access to the CS0 and CS4 spaces |

| Bit | Bit Name | Initial Value | R/W | Description |
|-----|----------|---------------|-----|--|
| 7 | CW3 | 1 | R/W | <p>Idle cycles at continuous access to CS3 and CS7 spaces</p> <p>This bit inserts an idle cycle and negates the $\overline{\text{CS3}}$ signal to make the bus cycle end obvious when accessing the CS3 space continuously. An idle cycle set by this bit is also inserted when access is made to the CS7 space after access to the CS3 space. In addition, an idle cycle set by this bit is inserted when continuous access is made to the CS7 space, and when access is made to the CS3 space after access to the CS7 space.</p> <p>0: No idle cycle inserted at continuous access to the CS3 and CS7 spaces.</p> <p>1: One idle cycle inserted at continuous access to the CS3 and CS7 spaces.</p> <p>When the write cycle follows the read cycle, the larger of the value specified with IW and that specified with CW is used as the idle cycles to be inserted.</p> |
| 6 | CW2 | 1 | R/W | <p>Idle cycles at continuous access to CS2 and CS6 spaces</p> <p>This bit inserts an idle cycle and negates the $\overline{\text{CS2}}$ signal to make the bus cycle end obvious when accessing the CS2 space continuously. An idle cycle set by this bit is also inserted when access is made to the CS6 space after access to the CS2 space. In addition, an idle cycle set by this bit is inserted when continuous access is made to the CS6 space, and when access is made to the CS2 space after access to the CS6 space.</p> <p>0: No idle cycle inserted at continuous access to the CS2 and CS6 spaces.</p> <p>1: One idle cycle inserted at continuous access to the CS2 and CS6 spaces.</p> <p>When the write cycle follows the read cycle, the larger of the value specified with IW and that specified with CW is used as the idle cycles to be inserted.</p> |

| Bit | Bit Name | Initial Value | R/W | Description |
|-----|----------|---------------|-----|---|
| 5 | CW1 | 1 | R/W | <p>Idle cycles at continuous access to CS1 and CS5 spaces</p> <p>This bit inserts an idle cycle and negates the $\overline{CS1}$ signal to make the bus cycle end obvious when accessing the CS1 space continuously. An idle cycle set by this bit is also inserted when access is made to the CS5 space after access to the CS1 space. In addition, an idle cycle set by this bit is inserted when continuous access is made to the CS5 space, and when access is made to the CS1 space after access to the CS5 space.</p> <p>0: No idle cycle inserted at continuous access to the CS1 and CS5 spaces.</p> <p>1: One idle cycle inserted at continuous access to the CS1 and CS5 spaces.</p> <p>When the write cycle follows the read cycle, the larger of the value specified with IW and that specified with CW is used as the idle cycles to be inserted.</p> |
| 4 | CW0 | 1 | R/W | <p>Idle cycles at continuous access to CS0 and CS4 spaces</p> <p>This bit inserts an idle cycle and negates the $\overline{CS0}$ signal to make the bus cycle end obvious when accessing the CS0 space continuously. An idle cycle set by this bit is also inserted when access is made to the CS4 space after access to the CS0 space. In addition, an idle cycle set by this bit is inserted when continuous access is made to the CS4 space, and when access is made to the CS0 space after access to the CS4 space.</p> <p>0: No idle cycle inserted at continuous access to the CS0 and CS4 spaces.</p> <p>1: One idle cycle inserted at continuous access to the CS0 and CS4 spaces.</p> <p>When the write cycle follows the read cycle, the larger of the value specified with IW and that specified with CW is used as the idle cycles to be inserted.</p> |
| 3 | SW3 | 1 | R/W | <p>\overline{CS} assert period extension for CS3 and CS7 spaces</p> <p>This bit inserts a cycle to prevent the assert period of \overline{RD} and \overline{WRx} from extending the assert period of $\overline{CS3}$ and $\overline{CS7}$.</p> <p>0: No cycle inserted for \overline{CS} assert period for CS3 and CS7 spaces.</p> <p>1: \overline{CS} assert extension for CS3 and CS7 spaces. (Each one cycle inserted before and after the bus cycle)</p> |

| Bit | Bit Name | Initial Value | R/W | Description |
|-----|----------|---------------|-----|--|
| 2 | SW2 | 1 | R/W | <p>\overline{CS} assert period extension for CS2 and CS6 spaces</p> <p>This bit inserts a cycle to prevent the assert period of \overline{RD} and \overline{WRx} from extending the assert period of $\overline{CS2}$ and $\overline{CS6}$.</p> <p>0: No cycle inserted for \overline{CS} assert period for CS2 and CS6 spaces.</p> <p>1: \overline{CS} assert extension for CS2 and CS6 spaces. (Each one cycle inserted before and after the bus cycle)</p> |
| 1 | SW1 | 1 | R/W | <p>\overline{CS} assert period extension for CS1 and CS5 spaces</p> <p>This bit inserts a cycle to prevent the assert period of \overline{RD} and \overline{WRx} from extending the assert period of $\overline{CS1}$ and $\overline{CS5}$.</p> <p>0: No cycle inserted for \overline{CS} assert period for CS1 and CS5 spaces.</p> <p>1: \overline{CS} assert extension for CS1 and CS5 spaces. (Each one cycle inserted before and after the bus cycle)</p> |
| 0 | SW0 | 1 | R/W | <p>\overline{CS} assert period extension for CS0 and CS4 spaces</p> <p>This bit inserts a cycle to prevent the assert period of \overline{RD} and \overline{WRx} from extending the assert period of $\overline{CS0}$ and $\overline{CS4}$.</p> <p>0: No cycle inserted for \overline{CS} assert period for CS0 and CS4 spaces.</p> <p>1: \overline{CS} assert extension for CS0 and CS4 spaces. (Each one cycle inserted before and after the bus cycle)</p> |

9.5.3 Wait Control Register 1 (WCR1)

WCR1 is a 16-bit readable/writable register that specifies the number of wait cycles (0 to 15) for each CS space.

| Bit | Bit Name | Initial Value | R/W | Description |
|-----|----------|---------------|-----|---|
| 15 | W33 | 1 | R/W | CS3 and CS7 Space Wait Specification |
| 14 | W32 | 1 | R/W | These bits specify the number of waits for CS3 and CS7 space access. 0000: No wait (external wait input disabled) 0001: One wait (external wait input enabled) ⋮ 1111: 15 waits (external wait input enabled) |
| 13 | W31 | 1 | R/W | |
| 12 | W30 | 1 | R/W | |
| 11 | W23 | 1 | R/W | |
| 10 | W22 | 1 | R/W | CS2 and CS6 Space Wait Specification These bits specify the number of waits for CS2 and CS6 space access. 0000: No wait (external wait input disabled) 0001: One wait (external wait input enabled) ⋮ 1111: 15 waits (external wait input enabled) |
| 9 | W21 | 1 | R/W | |
| 8 | W20 | 1 | R/W | |
| 7 | W13 | 1 | R/W | |
| 6 | W12 | 1 | R/W | CS1 and CS5 Space Wait Specification These bits specify the number of waits for CS1 and CS5 space access. 0000: No wait (external wait input disabled) 0001: One wait (external wait input enabled) ⋮ 1111: 15 waits (external wait input enabled) |
| 5 | W11 | 1 | R/W | |
| 4 | W10 | 1 | R/W | |
| 3 | W03 | 1 | R/W | |
| 2 | W02 | 1 | R/W | CS0 and CS4 Space Wait Specification These bits specify the number of waits for CS0 and CS4 space access. 0000: No wait (external wait input disabled) 0001: One wait (external wait input enabled) ⋮ 1111: 15 waits (external wait input enabled) |
| 1 | W01 | 1 | R/W | |
| 0 | W00 | 1 | R/W | |
| | | | | |

9.5.4 Wait Control Register 2 (WCR2)

WCR2 is a 16-bit readable/writable register that specifies the number of access cycles to the CS space in DMA single address mode transfer.

Do not perform DMA single address transfer before setting WCR2.

| Bit | Bit Name | Initial Value | R/W | Description |
|---------|----------|---------------|-----|---|
| 15 to 4 | — | All 0 | R | Reserved These bits are always read as 0. The write value should always be 0. |
| 3 | DSW3 | 1 | R/W | Number of wait cycles for access to CS space in DMA single address mode These bits specify the number of wait cycles (0 to 15) for access to the CS space in DMA single address mode. These bits are independent of the W bit in WCR1. 0000: No wait (external wait insertion disabled) 0001: One wait (external wait insertion enabled) : 1111: 15 waits (external waits insertion enabled) |
| 2 | DSW2 | 1 | R/W | |
| 1 | DSW1 | 1 | R/W | |
| 0 | DSW0 | 1 | R/W | |

9.5.5 RAM Emulation Register (RAMER)

RAMER is a 16-bit readable/writable register that selects the RAM area to be used when emulating realtime programming of flash memory. For details, refer to section 19.5.5, RAM Emulation Register (RAMER).

9.6 Accessing External Space

A strobe signal is output in external space accesses to provide primarily for SRAM or ROM direct connections.

9.6.1 Basic Timing

External access bus cycles are performed in 2 states. Figure 9.3 shows the basic timing of external space access.

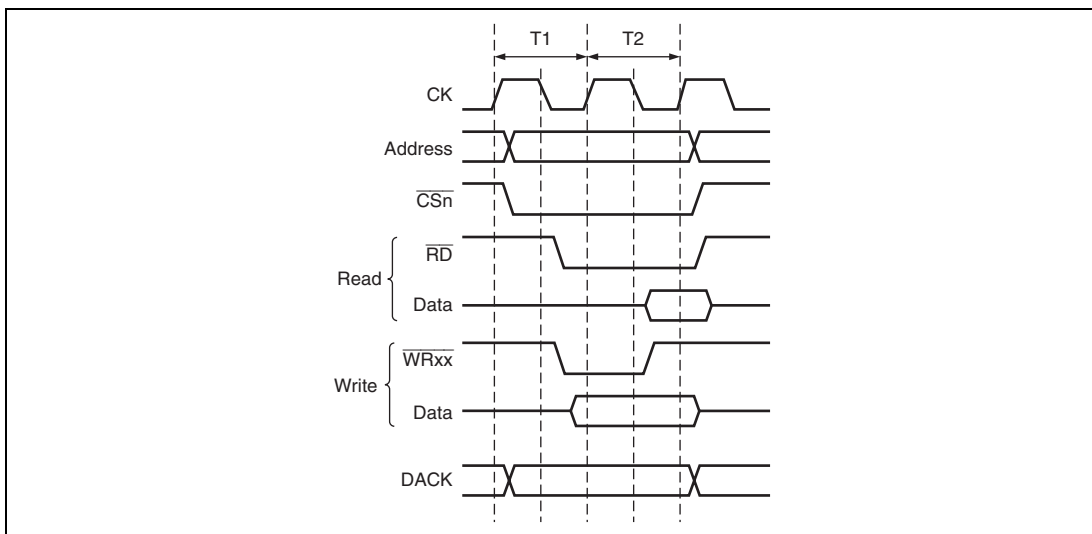

Figure 9.3 Basic Timing of External Space Access

During a read, irrespective of operand size, all bits in the data bus width for the access space (address) accessed by \overline{RD} signal are fetched by the LSI.

During a write, the \overline{WRHH} (bits 31 to 24), the \overline{WRHL} (bits 23 to 16), the \overline{WRH} (bits 15 to 8), and the \overline{WRL} (bits 7 to 0) signal indicate the byte location to be written.

9.6.2 Wait State Control

The number of wait states inserted into external space access states can be controlled using the WCR settings. The specified number of T_w cycles are inserted as software cycles at the timing shown in figure 9.4.

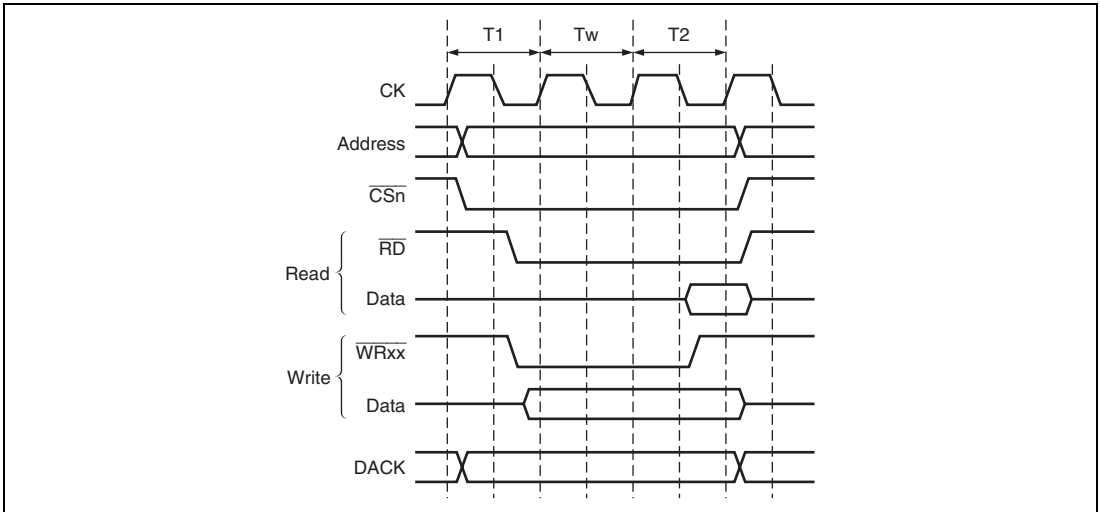
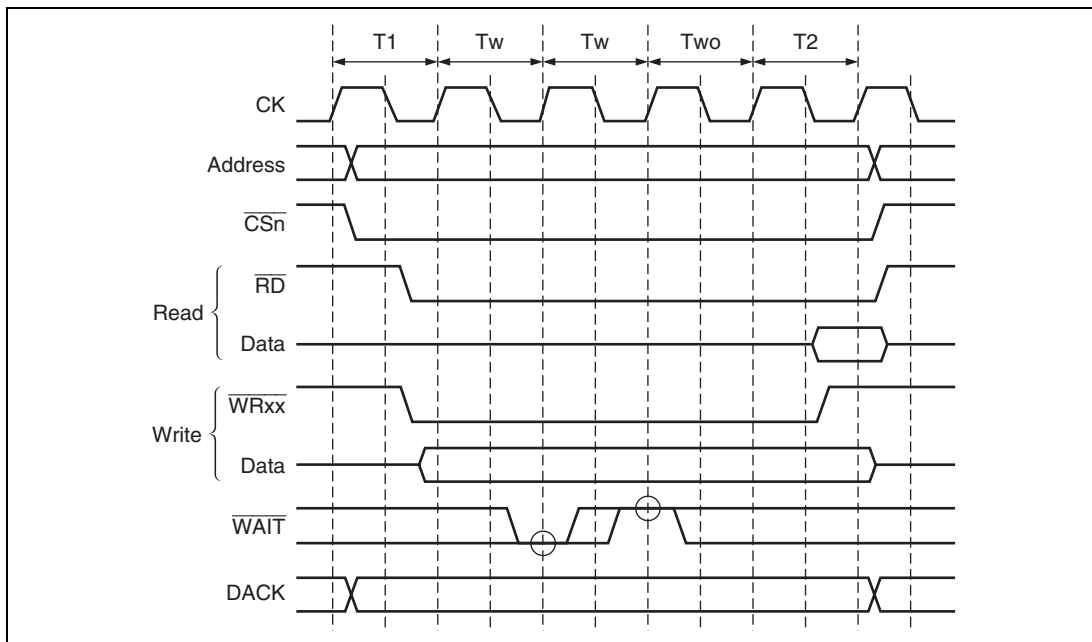

Figure 9.4 Wait State Timing of External Space Access (Software Wait Only)

When the wait is specified by software using WCR, the wait input $\overline{\text{WAIT}}$ signal from outside is sampled. Figure 9.5 shows the $\overline{\text{WAIT}}$ signal sampling. The $\overline{\text{WAIT}}$ signal is sampled at the clock rise one cycle before the clock rise when the Tw state shifts to the T2 state.



**Figure 9.5 Wait State Timing of External Space Access
(Two Software Wait States + $\overline{\text{WAIT}}$ Signal Wait State)**

9.6.3 $\overline{\text{CS}}$ Assert Period Extension

Idle cycles can be inserted to prevent extension of the $\overline{\text{RD}}$ or $\overline{\text{WRxx}}$ signal assert period beyond the length of the $\overline{\text{CSn}}$ signal assert period by setting the SW3 to SW0 bits of BCR2. This allows for flexible interfaces with external circuitry. The timing is shown in figure 9.6. T_h and T_f cycles are added respectively before and after the normal cycle. Only $\overline{\text{CSn}}$ is asserted in these cycles; $\overline{\text{RD}}$ and $\overline{\text{WRxx}}$ signals are not. Further, data is extended up to the T_f cycle, which is effective for gate arrays and the like, which have slower write operations.

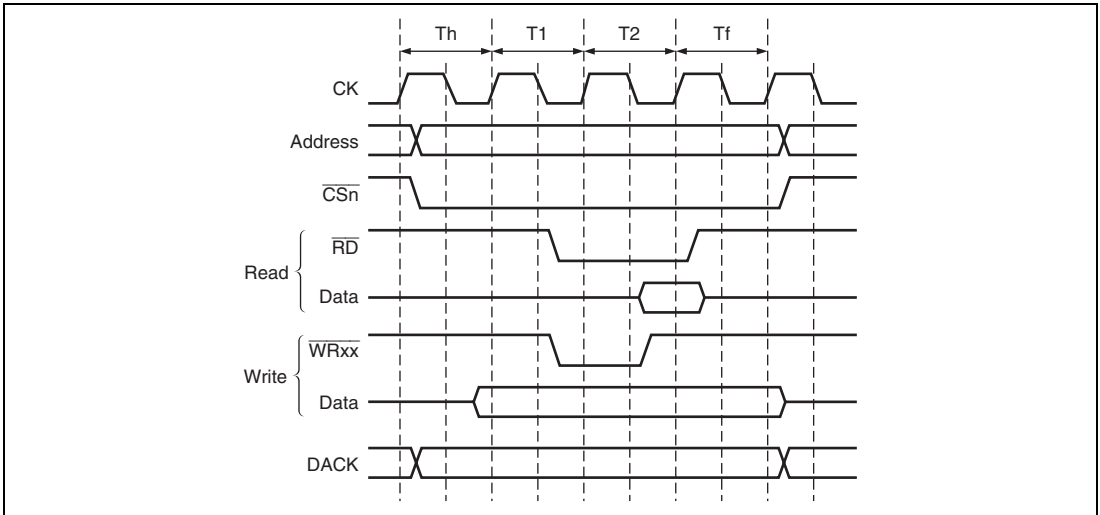

Figure 9.6 $\overline{\text{CS}}$ Assert Period Extension Function

9.7 Waits between Access Cycles

When a read from a slow device is completed, data buffers may not go off in time, causing conflict with the next access data. If there is a data conflict during memory access, the problem can be solved by inserting a wait in the access cycle.

To enable detection of bus cycle starts, waits can be inserted between access cycles during continuous accesses of the same CS space by negating the \overline{CSn} signal once.

9.7.1 Prevention of Data Bus Conflicts

Wait cycles are inserted in the following cases so that the number of idle cycles specified with the IW31 to IW00 bits are inserted:

- The write cycle to the same CS space continues after the cycle read
- The continuous access is made to the different CS space after the read access

If there are idle cycles between the access cycles, the number of wait cycles is inserted that is obtained by subtracting the existing idle cycles from the number of idle cycles specified.

Figure 9.7 shows the example of idle cycle insertion. In this example, when one idle cycle insertion is specified between CSn space cycles, the specified one idle cycle is inserted when the write access is performed to the CSm space immediately after the read cycle of the CSn space.

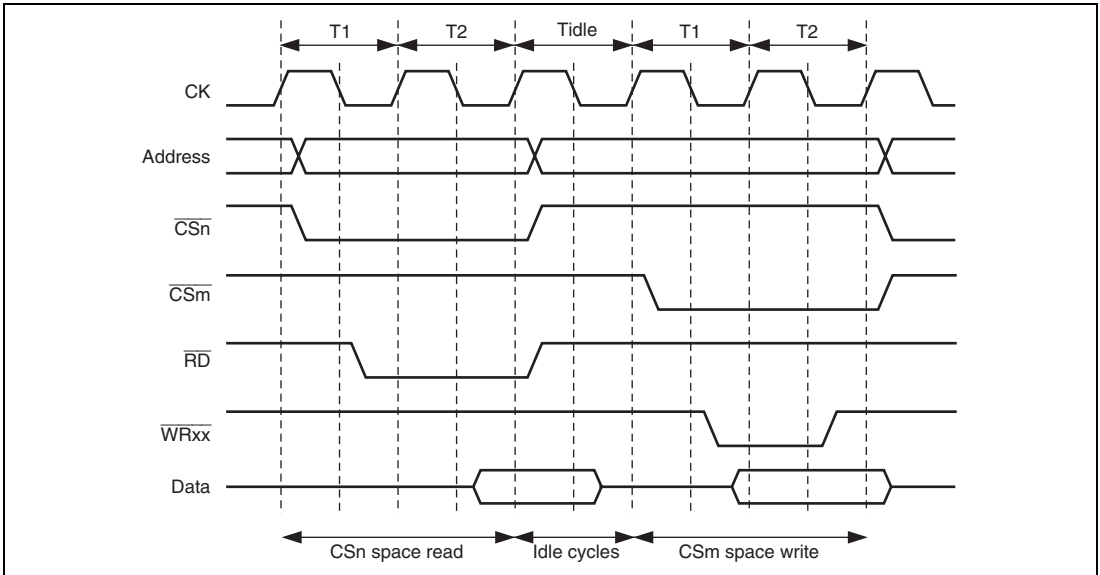

Figure 9.7 Example of Idle Cycle Insertion

Bits IW31 and IW30 in BCR2 specify the number of idle cycles inserted in the case of a write cycle to CS3 and CS7 spaces or a read access to different space after CS3 and CS7 space read.

Bits IW21 and IW20 specify the number of idle cycles inserted for CS2 and CS6 spaces, bits IW11 and IW10 specify for CS1 and CS5 spaces, and bits IW01 and IW00 specify for CS0 and CS4 spaces, respectively.

9.7.2 Simplification of Bus Cycle Start Detection

For consecutive accesses to the same CS space, waits are inserted to provide the number of idle cycles designated by bits CW3 to CW0 in BCR2. However, in the case of a write cycle after a read, the number of idle cycles inserted will be the larger of the two values designated by the IW and CW bits. When idle cycles already exist between access cycles, waits are not inserted.

Figure 9.8 shows an example. A continuous access idle is specified for CSn space, and CSn space is consecutively write-accessed.

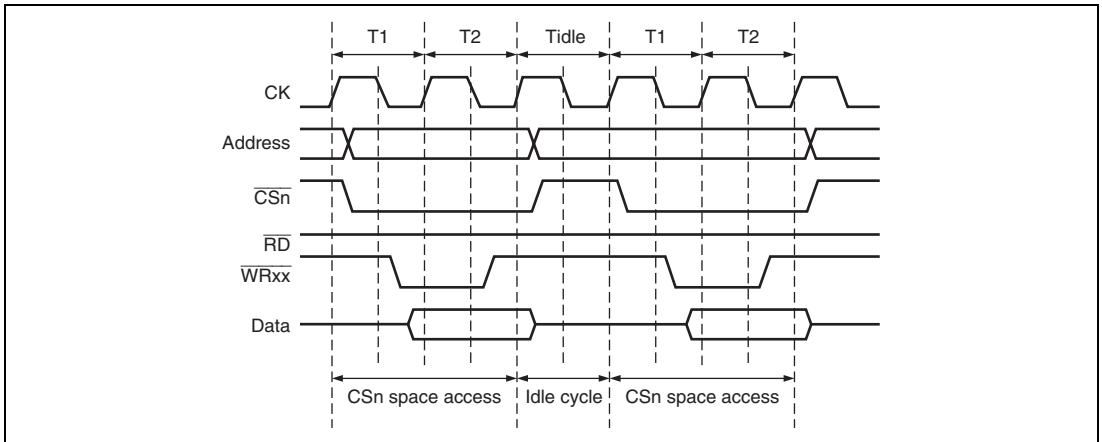

Figure 9.8 Example of Idle Cycle Insertion at Same Space Consecutive Access

9.8 Bus Arbitration

This LSI has a bus arbitration function that, when a bus release request is received from an external device, releases the bus to that device. It also has four internal bus masters, the CPU, DMAC, DTC, and AUD. The priority for arbitrate the bus mastership between these bus masters is:

Bus request from external device > AUD > DTC > DMAC > CPU

AUD does not acquire the bus mastership during DTC or DMAC burst transfer; it acquires the bus mastership after DTC or DMAC burst transfer. AUD has the priority for the bus mastership to DTC and DMAC if the CPU has the bus mastership. DMAC, continues operating even if DTC requests the bus mastership during the read or the write period in DMAC dual address mode, during burst transfer, or during operation in indirect address transfer mode.

A bus request by an external device should be input to the $\overline{\text{BREQ}}$ pin. When the $\overline{\text{BREQ}}$ pin is asserted, this LSI releases the bus immediately after executing the current bus cycle. The signal indicating that the bus has been released is output from the $\overline{\text{BACK}}$ pin.

However, the bus arbitration is not performed at the timing between the read cycle and the write cycle of TAS instruction. In addition, bus arbitration is not performed during bus cycle if the access size is greater than the data-bus size, for example, when a long-word access is made for an 8-bit size memory.

When an interrupt is generated and the CPU must process this interrupt, the LSI must take back the bus mastership. For this purpose, this LSI has the $\overline{\text{IRQOUT}}$ pin used for the bus mastership request signal. Before the LSI takes back the bus mastership, the $\overline{\text{IRQOUT}}$ signal is asserted. When the $\overline{\text{IRQOUT}}$ signal is asserted, the device that asserted the external bus release request negates the $\overline{\text{BREQ}}$ signal to release the bus mastership. This allows the bus mastership to return to the CPU, and the LSI processes the interrupt. The $\overline{\text{IRQOUT}}$ pin is asserted when a cause of interrupt is generated and the interrupt request level is higher than the interrupt mask bits (I3 to I0) of the status register (SR).

Figure 9.9 shows a bus mastership release procedure.

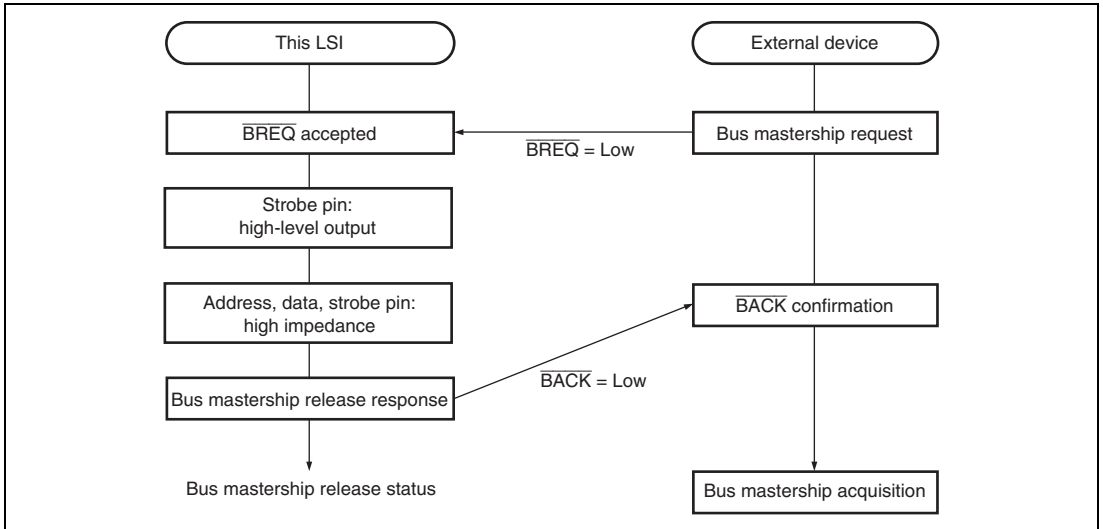

Figure 9.9 Bus Mastership Release Procedure

9.9 Memory Connection Example

Since A21 to A18 function as input ports at power-on reset, take the procedure such as pulling down as required.

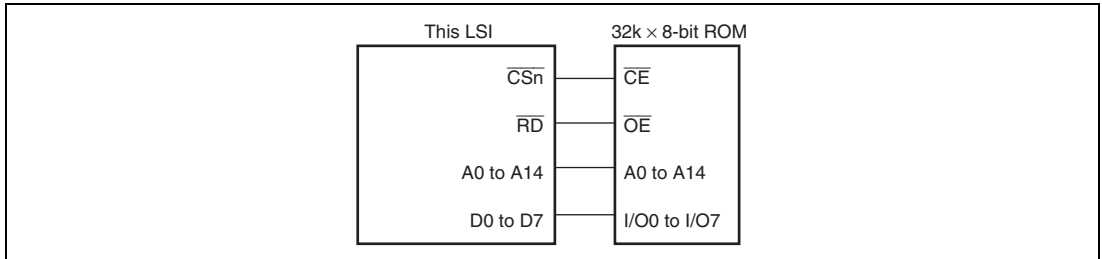

Figure 9.10 Example of 8-bit Data Bus Width ROM Connection

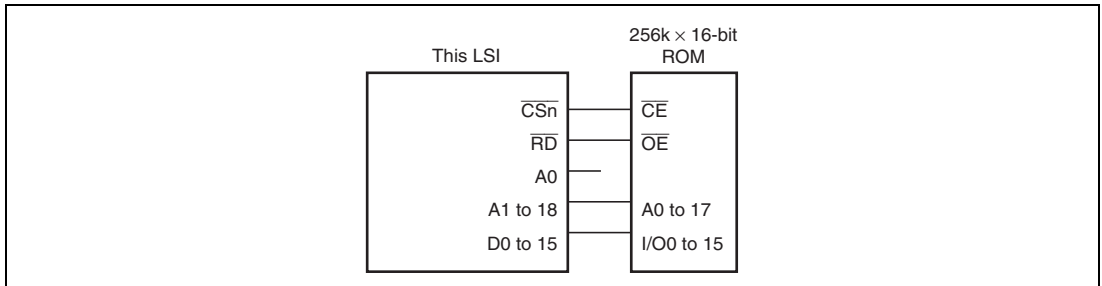

Figure 9.11 Example of 16-bit Data Bus Width ROM Connection

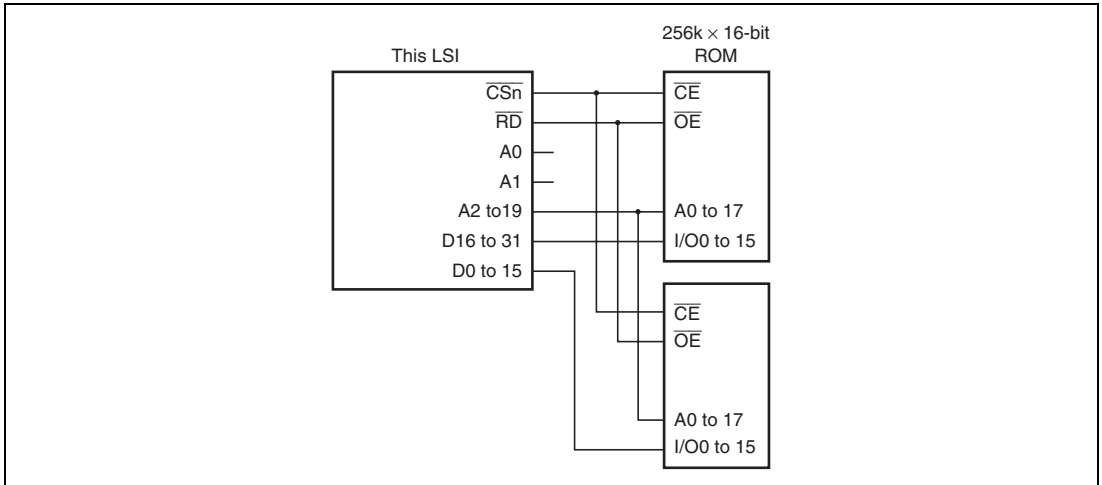

Figure 9.12 Example of 32-bit Data Bus Width ROM Connection (only for SH7145)

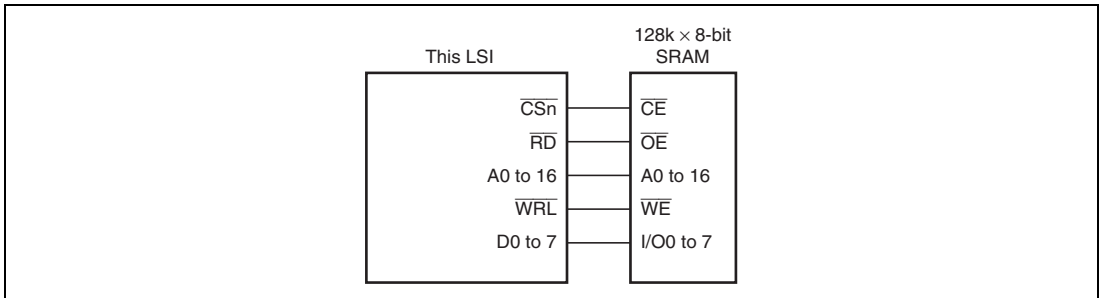

Figure 9.13 Example of 8-bit Data Bus Width SRAM Connection

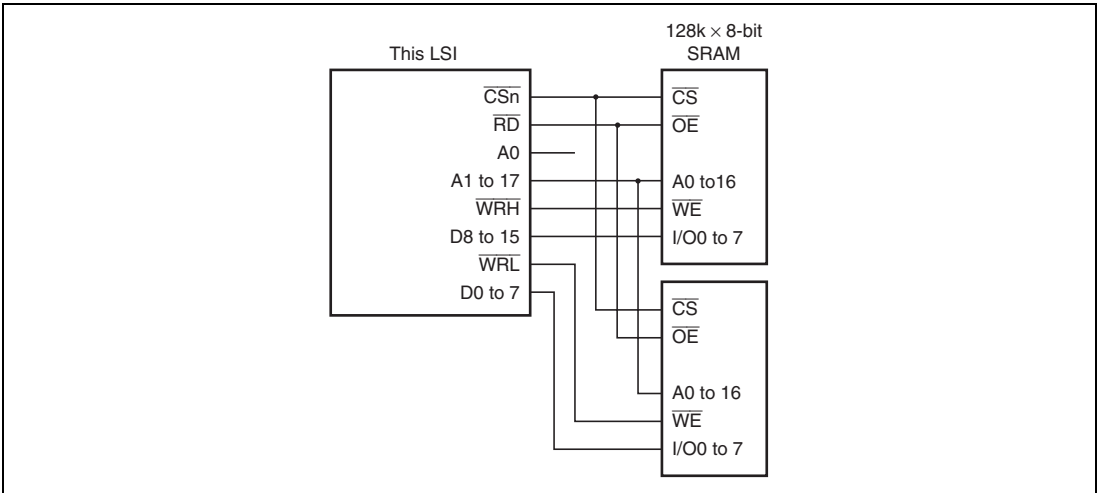

Figure 9.14 Example of 16-bit Data Bus Width SRAM Connection

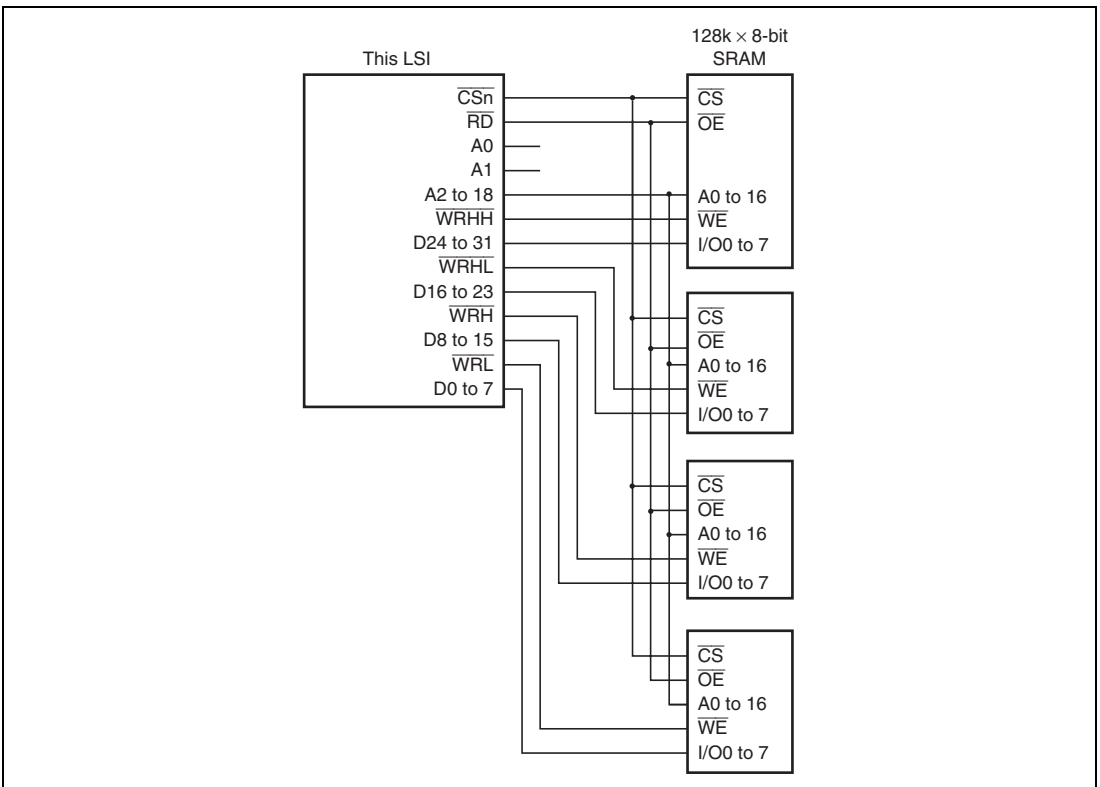

Figure 9.15 Example of 32-bit Data Bus Width SRAM Connection (only for SH7145)

9.10 Access to On-chip Peripheral I/O Registers

On-chip peripheral I/O registers are accessed from the bus state controller as shown in table 9.3. Refer to section 25, List of Registers, for more details.

Table 9.3 Access to On-chip Peripheral I/O Registers

| On-chip peripheral module | SCI | MTU, POE | INTC | PFC, PORT | CMT | A/D | UBC | WDT | DMAC | DTC | IIC | H-UDI |
|---------------------------|--------|----------|---------|-----------|---------|--------|---------|---------|---------|---------|--------|---------|
| Connection bus width | 8 bits | 16 bits | 16 bits | 16 bits | 16 bits | 8 bits | 16 bits | 16 bits | 16 bits | 16 bits | 8 bits | 16 bits |
| Number of access cycles | 2 cyc | 2 cyc | 2 cyc | 2 cyc | 2 cyc | 3 cyc | 3 cyc | 3 cyc | 3 cyc | 3 cyc | 2 cyc | 2 cyc |

9.11 Cycles of No-Bus Mastership Release

The bus mastership is not released during one bus cycle. For example, when the longword read (or write) access is performed to the 8-bit normal space, four memory accesses to the 8-bit normal space are regarded as one bus cycle. In this bus cycle, the bus mastership is not released. In this case, assuming that one memory access takes two states, the bus mastership is not released in eight states.

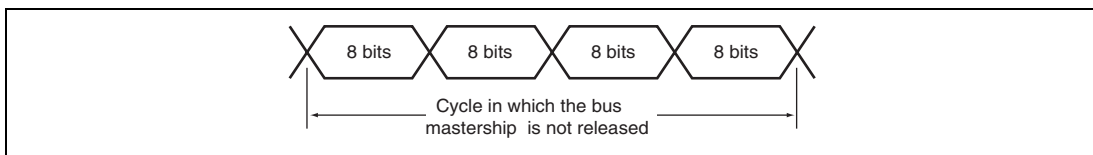

Figure 9.16 One Bus Cycle

9.12 CPU Operation when Program Is Located in External Memory

In this LSI, two words (two instructions) are fetched in one instruction fetch. This also applies to the cases where program is located in external memory or the bus width of that external memory is 8 or 16 bits.

Also, if the program counter value is the odd word ($2n+1$) address or the program counter value before branch is the even word ($2n$) address, 32 bits (two instructions) including each word instruction are always fetched.

Section 10 Direct Memory Access Controller (DMAC)

This LSI includes an on-chip four-channel direct memory access controller (DMAC). The DMAC can be used in place of the CPU to perform high-speed data transfers among external devices equipped with DACK (transfer request acknowledge signal), external memories, memory-mapped external devices, and on-chip peripheral modules (except for the DMAC, DTC, BSC, and UBC). Using the DMAC reduces the burden on the CPU and increases operating efficiency of the LSI as a whole.

10.1 Features

- Four channels
- Four Gbytes of address space in the architecture
- Byte, word, or longword selectable data transfer unit
- 16,777,216 transfers, maximum
- Address mode
 - Dual address mode or single address mode can be selected.
 - Direct access or indirect access can be selected in dual address mode.
- Channel function: Transfer modes that can be set are different for each channel.
 - Channel 0: Single or dual address mode. External requests are accepted.
 - Channel 1: Single or dual address mode. External requests are accepted.
 - Channel 2: Dual address mode only. Source address reload function is available.
 - Channel 3: Dual address mode only. Direct address transfer mode and indirect address transfer mode selectable.
- Transfer requests: There are three DMAC transfer activation requests, as indicated below.
 - External request: From two $\overline{\text{DREQ}}$ pins. DREQ can be detected either by falling edge or by low level.
 - Requests from on-chip peripheral modules: Transfer requests from on-chip modules such as SCI (request made to SCI_0 and SCI_1) or A/D (request made to A/D 1).
 - Auto-request: The transfer request is generated automatically within the DMAC.
- Selectable bus modes: Cycle-steal mode or burst mode
- Two types of DMAC channel priority ranking: Fixed priority mode or round robin mode
- CPU can be interrupted when the specified number of data transfers are complete.
- Module standby mode can be set.

Figure 10.1 is a block diagram of the DMAC.

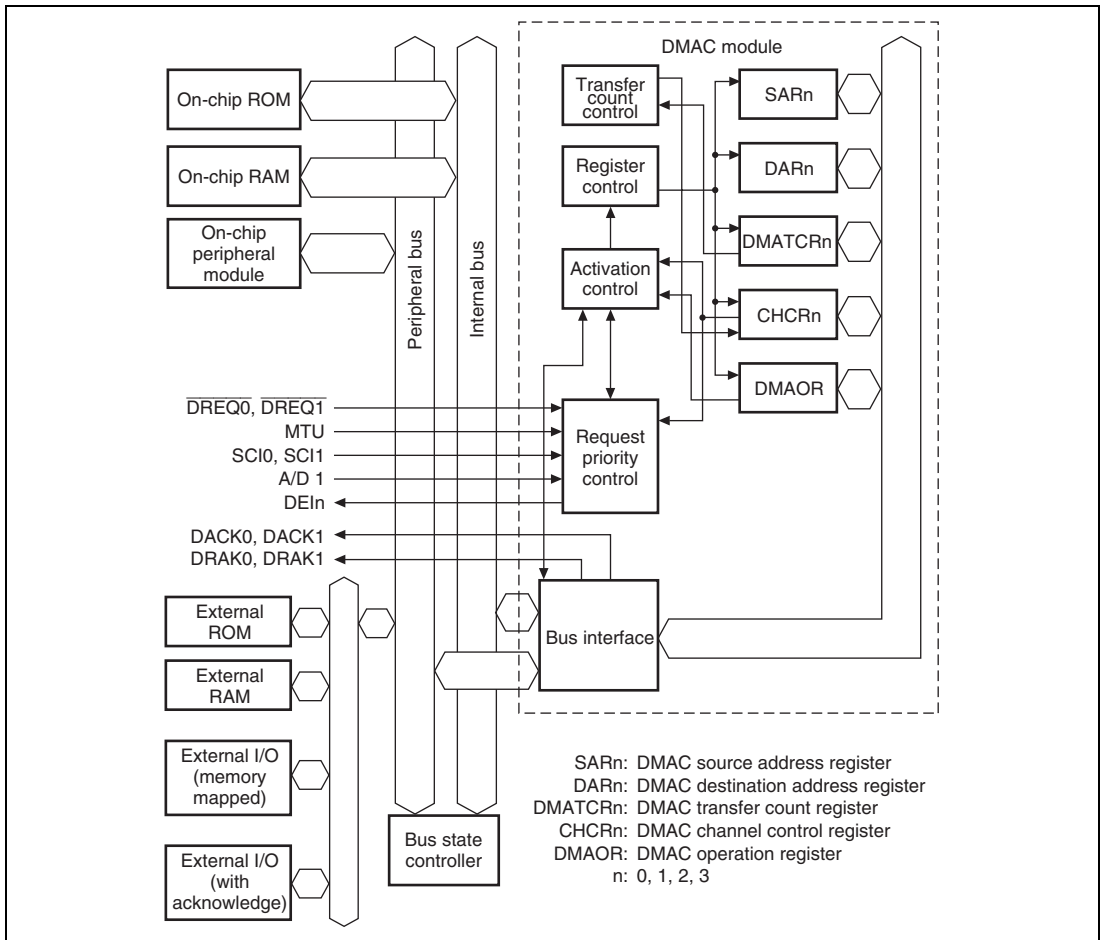

Figure 10.1 DMAC Block Diagram

10.2 Input/Output Pins

Table 10.1 shows the DMAC pin configuration.

Table 10.1 DMAC Pin Configuration

| Channel | Name | Symbol | I/O | Function |
|---------|---|---------------------------|-----|---|
| 0 | DMA transfer request | $\overline{\text{DREQ0}}$ | I | DMA transfer request input from external device to channel 0 |
| | DMA transfer request acknowledge | DACK0 | O | DMA transfer strobe output from channel 0 to external device |
| | $\overline{\text{DREQ0}}$ acceptance confirmation | DRAK0 | O | Sampling receive acknowledge output for DMA transfer request input from external source |
| 1 | DMA transfer request | $\overline{\text{DREQ1}}$ | I | DMA transfer request input from external device to channel 1 |
| | DMA transfer request acknowledge | DACK1 | O | DMA transfer strobe output from channel 1 to external device |
| | $\overline{\text{DREQ1}}$ acceptance confirmation | DRAK1 | O | Sampling receive acknowledge output for DMA transfer request input from external source |

10.3 Register Descriptions

The DMAC has the following registers. The DMAC has a total of 17 registers. Each channel has four control registers. One other control register is shared by all channels. For register address and their states in each operating mode, refer to section 25, List of Registers.

- DMA source address register_0 (SAR_0)
- DMA destination address register_0 (DAR_0)
- DMA transfer count register_0 (DMATCR_0)
- DMA channel control register_0 (CHCR_0)
- DMA source address register_1 (SAR_1)
- DMA destination address register_1 (DAR_1)
- DMA transfer count register_1 (DMATCR_1)
- DMA channel control register_1 (CHCR_1)
- DMA source address register_2 (SAR_2)
- DMA destination address register_2 (DAR_2)
- DMA transfer count register_2 (DMATCR_2)
- DMA channel control register_2 (CHCR_2)
- DMA source address register_3 (SAR_3)
- DMA destination address register_3 (DAR_3)
- DMA transfer count register_3 (DMATCR_3)
- DMA channel control register_3 (CHCR_3)
- DMA operation register (DMAOR)

10.3.1 DMA Source Address Registers_0 to 3 (SAR_0 to SAR_3)

DMA source address registers_0 to 3 (SAR_0 to SAR_3) are 32-bit readable/writable registers that specify the source address of a DMA transfer. These registers have a count function, and during a DMA transfer, they indicate the next source address. In single-address mode, SAR values are ignored when a device with DACK has been specified as the transfer source.

Specify a 16-bit or 32-bit boundary address when doing 16-bit or 32-bit data transfers. Operation cannot be guaranteed on any other addresses.

When this register is accessed in 16 bits, the value of another 16 bits that are not accessed is retained.

The initial value of SAR is undefined.

10.3.2 DMA Destination Address Registers_0 to 3 (DAR_0 to DAR_3)

DMA destination address registers_0 to 3 (DAR_0 to DAR_3) are 32-bit readable/writable registers that specify the destination address of a DMA transfer. These registers have a count function, and during a DMA transfer, they indicate the next destination address. In single-address mode, DAR values are ignored when a device with DACK has been specified as the transfer destination.

Specify a 16-bit or 32-bit boundary address when doing 16-bit or 32-bit data transfers. Operation cannot be guaranteed on any other address. When this register is accessed in 16 bits, the value of another 16 bits that are not accessed is retained.

The initial value of DAR is undefined.

10.3.3 DMA Transfer Count Registers_0 to 3 (DMATCR_0 to DMATCR_3)

DMA transfer count registers_0 to 3 (DMATCR_0 to DMATCR_3) are 32-bit readable/writable registers that specify the transfer count for each channel (byte count, word count, or longword count) with lower 24 bits. Specifying a H'000001 gives a transfer count of 1, while H'000000 gives the maximum setting, 16,777,216 transfers. While DMAC is in operation, the number of transfers to be performed is indicated.

Upper eight bits of this register are read as 0 and the write value should always be 0. When this register is accessed in 16 bits, the value of another 16 bits that are not accessed is retained.

The initial value of DMATCR is undefined.

10.3.4 DMA Channel Control Registers_0 to 3 (CHCR_0 to CHCR_3)

DMA channel control registers_0 to 3 (CHCR_0 to CHCR_3) are 32-bit readable/writable registers where the operation and transmission of each channel is designated.

| Bit | Bit Name | Initial Value | R/W | Description |
|----------------|----------|---------------|---------------------|---|
| 31 to 21 | — | All 0 | R | Reserved These bits are always read as 0. The write value should always be 0. |
| 20 | DI | 0 | (R/W)* ² | Direct/Indirect Specifies either direct address mode operation or indirect address mode operation for channel 3 source address. This bit is valid only in CHCR_3. For CHCR_0 to CHCR_2, this bit is always read as 0 and the write value should always be 0. 0: Direct access mode operation for channel 3 1: Indirect access mode operation for channel 3 |
| 19 | RO | 0 | (R/W)* ² | Source Address Reload Selects whether to reload the source address initial value during channel 2 transfer. This bit is valid only for CHCR_2. For CHCR_0, CHCR_1, and CHCR_3, this bit is always read as 0 and the write value should always be 0. 0: Does not reload source address 1: Reloads source address |
| 18 | RL | 0 | (R/W)* ² | Request Check Level Selects whether to output DRAK notifying external device of DREQ received, with active high or active low. This bit is valid only for CHCR_0 and CHCR_1. For CHCR_2 and CHCR_3, this bit is always read as 0 and the write value should always be 0. 0: Output DRAK with active high 1: Output DRAK with active low |

| Bit | Bit Name | Initial Value | R/W | Description |
|-----|----------|---------------|---------------------|---|
| 17 | AM | 0 | (R/W)* ² | <p>Acknowledge Mode</p> <p>In dual address mode, selects whether to output DACK in the data write cycle or data read cycle. In single address mode, DACK is always output irrespective of the setting of this bit. This bit is valid only for CHCR_0 and CHCR_1. For CHCR_2 and CHCR_3, this bit is always read as 0 and the write value should always be 0.</p> <p>0: Outputs DACK during read cycle 1: Outputs DACK during write cycle</p> |
| 16 | AL | 0 | (R/W)* ² | <p>Acknowledge Level</p> <p>Specifies whether to set DACK (acknowledge) signal output to active high or active low. This bit is valid only with CHCR_0 and CHCR_1. For CHCR_2 and CHCR_3, this bit is always read as 0 and the write value should always be 0.</p> <p>0: Active high output 1: Active low output</p> |
| 15 | DM1 | 0 | R/W | Destination Address Mode 1, 0 |
| 14 | DM0 | 0 | R/W | <p>These bits specify increment/decrement of the DMA transfer destination address. These bit specifications are ignored when transferring data from an external device to address space in single address mode.</p> <p>00: Destination address fixed 01: Destination address incremented (+1 during 8-bit transfer, +2 during 16-bit transfer, +4 during 32-bit transfer) 10: Destination address decremented (−1 during 8-bit transfer, −2 during 16-bit transfer, −4 during 32-bit transfer) 11: Setting prohibited</p> |

| Bit | Bit Name | Initial Value | R/W | Description |
|-----|----------|---------------|-----|---|
| 13 | SM1 | 0 | R/W | Source Address Mode 1, 0 |
| 12 | SM0 | 0 | R/W | <p>These bits specify increment/decrement of the DMA transfer source address. These bit specifications are ignored when transferring data from an external device to address space in single address mode.</p> <p>00: Source address fixed</p> <p>01: Source address incremented (+1 during 8-bit transfer, +2 during 16-bit transfer, +4 during 32-bit transfer)</p> <p>10: Source address decremented (-1 during 8-bit transfer, -2 during 16-bit transfer, -4 during 32-bit transfer)</p> <p>11: Setting prohibited</p> <p>When the transfer source is specified at an indirect address, specify in source address register 3 (SAR_3) the actual storage address of the data you want to transfer as the data storage address (indirect address).</p> <p>During indirect address mode, SAR_3 obeys the SM1/SM0 setting for increment/decrement. In this case, SAR_3's increment/decrement is fixed at +4/-4 or 0, irrespective of the transfer data size specified by TS1 and TS0.</p> |

| Bit | Bit Name | Initial Value | R/W | Description | |
|-----|----------|---------------|-----|---|--|
| 11 | RS3 | 0 | R/W | Resource Select 3, 2, 1, 0 | |
| 10 | RS2 | 0 | R/W | These bits specify the transfer request source. 0000: External request, dual address mode 0001: Prohibited 0010: External request, single address mode. External address space → external device. 0011: External request, single address mode. External device → external address space. 0100: Auto-request 0101: Prohibited 0110: MTU TGIA_0 0111: MTU TGIA_1 1000: MTU TGIA_2 1001: MTU TGIA_3 1010: MTU TGIA_4 1011: A/D1 ADI1 1100: SCI0 TXI_0 1101: SCI0 RXI_0 1110: SCI1 TXI_1 1111: SCI1 RXI_1 Note: External request designations are valid only for channels 0 and 1. No transfer request sources can be set for channels 2 or 3. | |
| 9 | RS1 | 0 | R/W | | |
| 8 | RS0 | 0 | R/W | | |
| 7 | — | 0 | R | | Reserved |
| | | | | | This bit is always read as 0. The write value should always be 0 |

| Bit | Bit Name | Initial Value | R/W | Description |
|-----|----------|---------------|---------------------|--|
| 6 | DS | 0 | (R/W)* ² | <p>DREQ Select</p> <p>Sets the sampling method for the $\overline{\text{DREQ}}$ pin in external request mode to either low-level detection or falling-edge detection. This bit is valid only with CHCR_0 and CHCR_1. For CHCR_2 and CHCR_3, this bit is always read as 0 and the write value should always be 0.</p> <p>Even with channels 0 and 1, when specifying an on-chip peripheral module or auto-request as the transfer request source, this bit setting is ignored. The sampling method is fixed at falling-edge detection in cases other than auto-request.</p> <p>0: Low-level detection 1: Falling-edge detection</p> |
| 5 | TM | 0 | R/W | <p>Transfer Mode</p> <p>Specifies the bus mode for data transfer.</p> <p>0: Cycle steal mode 1: Burst mode</p> |
| 4 | TS1 | 0 | R/W | <p>Transfer Size 1, 0</p> <p>Specify size of data for transfer.</p> <p>00: Specifies byte size (8 bits) 01: Specifies word size (16 bits) 10: Specifies longword size (32 bits) 11: Prohibited</p> |
| 3 | TS0 | 0 | R/W | |
| 2 | IE | 0 | R/W | <p>Interrupt Enable</p> <p>When this bit is set to 1, interrupt requests are generated after the number of data transfers specified in the DMATCR (when TE = 1).</p> <p>0: Interrupt request not generated after DMATCR-specified transfer count 1: Interrupt request enabled on completion of DMATCR specified number of transfers</p> |

| Bit | Bit Name | Initial Value | R/W | Description |
|-----|----------|---------------|---------------------|---|
| 1 | TE | 0 | R/(W)* ¹ | <p>Transfer End Flag</p> <p>This bit is set to 1 after the number of data transfers specified by the DMATCR. At this time, if the IE bit is set to 1, an interrupt request is generated.</p> <p>If data transfer ends before TE is set to 1 (for example, due to an NMI or address error, or clearing of the DE bit or DME bit of the DMAOR) the TE is not set to 1. With this bit set to 1, data transfer is disabled even if the DE bit is set to 1.</p> <p>0: DMATCR-specified transfer count not ended</p> <p>[Clearing condition]</p> <p>0 write after TE = 1 read, power-on reset, software standby mode</p> <p>1: DMATCR specified number of transfers completed</p> |
| 0 | DE | 0 | R/W | <p>DMAC Enable</p> <p>DE enables operation in the corresponding channel.</p> <p>0: Operation of the corresponding channel disabled</p> <p>1: Operation of the corresponding channel enabled</p> <p>Transfer mode is entered if this bit is set to 1 when auto-request is specified (RS3 to RS0 settings). With an external request or on-chip module request, when a transfer request occurs after this bit is set to 1, transfer is enabled. If this bit is cleared during a data transfer, transfer is suspended.</p> <p>If the DE bit has been set, but TE = 1, then if the DME bit of the DMAOR is 0, and the NMI or AE bit of the DMAOR is 1, transfer enable mode is not entered.</p> |

Notes: 1. TE bit: Allows only 0 write after reading 1.

2. The DI, RO, RL, AM, AL, or DS bit may be absent, depending on the channel.

10.3.5 DMAC Operation Register (DMAOR)

The DMAOR is a 16-bit readable/writable register that specifies the transfer mode of the DMAC

| Bit | Bit Name | Initial Value | R/W | Description |
|----------|----------|---------------|--------|--|
| 15 to 10 | — | All 0 | R | Reserved These bits are always read as 0. The write value should always be 0. |
| 9 | PR1 | 0 | R/W | Priority Mode 1 and 0 |
| 8 | PRO | 0 | R/W | These bits determine the priority level of channels for execution when transfer requests are made for several channels simultaneously. 00: CH0 > CH1 > CH2 > CH3 01: CH0 > CH2 > CH3 > CH1 10: CH2 > CH0 > CH1 > CH3 11: Round robin mode |
| 7 to 3 | — | All 0 | R | Reserved These bits are always read as 0. The write value should always be 0. |
| 2 | AE | 0 | R/(W)* | Address Error Flag Indicates that an address error has occurred during DMA transfer. If this bit is set during a data transfer, transfers on all channels are suspended. The CPU cannot write a 1 to the AE bit. Clearing is effected by 0 write after 1 read. 0: No address error, DMA transfer enabled [Clearing condition] Write AE = 0 after reading AE = 1 1: Address error, DMA transfer disabled [Setting condition] Address error due to DMAC |

| Bit | Bit Name | Initial Value | R/W | Description |
|-----|----------|---------------|--------|--|
| 1 | NMIF | 0 | R/(W)* | <p>NMI Flag</p> <p>Indicates input of an NMI. This bit is set irrespective of whether the DMAC is operating or suspended. If this bit is set during a data transfer, transfers on all channels are suspended. The CPU is unable to write a 1 to the NMIF. Clearing is effected by a 0 write after 1 read.</p> <p>0: No NMI interrupt, DMA transfer enabled</p> <p>[Clearing condition] Write NMIF = 0 after reading NMIF = 1</p> <p>1: NMI has occurred, DMA transfer prohibited</p> <p>[Setting condition] NMI interrupt occurrence</p> |
| 0 | DME | 0 | R/W | <p>DMAC Master Enable</p> <p>This bit enables activation of the entire DMAC. When the DME bit and DE bit of the CHCR for the corresponding channel are set to 1, that channel is transfer-enabled. If this bit is cleared during a data transfer, transfers on all channels are suspended.</p> <p>0: Disable operation on all channels</p> <p>1: Enable operation on all channels</p> <p>Even when the DME bit is set, when the TE bit of the CHCR is 1, or its DE bit is 0, transfer is disabled when NMI of the DMAOR = 1 or when AE = 1.</p> |

Note: * Only 0 can be written to clear the flag.

10.4 Operation

When there is a DMA transfer request, the DMAC starts the transfer according to the predetermined channel priority order; when the transfer end conditions are satisfied, it ends the transfer. Transfers can be requested in three modes: auto-request, external request, and on-chip peripheral module request. Transfer can be in either the single address mode or the dual address mode, and dual address mode can be either direct or indirect address transfer mode. The bus mode can be either burst or cycle steal.

10.4.1 DMA Transfer Flow

After the DMA source address registers (SAR), DMA destination address registers (DAR), DMA transfer count register (DMATCR), DMA channel control registers (CHCR), and DMA operation register (DMAOR) are set to the desired transfer conditions, the DMAC transfers data according to the following procedure:

1. The DMAC checks to see if transfer is enabled (DE = 1, DME = 1, TE = 0, NMIF = 0, AE = 0).
2. When a transfer request comes and transfer has been enabled, the DMAC transfers 1 transfer unit of data (determined by TS0 and TS1 setting). For an auto-request, the transfer begins automatically when the DE bit and DME bit are set to 1. The DMATCR value will be decremented by 1 upon each transfer. The actual transfer flows vary by address mode and bus mode.
3. When the specified number of transfers have been completed (when DMATCR reaches 0), the transfer ends normally. If the IE bit of the CHCR is set to 1 at this time, a DEI interrupt is sent to the CPU.
4. When an address error occurs in the DMAC or an NMI interrupt is generated, the transfer is aborted. Transfers are also aborted when the DE bit of the CHCR or the DME bit of the DMAOR are changed to 0.

Figure 10.2 is a flowchart of this procedure.

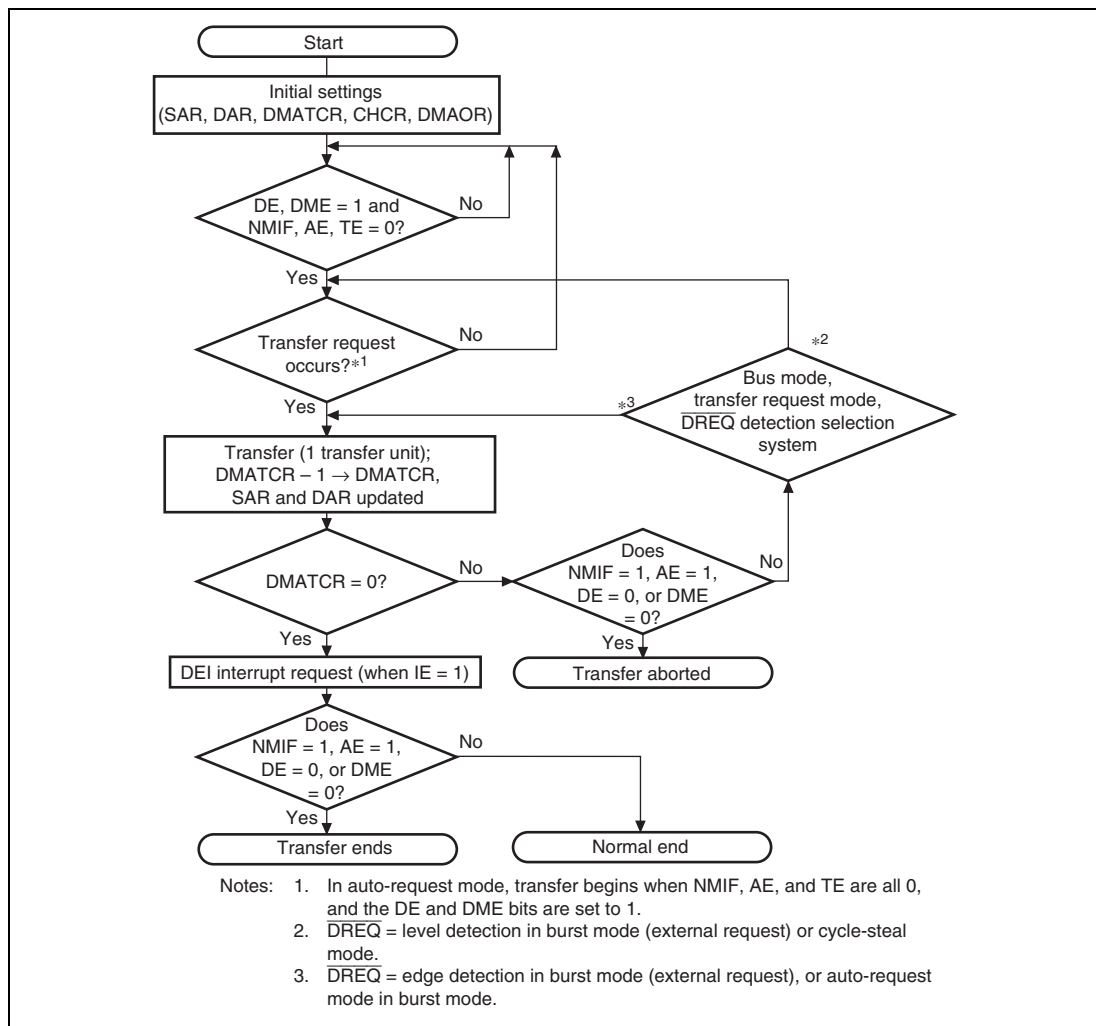

Figure 10.2 DMAC Transfer Flowchart

10.4.2 DMA Transfer Requests

DMA transfer requests are usually generated in either the data transfer source or destination, but they can also be generated by devices and on-chip peripheral modules that are neither the source nor the destination. Transfers can be requested in three modes: auto-request, external request, and on-chip peripheral module request. The request mode is selected in the RS3 to RS0 bits of the DMA channel control registers_0 to 3 (CHCR_0 to CHCR_3).

Auto-Request Mode: When there is no transfer request signal from an external source, as in a memory-to-memory transfer or a transfer between memory and an on-chip peripheral module unable to request a transfer, the auto-request mode allows the DMAC to automatically generate a transfer request signal internally. When the DE bits of CHCR_0 to CHCR_3 and the DME bit of the DMAOR are set to 1, the transfer begins (so long as the TE bits of CHCR_0 to CHCR_3 and the NMIF and AE bits of DMAOR are all 0).

External Request Mode: In this mode a transfer is performed at the request signal ($\overline{\text{DREQ}}$) of an external device. Choose one of the modes shown in table 10.2 according to the application system. When this mode is selected, if the DMA transfer is enabled (DE = 1, DME = 1, TE = 0, NMIF = 0, AE = 0), a transfer is performed upon a request at the $\overline{\text{DREQ}}$ input. Choose to detect $\overline{\text{DREQ}}$ by either the falling edge or low level of the signal input with the DS bit of CHCR_0 to CHCR_3 (DS = 0 is level detection, DS = 1 is edge detection). The source of the transfer request does not have to be the data transfer source or destination.

Table 10.2 Selecting External Request Modes with RS Bits

| RS3 | RS2 | RS1 | RS0 | Address Mode | Source | Destination |
|-----|-----|-----|-----|---------------------|--|--|
| 0 | 0 | 0 | 0 | Dual address mode | Any* | Any* |
| 0 | 0 | 1 | 0 | Single address mode | External memory or memory-mapped external device | External device with DACK |
| 0 | 0 | 1 | 1 | Single address mode | External device with DACK | External memory or memory-mapped external device |

Note: * External memory, memory-mapped external device, on-chip memory, and on-chip peripheral module (excluding DMAC, DTC, BSC, UBC).

On-Chip Peripheral Module Request Mode: In this mode a transfer is performed at the transfer request signal (interrupt request signal) of an on-chip peripheral module. As indicated in table 10.3, there are ten transfer request signals: five from the multifunction timer pulse unit (MTU), which are compare match or input capture interrupts; the receive data full interrupts (RXI) and transmit data empty interrupts (TXI) of the two serial communication interfaces (SCI); and the A/D conversion end interrupt (ADI1) of the A/D converter. When DMA transfers are enabled (DE = 1, DME = 1, TE = 0, NMIF = 0, AE = 0), a transfer is performed upon the input of a transfer request signal.

The transfer request source need not be the data transfer source or transfer destination. However, when the transfer request is set by RXI (transfer request because SCI's receive data is full), the transfer source must be the SCI's receive data register (RDR). When the transfer request is set by TXI (transfer request because SCI's transmit data is empty), the transfer destination must be the SCI's transmit data register (TDR). Also, if the transfer request is set to the A/D converter, the data transfer destination must be the A/D converter register.

Table 10.3 Selecting On-Chip Peripheral Module Request Modes with RS Bits

| RS3 | RS2 | RS1 | RS0 | DMAC Transfer Request Source | DMA Transfer Request Signal | Source | Destination | Bus Mode |
|-----|-----|-----|-----|------------------------------|-----------------------------|--------|-------------|-------------------|
| 0 | 1 | 1 | 0 | MTU | TGIA_0 | Any* | Any* | Burst/cycle steal |
| 0 | 1 | 1 | 1 | MTU | TGIA_1 | Any* | Any* | Burst/cycle steal |
| 1 | 0 | 0 | 0 | MTU | TGIA_2 | Any* | Any* | Burst/cycle steal |
| 1 | 0 | 0 | 1 | MTU | TGIA_3 | Any* | Any* | Burst/cycle steal |
| 1 | 0 | 1 | 0 | MTU | TGIA_4 | Any* | Any* | Burst/cycle steal |
| 1 | 0 | 1 | 1 | A/D1 | ADI1 | ADDR1 | Any* | Burst/cycle steal |
| 1 | 1 | 0 | 0 | SCI0 transmit block | TXI_0 | Any* | TDR0 | Burst/cycle steal |
| 1 | 1 | 0 | 1 | SCI0 receiver block | RXI_0 | RDR0 | Any* | Burst/cycle steal |
| 1 | 1 | 1 | 0 | SCI1 transmit block | TXI_1 | Any* | TDR1 | Burst/cycle steal |
| 1 | 1 | 1 | 1 | SCI1 receiver block | RXI_1 | RDR1 | Any* | Burst/cycle steal |

Notes: MTU: Multifunction timer pulse unit.

SCI0, SCI1: Serial communications interface channels 0 and 1.

ADDR1: A/D converter's A/D register.

TDR_0, TDR_1: SCI_0 and SCI_1 transmit data registers.

RDR_0, RDR_1: SCI_0 and SCI_1 receive data registers.

* External memory, memory-mapped external device, on-chip memory, and on-chip peripheral module (excluding DMAC, DTC, BSC, and UBC).

In order to output a transfer request from an on-chip peripheral module, set the relevant interrupt enable bit for each module, and output an interrupt signal.

When an on-chip peripheral module's interrupt request signal is used as a DMA transfer request signal, interrupts for the CPU are not generated.

When a DMA transfer is conducted corresponding with one of the transfer request signals in table 10.3, it is automatically discontinued. In cycle steal mode this occurs in the first transfer, and in burst mode in the last transfer.

10.4.3 Channel Priority

When the DMAC receives simultaneous transfer requests on two or more channels, it selects a channel according to a predetermined priority order, either in a fixed mode or in round robin mode. These modes are selected by priority bits PR1 and PR0 in the DMA operation register (DMAOR).

Fixed Mode: In this mode, the priority levels among the channels remain fixed.

The following priority orders are available for fixed mode:

- CH0 > CH1 > CH2 > CH3
- CH0 > CH2 > CH3 > CH1
- CH2 > CH0 > CH1 > CH3

These are selected by settings of the PR1 and PR0 bits of the DMA operation register (DMAOR).

Round Robin Mode: In round robin mode, each time the transfer of one transfer unit (byte, word or long word) ends on a given channel, that channel receives the lowest priority level (figure 10.3 (1)). The priority level in round robin mode immediately after a reset is CH0 > CH1 > CH2 > CH3.

Transfer on channel 0**Transfer on channel 1****Transfer on channel 2****Transfer on channel 3****Figure 10.3 (1) Round Robin Mode**

Figure 10.3 (2) shows the changes in priority levels when transfer requests are issued simultaneously for channels 0 and 3, and channel 1 receives a transfer request during a transfer on channel 0. The DMAC operates in the following manner under these circumstances:

1. Transfer requests are issued simultaneously for channels 0 and 3.
2. Since channel 0 has a higher priority level than channel 3, the channel 0 transfer is conducted first (channel 3 is on transfer standby).
3. A transfer request is issued for channel 1 during a transfer on channel 0 (channels 1 and 3 are on transfer standby).
4. At the end of the channel 0 transfer, channel 0 shifts to the lowest priority level.
5. At this point, channel 1 has a higher priority level than channel 3, so the channel 1 transfer comes first (channel 3 is on transfer standby).
6. When the channel 1 transfer ends, channel 1 shifts to the lowest priority level.
7. Channel 3 transfer begins.
8. When the channel 3 transfer ends, channel 3 and channel 2 priority levels are lowered, giving channel 3 the lowest priority.

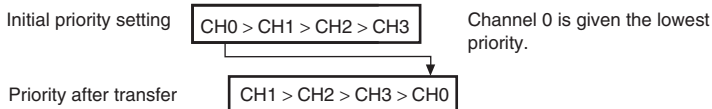
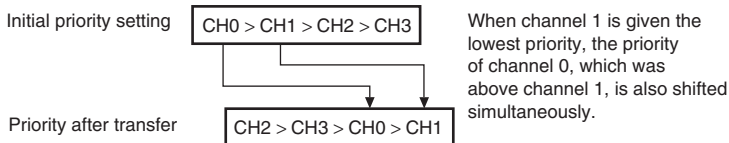
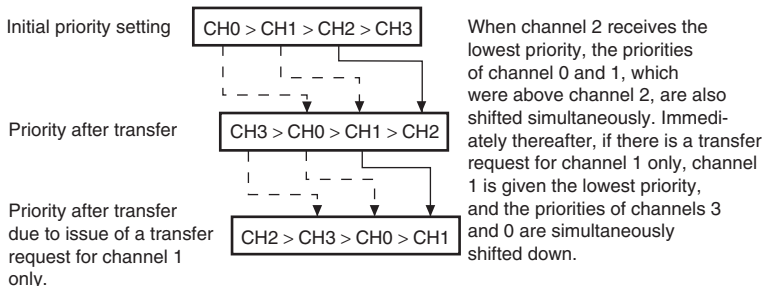
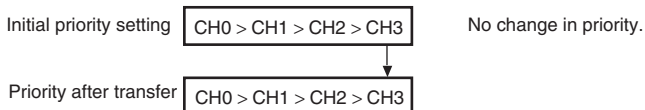
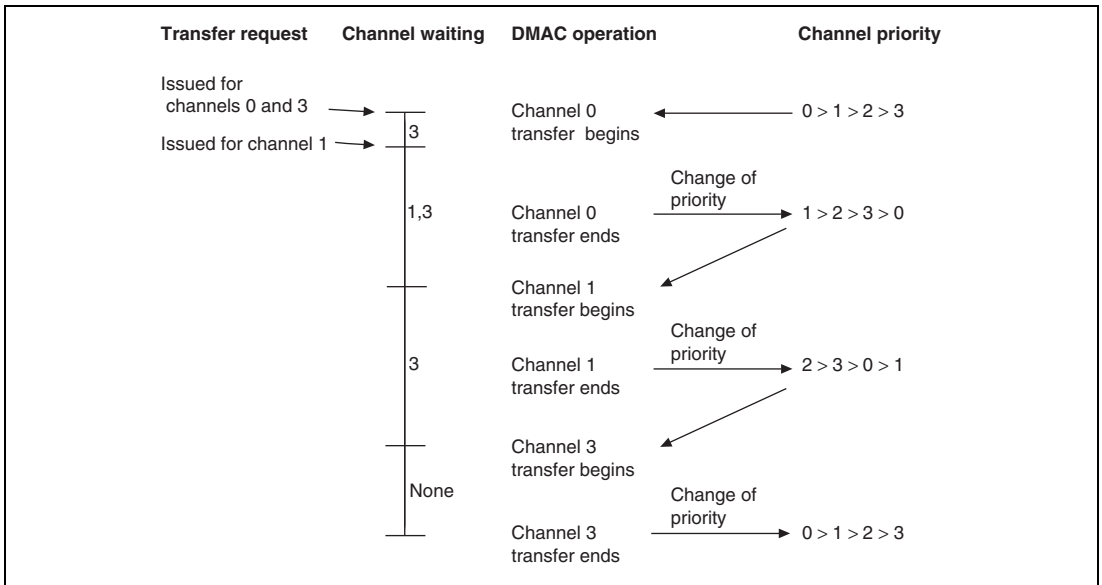

Figure 10.3 (2) Example of Changes in Priority in Round Robin Mode

10.4.4 DMA Transfer Types

The DMAC supports the transfers shown in table 10.4. It can operate in the single address mode, in which either the transfer source or destination is accessed using an acknowledge signal, or dual access mode, in which both the transfer source and destination addresses are output. The dual access mode consists of a direct address mode, in which the output address value is the object of a direct data transfer, and an indirect address mode, in which the output address value is not the object of the data transfer, but the value stored at the output address becomes the transfer object address. The actual transfer operation timing varies with the bus mode. The DMAC has two bus modes: cycle-steal mode and burst mode.

Table 10.4 Supported DMA Transfers

| Source | Destination | | | | |
|-------------------------------|---------------------------|-----------------|-------------------------------|----------------|---------------------------|
| | External Device with DACK | External Memory | Memory-Mapped External Device | On-Chip Memory | On-Chip Peripheral Module |
| External device with DACK | Not available | Single | Single | Not available | Not available |
| External memory | Single | Dual | Dual | Dual | Dual |
| Memory-mapped external device | Single | Dual | Dual | Dual | Dual |
| On-chip memory | Not available | Dual | Dual | Dual | Dual |
| On-chip peripheral module | Not available | Dual | Dual | Dual | Dual |

Note: Dual address mode includes both direct address mode and indirect address mode.

Address Modes:

- Single Address Mode

In the single address mode, both the transfer source and destination are external; one is accessed by a DACK signal while the other is accessed by an address. In this mode, the DMAC performs the DMA transfer in 1 bus cycle by simultaneously outputting a transfer request acknowledge DACK signal to one external device to access it while outputting an address to the other end of the transfer. Figure 10.4 shows an example of a transfer between an external memory and an external device with DACK in which the external device outputs data to the data bus while that data is written in external memory in the same bus cycle.

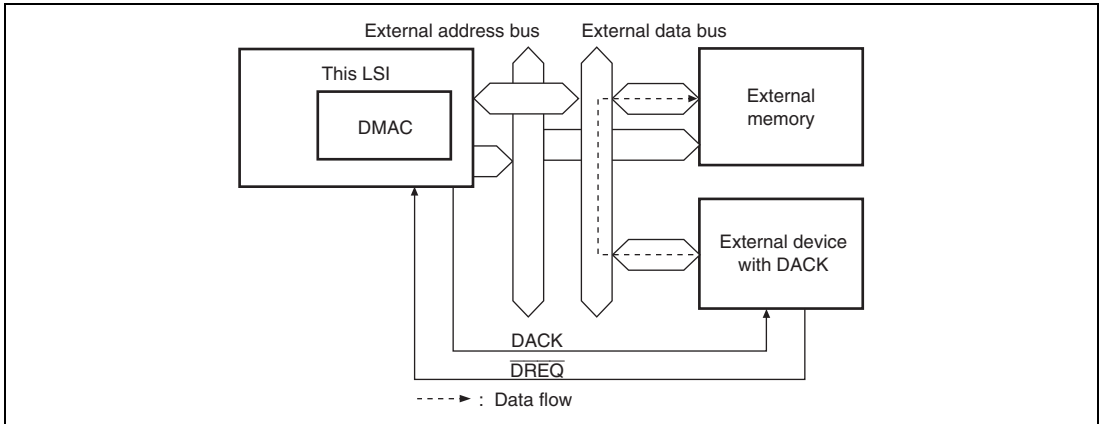

Figure 10.4 Data Flow in Single Address Mode

Two types of transfers are possible in the single address mode: (a) transfers between external devices with DACK and memory-mapped external devices, and (b) transfers between external devices with DACK and external memory. The only transfer requests for either of these is the external request ($\overline{\text{DREQ}}$). Figure 10.5 shows the DMA transfer timing for the single address mode.

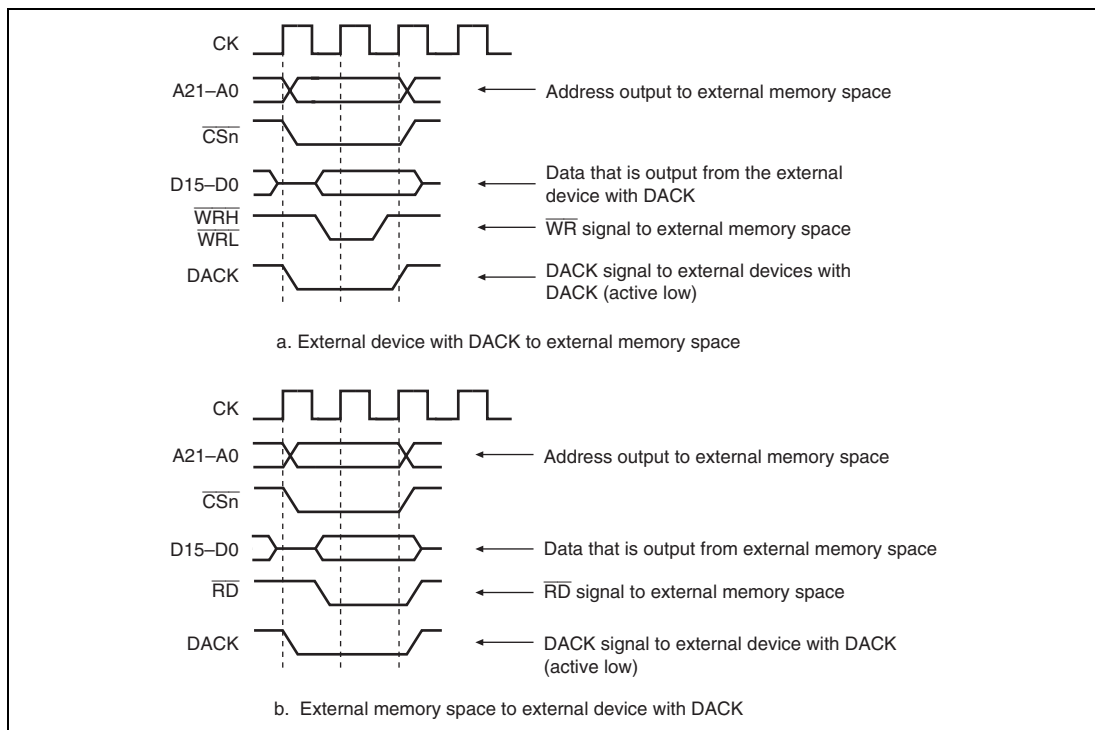

Figure 10.5 Example of DMA Transfer Timing in Single Address Mode

Dual Address Mode:

Dual address mode is used for access of both the transfer source and destination by address. Transfer source and destination can be accessed either internally or externally. Dual address mode is subdivided into two other modes: direct address transfer mode and indirect address transfer mode.

- Direct Address Transfer Mode

Data is read from the transfer source during the data read cycle, and written to the transfer destination during the write cycle, so transfer is conducted in two bus cycles. At this time, the transfer data is temporarily stored in the DMAC. With the kind of external memory transfer shown in figure 10.6, data is read from one of the memories by the DMAC during a read cycle, then written to the other external memory during the subsequent write cycle. Figure 10.7 shows the timing for this operation.

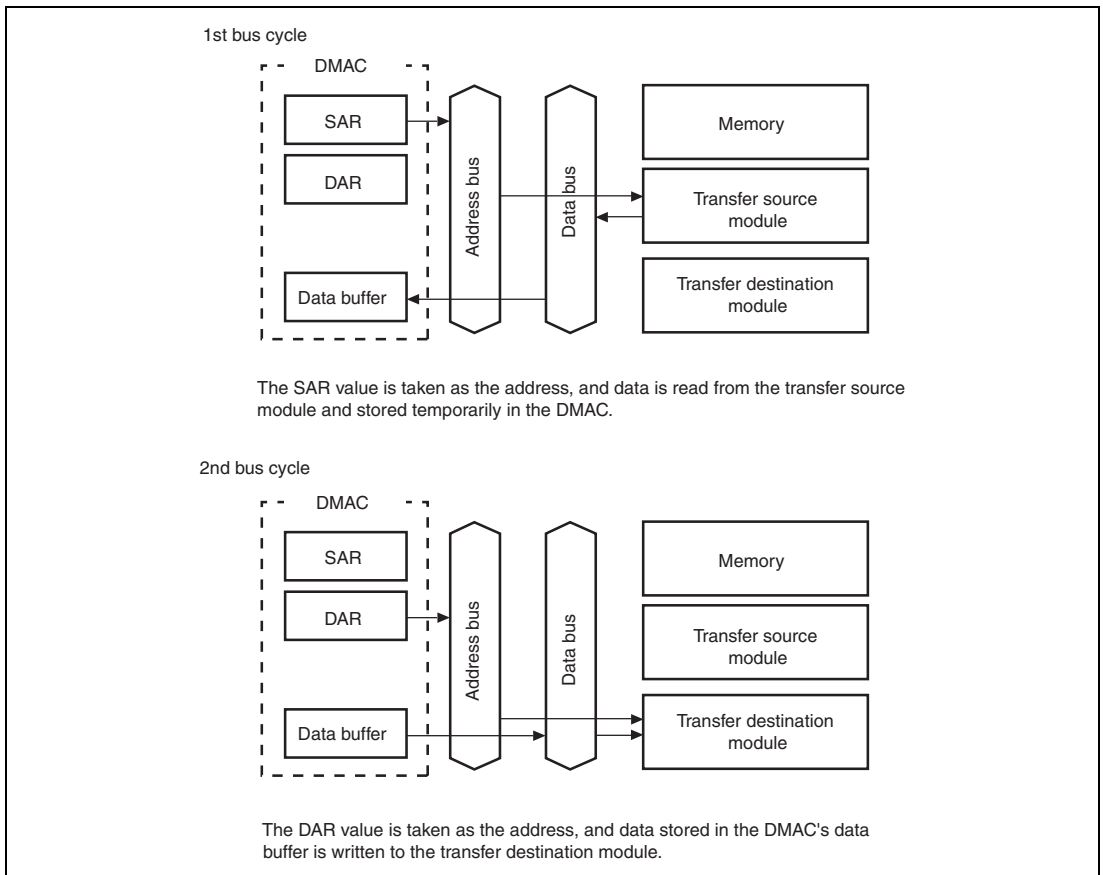

Figure 10.6 Direct Address Operation during Dual Address Mode

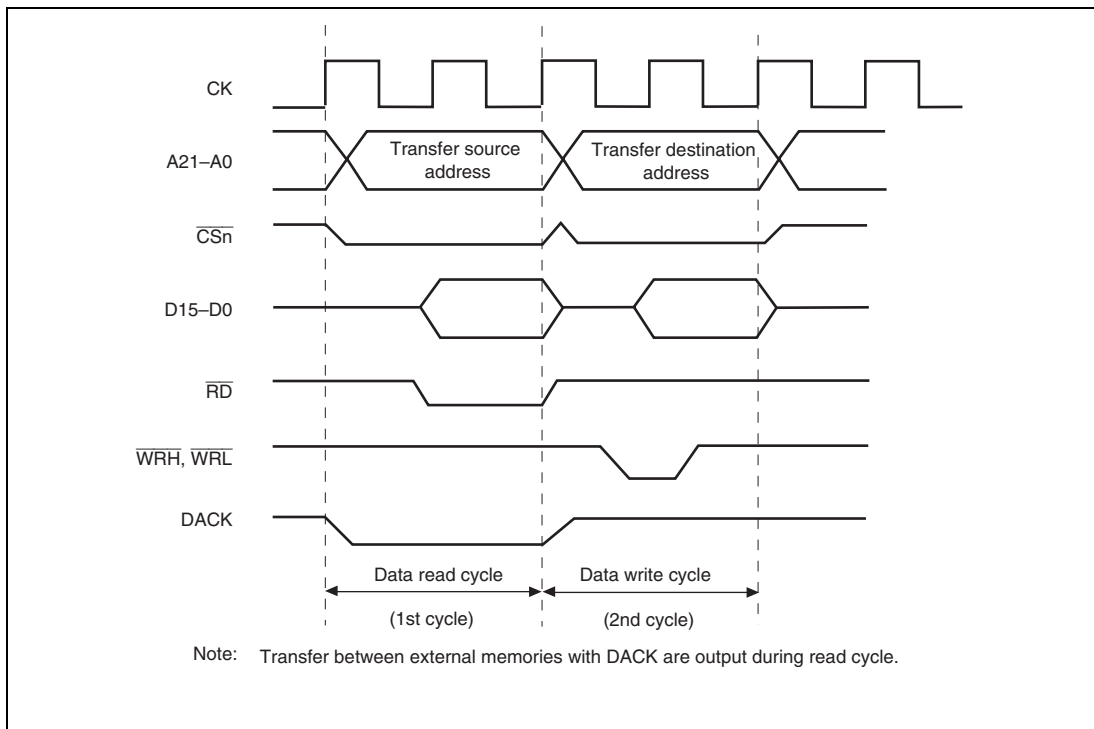

Figure 10.7 Example of Direct Address Transfer Timing in Dual Address Mode

- Indirect Address Transfer Mode

In this mode the memory address storing the data you actually want to transfer is specified in DMAC internal transfer source address register (SAR3). Therefore, in indirect address transfer mode, the DMAC internal transfer source address register value is read first. This value is stored once in the DMAC. Next, the read value is output as the address, and the value stored at that address is again stored in the DMAC. Finally, the subsequent read value is written to the address specified by the transfer destination address register, ending one cycle of DMA transfer.

In indirect address mode (figure 10.8), transfer destination, transfer source, and indirect address storage destination are all 16-bit external memory locations, and transfer in this example is conducted in 16-bit or 8-bit units. Timing for this transfer example is shown in figure 10.9.

In indirect address mode, one NOP cycle (figure 10.9) is required until the data read as the indirect address is output to the address bus. When transfer data is 32-bit, the third and fourth bus cycles each need to be doubled, giving a required total of six bus cycles and one NOP cycle for the whole operation.

1st, 2nd bus cycles

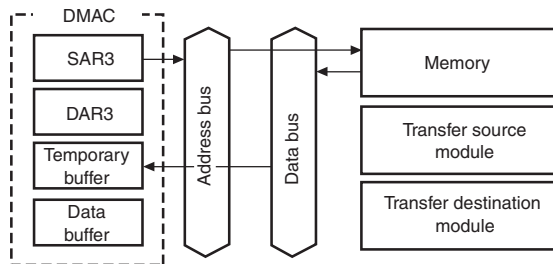

The SAR3 value is taken as the address, memory data is read, and the value is stored in the temporary buffer. Since the value read at this time is used as the address, it must be 32 bits. When external connection data bus is 16 bits, two bus cycles are required.

3rd bus cycle

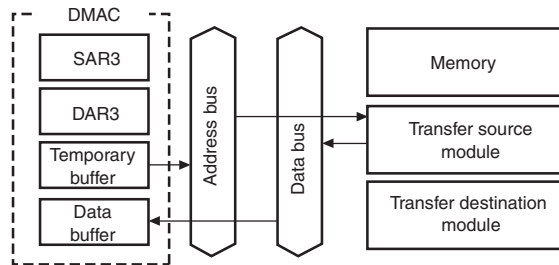

The value in the temporary buffer is taken as the address, and data is read from the transfer source module to the data buffer.

4th bus cycle

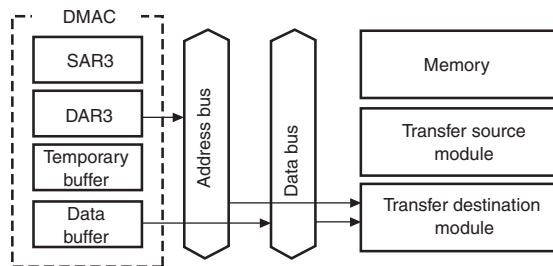

The DAR3 value is taken as the address, and the value in the data buffer is written to the transfer destination module.

Note: Memory, transfer source, and transfer destination modules are shown here. In practice, connection can be made anywhere if there is address space.

**Figure 10.8 Dual Address Mode and Indirect Address Operation
(When External Memory Space Is 16 Bits)**

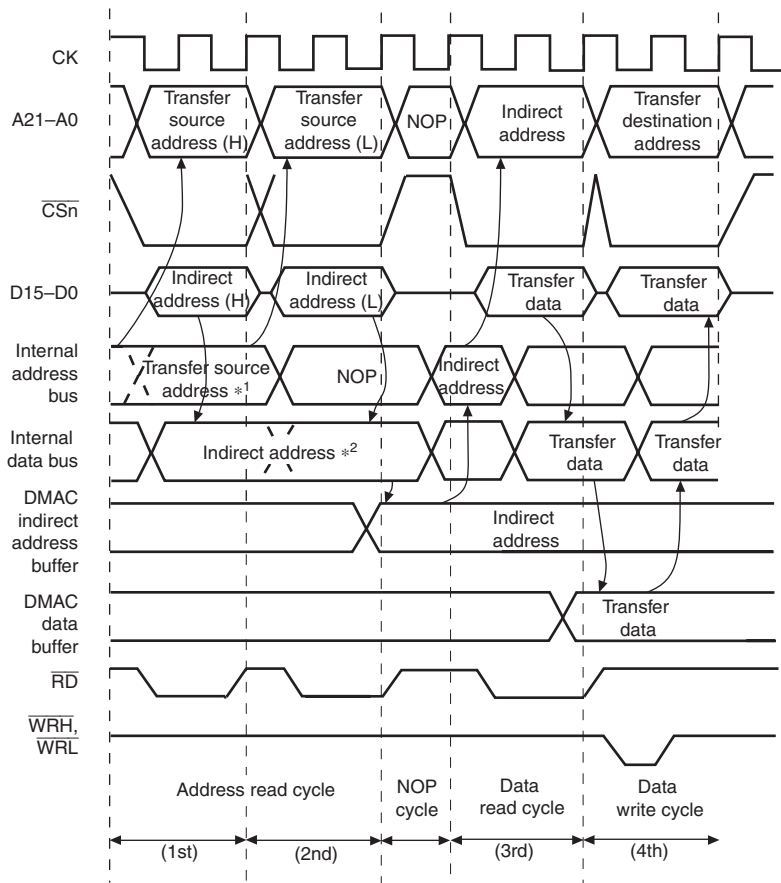

- Notes:
1. The internal address bus is controlled by the port and does not change.
 2. DMAC does not fetch value until 32-bit data is read from the internal data bus.

Figure 10.9 Dual Address Mode and Indirect Address Transfer Timing Example (External Memory Space to External Memory Space, 16-Bit Width)

Figure 10.10 shows an example of timing in indirect address mode when transfer source and indirect address storage locations are in internal memory, the transfer destination is an on-chip peripheral module with 2-cycle access space, and transfer data is 8-bit.

Since the indirect address storage destination and the transfer source are in internal memory, these can be accessed in one cycle. The transfer destination is 2-cycle access space, so two data write cycles are required. One NOP cycle is required until the data read as the indirect address is output to the address bus.

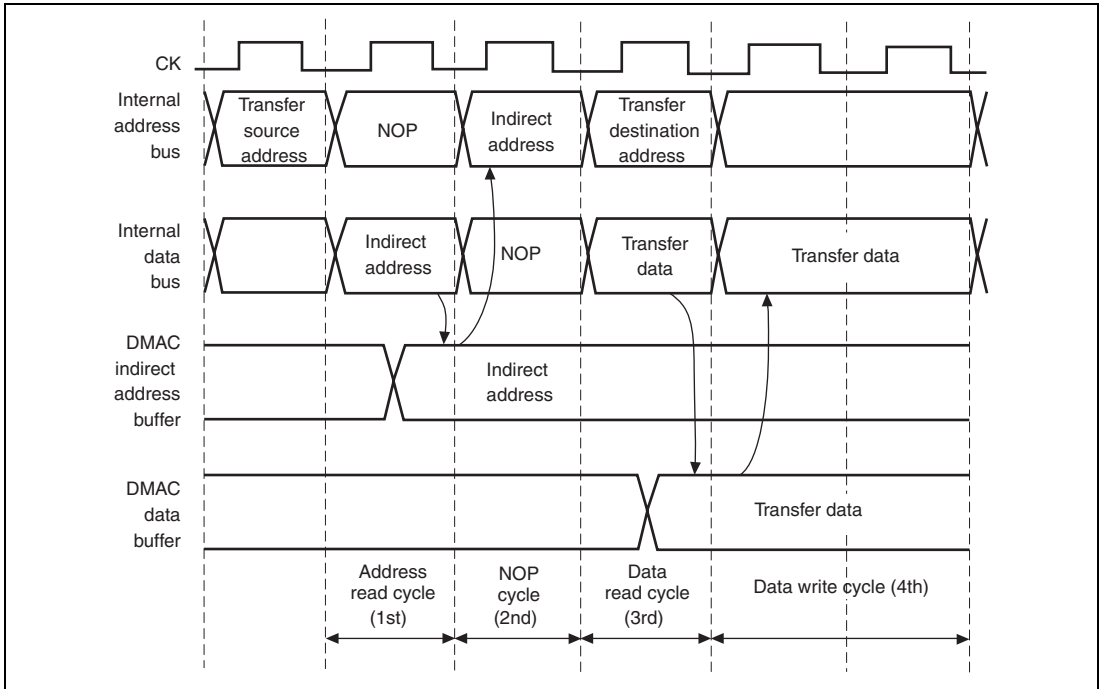

Figure 10.10 Dual Address Mode and Indirect Address Transfer Timing Example (On-chip Memory Space to On-chip Memory Space)

Bus Modes:

Select the appropriate bus mode in the TM bits of CHCR_0 to CHCR_3. There are two bus modes: cycle steal and burst.

- **Cycle-Steal Mode**

In the cycle steal mode, the bus mastership is given to another bus master after each one-transfer-unit (byte, word, or longword) DMAC transfer. When the next transfer request occurs, the bus mastership are obtained from the other bus master and a transfer is performed for one transfer unit. When that transfer ends, the bus mastership is passed to the other bus master. This is repeated until the transfer end conditions are satisfied.

The cycle steal mode can be used with all categories of transfer destination, transfer source and transfer request. Figure 10.11 shows an example of DMA transfer timing in the cycle steal mode. Transfer conditions are dual address mode and $\overline{\text{DREQ}}$ level detection.

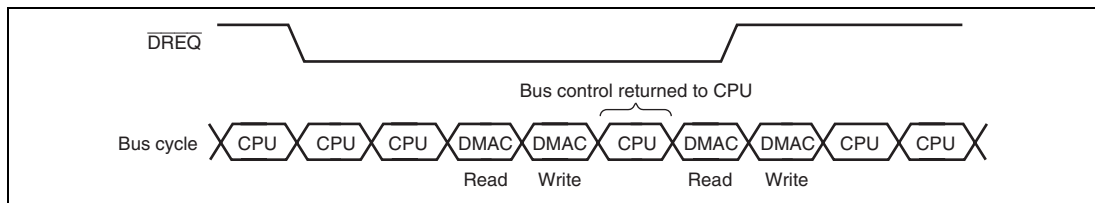

Figure 10.11 DMA Transfer Example in Cycle-Steal Mode

- **Burst Mode**

Once the bus mastership is obtained, the transfer is performed continuously until the transfer end condition is satisfied. In the external request mode with low level detection of the $\overline{\text{DREQ}}$ pin, however, when the $\overline{\text{DREQ}}$ pin is driven high, the bus passes to the other bus master after the bus cycle of the DMAC that currently has an acknowledged request ends, even if the transfer end conditions have not been satisfied.

Figure 10.12 shows an example of DMA transfer timing in the burst mode. Transfer conditions are single address mode and $\overline{\text{DREQ}}$ level detection.

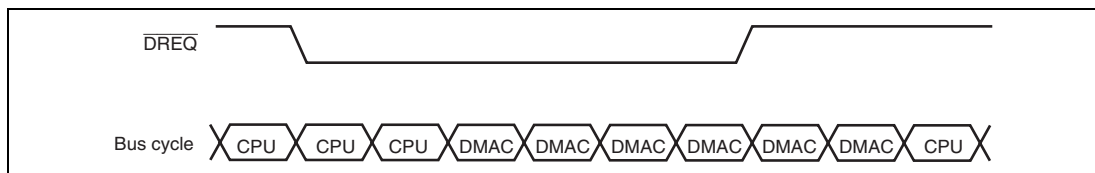

Figure 10.12 DMA Transfer Example in Burst Mode

Relationship between Request Modes and Bus Modes by DMA Transfer Category:

Table 10.5 shows the relationship between request modes and bus modes by DMA transfer category.

Table 10.5 Relationship of Request Modes and Bus Modes by DMA Transfer Category

| Address Mode | Transfer Category | Request Mode | Bus Mode | Transfer Size (Bits) | Usable Channels |
|---|---|-------------------|-----------------------|-----------------------|----------------------|
| Single | External device with DACK and external memory | External | B/C | 8/16/32 | 0, 1 |
| | External device with DACK and memory-mapped external device | External | B/C | 8/16/32 | 0, 1 |
| Dual | External memory and external memory | Any* ¹ | B/C | 8/16/32 | 0 to 3* ⁵ |
| | External memory and memory-mapped external device | Any* ¹ | B/C | 8/16/32 | 0 to 3* ⁵ |
| | Memory-mapped external device and memory-mapped external device | Any* ¹ | B/C | 8/16/32 | 0 to 3* ⁵ |
| | External memory and on-chip memory | Any* ¹ | B/C | 8/16/32 | 0 to 3* ⁵ |
| | External memory and on-chip peripheral module | Any* ² | B/C* ³ | 8/16/32* ⁴ | 0 to 3* ⁵ |
| | Memory-mapped external device and on-chip memory | Any* ¹ | B/C | 8/16/32 | 0 to 3* ⁵ |
| | Memory-mapped external device and on-chip peripheral module | Any* ² | B/C* ³ | 8/16/32* ⁴ | 0 to 3* ⁵ |
| | On-chip memory and on-chip memory | Any* ¹ | B/C | 8/16/32 | 0 to 3* ⁵ |
| | On-chip memory and on-chip peripheral module | Any* ² | B/C* ³ | 8/16/32* ⁴ | 0 to 3* ⁵ |
| On-chip peripheral module and on-chip peripheral module | Any* ² | B/C* ³ | 8/16/32* ⁴ | 0 to 3* ⁵ | |

B: Burst

C: Cycle steal

- Notes:
1. External request, auto-request or on-chip peripheral module request enabled. However, in the case of on-chip peripheral module request, it is not possible to specify the SCI or A/D converter for the transfer request source.
 2. External request, auto-request or on-chip peripheral module request possible. However, if transfer request source is also the SCI or A/D converter, the transfer source or transfer destination must be the SCI or A/D converter.
 3. When the transfer request source is the SCI, only cycle steal mode is possible.
 4. Access size permitted by register of on-chip peripheral module that is the transfer source or transfer destination.
 5. When the transfer request is an external request, channels 0 and 1 only can be used.

Bus Mode and Channel Priority:

When a given channel is transferring in burst mode, and a transfer request is issued to channel 0, which has a higher priority ranking, transfer on channel 0 begins immediately. If the priority level setting is fixed mode (CH0 > CH1), channel 1 transfer is continued after transfer on channel 0 are completely ended, whether the channel 0 setting is cycle steal mode or burst mode.

When the priority level setting is for round robin mode, transfer on channel 1 begins after transfer of one transfer unit on channel 0, whether channel 0 is set to cycle steal mode or burst mode. Thereafter, bus mastership alternates in the order: channel 1 → channel 0 → channel 1 → channel 0. Whether the priority level setting is for fixed mode or round robin mode, since channel 1 is set to burst mode, the bus mastership is not given to the CPU. An example of round robin mode is shown in figure 10.13.

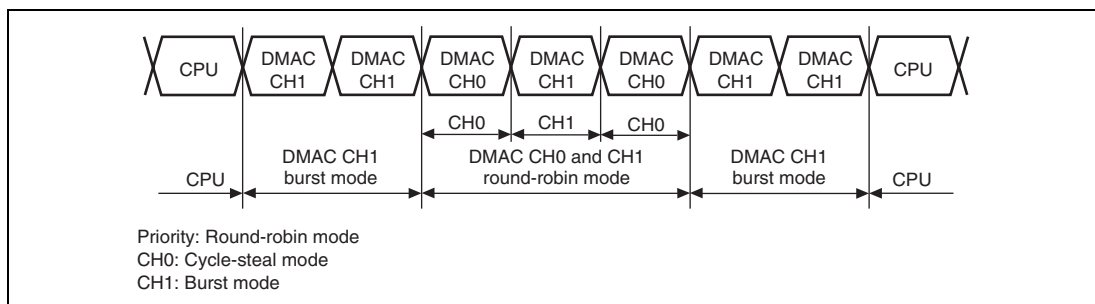

Figure 10.13 Bus Handling when Multiple Channels Are Operating

10.4.5 Number of Bus Cycle States and $\overline{\text{DREQ}}$ Pin Sample Timing

Number of States in Bus Cycle: The number of states in the bus cycle when the DMAC is the bus master is controlled by the bus state controller (BSC) just as it is when the CPU is the bus master. For details, see section 9, Bus State Controller (BSC).

$\overline{\text{DREQ}}$ Pin Sampling Timing and DRAK Signal: In external request mode, the $\overline{\text{DREQ}}$ pin is sampled by either falling edge or low-level detection. When a $\overline{\text{DREQ}}$ input is detected, a DMAC bus cycle is issued and DMA transfer effected, at the earliest, after three states. However, in burst mode when single address operation is specified, a dummy cycle is inserted for the first bus cycle. In this case, the actual data transfer starts from the second bus cycle. Data is transferred continuously from the second bus cycle. The dummy cycle is not counted in the number of transfer cycles, so there is no need to recognize the dummy cycle when setting the TCR.

$\overline{\text{DREQ}}$ sampling from the second time begins from the start of the transfer one bus cycle prior to the DMAC transfer generated by the previous sampling.

DRAK is output once for the first $\overline{\text{DREQ}}$ sampling, irrespective of transfer mode or $\overline{\text{DREQ}}$ detection method. In burst mode, using edge detection, $\overline{\text{DREQ}}$ is sampled for the first cycle only, so DRAK is also output for the first cycle only. Therefore, the $\overline{\text{DREQ}}$ signal negate timing can be ascertained, and this facilitates handshake operations of transfer requests with the DMAC.

Cycle Steal Mode Operations: In cycle steal mode, $\overline{\text{DREQ}}$ sampling timing is the same irrespective of dual or single address mode, or whether edge or low-level $\overline{\text{DREQ}}$ detection is used.

For example, DMAC transfer begins (figure 10.14), at the earliest, three cycles from the first sampling timing. The second sampling begins at the start of the transfer one bus cycle prior to the start of the DMAC transfer initiated by the first sampling (i.e., from the start of the CPU(3) transfer). At this point, if $\overline{\text{DREQ}}$ detection has not occurred, sampling is executed every cycle thereafter.

As in figure 10.15, whatever cycle the CPU transfer cycle is, the next sampling begins from the start of the transfer one bus cycle before the DMAC transfer begins.

Figure 10.14 shows an example of output during DACK read and figure 10.15 an example of output during DACK write.

Figures 10.16 and 10.17 show cycle steal mode and single address mode. In this case, transfer begins at earliest three cycles after the first $\overline{\text{DREQ}}$ sampling. The second sampling begins from the start of the transfer one bus cycle before the start of the first DMAC transfer. In single address mode, the DACK signal is output during the DMAC transfer period.

Burst Mode, Dual Address, and Level Detection: Figures 10.18 and 10.19 show the $\overline{\text{DREQ}}$ sampling timing in burst mode with dual address and level detection. $\overline{\text{DREQ}}$ sampling timing in this mode is virtually the same as that of cycle steal mode.

For example, DMAC transfer begins (figure 10.18), at the earliest, three cycles after the timing of the first sampling. The second sampling also begins from the start of the transfer one bus cycle before the start of the first DMAC transfer. In burst mode, as long as transfer requests are issued, DMAC transfer continues. Therefore, the “transfer one bus cycle before the start of the DMAC transfer” may be a DMAC transfer.

In burst mode, the DACK output period is the same as that of cycle steal mode.

Burst Mode, Single Address, and Level Detection: $\overline{\text{DREQ}}$ sampling timing in burst mode with single address and level detection is shown in figures 10.20 and 10.21.

In burst mode with single address and level detection, a dummy cycle is inserted as one bus cycle, at the earliest, three cycles after timing of the first sampling. Data during this period is undefined,

and the DACK signal is not output. Nor is the number of DMAC transfers counted. The actual DMAC transfer begins after one dummy bus cycle output.

The dummy cycle is not counted either at the start of the second sampling (transfer one bus cycle before the start of the first DMAC transfer). Therefore, the second sampling is not conducted from the bus cycle starting the dummy cycle, but from the start of the CPU(3) bus cycle.

Thereafter, as long as $\overline{\text{DREQ}}$ is continuously sampled, no dummy cycle is inserted. $\overline{\text{DREQ}}$ sampling timing during this period begins from the start of the transfer one bus cycle before the start of DMAC transfer, in the same way as with cycle steal mode.

As with the fourth sampling in figure 10.20, once DMAC transfer is interrupted, a dummy cycle is again inserted at the start as soon as DMAC transfer is resumed.

The DACK output period in burst mode is the same as in cycle steal mode.

Burst Mode, Dual Address, and Edge Detection: In burst mode with dual address and edge detection, $\overline{\text{DREQ}}$ sampling is conducted only on the first cycle.

In figure 10.22, DMAC transfer begins, at the earliest, three cycles after the timing of the first sampling. Thereafter, DMAC transfer continues until the end of the data transfer count set in the DMATCR. $\overline{\text{DREQ}}$ sampling is not conducted during this period. Therefore, DRAK is output on the first cycle only.

When DMAC transfer is resumed after being halted by an NMI or address error, be sure to reinput an edge request. The remaining transfer restarts after the first DRAK output.

The DACK output period in burst mode is the same as in cycle steal mode.

Burst Mode, Single Address, and Edge Detection: In burst mode with single address and edge detection, $\overline{\text{DREQ}}$ sampling is conducted only on the first cycle. In figure 10.23, a dummy cycle is inserted, at the earliest, three cycles after the timing for the first sampling. During this period, data is undefined, and DACK is not output. Nor is the number of DMAC transfers counted. Thereafter, DMAC transfer continues until the data transfer count set in the DMATCR has ended. $\overline{\text{DREQ}}$ sampling is not conducted during this period. Therefore, DRAK is output on the first cycle only.

When DMAC transfer is resumed after being halted by an NMI or address error, be sure to reinput an edge request. DRAK is output once, and the remaining transfer restarts after output of one dummy cycle.

The DACK output period in burst mode is the same as in cycle steal mode.

10. Direct Memory Access Controller (DMAC)

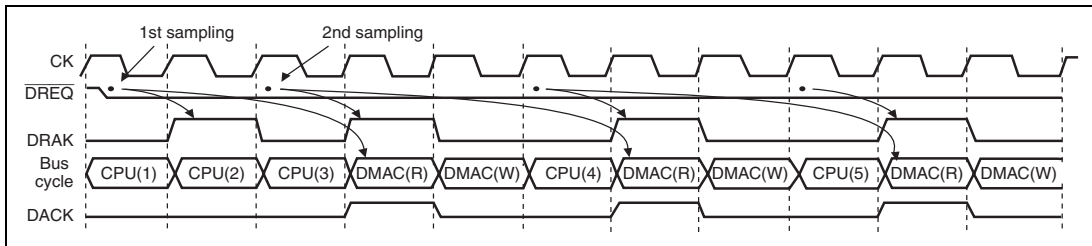

Figure 10.14 Cycle Steal, Dual Address and Level Detection (Fastest Operation)

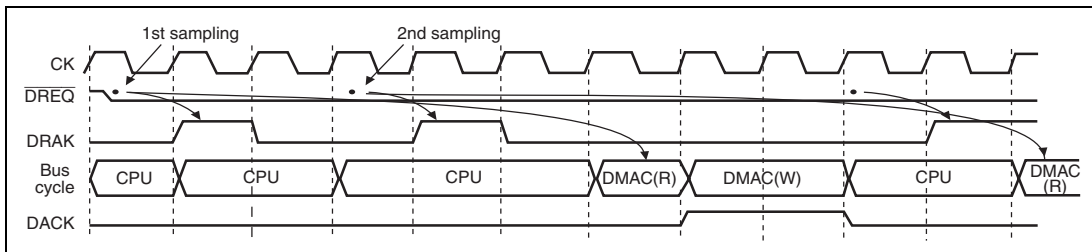

Figure 10.15 Cycle Steal, Dual Address and Level Detection (Normal Operation)

Note: With cycle-steal and dual address operation, sampling timing is the same regardless of whether $\overline{\text{DREQ}}$ detection is by level or by edge.

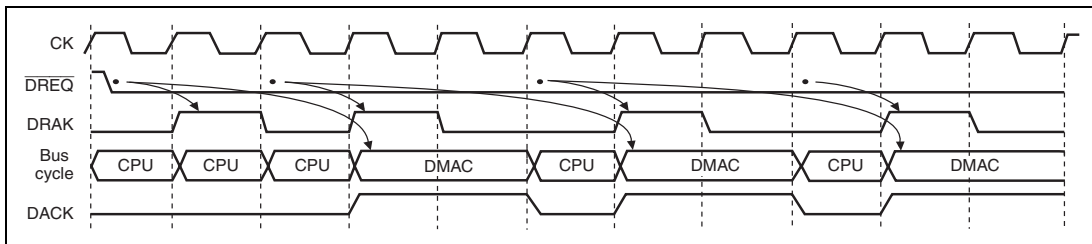

Figure 10.16 Cycle Steal, Single Address and Level Detection (Fastest Operation)

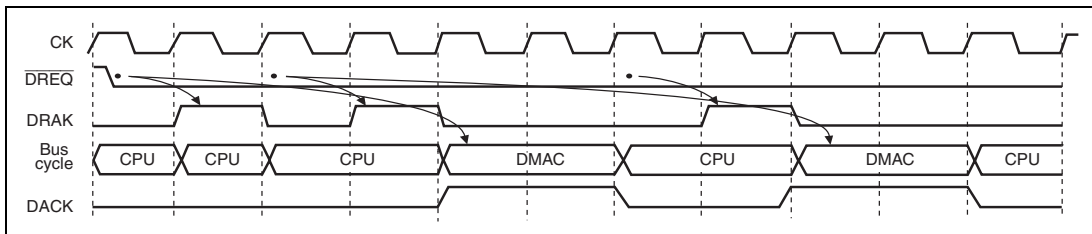

Figure 10.17 Cycle Steal, Single Address and Level Detection (Normal Operation)

Note: With cycle steal and single address operation, sampling timing is the same regardless of whether DREQ detection is by level or by edge.

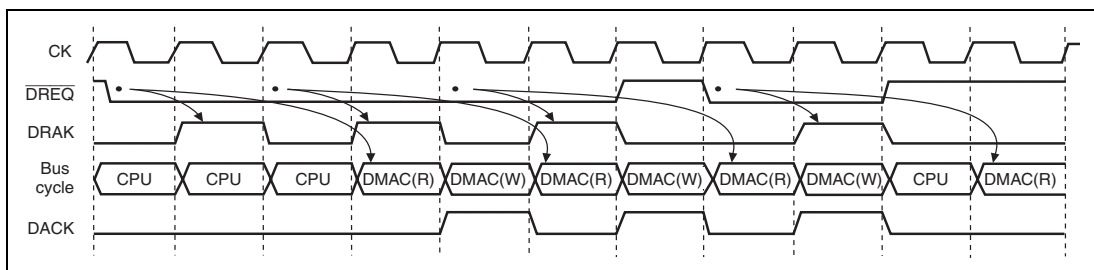

Figure 10.18 Burst Mode, Dual Address and Level Detection (Fastest Operation)

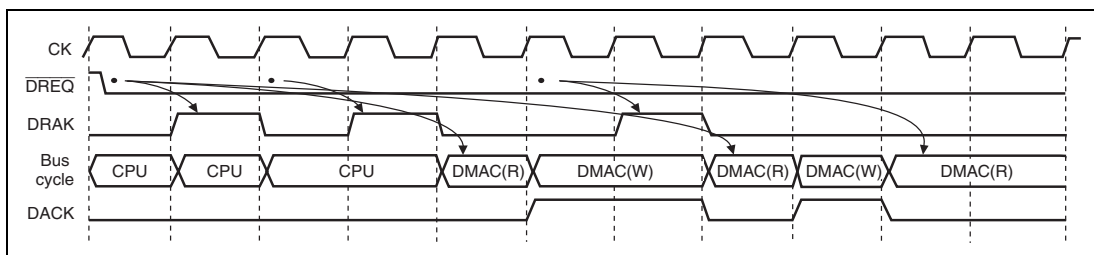

Figure 10.19 Burst Mode, Dual Address and Level Detection (Normal Operation)

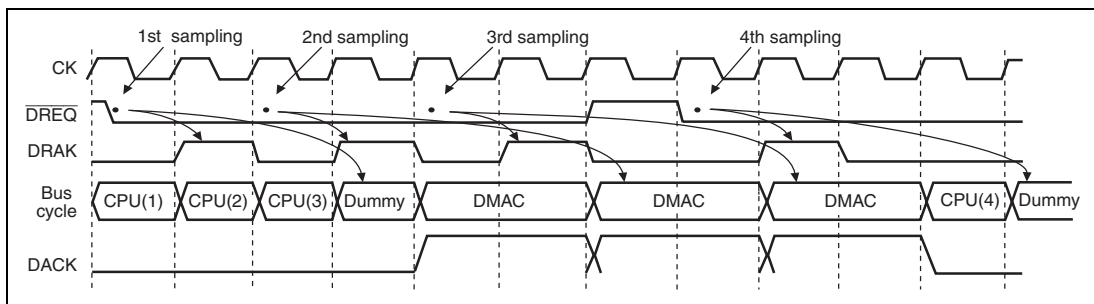

Figure 10.20 Burst Mode, Single Address and Level Detection (Fastest Operation)

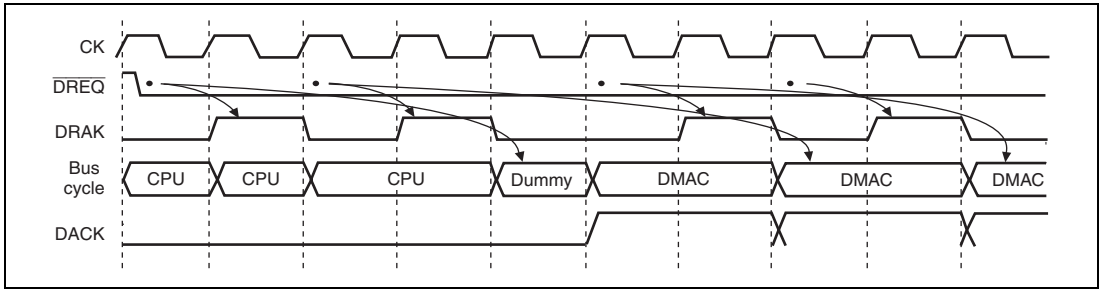

Figure 10.21 Burst Mode, Single Address and Level Detection (Normal Operation)

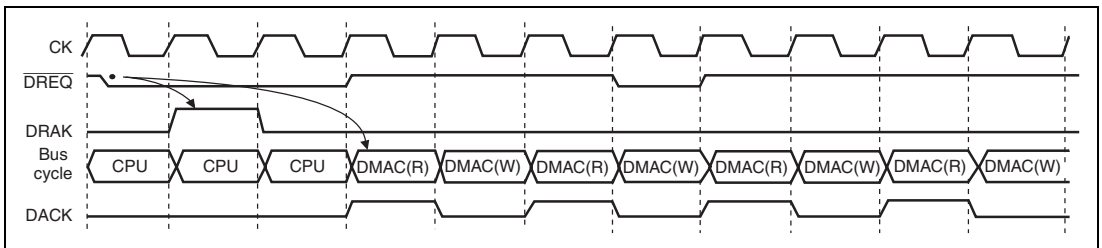

Figure 10.22 Burst Mode, Dual Address and Edge Detection

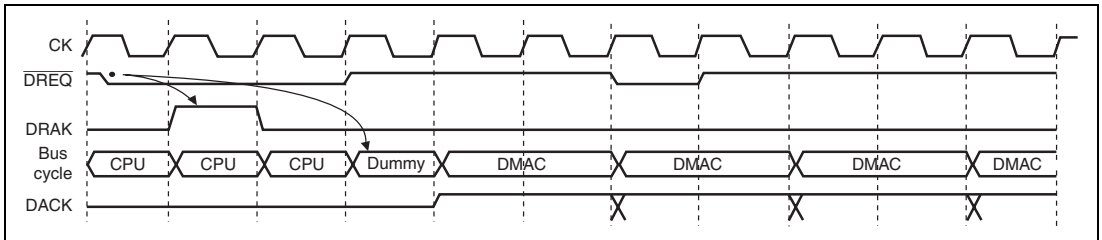

Figure 10.23 Burst Mode, Single Address and Edge Detection

10.4.6 Source Address Reload Function

Channel 2 has a source address reload function. This returns to the first value set in the source address register (SAR_2) every four transfers by setting the RO bit of CHCR_2 to 1. Figure 10.24 illustrates this operation. Figure 10.25 is a timing chart for reload ON mode, with burst mode, autorequest, 16-bit transfer data size, SAR_2 increment, and DAR_2 fixed mode.

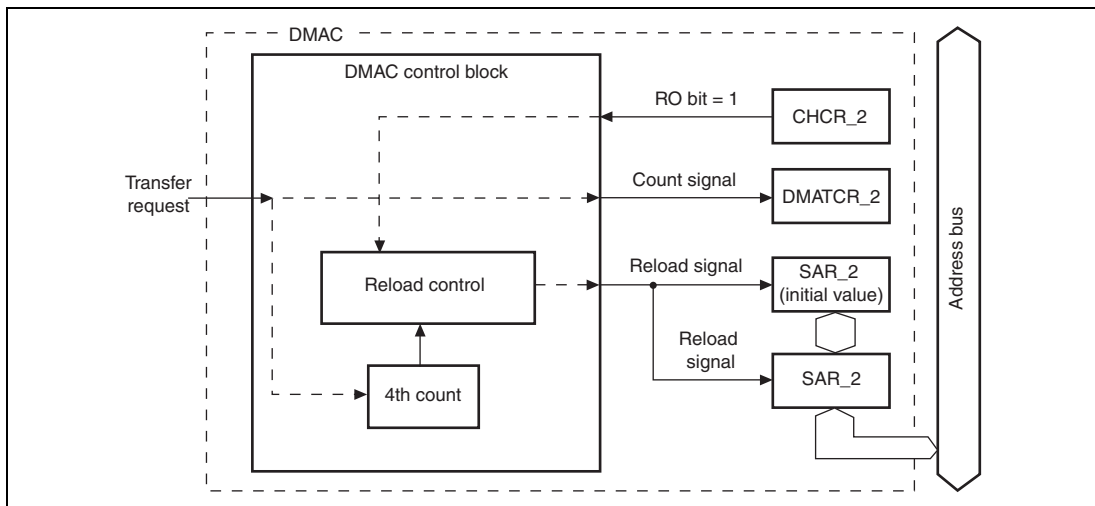

Figure 10.24 Source Address Reload Function

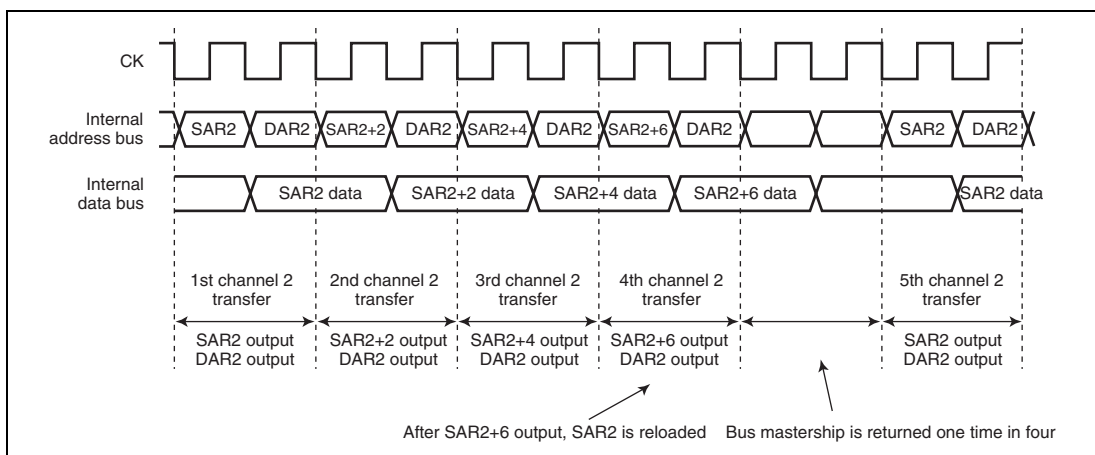

Figure 10.25 Source Address Reload Function Timing Chart

The reload function can be executed whether the transfer data size is 8, 16, or 32 bits.

DMATCR_2, which specifies the number of transfers, is decremented by 1 at the end of every single-transfer-unit transfer, regardless of whether the reload function is on or off. Therefore, when using the reload function in the on state, a multiple of 4 must be specified in DMATCR_2. Operation will not be guaranteed if any other value is set. Also, the counter which counts the occurrence of four transfers for address reloading is reset by clearing of the DME bit in DMAOR or the DE bit in CHCR_2, setting of the transfer end flag (the TE bit in CHCR_2), NMI input, and setting of the AE flag (address error generation in DMAC transfer), as well as by a reset and in software standby mode, but SAR_2, DAR_2, DMATCR_2, and other registers are not reset. Consequently, when one of these sources occurs, there is a mixture of initialized counters and uninitialized registers in the DMAC, and incorrect operation may result if a restart is executed in this state. Therefore, when one of the above sources, other than TE setting, occurs during use of the address reload function, SAR_2, DAR_2, and DMATCR_2 settings must be carried out before re-execution.

10.4.7 DMA Transfer Ending Conditions

The DMA transfer ending conditions vary for individual channels ending and for all channels ending together.

Individual Channel Ending Conditions: There are two ending conditions. A transfer ends when the value of the channel's DMA transfer count register (DMATCR) is 0, or when the DE bit of the channel's CHCR is cleared to 0.

- When DMATCR is 0: When the DMATCR value becomes 0 and the corresponding channel's DMA transfer ends, the transfer end flag bit (TE) is set in the CHCR. If the IE (interrupt enable) bit has been set, a DMAC interrupt (DEI) is requested of the CPU.
- When DE of CHCR is 0: Software can halt a DMA transfer by clearing the DE bit in the channel's CHCR. The TE bit is not set when this happens.

Conditions for Ending All Channels Simultaneously: Transfers on all channels end when the NMIF (NMI flag) bit or AE (address error flag) bit is set to 1 in the DMAOR, or when the DME bit in the DMAOR is cleared to 0.

- When the NMIF or AE bit is set to 1 in DMAOR: When an NMI interrupt or DMAC address error occurs, the NMIF or AE bit is set to 1 in the DMAOR and all channels stop their transfers. The DMAC obtains the bus mastership, and if these flags are set to 1 during execution of a transfer, DMAC halts operation when the transfer processing currently being executed ends, and transfers the bus mastership to the other bus master. Consequently, even if the NMIF or AE bits are set to 1 during a transfer, the DMA source address register (SAR), designation address register (DAR), and transfer count register (TCR) are all updated. The TE bit is not set. To resume the transfers after NMI interrupt or address error processing, clear the appropriate flag bit to 0. To avoid restarting a transfer on a particular channel, clear its DE bit to 0.

Transfer is halted when the processing of a one unit transfer is complete. In a dual address mode direct address transfer, even if an address error occurs or the NMI flag is set during read processing, the transfer will not be halted until after completion of the following write processing. In such a case, SAR, DAR, and TCR values are updated. In the same manner, the transfer is not halted in dual address mode indirect address transfers until after the final write processing has ended.

- When DME is cleared to 0 in DMAOR: Clearing the DME bit to 0 in the DMAOR aborts the transfers on all channels. The TE bit is not set.

10.4.8 DMAC Access from CPU

The space addressed by the DMAC is 3-cycle space. Therefore, when the CPU becomes the bus master and accesses the DMAC, a minimum of three system clock (ϕ) cycles are required for one bus cycle. Also, since the DMAC is located in word space, while a word-size access to the DMAC is completed in one bus cycle, a longword-size access is automatically divided into two word accesses, requiring two bus cycles (six basic clock cycles). These two bus cycles are executed consecutively; a different bus cycle is never inserted between the two word accesses. This applies to both write accesses and read accesses.

10.5 Examples of Use

10.5.1 Example of DMA Transfer between On-Chip SCI and External Memory

In this example, on-chip serial communication interface channel 0 (SCI0) received data is transferred to external memory using the DMAC channel 3.

Table 10.6 indicates the transfer conditions and the setting values of each of the registers.

Table 10.6 Transfer Conditions and Register Set Values for Transfer between On-chip SCI and External Memory

| Transfer Conditions | Register | Value |
|---|----------|------------|
| Transfer source: RDR0 of on-chip SCI0 | SAR_3 | H'FFFF81A5 |
| Transfer destination: external memory | DAR_3 | H'00400000 |
| Transfer count: 64 times | DMATCR_3 | H'00000040 |
| Transfer source address: fixed | CHCR_3 | H'00004D05 |
| Transfer destination address: incremented | | |
| Transfer request source: SCI0 (RDR0) | | |
| Bus mode: cycle steal | | |
| Transfer unit: byte | | |
| Interrupt request generation at end of transfer | | |
| Channel priority ranking: 0 > 1 > 2 > 3 | DMAOR | H'0001 |

10.5.2 Example of DMA Transfer between External RAM and External Device with DACK

Below is an transfer example in which the transfer source is an external memory and the transfer destination is an external device with DACK, using channel 1 of the DMAC which requires an external request in single address mode.

Table 10.7 indicates the transfer conditions and the setting values of each of the registers.

Table 10.7 Transfer Conditions and Register Set Values for Transfer between External RAM and External Device with DACK

| Transfer Conditions | Register | Value |
|--|-----------------|------------------|
| Transfer source: external RAM | SAR_1 | H'00400000 |
| Transfer destination: external device with DACK | DAR_1 | (access by DACK) |
| Transfer count: 32 times | DMATCR_1 | H'00000020 |
| Transfer source address: decremented | CHCR_1 | H'00002269 |
| Transfer destination address: (setting ineffective) | | |
| Transfer request source: external pin ($\overline{\text{DREQ1}}$) edge detection | | |
| Bus mode: burst | | |
| Transfer unit: word | | |
| No interrupt request generation at end of transfer | | |
| Channel priority ranking: 2 > 0 > 1 > 3 | DMAOR | H'0201 |

10.5.3 Example of DMA Transfer between A/D Converter and On-chip Memory (Address Reload On)

In this example, the on-chip A/D converter channel 0 is the transfer source and on-chip memory is the transfer destination, and the address reload function is on.

Table 10.8 indicates the transfer conditions and the setting values of each of the registers.

Table 10.8 Transfer Conditions and Register Set Values for Transfer between A/D Converter (A/D1) and On-chip Memory

| Transfer Conditions | Register | Value |
|---|----------|------------|
| Transfer source: on-chip A/D converter (A/D1) | SAR_2 | H'FFFF8428 |
| Transfer destination: on-chip memory | DAR_2 | H'FFFFFF00 |
| Transfer count: 128 times (reload count 32 times) | DMATCR_2 | H'00000080 |
| Transfer source address: incremented | CHCR_2 | H'00085B25 |
| Transfer destination address: incremented | | |
| Transfer request source: A/D converter (A/D 1) | | |
| Bus mode: burst | | |
| Transfer unit: byte | | |
| Interrupt request generation at end of transfer | | |
| Channel priority ranking: 0 > 2 > 3 > 1 | DMAOR | H'0101 |

When address reload is on, the SAR value returns to its initially established value every four transfers. In the above example, when a transfer request is input from the A/D converter (A/D1), the byte size data is first read from the H'FFFF8428 register of the A/D converter (AD1) and that data is written to the on-chip memory address H'FFFFFF00. Because a byte size transfer was performed, the SAR and DAR values at this point are H'FFFF8429 and H'FFFFFF01, respectively. Also, because this is a burst transfer, the bus mastership remain secured, so continuous data transfer is possible.

When four transfers are completed, if the address reload is off, execution continues with the fifth and sixth transfers and the SAR value continues to increment from H'FFFF842B to H'FFFF842C to H'FFFF842D and so on. However, when the address reload is on, the DMAC transfer is halted upon completion of the fourth one and the bus mastership request signal to the CPU is cleared. At this time, the value stored in SAR is not H'FFFF842B to H'FFFF842C, but H'FFFF842B to H'FFFF8428, a return to the initially established address. The DAR value always continues to be incremented regardless of whether the address reload is on or off.

The DMAC internal status, due to the above operation after completion of the fourth transfer, is indicated in table 10.9 for both address reload on and off.

Table 10.9 DMAC Internal Status

| Item | Address Reload On | Address Reload Off |
|------------------------------------|-------------------|----------------------|
| SAR | H'FFFF8428 | H'FFFF842C |
| DAR | H'FFFFF004 | H'FFFFF004 |
| DMATCR | H'0000007C | H'0000007C |
| Bus mastership | Released | Maintained |
| DMAC operation | Halted | Processing continues |
| Interrupts | Not issued | Not issued |
| Transfer request source flag clear | Executed | Not executed |

- Notes:
1. Interrupts are executed until the DMATCR value becomes 0, and if the IE bit of the CHCR is set to 1, are issued regardless of whether the address reload is on or off.
 2. If transfer request source flag clears are executed until the DMATCR value becomes 0, they are executed regardless of whether the address reload is on or off.
 3. Designate burst mode when using the address reload function. There are cases where abnormal operation will result if it is executed in cycle steal mode.
 4. Designate a multiple of four for the DMATCR value when using the address reload function. There are cases where abnormal operation will result if anything else is designated.

To execute transfers after the fifth one when the address reload is on, make the transfer request source issue another transfer request signal.

10.5.4 Example of DMA Transfer between External Memory and SCI1 Transmit Side (Indirect Address On)

In this example, DMAC channel 3 is used, an indirect address designated external memory is the transfer source and the SCI1 transmit side is the transfer destination.

Table 10.10 indicates the transfer conditions and the setting values of each of the registers.

Table 10.10 Transfer Conditions and Register Set Values for Transfer between External Memory and SCI1 Transmit Side

| Transfer Conditions | Register | Value |
|--|----------|------------|
| Transfer source: external memory | SAR_3 | H'00400000 |
| Value stored in address H'00400000 | — | H'00450000 |
| Value stored in address H'00450000 | — | H'55 |
| Transfer destination: on-chip SCI1 (TDR1) | DAR_3 | H'FFFF81B3 |
| Transfer count: 10 times | DMATCR_3 | H'0000000A |
| Transfer source address: incremented | CHCR_3 | H'00011E01 |
| Transfer destination address: fixed | | |
| Transfer request source: SCI1 (TDR1) | | |
| Bus mode: cycle steal | | |
| Transfer unit: byte | | |
| Interrupt request not generated at end of transfer | | |
| Channel priority ranking: 0 > 1 > 2 > 3 | DMAOR | H'0001 |

When indirect address mode is on, the data stored in the address established in SAR is not used as the transfer source data. In the case of indirect addressing, the value stored in the SAR address is read, then that value is used as the address and the data read from that address is used as the transfer source data, then that data is stored in the address designated by the DAR.

In the table 10.10 example, when a transfer request from the TDR_1 of SCI_1 is generated, a read of the address located at H'00400000, which is the value set in SAR_3, is performed first. The data H'00450000 is stored at this H'00400000 address, and the DMAC first reads this H'00450000 value. It then uses this read value of H'00450000 as an address and reads the value of H'55 that is stored in the H'00450000 address. It then writes the value H'55 to the address H'FFFF81B3 designated by DAR_3 to complete one indirect address transfer.

With indirect addressing, the first executed data read from the address established in SAR_3 always results in a longword size transfer regardless of the TS0, TS1 bit designations for transfer data size. However, the transfer source address fixed and increment or decrement designations are as according to the SM0, SM1 bits. Consequently, despite the fact that the transfer data size designation is byte in this example, the SAR_3 value at the end of one transfer is H'00400004. The write operation is exactly the same as an ordinary dual address transfer write operation.

10.6 Usage Notes

1. The DMA operation register (DMAOR) can be accessed only in word (16-bit) units. The other registers can be accessed in word (16-bit) or longword (32-bit) units.
2. When rewriting the RS0 to RS3 bits of CHCR_0 to CHCR_3, first clear the DE bit to 0 (set the DE bit to 0 before doing rewrites with CHCR).
3. When an NMI interrupt is input, the NMIF bit of the DMAOR is set even when the DMAC is not operating.
4. Set the DME bit of the DMAOR to 0 and make certain that any DMAC received transfer request processing has been completed before entering standby mode.
5. Do not access the DMAC, DTC, BSC, or UBC on-chip peripheral modules from the DMAC.
6. When activating the DMAC, do the CHCR or DMAOR setting as the final step. There are instances where abnormal operation will result if any other registers are established last.
7. After the DMATCR count becomes 0 and the DMA transfer ends normally, always write a 0 to the DMATCR, even when executing the maximum number of transfers on the same channel. There are instances where abnormal operation will result if this is not done.
8. Designate burst mode as the transfer mode when using the address reload function. There are instances where abnormal operation will result in cycle steal mode.
9. Designate a multiple of four for the DMATCR value when using the address reload function. There are instances where abnormal operation will result if anything else is designated.
10. When detecting external requests by falling edge, maintain the external request pin at high level when performing the DMAC establishment.
11. When operating in single address mode, establish an external address as the address. There are instances where abnormal operation will result if an internal address is established.
12. Do not access DMAC register empty addresses (H'FFFF86B2 to H'FFFF86BF). Operation cannot be guaranteed when empty addresses are accessed.

Section 11 Multi-Function Timer Pulse Unit (MTU)

This LSI has an on-chip multi-function timer pulse unit (MTU) that comprises five 16-bit timer channels.

The block diagram is shown in figure 11.1.

11.1 Features

- Maximum 16-pulse input/output
- Selection of 8 counter input clocks for each channel
- The following operations can be set for each channel:
 - Waveform output at compare match
 - Input capture function
 - Counter clear operation
 - Multiple timer counters (TCNT) can be written to simultaneously
 - Simultaneous clearing by compare match and input capture is possible
 - Register simultaneous input/output is possible by synchronous counter operation
 - A maximum 12-phase PWM output is possible in combination with synchronous operation
- Buffer operation settable for channels 0, 3, and 4
- Phase counting mode settable independently for each of channels 1 and 2
- Cascade connection operation
- Fast access via internal 16-bit bus
- 23 interrupt sources
- Automatic transfer of register data
- A/D converter conversion start trigger can be generated
- Module standby mode can be settable
- A total of six-phase waveform output, which includes complementary PWM output, and positive and negative phases of reset PWM output by interlocking operation of channels 3 and 4, is possible.
- AC synchronous motor (brushless DC motor) drive mode using complementary PWM output and reset PWM output is settable by interlocking operation of channels 0, 3, and 4, and the selection of two types of waveform outputs (chopping and level) is possible.

Table 11.1 MTU Functions

| Item | | Channel 0 | Channel 1 | Channel 2 | Channel 3 | Channel 4 |
|--|------------------|--|--|--|--|--|
| Count clock | | P ϕ /1 | P ϕ /1 | P ϕ /1 | P ϕ /1 | P ϕ /1 |
| | | P ϕ /4 | P ϕ /4 | P ϕ /4 | P ϕ /4 | P ϕ /4 |
| | | P ϕ /16 | P ϕ /16 | P ϕ /16 | P ϕ /16 | P ϕ /16 |
| | | P ϕ /64 | P ϕ /64 | P ϕ /64 | P ϕ /64 | P ϕ /64 |
| | | TCLKA | P ϕ /256 | P ϕ /1024 | P ϕ /256 | P ϕ /256 |
| | | TCLKB | TCLKA | TCLKA | P ϕ /1024 | P ϕ /1024 |
| | | TCLKC | TCLKB | TCLKB | TCLKA | TCLKA |
| | | TCLKD | | TCLKC | TCLKB | TCLKB |
| General registers | | TGRA_0 | TGRA_1 | TGRA_2 | TGRA_3 | TGRA_4 |
| | | TGRB_0 | TGRB_1 | TGRB_2 | TGRB_3 | TGRB_4 |
| General registers/ buffer registers | | TGRC_0 | — | — | TGRC_3 | TGRC_4 |
| | | TGRD_0 | | | TGRD_3 | TGRD_4 |
| I/O pins | | TIOC0A | TIOC1A | TIOC2A | TIOC3A | TIOC4A |
| | | TIOC0B | TIOC1B | TIOC2B | TIOC3B | TIOC4B |
| | | TIOC0C | | | TIOC3C | TIOC4C |
| | | TIOC0D | | | TIOC3D | TIOC4D |
| Counter clear function | | TGR compare match or input capture | TGR compare match or input capture | TGR compare match or input capture | TGR compare match or input capture | TGR compare match or input capture |
| Compare match output | 0 output | <input type="radio"/> | <input type="radio"/> | <input type="radio"/> | <input type="radio"/> | <input type="radio"/> |
| | 1 output | <input type="radio"/> | <input type="radio"/> | <input type="radio"/> | <input type="radio"/> | <input type="radio"/> |
| | Toggle output | <input type="radio"/> | <input type="radio"/> | <input type="radio"/> | <input type="radio"/> | <input type="radio"/> |
| Input capture function | | <input type="radio"/> | <input type="radio"/> | <input type="radio"/> | <input type="radio"/> | <input type="radio"/> |
| Synchronous operation | | <input type="radio"/> | <input type="radio"/> | <input type="radio"/> | <input type="radio"/> | <input type="radio"/> |
| PWM mode 1 | | <input type="radio"/> | <input type="radio"/> | <input type="radio"/> | <input type="radio"/> | <input type="radio"/> |
| PWM mode 2 | | <input type="radio"/> | <input type="radio"/> | <input type="radio"/> | — | — |
| Complementary PWM mode | | — | — | — | <input type="radio"/> | <input type="radio"/> |
| Reset PMW mode | | — | — | — | <input type="radio"/> | <input type="radio"/> |
| AC synchronous motor drive mode | | <input type="radio"/> | — | — | <input type="radio"/> | <input type="radio"/> |
| Phase counting mode | | — | <input type="radio"/> | <input type="radio"/> | — | — |

| Item | Channel 0 | Channel 1 | Channel 2 | Channel 3 | Channel 4 |
|--------------------------------|--|---|---|--|---|
| Buffer operation | ○ | — | — | ○ | ○ |
| DMAC activation | TGRA_0 compare match or input capture | TGRA_1 compare match or input capture | TGRA_2 compare match or input capture | TGRA_3 compare match or input capture | TGRA_4 compare match or input capture |
| DTC activation | TGR compare match or input capture | TGR compare match or input capture | TGR compare match or input capture | TGR compare match or input capture | TGR compare match or input capture and TCNT overflow or underflow |
| A/D converter start trigger | TGRA_0 compare match or input capture | TGRA_1 compare match or input capture | TGRA_2 compare match or input capture | TGRA_3 compare match or input capture | TGRA_4 compare match or input capture |
| Interrupt sources | 5 sources <ul style="list-style-type: none"> • Compare match or input capture 0A • Compare match or input capture 0B • Compare match or input capture 0C • Compare match or input capture 0D • Overflow | 4 sources <ul style="list-style-type: none"> • Compare match or input capture 1A • Compare match or input capture 1B • Overflow • Underflow | 4 sources <ul style="list-style-type: none"> • Compare match or input capture 2A • Compare match or input capture 2B • Overflow • Underflow | 5 sources <ul style="list-style-type: none"> • Compare match or input capture 3A • Compare match or input capture 3B • Compare match or input capture 3C • Compare match or input capture 3D • Overflow | 5 sources <ul style="list-style-type: none"> • Compare match or input capture 4A • Compare match or input capture 4B • Compare match or input capture 4C • Compare match or input capture 4D • Overflow or underflow |

[Legend]

- : Possible
—: Not possible

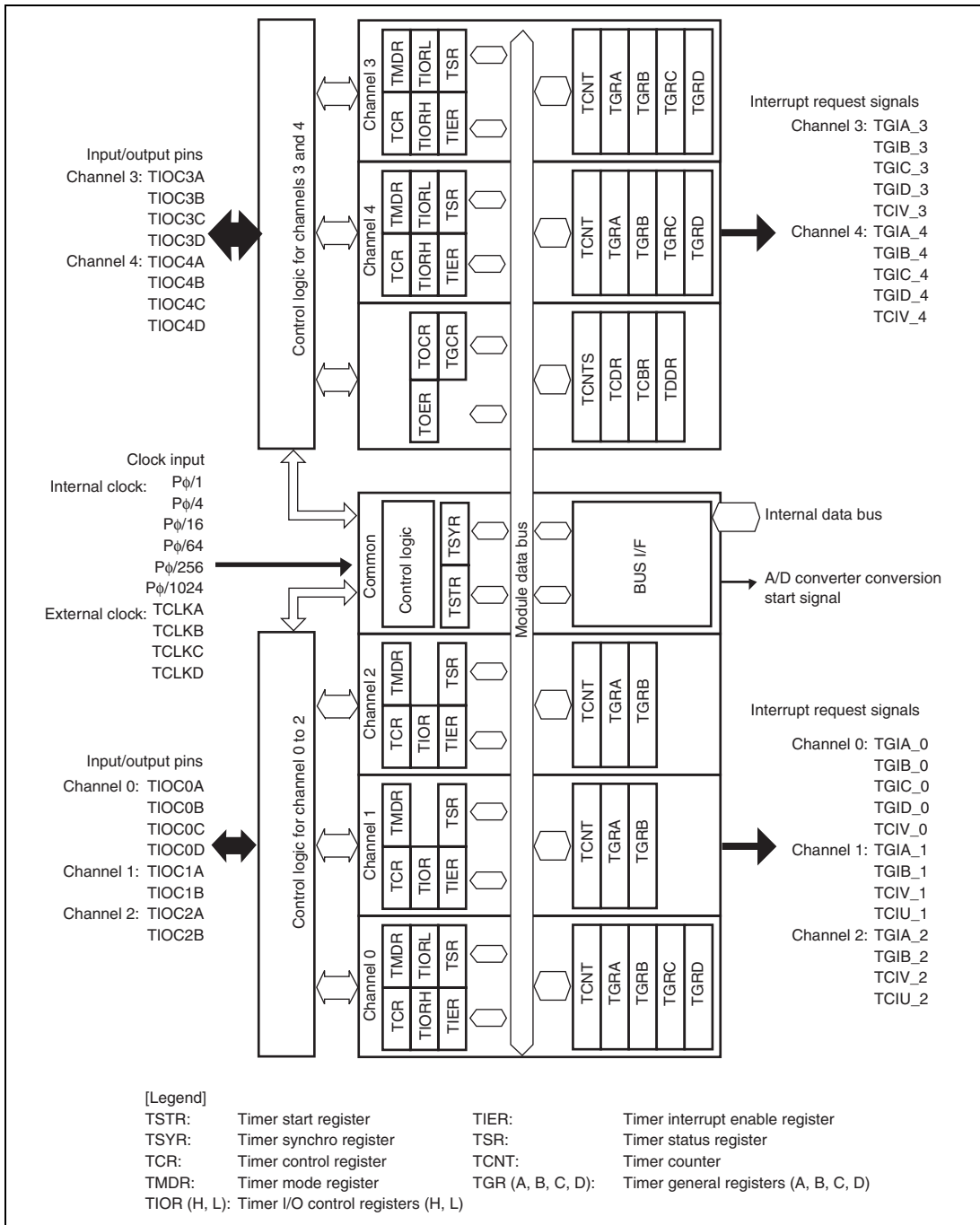

Figure 11.1 Block Diagram of MTU

11.2 Input/Output Pins

Table 11.2 Pin Configuration

| Channel | Symbol | I/O | Function |
|---------|--------|-------|---|
| Common | TCLKA | Input | External clock A input pin (Channel 1 phase counting mode A phase input) |
| | TCLKB | Input | External clock B input pin (Channel 1 phase counting mode B phase input) |
| | TCLKC | Input | External clock C input pin (Channel 2 phase counting mode A phase input) |
| | TCLKD | Input | External clock D input pin (Channel 2 phase counting mode B phase input) |
| 0 | TIOC0A | I/O | TGRA_0 input capture input/output compare output/PWM output pin |
| | TIOC0B | I/O | TGRB_0 input capture input/output compare output/PWM output pin |
| | TIOC0C | I/O | TGRC_0 input capture input/output compare output/PWM output pin |
| | TIOC0D | I/O | TGRD_0 input capture input/output compare output/PWM output pin |
| 1 | TIOC1A | I/O | TGRA_1 input capture input/output compare output/PWM output pin |
| | TIOC1B | I/O | TGRB_1 input capture input/output compare output/PWM output pin |
| 2 | TIOC2A | I/O | TGRA_2 input capture input/output compare output/PWM output pin |
| | TIOC2B | I/O | TGRB_2 input capture input/output compare output/PWM output pin |
| 3 | TIOC3A | I/O | TGRA_3 input capture input/output compare output/PWM output pin |
| | TIOC3B | I/O | TGRB_3 input capture input/output compare output/PWM output pin |
| | TIOC3C | I/O | TGRC_3 input capture input/output compare output/PWM output pin |
| | TIOC3D | I/O | TGRD_3 input capture input/output compare output/PWM output pin |
| 4 | TIOC4A | I/O | TGRA_4 input capture input/output compare output/PWM output pin |
| | TIOC4B | I/O | TGRB_4 input capture input/output compare output/PWM output pin |
| | TIOC4C | I/O | TGRC_4 input capture input/output compare output/PWM output pin |
| | TIOC4D | I/O | TGRD_4 input capture input/output compare output/PWM output pin |

11.3 Register Descriptions

The MTU has the following registers. For details on register addresses and register states during each process, refer to section 25, List of Registers. To distinguish registers in each channel, an underscore and the channel number are added as a suffix to the register name; TCR for channel 0 is expressed as TCR_0.

- Timer control register_0 (TCR_0)
- Timer mode register_0 (TMDR_0)
- Timer I/O control register H_0 (TIORH_0)
- Timer I/O control register L_0 (TIORL_0)
- Timer interrupt enable register_0 (TIER_0)
- Timer status register_0 (TSR_0)
- Timer counter_0 (TCNT_0)
- Timer general register A_0 (TGRA_0)
- Timer general register B_0 (TGRB_0)
- Timer general register C_0 (TGRC_0)
- Timer general register D_0 (TGRD_0)
- Timer control register_1 (TCR_1)
- Timer mode register_1 (TMDR_1)
- Timer I/O control register_1 (TIOR_1)
- Timer interrupt enable register_1 (TIER_1)
- Timer status register_1 (TSR_1)
- Timer counter_1 (TCNT_1)
- Timer general register A_1 (TGRA_1)
- Timer general register B_1 (TGRB_1)
- Timer control register_2 (TCR_2)
- Timer mode register_2 (TMDR_2)
- Timer I/O control register_2 (TIOR_2)
- Timer interrupt enable register_2 (TIER_2)
- Timer status register_2 (TSR_2)
- Timer counter_2 (TCNT_2)
- Timer general register A_2 (TGRA_2)
- Timer general register B_2 (TGRB_2)
- Timer control register_3 (TCR_3)
- Timer mode register_3 (TMDR_3)

- Timer I/O control register H_3 (TIORH_3)
- Timer I/O control register L_3 (TIORL_3)
- Timer interrupt enable register_3 (TIER_3)
- Timer status register_3 (TSR_3)
- Timer counter_3 (TCNT_3)
- Timer general register A_3 (TGRA_3)
- Timer general register B_3 (TGRB_3)
- Timer general register C_3 (TGRC_3)
- Timer general register D_3 (TGRD_3)
- Timer control register_4 (TCR_4)
- Timer mode register_4 (TMDR_4)
- Timer I/O control register H_4 (TIORH_4)
- Timer I/O control register L_4 (TIORL_4)
- Timer interrupt enable register_4 (TIER_4)
- Timer status register_4 (TSR_4)
- Timer counter_4 (TCNT_4)
- Timer general register A_4 (TGRA_4)
- Timer general register B_4 (TGRB_4)
- Timer general register C_4 (TGRC_4)
- Timer general register D_4 (TGRD_4)

Common Registers

- Timer start register (TSTR)
- Timer synchronous register (TSYR)

Common Registers for timers 3 and 4

- Timer output master enable register (TOER)
- Timer output control enable register (TOCR)
- Timer gate control register (TGCR)
- Timer cycle data register (TCDR)
- Timer dead time data register (TDDR)
- Timer subcounter (TCNTS)
- Timer cycle buffer register (TCBR)

11.3.1 Timer Control Register (TCR)

The TCR registers are 8-bit readable/writable registers that control the TCNT operation for each channel. The MTU has a total of five TCR registers, one for each channel (channel 0 to 4). TCR register settings should be conducted only when TCNT operation is stopped.

| Bit | Bit Name | Initial Value | R/W | Description |
|-----|----------|---------------|-----|--|
| 7 | CCLR2 | 0 | R/W | Counter Clear 0 to 2 |
| 6 | CCLR1 | 0 | R/W | These bits select the TCNT counter clearing source. See tables 11.3 and 11.4 for details. |
| 5 | CCLR0 | 0 | R/W | |
| 4 | CKEG1 | 0 | R/W | Clock Edge 0 and 1 |
| 3 | CKEG0 | 0 | R/W | <p>These bits select the input clock edge. When the input clock is counted using both edges, the input clock period is halved (e.g. $P\phi/4$ both edges = $P\phi/2$ rising edge). If phase counting mode is used on channels 1 and 2, this setting is ignored and the phase counting mode setting has priority. Internal clock edge selection is valid when the input clock is $P\phi/4$ or slower. When $P\phi/1$, or the overflow/underflow of another channel is selected for the input clock, although values can be written, counter operation compiles with the initial value.</p> <p>00: Count at rising edge 01: Count at falling edge 1X: Count at both edges</p> <p>[Legend] X: Don't care</p> |
| 2 | TPSC2 | 0 | R/W | Time Prescaler 0 to 2 |
| 1 | TPSC1 | 0 | R/W | These bits select the TCNT counter clock. The clock source can be selected independently for each channel. See tables 11.5 to 11.8 for details. |
| 0 | TPSC0 | 0 | R/W | |

Table 11.3 CCLR0 to CCLR2 (Channels 0, 3, and 4)

| Channel | Bit 7 CCLR2 | Bit 6 CCLR1 | Bit 5 CCLR0 | Description |
|---------|----------------|----------------|----------------|--|
| 0, 3, 4 | 0 | 0 | 0 | TCNT clearing disabled |
| | | | 1 | TCNT cleared by TGRA compare match/input capture |
| | | | 0 | TCNT cleared by TGRB compare match/input capture |
| | | | 1 | TCNT cleared by counter clearing for another channel performing synchronous clearing/ synchronous operation* ¹ |
| 1 | 0 | 0 | 0 | TCNT clearing disabled |
| | | | 1 | TCNT cleared by TGRC compare match/input capture* ² |
| | | | 0 | TCNT cleared by TGRD compare match/input capture* ² |
| | | | 1 | TCNT cleared by counter clearing for another channel performing synchronous clearing/ synchronous operation* ¹ |

- Notes: 1. Synchronous operation is set by setting the SYNC bit in TSYR to 1.
 2. When TGRC or TGRD is used as a buffer register, TCNT is not cleared because the buffer register setting has priority, and compare match/input capture does not occur.

Table 11.4 CCLR0 to CCLR2 (Channels 1 and 2)

| Channel | Bit 7 Reserved* ² | Bit 6 CCLR1 | Bit 5 CCLR0 | Description |
|---------|---------------------------------|----------------|----------------|--|
| 1, 2 | 0 | 0 | 0 | TCNT clearing disabled |
| | | | 1 | TCNT cleared by TGRA compare match/input capture |
| | | | 0 | TCNT cleared by TGRB compare match/input capture |
| | | | 1 | TCNT cleared by counter clearing for another channel performing synchronous clearing/ synchronous operation* ¹ |

- Notes: 1. Synchronous operation is selected by setting the SYNC bit in TSYR to 1.
 2. Bit 7 is reserved in channels 1 and 2. It is always read as 0 and cannot be modified.

Table 11.5 TPSC0 to TPSC2 (Channel 0)

| Channel | Bit 2 TPSC2 | Bit 1 TPSC1 | Bit 0 TPSC0 | Description |
|---------|----------------|----------------|----------------|---|
| 0 | 0 | 0 | 0 | Internal clock: counts on P ϕ /1 |
| | | | 1 | Internal clock: counts on P ϕ /4 |
| | | | 0 | Internal clock: counts on P ϕ /16 |
| | | | 1 | Internal clock: counts on P ϕ /64 |
| | 1 | 0 | 0 | External clock: counts on TCLKA pin input |
| | | | 1 | External clock: counts on TCLKB pin input |
| | | | 0 | External clock: counts on TCLKC pin input |
| | | | 1 | External clock: counts on TCLKD pin input |

Table 11.6 TPSC0 to TPSC2 (Channel 1)

| Channel | Bit 2 TPSC2 | Bit 1 TPSC1 | Bit 0 TPSC0 | Description |
|---------|----------------|----------------|----------------|---|
| 1 | 0 | 0 | 0 | Internal clock: counts on P ϕ /1 |
| | | | 1 | Internal clock: counts on P ϕ /4 |
| | | | 0 | Internal clock: counts on P ϕ /16 |
| | | | 1 | Internal clock: counts on P ϕ /64 |
| | 1 | 0 | 0 | External clock: counts on TCLKA pin input |
| | | | 1 | External clock: counts on TCLKB pin input |
| | | | 0 | Internal clock: counts on P ϕ /256 |
| | | | 1 | Counts on TCNT_2 overflow/underflow |

Note: This setting is ignored when channel 1 is in phase counting mode.

Table 11.7 TPSC0 to TPSC2 (Channel 2)

| Channel | Bit 2 TPSC2 | Bit 1 TPSC1 | Bit 0 TPSC0 | Description |
|---------|----------------|----------------|----------------|---|
| 2 | 0 | 0 | 0 | Internal clock: counts on P ϕ /1 |
| | | | 1 | Internal clock: counts on P ϕ /4 |
| | | 1 | 0 | Internal clock: counts on P ϕ /16 |
| | | | 1 | Internal clock: counts on P ϕ /64 |
| | 1 | 0 | 0 | External clock: counts on TCLKA pin input |
| | | | 1 | External clock: counts on TCLKB pin input |
| | | 1 | 0 | External clock: counts on TCLKC pin input |
| | | | 1 | Internal clock: counts on P ϕ /1024 |

Note: This setting is ignored when channel 2 is in phase counting mode.

Table 11.8 TPSC0 to TPSC2 (Channels 3 and 4)

| Channel | Bit 2 TPSC2 | Bit 1 TPSC1 | Bit 0 TPSC0 | Description |
|---------|----------------|----------------|----------------|---|
| 3, 4 | 0 | 0 | 0 | Internal clock: counts on P ϕ /1 |
| | | | 1 | Internal clock: counts on P ϕ /4 |
| | | 1 | 0 | Internal clock: counts on P ϕ /16 |
| | | | 1 | Internal clock: counts on P ϕ /64 |
| | 1 | 0 | 0 | Internal clock: counts on P ϕ /256 |
| | | | 1 | Internal clock: counts on P ϕ /1024 |
| | | 1 | 0 | External clock: counts on TCLKA pin input |
| | | | 1 | External clock: counts on TCLKB pin input |

11.3.2 Timer Mode Register (TMDR)

The TMDR registers are 8-bit readable/writable registers that are used to set the operating mode of each channel. The MTU has five TMDR registers, one for each channel. TMDR register settings should be changed only when TCNT operation is stopped.

| Bit | Bit Name | Initial Value | R/W | Description |
|------|----------|---------------|-----|--|
| 7, 6 | — | All 1 | — | Reserved These bits are always read as 1. The write value should always be 1. |
| 5 | BFB | 0 | R/W | Buffer Operation B Specifies whether TGRB is to operate in the normal way, or TGRB and TGRD are to be used together for buffer operation. When TGRD is used as a buffer register, TGRD input capture/output compare is not generated. In channels 1 and 2, which have no TGRD, bit 5 is reserved. It is always read as 0 and cannot be modified. 0: TGRB and TGRD operate normally 1: TGRB and TGRD used together for buffer operation |
| 4 | BFA | 0 | R/W | Buffer Operation A Specifies whether TGRA is to operate in the normal way, or TGRA and TGRC are to be used together for buffer operation. When TGRC is used as a buffer register, TGRC input capture/output compare is not generated. In channels 1 and 2, which have no TGRC, bit 4 is reserved. It is always read as 0 and cannot be modified. 0: TGRA and TGRC operate normally 1: TGRA and TGRC used together for buffer operation |
| 3 | MD3 | 0 | R/W | Modes 0 to 3 |
| 2 | MD2 | 0 | R/W | These bits are used to set the timer operating mode. |
| 1 | MD1 | 0 | R/W | See table 11.9 for details. |
| 0 | MD0 | 0 | R/W | |

Table 11.9 MD0 to MD3

| Bit 3 MD3 | Bit 2 MD2 | Bit 1 MD1 | Bit 0 MD0 | Description |
|--------------|--------------|--------------|--------------|--|
| 0 | 0 | 0 | 0 | Normal operation |
| | | | 1 | Setting prohibited |
| | | 1 | 0 | PWM mode 1 |
| | | | 1 | PWM mode 2* ¹ |
| | 1 | 0 | 0 | Phase counting mode 1* ² |
| | | | 1 | Phase counting mode 2* ² |
| | | 1 | 0 | Phase counting mode 3* ² |
| | | | 1 | Phase counting mode 4* ² |
| 1 | 0 | 0 | 0 | Reset synchronous PWM mode* ³ |
| | | | 1 | Setting prohibited |
| | | 1 | X | Setting prohibited |
| | | | 0 | Setting prohibited |
| | 1 | 0 | 0 | Setting prohibited |
| | | | 1 | Complementary PWM mode 1 (transmit at peak)* ³ |
| | | 1 | 0 | Complementary PWM mode 2 (transmit at valley)* ³ |
| | | | 1 | Complementary PWM mode 2 (transmit at peak and valley)* ³ |

[Legend]

X: Don't care

- Notes:
1. PWM mode 2 can not be set for channels 3 and 4.
 2. Phase counting mode can not be set for channels 0, 3, and 4.
 3. Reset synchronous PWM mode, complementary PWM mode can only be set for channel 3. When channel 3 is set to reset synchronous PWM mode or complementary PWM mode, the channel 4 settings become ineffective and automatically conform to the channel 3 settings. However, do not set channel 4 to reset synchronous PWM mode or complementary PWM mode. Reset synchronous PWM mode and complementary PWM mode cannot be set for channels 0, 1, and 2.

11.3.3 Timer I/O Control Register (TIOR)

The TIOR registers are 8-bit readable/writable registers that control the TGR registers. The MTU has eight TIOR registers, two each for channels 0, 3, and 4, and one each for channels 1 and 2.

Care is required as TIOR is affected by the TMDR setting. The initial output specified by TIOR is valid when the counter is stopped (the CST bit in TSTR is cleared to 0). Note also that, in PWM mode 2, the output at the point at which the counter is cleared to 0 is specified.

When TGRC or TGRD is designated for buffer operation, this setting is invalid and the register operates as a buffer register.

- TIORH_0, TIOR_1, TIOR_2, TIORH_3, TIORH_4

| Bit | Bit Name | Initial Value | R/W | Description |
|-----|----------|---------------|-----|--|
| 7 | IOB3 | 0 | R/W | I/O Control B0 to B3 |
| 6 | IOB2 | 0 | R/W | Specify the function of TGRB. |
| 5 | IOB1 | 0 | R/W | See the following tables. |
| 4 | IOB0 | 0 | R/W | TIORH_0: Table 11.10 TIOR_1: Table 11.12 TIOR_2: Table 11.13 TIORH_3: Table 11.14 TIORH_4: Table 11.16 |
| 3 | IOA3 | 0 | R/W | I/O Control A0 to A3 |
| 2 | IOA2 | 0 | R/W | Specify the function of TGRA. |
| 1 | IOA1 | 0 | R/W | See the following tables. |
| 0 | IOA0 | 0 | R/W | TIORH_0: Table 11.18 TIOR_1: Table 11.20 TIOR_2: Table 11.21 TIORH_3: Table 11.22 TIORH_4: Table 11.24 |

- TIORL_0, TIORL_3, TIORL_4

| Bit | Bit Name | Initial Value | R/W | Description |
|-----|----------|---------------|-----|--|
| 7 | IOD3 | 0 | R/W | I/O Control D0 to D3 |
| 6 | IOD2 | 0 | R/W | Specify the function of TGRD. |
| 5 | IOD1 | 0 | R/W | See the following tables. |
| 4 | IOD0 | 0 | R/W | TIORL_0: Table 11.11 TIORL_3: Table 11.15 TIORL_4: Table 11.17 |
| 3 | IOC3 | 0 | R/W | I/O Control C0 to C3 |
| 2 | IOC2 | 0 | R/W | Specify the function of TGRC. |
| 1 | IOC1 | 0 | R/W | See the following tables. |
| 0 | IOC0 | 0 | R/W | TIORL_0: Table 11.19 TIORL_3: Table 11.23 TIORL_4: Table 11.25 |

Table 11.10 TIORH_0 (Channel 0)

| Bit 7 IOB3 | Bit 6 IOB2 | Bit 5 IOB1 | Bit 4 IOB0 | Description | | |
|---------------|---------------|---------------|---------------|---|---|--|
| | | | | TGRB_0 Function | TIOC0B Pin Function | |
| 0 | 0 | 0 | 0 | Output compare register | Output retained* | |
| | | | 1 | | Initial output is 0 0 output at compare match | |
| | | 1 | 0 | | Initial output is 0 1 output at compare match | |
| | | | 1 | | Initial output is 0 Toggle output at compare match | |
| | | 1 | 0 | | 0 | Output retained |
| | | | | | 1 | Initial output is 1 0 output at compare match |
| | 1 | 0 | 0 | Initial output is 1 1 output at compare match | | |
| | | | 1 | Initial output is 1 Toggle output at compare match | | |
| | 1 | 0 | 0 | 0 | Input capture register | Input capture at rising edge |
| | | | | 1 | | Input capture at falling edge |
| | | 1 | X | Input capture at both edges | | |
| | | | X | Capture input source is channel 1/count clock Input capture at TCNT_1 count- up/count-down | | |

[Legend]

X: Don't care

Note: * After power-on reset, 0 is output until TIOR is set.

Table 11.11 TIORL_0 (Channel 0)

| | | | | Description | | |
|---------------|---------------|---------------|--|--|---|---|
| Bit 7 IOD3 | Bit 6 IOD2 | Bit 5 IOD1 | Bit 4 IOD0 | TGRD_0 Function | TIOC0D Pin Function | |
| 0 | 0 | 0 | 0 | Output compare register* ² | Output retained* ¹ | |
| | | | 1 | | Initial output is 0 0 output at compare match | |
| | | 1 | 0 | | Initial output is 0 1 output at compare match | |
| | | | 1 | | Initial output is 0 Toggle output at compare match | |
| | 1 | 0 | 0 | Input capture register* ² | Output retained | |
| | | | 1 | | Initial output is 1 0 output at compare match | |
| | | | 1 | | Initial output is 1 1 output at compare match | |
| | | 1 | 0 | | 0 | Initial output is 1 Toggle output at compare match |
| | | | | | 1 | Initial output is 1 Toggle output at compare match |
| | | | X | | X | Input capture at rising edge |
| 1 | 0 | 0 | Input capture register* ² | Input capture at rising edge | | |
| | | 1 | | Input capture at falling edge | | |
| | 1 | X | | Input capture at both edges | | |
| | | X | | Capture input source is channel 1/count clock Input capture at TCNT_1 count-up/count-down | | |

[Legend]

X: Don't care

Notes: 1. After power-on reset, 0 is output until TIOR is set.

2. When the BFB bit in TMDR_0 is set to 1 and TGRD_0 is used as a buffer register, this setting is invalid and input capture/output compare is not generated.

Table 11.12 TIOR_1 (Channel 1)

| Bit 7 IOB3 | Bit 6 IOB2 | Bit 5 IOB1 | Bit 4 IOB0 | Description | | |
|---------------|---------------|---------------|---|-------------------------------|--|--|
| | | | | TGRB_1 Function | TIOC1B Pin Function | |
| 0 | 0 | 0 | 0 | Output compare register | Output retained* | |
| | | | 1 | | Initial output is 0 0 output at compare match | |
| | | | 1 | | Initial output is 0 1 output at compare match | |
| | | 0 | Initial output is 0 Toggle output at compare match | | | |
| | | 1 | Output retained | | | |
| | | 1 | Initial output is 1 0 output at compare match | | | |
| | 1 | 0 | 0 | Input capture register | Input capture at rising edge | |
| | | | 1 | | Input capture at falling edge | |
| | | | X | | Input capture at both edges | |
| | | 1 | X | | X | Input capture at generation of TGRC_0 compare match/input capture |

[Legend]

X: Don't care

Note: * After power-on reset, 0 is output until TIOR is set.

Table 11.13 TIOR_2 (Channel 2)

| Bit 7 IOB3 | Bit 6 IOB2 | Bit 5 IOB1 | Bit 4 IOB0 | Description | |
|---------------|---------------|---------------|---------------|-------------------------------|---|
| | | | | TGRB_2 Function | TIOC2B Pin Function |
| 0 | 0 | 0 | 0 | Output compare register | Output retained* |
| | | | 1 | | Initial output is 0 0 output at compare match |
| | | 1 | 0 | | Initial output is 0 1 output at compare match |
| | | | 1 | | Initial output is 0 Toggle output at compare match |
| | 1 | 0 | 0 | | Output retained |
| | | | 1 | | Initial output is 1 0 output at compare match |
| | | 1 | 0 | | Initial output is 1 1 output at compare match |
| | | | 1 | | Initial output is 1 Toggle output at compare match |
| 1 | X | 0 | 0 | Input capture register | Input capture at rising edge |
| | | | 1 | | Input capture at falling edge |
| | | | X | | Input capture at both edges |

[Legend]

X: Don't care

Note: * After power-on reset, 0 is output until TIOR is set.

Table 11.14 TIORH_3 (Channel 3)

| Bit 7 IOB3 | Bit 6 IOB2 | Bit 5 IOB1 | Bit 4 IOB0 | Description | |
|---------------|---------------|---------------|---------------|-------------------------------|---|
| | | | | TGRB_3 Function | TIOC3B Pin Function |
| 0 | 0 | 0 | 0 | Output compare register | Output retained* |
| | | | 1 | | Initial output is 0 0 output at compare match |
| | | | 1 | | Initial output is 0 1 output at compare match |
| | | 1 | 0 | | Initial output is 0 Toggle output at compare match |
| | | | 1 | | Output retained |
| | | | 1 | | Initial output is 1 0 output at compare match |
| | 1 | 0 | 0 | Input capture register | Initial output is 1 1 output at compare match |
| | | | 1 | | Initial output is 1 Toggle output at compare match |
| | | | 1 | | Initial output is 1 Toggle output at compare match |
| | | 1 | 0 | | Input capture at rising edge |
| | | | 1 | | Input capture at falling edge |
| | | | X | | Input capture at both edges |

[Legend]

X: Don't care

Note: * After power-on reset, 0 is output until TIOR is set.

Table 11.15 TIORL_3 (Channel 3)

| | | | | Description | |
|---------------|---------------|---------------|---------------|---|--|
| Bit 7 IOD3 | Bit 6 IOD2 | Bit 5 IOD1 | Bit 4 IOD0 | TGRD_3 Function | TIOC3D Pin Function |
| 0 | 0 | 0 | 0 | Output compare register* ² | Output retained* ¹ |
| | | | 1 | | Initial output is 0 0 output at compare match |
| | | 1 | 0 | Initial output is 0 1 output at compare match | |
| | | | 1 | Initial output is 0 Toggle output at compare match | |
| | 1 | 0 | 0 | Input capture register* ² | Output retained |
| | | | 1 | | Initial output is 1 0 output at compare match |
| | | 1 | 0 | Initial output is 1 1 output at compare match | |
| | | | 1 | Initial output is 1 Toggle output at compare match | |
| 1 | X | 0 | 0 | Input capture at rising edge | |
| | | 1 | | Input capture at falling edge | |
| | | 1 | X | Input capture at both edges | |

[Legend]

X: Don't care

- Notes:
1. After power-on reset, 0 is output until TIOR is set.
 2. When the BFB bit in TMDR_3 is set to 1 and TGRD_3 is used as a buffer register, this setting is invalid and input capture/output compare is not generated.

Table 11.16 TIORH_4 (Channel 4)

| Bit 7 IOB3 | Bit 6 IOB2 | Bit 5 IOB1 | Bit 4 IOB0 | Description | | |
|---------------|--------------------------------|---------------|--------------------------------|-------------------------------|------------------------------|---------------------------|
| | | | | TGRB_4 Function | TIOC4B Pin Function | |
| 0 | 0 | 0 | 0 | Output compare register | Output retained* | |
| | | | 1 | | Initial output is 0 | |
| | | | | | 0 output at compare match | |
| | | | 1 | | Initial output is 0 | |
| | | | | | 1 output at compare match | |
| | | | 1 | | Initial output is 0 | |
| | | | Toggle output at compare match | | | |
| | | 1 | 0 | 0 | Input capture register | Output retained |
| | | | | 1 | | Initial output is 1 |
| | | | | | | 0 output at compare match |
| | | | | 1 | | Initial output is 1 |
| | | | | | | 1 output at compare match |
| 1 | Initial output is 1 | | | | | |
| | Toggle output at compare match | | | | | |
| 1 | X | 0 | Input capture register | Input capture at rising edge | | |
| | | 1 | | Input capture at falling edge | | |
| | | 1 | | Input capture at both edges | | |

[Legend]

X: Don't care

Note: * After power-on reset, 0 is output until TIOR is set.

Table 11.17 TIORL_4 (Channel 4)

| | | | | Description | |
|---------------|---------------|---------------|--|---|--|
| Bit 7 IOD3 | Bit 6 IOD2 | Bit 5 IOD1 | Bit 4 IOD0 | TGRD_4 Function | TIOC4D Pin Function |
| 0 | 0 | 0 | 0 | Output compare register* ² | Output retained* ¹ |
| | | | 1 | | Initial output is 0 0 output at compare match |
| | | 1 | 0 | Initial output is 0 1 output at compare match | |
| | | | 1 | Initial output is 0 Toggle output at compare match | |
| | 1 | 0 | 0 | Input capture register* ² | Output retained |
| | | | 1 | | Initial output is 1 0 output at compare match |
| | | 1 | 0 | Initial output is 1 1 output at compare match | |
| | | | 1 | Initial output is 1 Toggle output at compare match | |
| 1 | X | 0 | Input capture register* ² | Input capture at rising edge | |
| | | 1 | | Input capture at falling edge | |
| | | 1 | X | Input capture at both edges | |

[Legend]

X: Don't care

- Notes:
1. After power-on reset, 0 is output until TIOR is set.
 2. When the BFB bit in TMDR_4 is set to 1 and TGRD_4 is used as a buffer register, this setting is invalid and input capture/output compare is not generated.

Table 11.18 TIORH_0 (Channel 0)

| | | | | Description | |
|---------------|---------------|---------------|------------------------------|-------------------------------|---|
| Bit 3 IOA3 | Bit 2 IOA2 | Bit 1 IOA1 | Bit 0 IOA0 | TGRA_0 Function | TIOC0A Pin Function |
| 0 | 0 | 0 | 0 | Output compare register | Output retained* |
| | | | 1 | | Initial output is 0 |
| | | | | | 0 output at compare match |
| | | 1 | 0 | | Initial output is 0 |
| | | | | | 1 output at compare match |
| | | | 1 | | Initial output is 0 |
| | 1 | 0 | 0 | | Toggle output at compare match |
| | | | 1 | Output retained | |
| | | | | Initial output is 1 | |
| | | 1 | 0 | | 0 output at compare match |
| | | | | Initial output is 1 | |
| | | | 0 | 1 output at compare match | |
| 1 | 0 | 0 | Input capture register | Input capture at rising edge | |
| | | 1 | | Input capture at falling edge | |
| | | 1 | | Input capture at both edges | |
| | 1 | X | | | Capture input source is channel 1/count clock |
| | | | | | Input capture at TCNT_1 count-up/count-down |
| | | X | | | |

[Legend]

X: Don't care

Note: * After power-on reset, 0 is output until TIOR is set.

Table 11.19 TIORL_0 (Channel 0)

| | | | | Description | |
|---------------|---------------|---------------|--|---|---|
| Bit 3 IOC3 | Bit 2 IOC2 | Bit 1 IOC1 | Bit 0 IOC0 | TGRC_0 Function | TIOC0C Pin Function |
| 0 | 0 | 0 | 0 | Output compare register* ² | Output retained* ¹ |
| | | | 1 | | Initial output is 0 0 output at compare match |
| | | 1 | 0 | | Initial output is 0 1 output at compare match |
| | | | 1 | | Initial output is 0 Toggle output at compare match |
| | 1 | 0 | 0 | Output retained | |
| | | | 1 | Initial output is 1 0 output at compare match | |
| | | | 1 | Initial output is 1 1 output at compare match | |
| | | 1 | 0 | Initial output is 1 Toggle output at compare match | |
| | | | X | 0 | Input capture at rising edge |
| | | | | 1 | Input capture at falling edge |
| 1 | X | 1 | Input capture at both edges | | |
| | | X | Capture input source is channel 1/count clock Input capture at TCNT_1 count-up/count-down | | |

[Legend]

X: Don't care

- Notes:
1. After power-on reset, 0 is output until TIOR is set.
 2. When the BFA bit in TMDR_0 is set to 1 and TGRC_0 is used as a buffer register, this setting is invalid and input capture/output compare is not generated.

Table 11.20 TIOR_1 (Channel 1)

| Bit 3 IOA3 | Bit 2 IOA2 | Bit 1 IOA1 | Bit 0 IOA0 | Description | |
|---------------|---------------|---------------|------------------------------|--|---|
| | | | | TGRA_1 Function | TIOC1A Pin Function |
| 0 | 0 | 0 | 0 | Output compare register | Output retained* |
| | | | 1 | | Initial output is 0 0 output at compare match |
| | | 1 | 0 | | Initial output is 0 1 output at compare match |
| | | | 1 | | Initial output is 0 Toggle output at compare match |
| | 1 | 0 | 0 | | Output retained |
| | | | 1 | | Initial output is 1 0 output at compare match |
| | | 1 | 0 | | Initial output is 1 1 output at compare match |
| | | | 1 | | Initial output is 1 Toggle output at compare match |
| 1 | 0 | 0 | Input capture register | Input capture at rising edge | |
| | | 1 | | Input capture at falling edge | |
| | 1 | X | | Input capture at both edges | |
| | | X | | Input capture at generation of channel 0/TGRA_0 compare match/input capture | |

[Legend]

X: Don't care

Note: * After power-on reset, 0 is output until TIOR is set.

Table 11.21 TIOR_2 (Channel 2)

| Bit 3 IOA3 | Bit 2 IOA2 | Bit 1 IOA1 | Bit 0 IOA0 | TGRA_2 Function | Description |
|---------------|---------------|---------------|---------------|---|---|
| | | | | | TIOC2A Pin Function |
| 0 | 0 | 0 | 0 | Output compare register | Output retained* |
| | | | 1 | | Initial output is 0 0 output at compare match |
| | | 1 | 0 | | Initial output is 0 1 output at compare match |
| | | | 1 | | Initial output is 0 Toggle output at compare match |
| | 1 | 0 | 0 | Output retained | |
| | | | 1 | Initial output is 1 0 output at compare match | |
| | | 1 | 0 | Initial output is 1 1 output at compare match | |
| | | | 1 | Initial output is 1 Toggle output at compare match | |
| 1 | X | 0 | 0 | Input capture register | Input capture at rising edge |
| | | | 1 | | Input capture at falling edge |
| | | 1 | X | | Input capture at both edges |

[Legend]

X: Don't care

Note: * After power-on reset, 0 is output until TIOR is set.

Table 11.22 TIORH_3 (Channel 3)

| Bit 3 IOA3 | Bit 2 IOA2 | Bit 1 IOA1 | Bit 0 IOA0 | Description | |
|---------------|---------------|---------------|---------------|-------------------------------|---|
| | | | | TGRA_3 Function | TIOC3A Pin Function |
| 0 | 0 | 0 | 0 | Output compare register | Output retained* |
| | | | 1 | | Initial output is 0 0 output at compare match |
| | | | 1 | | Initial output is 0 1 output at compare match |
| | | 1 | 0 | | Initial output is 0 Toggle output at compare match |
| | | | 1 | | Output retained |
| | | | 1 | | Initial output is 1 0 output at compare match |
| | 1 | 0 | 0 | Input capture register | Initial output is 1 1 output at compare match |
| | | | 1 | | Initial output is 1 Toggle output at compare match |
| | | | 1 | | Initial output is 1 Toggle output at compare match |
| | | 1 | 0 | | Input capture at rising edge |
| | | | 1 | | Input capture at falling edge |
| | | | X | | Input capture at both edges |

[Legend]

X: Don't care

Note: * After power-on reset, 0 is output until TIOR is set.

Table 11.23 TIORL_3 (Channel 3)

| | | | | Description | |
|---------------|---------------|---------------|---------------|---|---|
| Bit 3 IOC3 | Bit 2 IOC2 | Bit 1 IOC1 | Bit 0 IOC0 | TGRC_3 Function | TIOC3C Pin Function |
| 0 | 0 | 0 | 0 | Output compare register* ² | Output retained* ¹ |
| | | | 1 | | Initial output is 0 0 output at compare match |
| | | 1 | 0 | | Initial output is 0 1 output at compare match |
| | | | 1 | | Initial output is 0 Toggle output at compare match |
| | 1 | 0 | 0 | Output retained | |
| | | | 1 | Initial output is 1 0 output at compare match | |
| | | 1 | 0 | Initial output is 1 1 output at compare match | |
| | | | 1 | Initial output is 1 Toggle output at compare match | |
| 1 | X | 0 | 0 | Input capture register* ² | Input capture at rising edge |
| | | | 1 | Input capture at falling edge | |
| | | 1 | X | Input capture at both edges | |

[Legend]

X: Don't care

- Notes:
1. After power-on reset, 0 is output until TIOR is set.
 2. When the BFA bit in TMDR_3 is set to 1 and TGRC_3 is used as a buffer register, this setting is invalid and input capture/output compare is not generated.

Table 11.24 TIORH_4 (Channel 4)

| Bit 3 IOA3 | Bit 2 IOA2 | Bit 1 IOA1 | Bit 0 IOA0 | Description | |
|---------------|---------------|---------------|---------------|-------------------------------|---|
| | | | | TGRA_4 Function | TIOC4A Pin Function |
| 0 | 0 | 0 | 0 | Output compare register | Output retained* |
| | | | 1 | | Initial output is 0 0 output at compare match |
| | | 1 | 0 | | Initial output is 0 1 output at compare match |
| | | | 1 | | Initial output is 0 Toggle output at compare match |
| | | 1 | 0 | | Output retained Initial output is 1 0 output at compare match |
| | | | 1 | | Initial output is 1 1 output at compare match |
| | 1 | 0 | 0 | Input capture register | Input capture at rising edge |
| | | | 1 | | Input capture at falling edge |
| | | 1 | 0 | | Input capture at both edges |
| | | | X | | |

[Legend]

X: Don't care

Note: * After power-on reset, 0 is output until TIOR is set.

Table 11.25 TIORL_4 (Channel 4)

| | | | | Description | |
|---------------|---------------|---------------|---------------|---|---|
| Bit 3 IOC3 | Bit 2 IOC2 | Bit 1 IOC1 | Bit 0 IOC0 | TGRC_4 Function | TIOC4C Pin Function |
| 0 | 0 | 0 | 0 | Output compare register* ² | Output retained* ¹ |
| | | | 1 | | Initial output is 0 0 output at compare match |
| | | 1 | 0 | | Initial output is 0 1 output at compare match |
| | | | 1 | | Initial output is 0 Toggle output at compare match |
| | 1 | 0 | 0 | Output retained | |
| | | | 1 | Initial output is 1 0 output at compare match | |
| | | 1 | 0 | Initial output is 1 1 output at compare match | |
| | | | 1 | Initial output is 1 Toggle output at compare match | |
| 1 | X | 0 | 0 | Input capture register* ² | Input capture at rising edge |
| | | | 1 | | Input capture at falling edge |
| | | 1 | X | | Input capture at both edges |

[Legend]

X: Don't care

- Notes:
1. After power-on reset, 0 is output until TIOR is set.
 2. When the BFA bit in TMDR_4 is set to 1 and TGRC_4 is used as a buffer register, this setting is invalid and input capture/output compare is not generated.

11.3.4 Timer Interrupt Enable Register (TIER)

The TIER registers are 8-bit readable/writable registers that control enabling or disabling of interrupt requests for each channel. The MTU has five TIER registers, one for each channel.

| Bit | Bit Name | Initial Value | R/W | Description |
|-----|----------|---------------|-----|--|
| 7 | TTGE | 0 | R/W | <p>A/D Conversion Start Request Enable</p> <p>Enables or disables generation of A/D conversion start requests by TGRA input capture/compare match.</p> <p>0: A/D conversion start request generation disabled 1: A/D conversion start request generation enabled</p> |
| 6 | — | 1 | R | <p>Reserved</p> <p>This bit is always read as 1. The write value should always be 1.</p> |
| 5 | TCIEU | 0 | R/W | <p>Underflow Interrupt Enable</p> <p>Enables or disables interrupt requests (TCIU) by the TCFU flag when the TCFU flag in TSR is set to 1 in channels 1 and 2.</p> <p>In channels 0, 3, and 4, bit 5 is reserved. It is always read as 0 and the write value should always be 0.</p> <p>0: Interrupt requests (TCIU) by TCFU disabled 1: Interrupt requests (TCIU) by TCFU enabled</p> |
| 4 | TCIEV | 0 | R/W | <p>Overflow Interrupt Enable</p> <p>Enables or disables interrupt requests (TCIV) by the TCFV flag when the TCFV flag in TSR is set to 1.</p> <p>0: Interrupt requests (TCIV) by TCFV disabled 1: Interrupt requests (TCIV) by TCFV enabled</p> |
| 3 | TGIED | 0 | R/W | <p>TGR Interrupt Enable D</p> <p>Enables or disables interrupt requests (TGID) by the TGFD bit when the TGFD bit in TSR is set to 1 in channels 0, 3, and 4.</p> <p>In channels 1 and 2, bit 3 is reserved. It is always read as 0 and the write value should always be 0.</p> <p>0: Interrupt requests (TGID) by TGFD bit disabled 1: Interrupt requests (TGID) by TGFD bit enabled</p> |

| Bit | Bit Name | Initial Value | R/W | Description |
|-----|----------|---------------|-----|--|
| 2 | TGIEC | 0 | R/W | <p>TGR Interrupt Enable C</p> <p>Enables or disables interrupt requests (TGIC) by the TGFC bit when the TGFC bit in TSR is set to 1 in channels 0, 3, and 4.</p> <p>In channels 1 and 2, bit 2 is reserved. It is always read as 0 and the write value should always be 0.</p> <p>0: Interrupt requests (TGIC) by TGFC bit disabled 1: Interrupt requests (TGIC) by TGFC bit enabled</p> |
| 1 | TGIEB | 0 | R/W | <p>TGR Interrupt Enable B</p> <p>Enables or disables interrupt requests (TGIB) by the TGFB bit when the TGFB bit in TSR is set to 1.</p> <p>0: Interrupt requests (TGIB) by TGFB bit disabled 1: Interrupt requests (TGIB) by TGFB bit enabled</p> |
| 0 | TGIEA | 0 | R/W | <p>TGR Interrupt Enable A</p> <p>Enables or disables interrupt requests (TGIA) by the TGFA bit when the TGFA bit in TSR is set to 1.</p> <p>0: Interrupt requests (TGIA) by TGFA bit disabled 1: Interrupt requests (TGIA) by TGFA bit enabled</p> |

11.3.5 Timer Status Register (TSR)

The TSR registers are 8-bit readable/writable registers that indicate the status of each channel. The MTU has five TSR registers, one for each channel.

| Bit | Bit Name | Initial Value | R/W | Description |
|-----|----------|---------------|--------|--|
| 7 | TCFD | 1 | R | <p>Count Direction Flag</p> <p>Status flag that shows the direction in which TCNT counts in channels 1, 2, 3, and 4.</p> <p>In channel 0, bit 7 is reserved. It is always read as 1 and the write value should always be 1.</p> <p>0: TCNT counts down 1: TCNT counts up</p> |
| 6 | — | 1 | R | <p>Reserved</p> <p>This bit is always read as 1. The write value should always be 1.</p> |
| 5 | TCFU | 0 | R/(W)* | <p>Underflow Flag</p> <p>Status flag that indicates that TCNT underflow has occurred when channels 1 and 2 are set to phase counting mode. Only 0 can be written, for flag clearing.</p> <p>In channels 0, 3, and 4, bit 5 is reserved. It is always read as 0 and the write value should always be 0.</p> <p>[Setting condition]</p> <ul style="list-style-type: none"> When the TCNT value underflows (changes from H'0000 to H'FFFF) <p>[Clearing condition]</p> <ul style="list-style-type: none"> When 0 is written to TCFU after reading TCFU = 1 |
| 4 | TCFV | 0 | R/(W)* | <p>Overflow Flag</p> <p>Status flag that indicates that TCNT overflow has occurred. Only 0 can be written, for flag clearing.</p> <p>[Setting condition]</p> <ul style="list-style-type: none"> When the TCNT value overflows (changes from H'FFFF to H'0000) <p>In channel 4, when the TCNT_4 value underflows (changes from H'0001 to H'0000) in complementary PWM mode, this flag is also set.</p> <p>[Clearing condition]</p> <ul style="list-style-type: none"> When 0 is written to TCFV after reading TCFV = 1 <p>In channel 4, when DTC is activated by TCIV interrupt and the DISEL bit of DTMR in DTC is 0, this flag is also cleared.</p> |

| Bit | Bit Name | Initial Value | R/W | Description |
|-----|----------|---------------|--------|---|
| 3 | TGFD | 0 | R/(W)* | <p>Input Capture/Output Compare Flag D</p> <p>Status flag that indicates the occurrence of TGRD input capture or compare match in channels 0, 3, and 4. Only 0 can be written, for flag clearing. In channels 1 and 2, bit 3 is reserved. It is always read as 0 and the write value should always be 0.</p> <p>[Setting conditions]</p> <ul style="list-style-type: none"> • When TCNT = TGRD and TGRD is functioning as output compare register • When TCNT value is transferred to TGRD by input capture signal and TGRD is functioning as input capture register <p>[Clearing conditions]</p> <ul style="list-style-type: none"> • When DTC is activated by TGID interrupt and the DISEL bit of DTMR in DTC is 0 • When 0 is written to TGFD after reading TGFD = 1 |
| 2 | TGFC | 0 | R/(W)* | <p>Input Capture/Output Compare Flag C</p> <p>Status flag that indicates the occurrence of TGRC input capture or compare match in channels 0, 3, and 4. Only 0 can be written, for flag clearing. In channels 1 and 2, bit 2 is reserved. It is always read as 0 and the write value should always be 0.</p> <p>[Setting conditions]</p> <ul style="list-style-type: none"> • When TCNT = TGRC and TGRC is functioning as output compare register • When TCNT value is transferred to TGRC by input capture signal and TGRC is functioning as input capture register <p>[Clearing conditions]</p> <ul style="list-style-type: none"> • When DTC is activated by TGIC interrupt and the DISEL bit of DTMR in DTC is 0 • When 0 is written to TGFC after reading TGFC = 1 |

| Bit | Bit Name | Initial Value | R/W | Description |
|-----|----------|---------------|--------|--|
| 1 | TGFB | 0 | R/(W)* | <p>Input Capture/Output Compare Flag B</p> <p>Status flag that indicates the occurrence of TGRB input capture or compare match. Only 0 can be written, for flag clearing.</p> <p>[Setting conditions]</p> <ul style="list-style-type: none"> When TCNT = TGRB and TGRB is functioning as output compare register When TCNT value is transferred to TGRB by input capture signal and TGRB is functioning as input capture register <p>[Clearing conditions]</p> <ul style="list-style-type: none"> When DTC is activated by TGIB interrupt and the DISEL bit of DTMR in DTC is 0 When 0 is written to TGFB after reading TGFB = 1 |
| 0 | TGFA | 0 | R/(W)* | <p>Input Capture/Output Compare Flag A</p> <p>Status flag that indicates the occurrence of TGRA input capture or compare match. Only 0 can be written, for flag clearing.</p> <p>[Setting conditions]</p> <ul style="list-style-type: none"> When TCNT = TGRA and TGRA is functioning as output compare register When TCNT value is transferred to TGRA by input capture signal and TGRA is functioning as input capture register <p>[Clearing conditions]</p> <ul style="list-style-type: none"> When DTC is activated by TGIA interrupt and the DISEL bit of DTMR in DTC is 0 When 0 is written to TGFA after reading TGFA = 1 |

Note: * Only 0 can be written to clear the flag.

11.3.6 Timer Counter (TCNT)

The TCNT registers are 16-bit readable/writable counters. The MTU has five TCNT counters, one for each channel.

The TCNT counters are initialized to H'0000 by a reset.

The TCNT counters cannot be accessed in 8-bit units; they must always be accessed as a 16-bit unit.

11.3.7 Timer General Register (TGR)

The TGR registers are dual function 16-bit readable/writable registers, functioning as either output compare or input capture registers. The MTU has 16 TGR registers, four each for channels 0, 3, and 4 and two each for channels 1 and 2. TGRC and TGRD for channels 0, 3, and 4 can also be designated for operation as buffer registers. The TGR registers cannot be accessed in 8-bit units; they must always be accessed as a 16-bit unit. TGR buffer register combinations are TGRA and TGRC and TGRB and TGRD.

The initial value of TGR is H'FFFF.

11.3.8 Timer Start Register (TSTR)

TSTR is an 8-bit readable/writable register that selects operation/stoppage for channels 0 to 4. When setting the operating mode in TMDR or setting the count clock in TCR, first stop the TCNT counter.

| Bit | Bit Name | Initial Value | R/W | Description |
|--------|----------|---------------|-----|---|
| 7 | CST4 | 0 | R/W | Counter Start 4 and 3 |
| 6 | CST3 | 0 | R/W | These bits select operation or stoppage for TCNT. If 0 is written to the CST bit during operation with the TIOC pin designated for output, the counter stops but the TIOC pin output compare output level is retained. If TIOR is written to when the CST bit is cleared to 0, the pin output level will be changed to the set initial output value. 0: TCNT_4 and TCNT_3 count operation is stopped 1: TCNT_4 and TCNT_3 performs count operation |
| 5 to 3 | — | All 0 | R | Reserved These bits are always read as 0. The write value should always be 0. |
| 2 | CST2 | 0 | R/W | Counter Start 2 to 0 |
| 1 | CST1 | 0 | R/W | These bits select operation or stoppage for TCNT. |
| 0 | CST0 | 0 | R/W | If 0 is written to the CST bit during operation with the TIOC pin designated for output, the counter stops but the TIOC pin output compare output level is retained. If TIOR is written to when the CST bit is cleared to 0, the pin output level will be changed to the set initial output value. 0: TCNT_2 to TCNT_0 count operation is stopped 1: TCNT_2 to TCNT_0 performs count operation |

11.3.9 Timer Synchronous Register (TSYR)

TSYR is an 8-bit readable/writable register that selects independent operation or synchronous operation for the channel 0 to 4 TCNT counters. A channel performs synchronous operation when the corresponding bit in TSYR is set to 1.

| Bit | Bit Name | Initial Value | R/W | Description |
|--------|----------|---------------|-----|---|
| 7 | SYNC4 | 0 | R/W | Timer Synchronous operation 4 and 3 |
| 6 | SYNC3 | 0 | R/W | <p>These bits are used to select whether operation is independent of or synchronized with other channels.</p> <p>When synchronous operation is selected, the TCNT synchronous presetting of multiple channels, and synchronous clearing by counter clearing on another channel, are possible.</p> <p>To set synchronous operation, the SYNC bits for at least two channels must be set to 1. To set synchronous clearing, in addition to the SYNC bit, the TCNT clearing source must also be set by means of bits CCLR0 to CCLR2 in TCR.</p> <p>0: TCNT_4 and TCNT_3 operate independently (TCNT presetting/clearing is unrelated to other channels)</p> <p>1: TCNT_4 and TCNT_3 performs synchronous operation</p> <p>TCNT synchronous presetting/synchronous clearing is possible</p> |
| 5 to 3 | — | All 0 | R | <p>Reserved</p> <p>These bits are always read as 0. The write value should always be 0.</p> |
| 2 | SYNC2 | 0 | R/W | Timer Synchronous operation 2 to 0 |
| 1 | SYNC1 | 0 | R/W | These bits are used to select whether operation is independent of or synchronized with other channels. |
| 0 | SYNC0 | 0 | R/W | <p>When synchronous operation is selected, the TCNT synchronous presetting of multiple channels, and synchronous clearing by counter clearing on another channel, are possible.</p> <p>To set synchronous operation, the SYNC bits for at least two channels must be set to 1. To set synchronous clearing, in addition to the SYNC bit, the TCNT clearing source must also be set by means of bits CCLR0 to CCLR2 in TCR.</p> <p>0: TCNT_2 to TCNT_0 operates independently (TCNT presetting /clearing is unrelated to other channels)</p> <p>1: TCNT_2 to TCNT_0 performs synchronous operation</p> <p>TCNT synchronous presetting/synchronous clearing is possible</p> |

11.3.10 Timer Output Master Enable Register (TOER)

TOER is an 8-bit readable/writable register that enables/disables output settings for output pins TIOC4D, TIOC4C, TIOC3D, TIOC4B, TIOC4A, and TIOC3B. These pins do not output correctly if the TOER bits have not been set. Set TOER of CH3 and CH4 prior to setting TIOR of CH3 and CH4.

| Bit | Bit Name | Initial Value | R/W | Description |
|------|----------|---------------|-----|---|
| 7, 6 | — | All 1 | R | Reserved These bits are always read as 1. The write value should always be 1. |
| 5 | OE4D | 0 | R/W | Master Enable TIOC4D This bit enables/disables the TIOC4D pin MTU output. 0: MTU output is disabled 1: MTU output is enabled |
| 4 | OE4C | 0 | R/W | Master Enable TIOC4C This bit enables/disables the TIOC4C pin MTU output. 0: MTU output is disabled 1: MTU output is enabled |
| 3 | OE3D | 0 | R/W | Master Enable TIOC3D This bit enables/disables the TIOC3D pin MTU output. 0: MTU output is disabled 1: MTU output is enabled |
| 2 | OE4B | 0 | R/W | Master Enable TIOC4B This bit enables/disables the TIOC4B pin MTU output. 0: MTU output is disabled 1: MTU output is enabled |
| 1 | OE4A | 0 | R/W | Master Enable TIOC4A This bit enables/disables the TIOC4A pin MTU output. 0: MTU output is disabled 1: MTU output is enabled |
| 0 | OE3B | 0 | R/W | Master Enable TIOC3B This bit enables/disables the TIOC3B pin MTU output. 0: MTU output is disabled 1: MTU output is enabled |

11.3.11 Timer Output Control Register (TOCR)

TOCR is an 8-bit readable/writable register that enables/disables PWM synchronized toggle output in complementary PWM mode/reset synchronized PWM mode, and controls output level inversion of PWM output.

| Bit | Bit Name | Initial value | R/W | Description |
|--------|----------|---------------|-----|--|
| 7 | — | 0 | R | Reserved This bit is always read as 0. The write value should always be 0. |
| 6 | PSYE | 0 | R/W | PWM Synchronous Output Enable This bit selects the enable/disable of toggle output synchronized with the PWM period. 0: Toggle output is disabled 1: Toggle output is enabled |
| 5 to 2 | — | All 0 | R | Reserved These bits are always read as 0. The write value should always be 0. |
| 1 | OLSN | 0 | R/W | Output Level Select N This bit selects the reverse phase output level in reset-synchronized PWM mode/complementary PWM mode. See table 11.26 |
| 0 | OLSP | 0 | R/W | Output Level Select P This bit selects the positive phase output level in reset-synchronized PWM mode/complementary PWM mode. See table 11.27 |

Table 11.26 Output Level Select Function

| Bit 1 | Function | | | |
|----------|------------|----------------|--------------|----------------------|
| | OLSN | Initial Output | Active Level | Compare Match Output |
| Up Count | | | | Down Count |
| 0 | High level | Low level | High level | Low level |
| 1 | Low level | High level | Low level | High level |

Note: The reverse phase waveform initial output value changes to active level after elapse of the dead time after count start.

Table 11.27 Output Level Select Function

| Bit 0 | Function | | | |
|-------|----------------|--------------|----------------------|------------|
| | Initial Output | Active Level | Compare Match Output | |
| OLSP | Initial Output | Active Level | Up Count | Down Count |
| 0 | High level | Low level | Low level | High level |
| 1 | Low level | High level | High level | Low level |

Figure 11.2 shows an example of complementary PWM mode output (1 phase) when OLSN = 1, OLSP = 1.

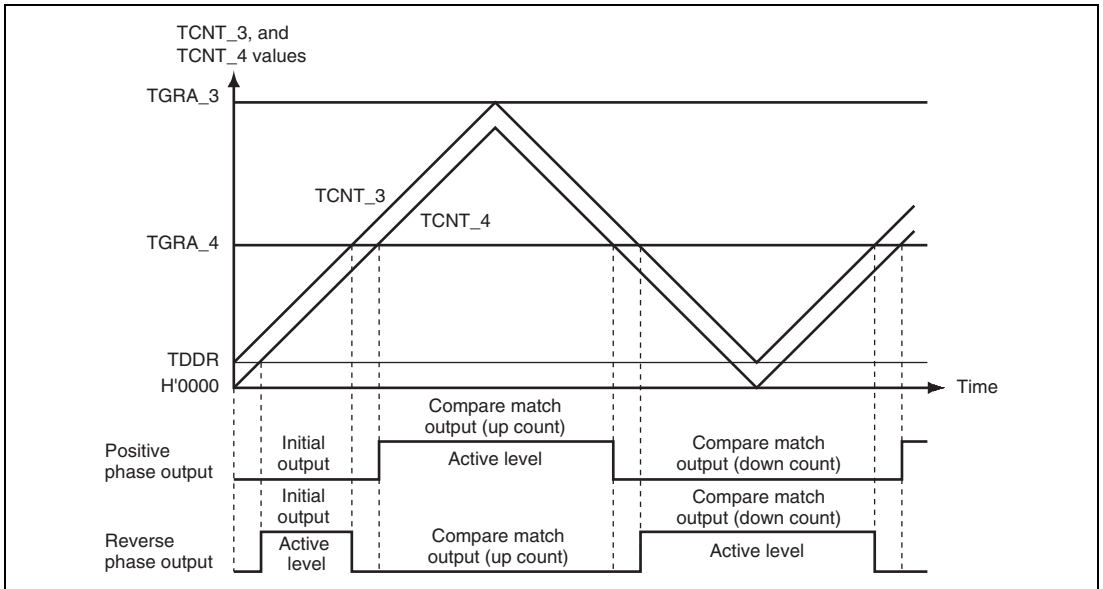

Figure 11.2 Complementary PWM Mode Output Level Example

11.3.12 Timer Gate Control Register (TGCR)

TGCR is an 8-bit readable/writable register that controls the waveform output necessary for brushless DC motor control in reset-synchronized PWM mode/complementary PWM mode. These register settings are ineffective for anything other than complementary PWM mode/reset-synchronized PWM mode.

| Bit | Bit Name | Initial value | R/W | Description |
|-----|----------|---------------|-----|--|
| 7 | — | 1 | R | Reserved This bit is always read as 1. The write value should always be 1. |
| 6 | BDC | 0 | R/W | Brushless DC Motor This bit selects whether to make the functions of this register (TGCR) effective or ineffective. 0: Ordinary output 1: Functions of this register are made effective |
| 5 | N | 0 | R/W | Reverse Phase Output (N) Control This bit selects whether the level output or the reset-synchronized PWM/complementary PWM output while the reverse pins (TIOC3D, TIOC4C, and TIOC4D) are output. 0: Level output 1: Reset synchronized PWM/complementary PWM output |
| 4 | P | 0 | R/W | Positive Phase Output (P) Control This bit selects whether the level output or the reset-synchronized PWM/complementary PWM output while the positive pin (TIOC3B, TIOC4A, and TIOC4B) are output. 0: Level output 1: Reset synchronized PWM/complementary PWM output |

| Bit | Bit Name | Initial value | R/W | Description |
|-----|----------|---------------|-----|---|
| 3 | FB | 0 | R/W | <p>External Feedback Signal Enable</p> <p>This bit selects whether the switching of the output of the positive/reverse phase is carried out automatically with the MTU/channel 0 TGRA, TGRB, TGRC input capture signals or by writing 0 or 1 to bits 2 to 0 in TGCR.</p> <p>0: Output switching is external input (Input sources are channel 0 TGRA, TGRB, TGRC input capture signal)</p> <p>1: Output switching is carried out by software (TGCR's UF, VF, WF settings).</p> |
| 2 | WF | 0 | R/W | Output Phase Switch 2 to 0 |
| 1 | VF | 0 | R/W | These bits set the positive phase/negative phase output phase on or off state. The setting of these bits is valid only when the FB bit in this register is set to 1. In this case, the setting of bits 2 to 0 is a substitute for external input. See table 11.28. |
| 0 | UF | 0 | R/W | |

Table 11.28 Output level Select Function

| Bit 2 | Bit 1 | Bit 0 | Function | | | | | |
|-------|-------|-------|----------|---------|---------|---------|---------|---------|
| | | | TIOC3B | TIOC4A | TIOC4B | TIOC3D | TIOC4C | TIOC4D |
| WF | VF | UF | U Phase | V Phase | W Phase | U Phase | V Phase | W Phase |
| 0 | 0 | 0 | OFF | OFF | OFF | OFF | OFF | OFF |
| | | 1 | ON | OFF | OFF | OFF | OFF | ON |
| | 1 | 0 | OFF | ON | OFF | ON | OFF | OFF |
| | | 1 | OFF | ON | OFF | OFF | OFF | ON |
| 1 | 0 | 0 | OFF | OFF | ON | OFF | ON | OFF |
| | | 1 | ON | OFF | OFF | OFF | ON | OFF |
| | 1 | 0 | OFF | OFF | ON | ON | OFF | OFF |
| | | 1 | OFF | OFF | OFF | OFF | OFF | OFF |

11.3.13 Timer Subcounter (TCNTS)

TCNTS is a 16-bit read-only counter that is used only in complementary PWM mode.

The initial value of TCNTS is H'0000.

Note: Accessing the TCNTS in 8-bit units is prohibited. Always access in 16-bit units.

11.3.14 Timer Dead Time Data Register (TDDR)

TDDR is a 16-bit register, used only in complementary PWM mode, that specifies the TCNT_3 and TCNT_4 counter offset values. In complementary PWM mode, when the TCNT_3 and TCNT_4 counters are cleared and then restarted, the TDDR register value is loaded into the TCNT_3 counter and the count operation starts.

The initial value of TDDR is H'FFFF.

Note: Accessing the TDDR in 8-bit units is prohibited. Always access in 16-bit units.

11.3.15 Timer Period Data Register (TCDR)

TCDR is a 16-bit register used only in complementary PWM mode. Set half the PWM carrier sync value as the TCDR register value. This register is constantly compared with the TCNTS counter in complementary PWM mode, and when a match occurs, the TCNTS counter switches direction (decrement to increment).

The initial value of TCDR is H'FFFF.

Note: Accessing the TCDR in 8-bit units is prohibited. Always access in 16-bit units.

11.3.16 Timer Period Buffer Register (TCBR)

The timer period buffer register (TCBR) is a 16-bit register used only in complementary PWM mode. It functions as a buffer register for the TCDR register. The TCBR register values are transferred to the TCDR register with the transfer timing set in the TMDR register.

Note: Accessing the TCBR in 8-bit units is prohibited. Always access in 16-bit units.

11.3.17 Bus Master Interface

The timer counters (TCNT), general registers (TGR), timer subcounter (TCNTS), timer period buffer register (TCBR), and timer dead time data register (TDDR), and timer period data register (TCDR) are 16-bit registers. A 16-bit data bus to the bus master enables 16-bit read/writes. 8-bit read/write is not possible. Always access in 16-bit units.

All registers other than the above registers are 8-bit registers. These are connected to the CPU by a 16-bit data bus, so 16-bit read/writes and 8-bit read/writes are both possible.

11.4 Operation

11.4.1 Basic Functions

Each channel has a TCNT and TGR register. TCNT performs up-counting, and is also capable of free-running operation, synchronous counting, and external event counting.

Each TGR can be used as an input capture register or output compare register.

Always select MTU external pins set function using the pin function controller (PFC).

Counter Operation:

When one of bits CST0 to CST4 is set to 1 in TSTR, the TCNT counter for the corresponding channel begins counting. TCNT can operate as a free-running counter, periodic counter, for example.

1. Example of Count Operation Setting Procedure

Figure 11.3 shows an example of the count operation setting procedure.

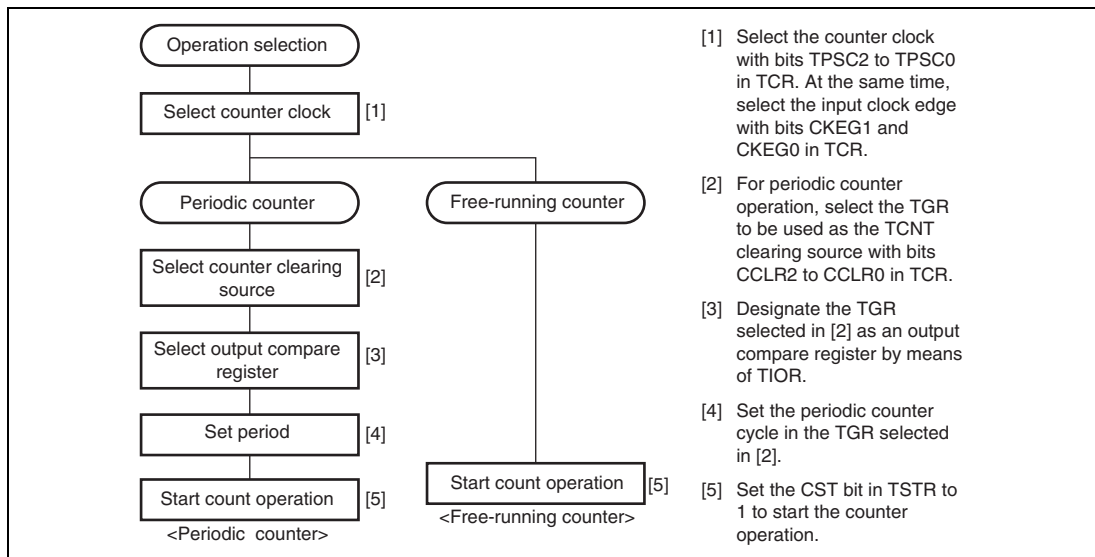

Figure 11.3 Example of Counter Operation Setting Procedure

2. Free-Running Count Operation and Periodic Count Operation:

Immediately after a reset, the MTU's TCNT counters are all designated as free-running counters. When the relevant bit in TSTR is set to 1 the corresponding TCNT counter starts up-count operation as a free-running counter. When TCNT overflows (from H'FFFF to H'0000), the TCFV bit in TSR is set to 1. If the value of the corresponding TCIEV bit in TIER is 1 at this point, the TPU requests an interrupt. After overflow, TCNT starts counting up again from H'0000.

Figure 11.4 illustrates free-running counter operation.

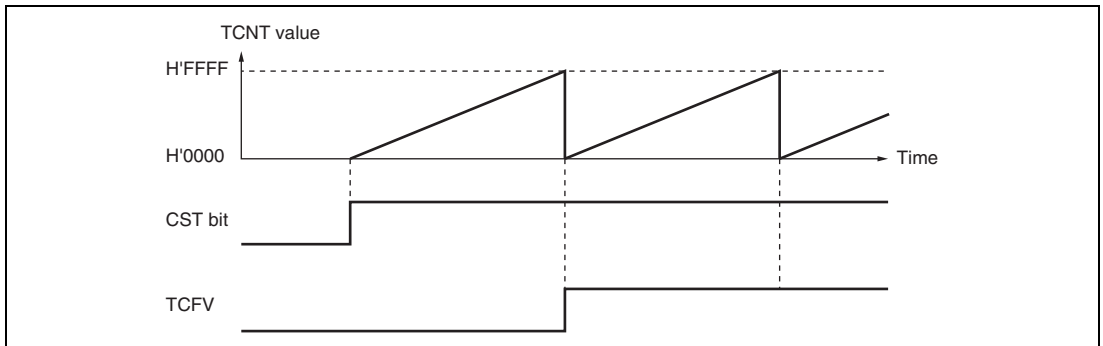

Figure 11.4 Free-Running Counter Operation

When compare match is selected as the TCNT clearing source, the TCNT counter for the relevant channel performs periodic count operation. The TGR register for setting the period is designated as an output compare register, and counter clearing by compare match is selected by means of bits CCLR0 to CCLR2 in TCR. After the settings have been made, TCNT starts up-count operation as a periodic counter when the corresponding bit in TSTR is set to 1. When the count value matches the value in TGR, the TGF bit in TSR is set to 1 and TCNT is cleared to H'0000.

If the value of the corresponding TGIE bit in TIER is 1 at this point, the TPU requests an interrupt. After a compare match, TCNT starts counting up again from H'0000.

Figure 11.5 illustrates periodic counter operation.

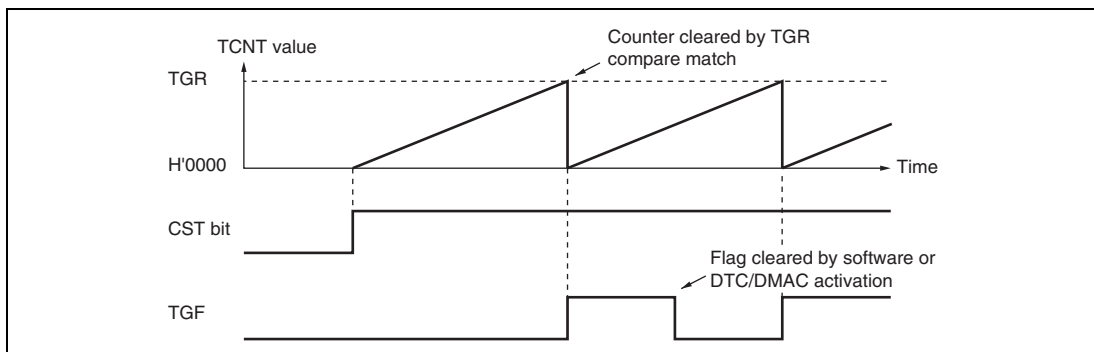

Figure 11.5 Periodic Counter Operation

Waveform Output by Compare Match:

The MTU can perform 0, 1, or toggle output from the corresponding output pin using compare match.

1. Example of Setting Procedure for Waveform Output by Compare Match

Figure 11.6 shows an example of the setting procedure for waveform output by compare match

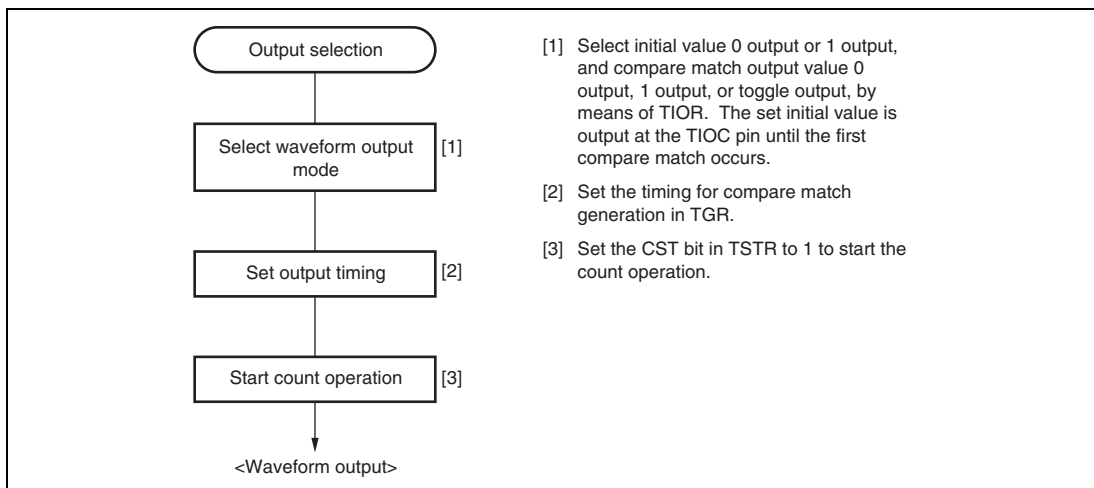

Figure 11.6 Example of Setting Procedure for Waveform Output by Compare Match

2. Examples of Waveform Output Operation:

Figure 11.7 shows an example of 0 output/1 output.

In this example TCNT has been designated as a free-running counter, and settings have been made such that 1 is output by compare match A, and 0 is output by compare match B. When the set level and the pin level coincide, the pin level does not change.

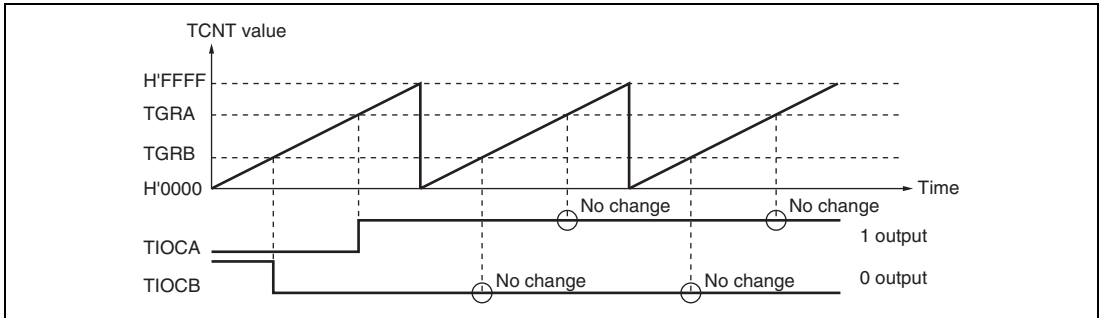

Figure 11.7 Example of 0 Output/1 Output Operation

Figure 11.8 shows an example of toggle output.

In this example, TCNT has been designated as a periodic counter (with counter clearing on compare match B), and settings have been made such that the output is toggled by both compare match A and compare match B.

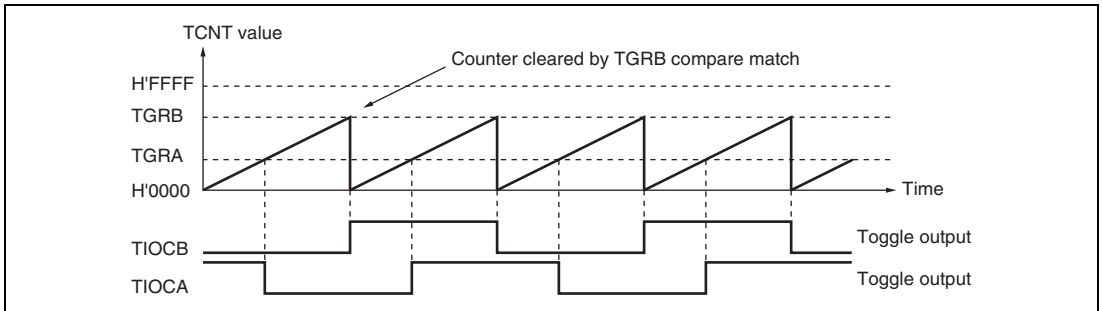

Figure 11.8 Example of Toggle Output Operation

Input Capture Function:

The TCNT value can be transferred to TGR on detection of the TIOC pin input edge.

Rising edge, falling edge, or both edges can be selected as the detected edge. For channels 0 and 1, it is also possible to specify another channel's counter input clock or compare match signal as the input capture source.

Note: When another channel's counter input clock is used as the input capture input for channels 0 and 1, P ϕ /1 should not be selected as the counter input clock used for input capture input. Input capture will not be generated if P ϕ /1 is selected.

1. Example of Input Capture Operation Setting Procedure

Figure 11.9 shows an example of the input capture operation setting procedure.

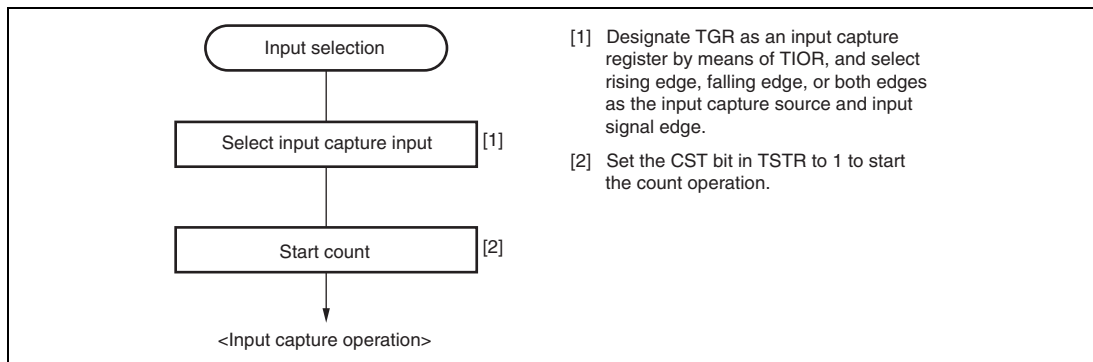

Figure 11.9 Example of Input Capture Operation Setting Procedure

2. Example of Input Capture Operation:

Figure 11.10 shows an example of input capture operation.

In this example both rising and falling edges have been selected as the TIOCA pin input capture input edge, the falling edge has been selected as the TIOCB pin input capture input edge, and counter clearing by TGRB input capture has been designated for TCNT.

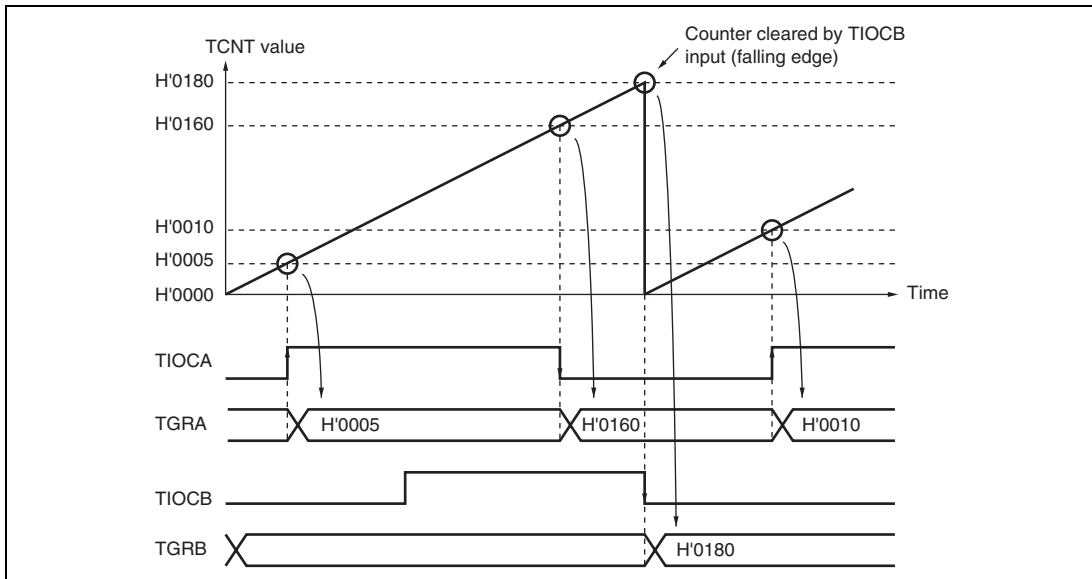

Figure 11.10 Example of Input Capture Operation

11.4.2 Synchronous Operation

In synchronous operation, the values in a number of TCNT counters can be rewritten simultaneously (synchronous presetting). Also, a number of TCNT counters can be cleared simultaneously by making the appropriate setting in TCR (synchronous clearing).

Synchronous operation enables TGR to be incremented with respect to a single time base.

Channels 0 to 4 can all be designated for synchronous operation.

Example of Synchronous Operation Setting Procedure:

Figure 11.11 shows an example of the synchronous operation setting procedure.

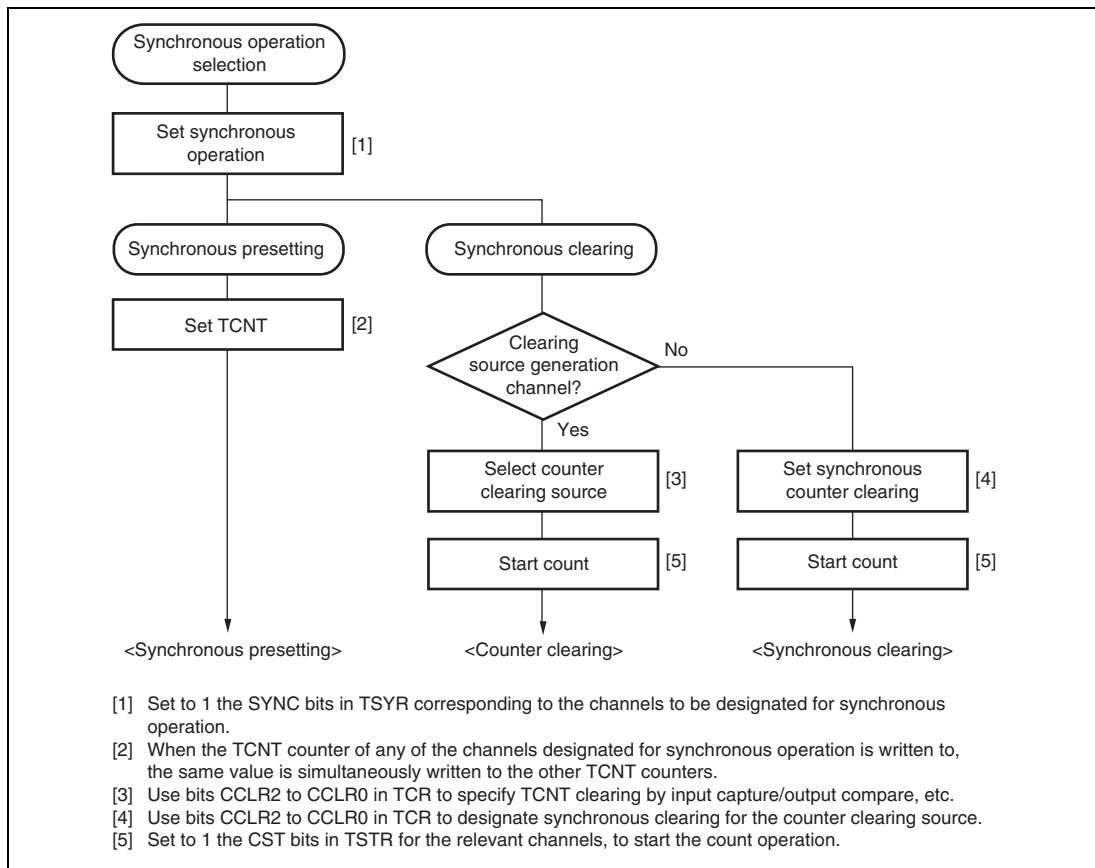

Figure 11.11 Example of Synchronous Operation Setting Procedure

Example of Synchronous Operation: Figure 11.12 shows an example of synchronous operation.

In this example, synchronous operation and PWM mode 1 have been designated for channels 0 to 2, TGRB_0 compare match has been set as the channel 0 counter clearing source, and synchronous clearing has been set for the channel 1 and 2 counter clearing source.

Three-phase PWM waveforms are output from pins TIOC0A, TIOC1A, and TIOC2A. At this time, synchronous presetting, and synchronous clearing by TGRB_0 compare match, are performed for channel 0 to 2 TCNT counters, and the data set in TGRB_0 is used as the PWM cycle.

For details of PWM modes, see section 11.4.5, PWM Modes.

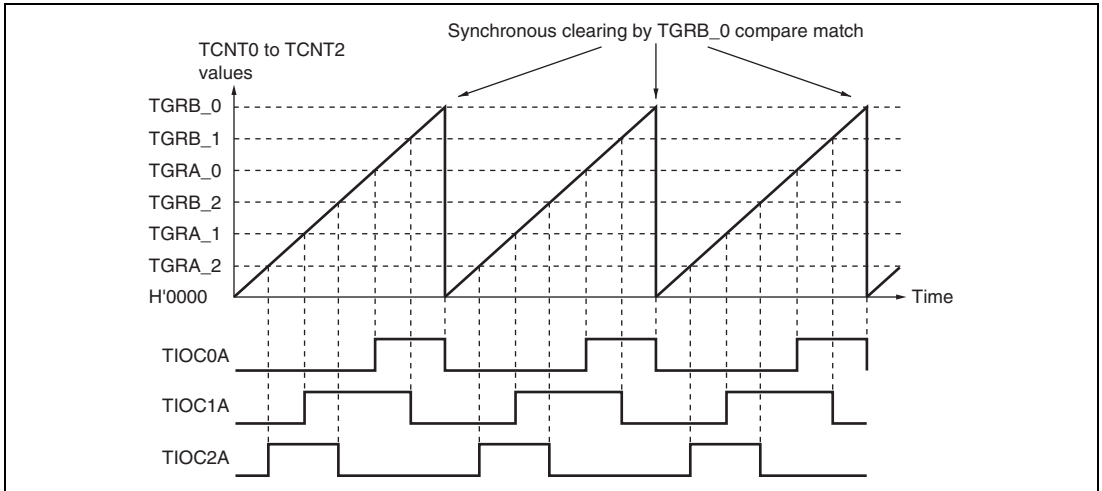

Figure 11.12 Example of Synchronous Operation

11.4.3 Buffer Operation

Buffer operation, provided for channels 0, 3, and 4, enables TGR_C and TGR_D to be used as buffer registers.

Buffer operation differs depending on whether TGR has been designated as an input capture register or as a compare match register.

Table 11.29 shows the register combinations used in buffer operation.

Table 11.29 Register Combinations in Buffer Operation

| Channel | Timer General Register | Buffer Register |
|---------|------------------------|-----------------|
| 0 | TGRA_0 | TGRC_0 |
| | TGRB_0 | TGRD_0 |
| 3 | TGRA_3 | TGRC_3 |
| | TGRB_3 | TGRD_3 |
| 4 | TGRA_4 | TGRC_4 |
| | TGRB_4 | TGRD_4 |

- When TGR is an output compare register

When a compare match occurs, the value in the buffer register for the corresponding channel is transferred to the timer general register.

This operation is illustrated in figure 11.13.

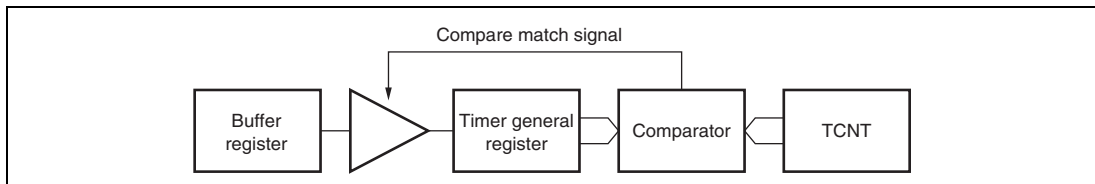

Figure 11.13 Compare Match Buffer Operation

- When TGR is an input capture register

When input capture occurs, the value in TCNT is transferred to TGR and the value previously held in the timer general register is transferred to the buffer register.

This operation is illustrated in figure 11.14.

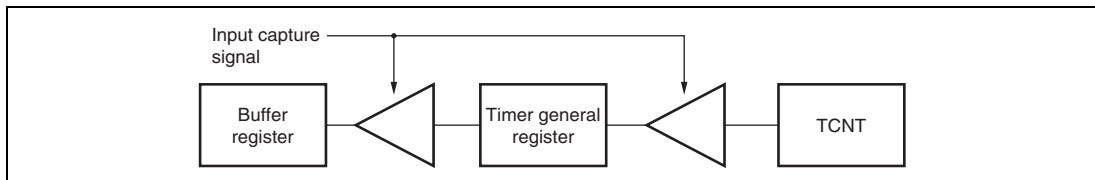

Figure 11.14 Input Capture Buffer Operation

Example of Buffer Operation Setting Procedure: Figure 11.15 shows an example of the buffer operation setting procedure.

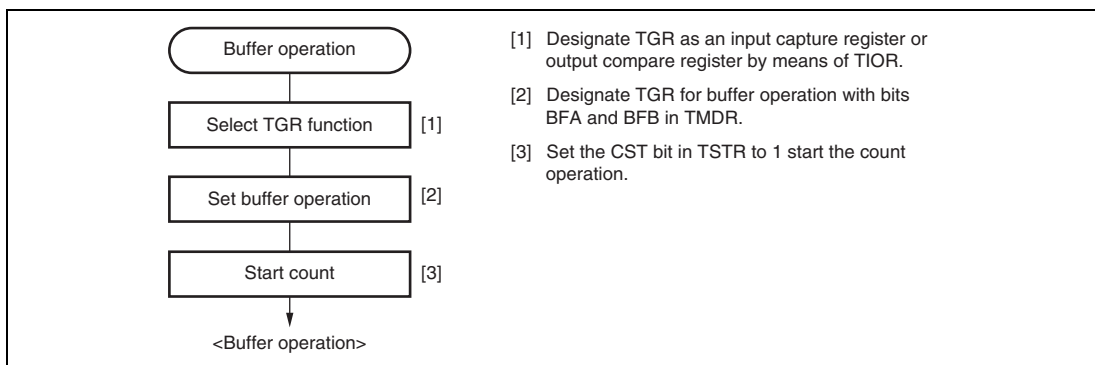

Figure 11.15 Example of Buffer Operation Setting Procedure

Examples of Buffer Operation:

1. When TGR is an output compare register

Figure 11.16 shows an operation example in which PWM mode 1 has been designated for channel 0, and buffer operation has been designated for TGRA and TGRC. The settings used in this example are TCNT clearing by compare match B, 1 output at compare match A, and 0 output at compare match B.

As buffer operation has been set, when compare match A occurs the output changes and the value in buffer register TGRC is simultaneously transferred to timer general register TGRA. This operation is repeated each time that compare match A occurs.

For details of PWM modes, see section 11.4.5, PWM Modes.

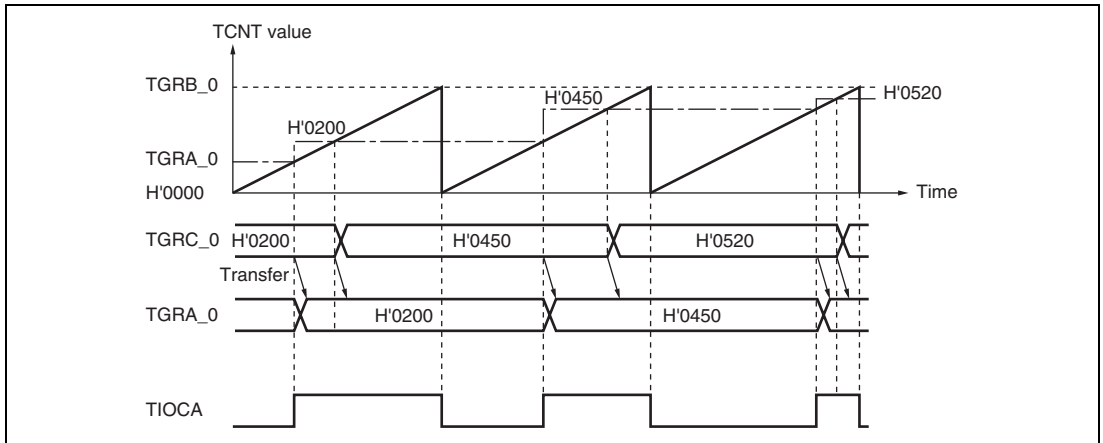

Figure 11.16 Example of Buffer Operation (1)

2. When TGR is an input capture register

Figure 11.17 shows an operation example in which TGRA has been designated as an input capture register, and buffer operation has been designated for TGRA and TGRC.

Counter clearing by TGRA input capture has been set for TCNT, and both rising and falling edges have been selected as the TIOCA pin input capture input edge.

As buffer operation has been set, when the TCNT value is stored in TGRA upon the occurrence of input capture A, the value previously stored in TGRA is simultaneously transferred to TGRC.

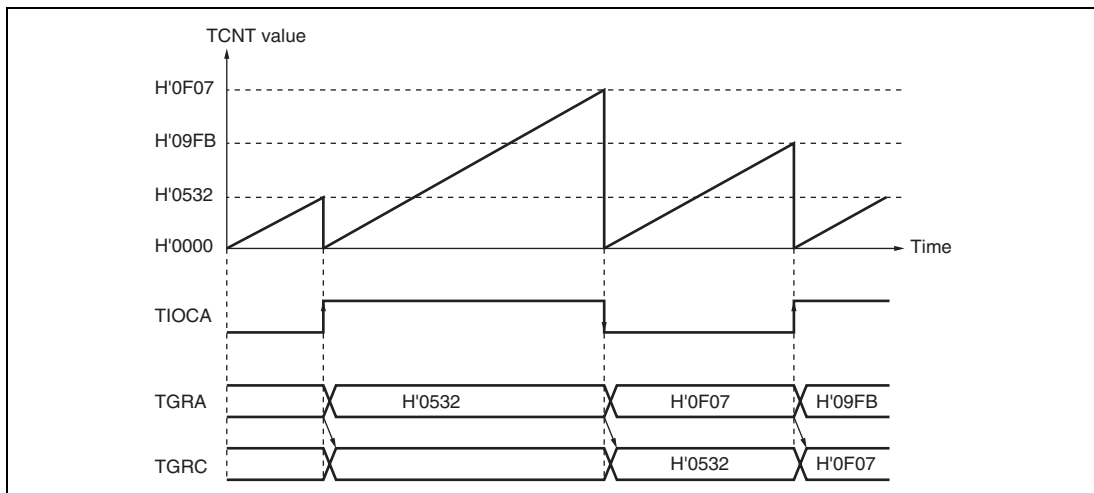

Figure 11.17 Example of Buffer Operation (2)

11.4.4 Cascaded Operation

In cascaded operation, two 16-bit counters for different channels are used together as a 32-bit counter.

This function works by counting the channel 1 counter clock upon overflow/underflow of TCNT_2 as set in bits TPSC0 to TPSC2 in TCR.

Underflow occurs only when the lower 16-bit TCNT is in phase-counting mode.

Table 11.30 shows the register combinations used in cascaded operation.

Note: When phase counting mode is set for channel 1, the counter clock setting is invalid and the counters operate independently in phase counting mode.

Table 11.30 Cascaded Combinations

| Combination | Upper 16 Bits | Lower 16 Bits |
|------------------|---------------|---------------|
| Channels 1 and 2 | TCNT_1 | TCNT_2 |

Example of Cascaded Operation Setting Procedure: Figure 11.18 shows an example of the setting procedure for cascaded operation.

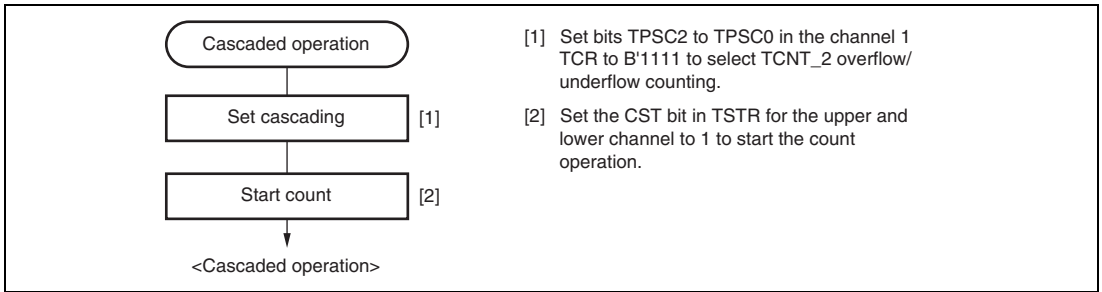

Figure 11.18 Cascaded Operation Setting Procedure

Examples of Cascaded Operation: Figure 11.19 illustrates the operation when TCNT_2 overflow/underflow counting has been set for TCNT_1 and phase counting mode has been designated for channel 2.

TCNT_1 is incremented by TCNT_2 overflow and decremented by TCNT_2 underflow.

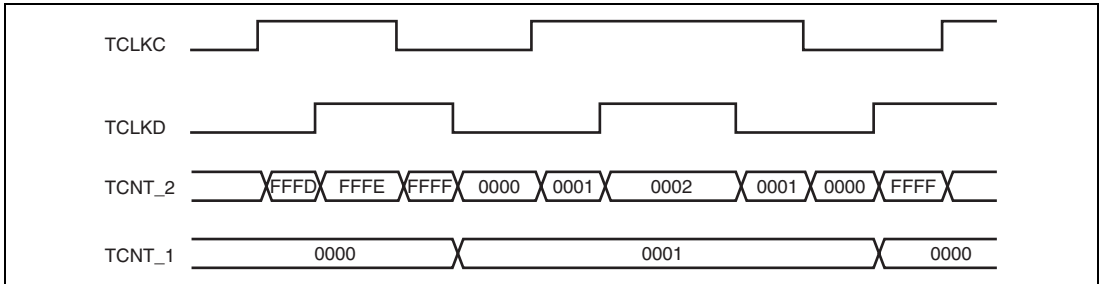

Figure 11.19 Example of Cascaded Operation

11.4.5 PWM Modes

In PWM mode, PWM waveforms are output from the output pins. The output level can be selected as 0, 1, or toggle output in response to a compare match of each TGR.

TGR registers settings can be used to output a PWM waveform in the range of 0% to 100% duty.

Designating TGR compare match as the counter clearing source enables the period to be set in that register. All channels can be designated for PWM mode independently. Synchronous operation is also possible.

There are two PWM modes, as described below.

1. PWM mode 1

PWM output is generated from the TIOCA and TIOCC pins by pairing TGRA with TGRB and TGRC with TGRD. The output specified by bits IOA0 to IOA3 and IOC0 to IOC3 in TIOR is output from the TIOCA and TIOCC pins at compare matches A and C, and the output specified by bits IOB0 to IOB3 and IOD0 to IOD3 in TIOR is output at compare matches B and D. The initial output value is the value set in TGRA or TGRC. If the set values of paired TGRs are identical, the output value does not change when a compare match occurs.

In PWM mode 1, a maximum 8-phase PWM output is possible.

2. PWM mode 2

PWM output is generated using one TGR as the cycle register and the others as duty registers. The output specified in TIOR is performed by means of compare matches. Upon counter clearing by a synchronization register compare match, the output value of each pin is the initial value set in TIOR. If the set values of the cycle and duty registers are identical, the output value does not change when a compare match occurs.

In PWM mode 2, a maximum 8-phase PWM output is possible in combination use with synchronous operation.

The correspondence between PWM output pins and registers is shown in table 11.31.

Table 11.31 PWM Output Registers and Output Pins

| Channel | Registers | Output Pins | |
|---------|-----------|-------------|---------------|
| | | PWM Mode 1 | PWM Mode 2 |
| 0 | TGRA_0 | TIOC0A | TIOC0A |
| | TGRB_0 | | TIOC0B |
| | TGRC_0 | TIOC0C | TIOC0C |
| | TGRD_0 | | TIOC0D |
| 1 | TGRA_1 | TIOC1A | TIOC1A |
| | TGRB_1 | | TIOC1B |
| 2 | TGRA_2 | TIOC2A | TIOC2A |
| | TGRB_2 | | TIOC2B |
| 3 | TGRA_3 | TIOC3A | Cannot be set |
| | TGRB_3 | | Cannot be set |
| | TGRC_3 | TIOC3C | Cannot be set |
| | TGRD_3 | | Cannot be set |
| 4 | TGRA_4 | TIOC4A | Cannot be set |
| | TGRB_4 | | Cannot be set |
| | TGRC_4 | TIOC4C | Cannot be set |
| | TGRD_4 | | Cannot be set |

Note: In PWM mode 2, PWM output is not possible for the TGR register in which the period is set.

Example of PWM Mode Setting Procedure: Figure 11.20 shows an example of the PWM mode setting procedure.

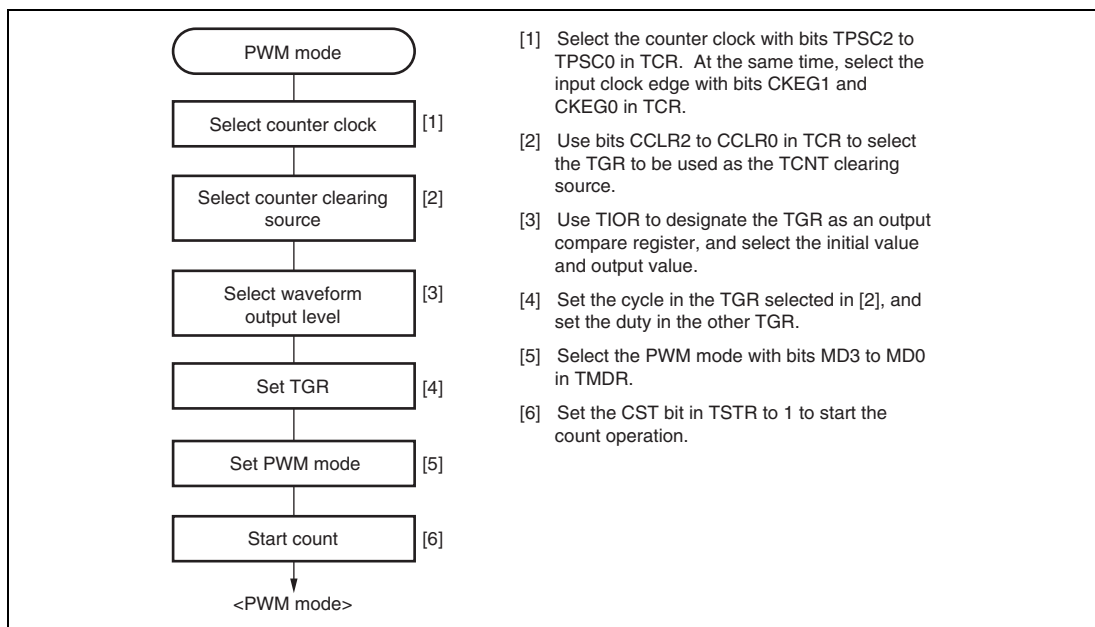

Figure 11.20 Example of PWM Mode Setting Procedure

Examples of PWM Mode Operation: Figure 11.21 shows an example of PWM mode 1 operation.

In this example, TGRA compare match is set as the TCNT clearing source, 0 is set for the TGRA initial output value and output value, and 1 is set as the TGRB output value.

In this case, the value set in TGRA is used as the period, and the values set in the TGRB registers are used as the duty levels.

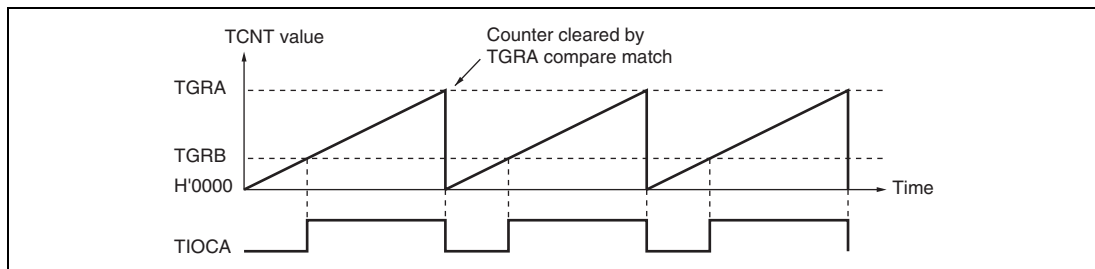

Figure 11.21 Example of PWM Mode Operation (1)

Figure 11.22 shows an example of PWM mode 2 operation.

In this example, synchronous operation is designated for channels 0 and 1, TGRB_1 compare match is set as the TCNT clearing source, and 0 is set for the initial output value and 1 for the output value of the other TGR registers (TGRA_0 to TGRD_0, TGRA_1), outputting a 5-phase PWM waveform.

In this case, the value set in TGRB_1 is used as the cycle, and the values set in the other TGRs are used as the duty levels.

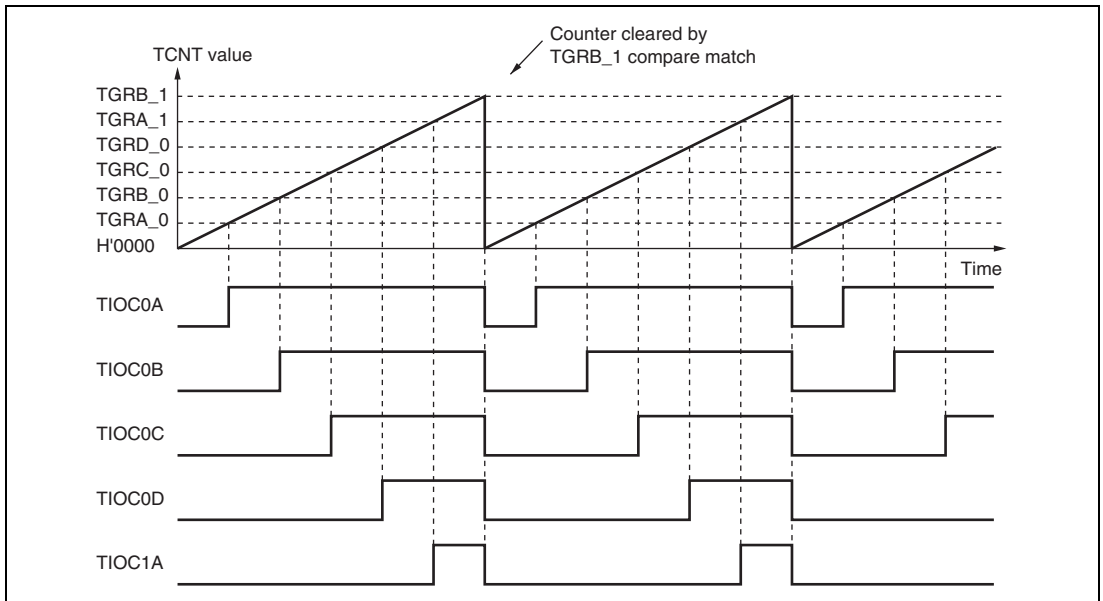

Figure 11.22 Example of PWM Mode Operation (2)

Figure 11.23 shows examples of PWM waveform output with 0% duty and 100% duty in PWM mode.

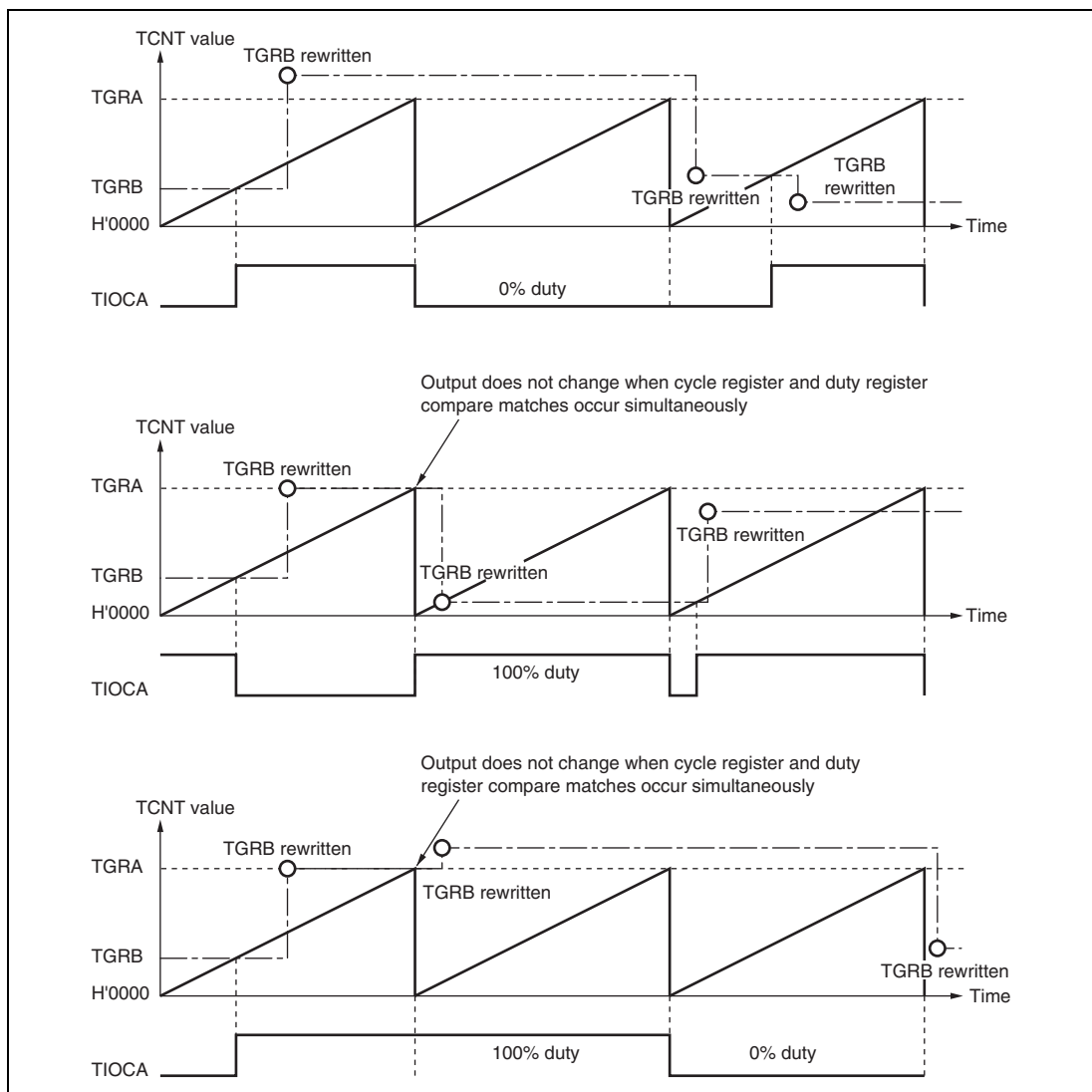

Figure 11.23 Example of PWM Mode Operation (3)

11.4.6 Phase Counting Mode

In phase counting mode, the phase difference between two external clock inputs is detected and TCNT is incremented/decremented accordingly. This mode can be set for channels 1 and 2.

When phase counting mode is set, an external clock is selected as the counter input clock and TCNT operates as an up/down-counter regardless of the setting of bits TPSC0 to TPSC2 and bits CKEG0 and CKEG1 in TCR. However, the functions of bits CCLR0 and CCLR1 in TCR, and of TIOR, TIER, and TGR, are valid, and input capture/compare match and interrupt functions can be used.

This can be used for two-phase encoder pulse input.

If overflow occurs when TCNT is counting up, the TCFV flag in TSR is set; if underflow occurs when TCNT is counting down, the TCFU flag is set.

The TCFD bit in TSR is the count direction flag. Reading the TCFD flag reveals whether TCNT is counting up or down.

Table 11.32 shows the correspondence between external clock pins and channels.

Table 11.32 Phase Counting Mode Clock Input Pins

| Channels | External Clock Pins | |
|--|---------------------|---------|
| | A-Phase | B-Phase |
| When channel 1 is set to phase counting mode | TCLKA | TCLKB |
| When channel 2 is set to phase counting mode | TCLKC | TCLKD |

Example of Phase Counting Mode Setting Procedure: Figure 11.24 shows an example of the phase counting mode setting procedure.

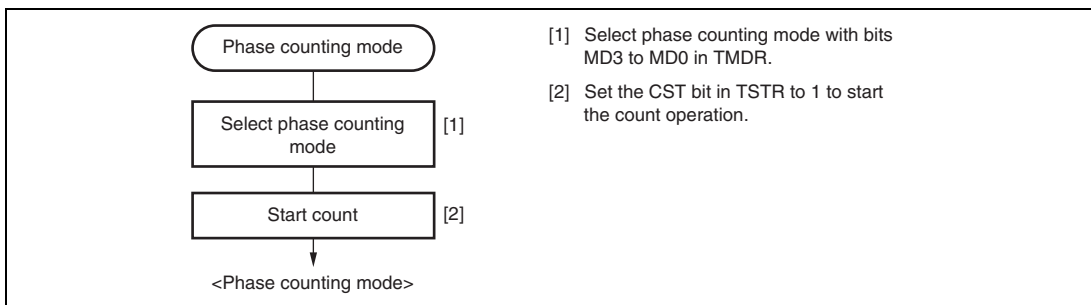

Figure 11.24 Example of Phase Counting Mode Setting Procedure

Examples of Phase Counting Mode Operation: In phase counting mode, TCNT counts up or down according to the phase difference between two external clocks. There are four modes, according to the count conditions.

1. Phase counting mode 1

Figure 11.25 shows an example of phase counting mode 1 operation, and table 11.33 summarizes the TCNT up/down-count conditions.

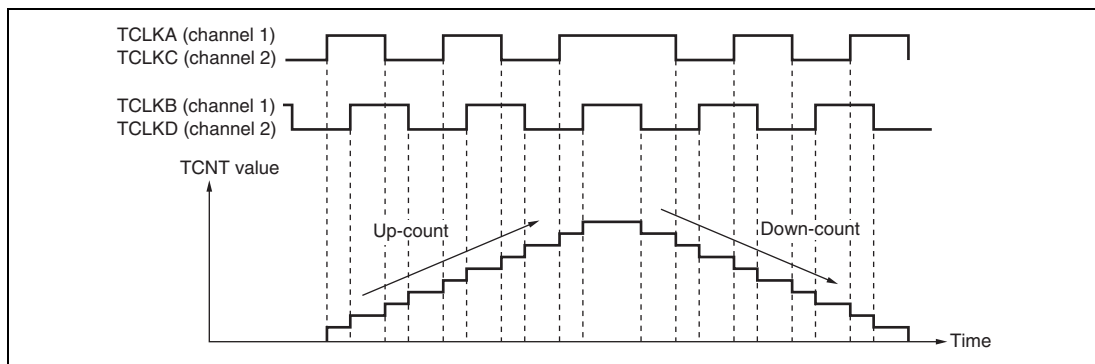

Figure 11.25 Example of Phase Counting Mode 1 Operation

Table 11.33 Up/Down-Count Conditions in Phase Counting Mode 1

| TCLKA (Channel 1) TCLKC (Channel 2) | TCLKB (Channel 1) TCLKD (Channel 2) | Operation |
|--|--|------------|
| High level | | Up-count |
| Low level | | |
| | Low level | |
| | High level | |
| High level | | Down-count |
| Low level | | |
| | High level | |
| | Low level | |

[Legend]

: Rising edge

: Falling edge

2. Phase counting mode 2

Figure 11.26 shows an example of phase counting mode 2 operation, and table 11.34 summarizes the TCNT up/down-count conditions.

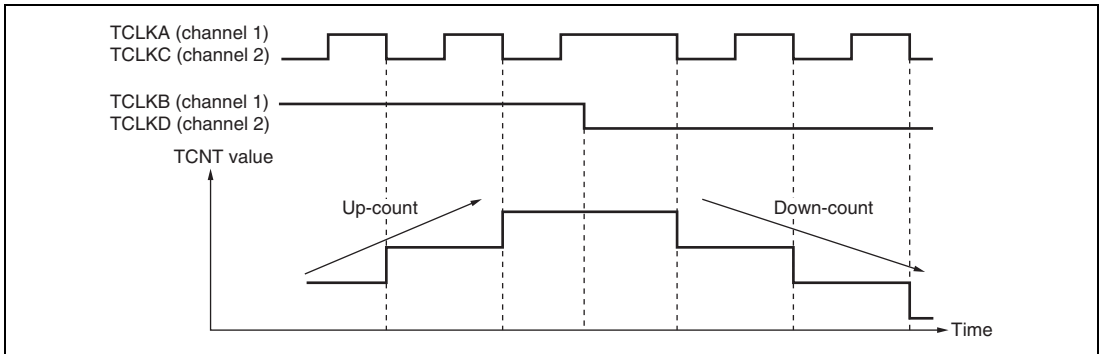

Figure 11.26 Example of Phase Counting Mode 2 Operation

Table 11.34 Up/Down-Count Conditions in Phase Counting Mode 2

| TCLKA (Channel 1) TCLKC (Channel 2) | TCLKB (Channel 1) TCLKD (Channel 2) | Operation |
|--|--|------------|
| High level | | Don't care |
| Low level | | Don't care |
| | Low level | Don't care |
| | High level | Up-count |
| High level | | Don't care |
| Low level | | Don't care |
| | High level | Don't care |
| | Low level | Down-count |

[Legend]

: Rising edge

: Falling edge

3. Phase counting mode 3

Figure 11.27 shows an example of phase counting mode 3 operation, and table 11.35 summarizes the TCNT up/down-count conditions.

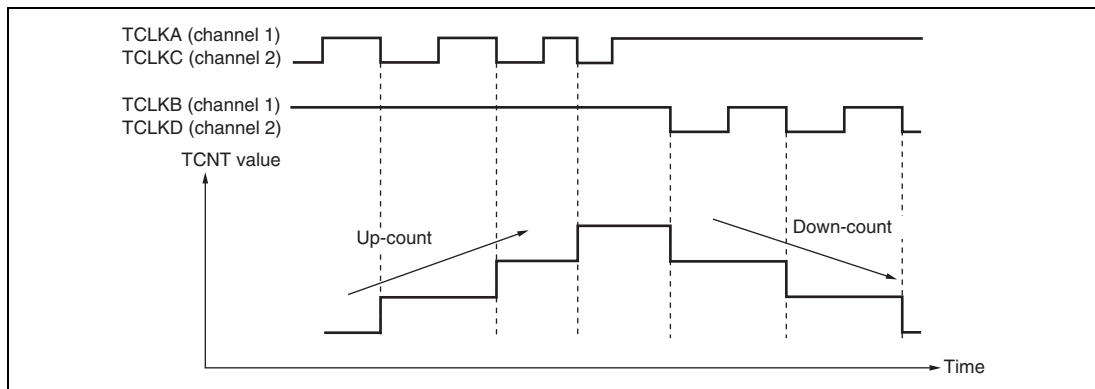

Figure 11.27 Example of Phase Counting Mode 3 Operation

Table 11.35 Up/Down-Count Conditions in Phase Counting Mode 3

| TCLKA (Channel 1) TCLKC (Channel 2) | TCLKB (Channel 1) TCLKD (Channel 2) | Operation |
|--|--|------------|
| High level | | Don't care |
| Low level | | Don't care |
| | Low level | Don't care |
| | High level | Up-count |
| High level | | Down-count |
| Low level | | Don't care |
| | High level | Don't care |
| | Low level | Don't care |

[Legend]

: Rising edge

: Falling edge

4. Phase counting mode 4

Figure 11.28 shows an example of phase counting mode 4 operation, and table 11.36 summarizes the TCNT up/down-count conditions.

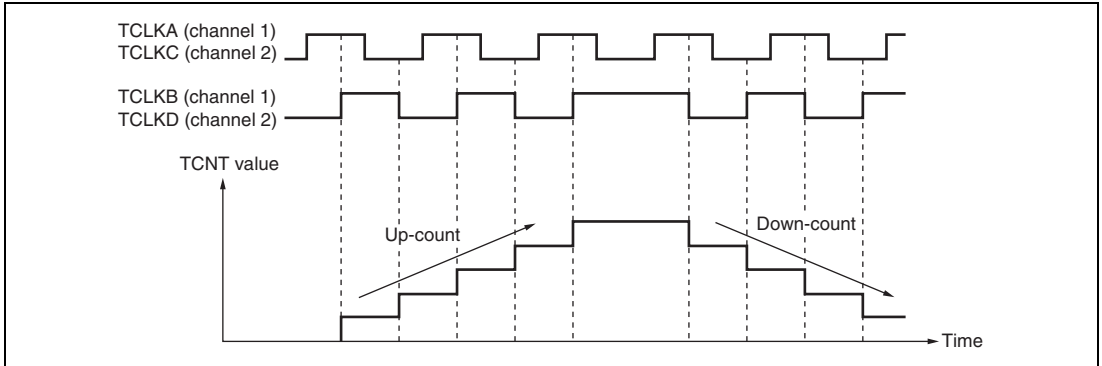

Figure 11.28 Example of Phase Counting Mode 4 Operation

Table 11.36 Up/Down-Count Conditions in Phase Counting Mode 4

| TCLKA (Channel 1) TCLKC (Channel 2) | TCLKB (Channel 1) TCLKD (Channel 2) | Operation |
|--|--|------------|
| High level | | Up-count |
| Low level | | Up-count |
| | Low level | Don't care |
| | High level | Don't care |
| High level | | Down-count |
| Low level | | Down-count |
| | High level | Don't care |
| | Low level | Don't care |

[Legend]

: Rising edge

: Falling edge

Phase Counting Mode Application Example: Figure 11.29 shows an example in which channel 1 is in phase counting mode, and channel 1 is coupled with channel 0 to input servo motor 2-phase encoder pulses in order to detect position or speed.

Channel 1 is set to phase counting mode 1, and the encoder pulse A-phase and B-phase are input to TCLKA and TCLKB.

Channel 0 operates with TCNT counter clearing by TGRC_0 compare match; TGRA_0 and TGRC_0 are used for the compare match function and are set with the speed control period and position control period. TGRB_0 is used for input capture, with TGRB_0 and TGRD_0 operating in buffer mode. The channel 1 counter input clock is designated as the TGRB_0 input capture source, and the pulse widths of 2-phase encoder 4-multiplication pulses are detected.

TGRA_1 and TGRB_1 for channel 1 are designated for input capture, and channel 0 TGRA_0 and TGRC_0 compare matches are selected as the input capture source and store the up/down-counter values for the control periods.

This procedure enables the accurate detection of position and speed.

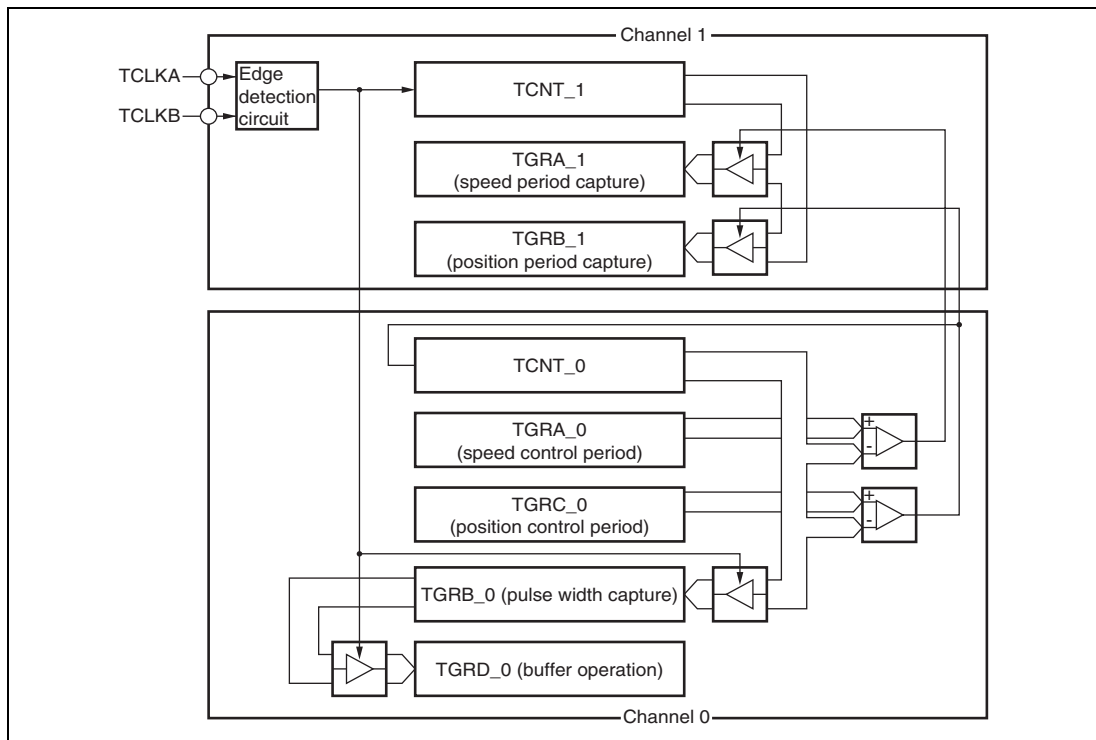

Figure 11.29 Phase Counting Mode Application Example

11.4.7 Reset-Synchronized PWM Mode

In the reset-synchronized PWM mode, three-phase output of positive and negative PWM waveforms that share a common wave transition point can be obtained by combining channels 3 and 4.

When set for reset-synchronized PWM mode, the TIOC3B, TIOC3D, TIOC4A, TIOC4C, TIOC4B, and TIOC4D pins function as PWM output pins and TCNT3 functions as an upcounter.

Table 11.37 shows the PWM output pins used. Table 11.38 shows the settings of the registers.

Table 11.37 Output Pins for Reset-Synchronized PWM Mode

| Channel | Output Pin | Description |
|---------|------------|---|
| 3 | TIOC3B | PWM output pin 1 |
| | TIOC3D | PWM output pin 1' (negative-phase waveform of PWM output 1) |
| 4 | TIOC4A | PWM output pin 2 |
| | TIOC4C | PWM output pin 2' (negative-phase waveform of PWM output 2) |
| | TIOC4B | PWM output pin 3 |
| | TIOC4D | PWM output pin 3' (negative-phase waveform of PWM output 3) |

Table 11.38 Register Settings for Reset-Synchronized PWM Mode

| Register | Description of Setting |
|----------|--|
| TCNT_3 | Initial setting of H'0000 |
| TCNT_4 | Initial setting of H'0000 |
| TGRA_3 | Set count cycle for TCNT_3 |
| TGRB_3 | Sets the turning point for PWM waveform output by the TIOC3B and TIOC3D pins |
| TGRA_4 | Sets the turning point for PWM waveform output by the TIOC4A and TIOC4C pins |
| TGRB_4 | Sets the turning point for PWM waveform output by the TIOC4B and TIOC4D pins |

Procedure for Selecting the Reset-Synchronized PWM Mode: Figure 11.30 shows an example of procedure for selecting the reset synchronized PWM mode.

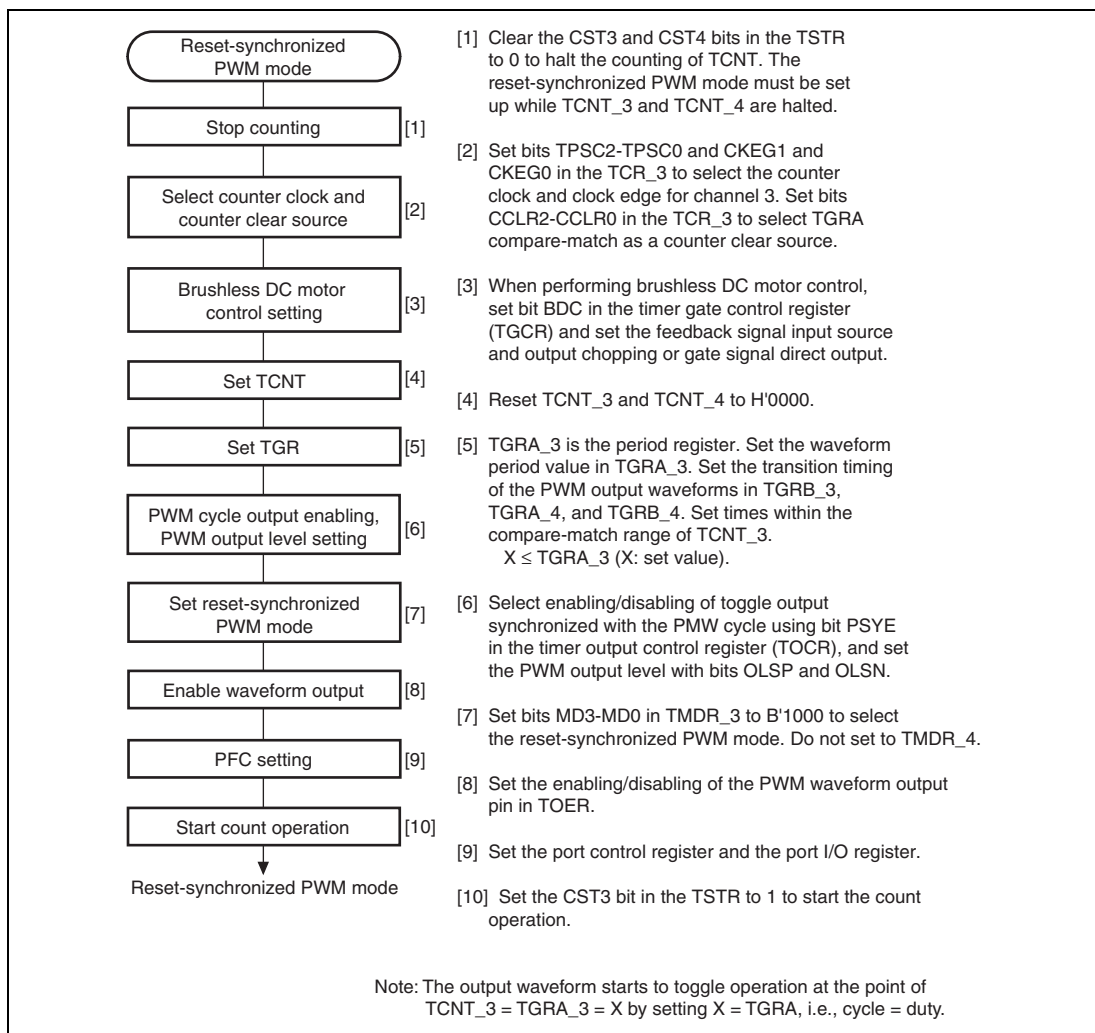

Figure 11.30 Procedure for Selecting Reset-Synchronized PWM Mode

Reset-Synchronized PWM Mode Operation: Figure 11.31 shows an example of operation in the reset-synchronized PWM mode. TCNT_3 and TCNT_4 operate as upcounters. The counter is cleared when a TCNT_3 and TGRA_3 compare-match occurs, and then begins incrementing from H'0000. The PWM output pin output toggles with each occurrence of a TGRB_3, TGRA_4, TGRB_4 compare-match, and upon counter clears.

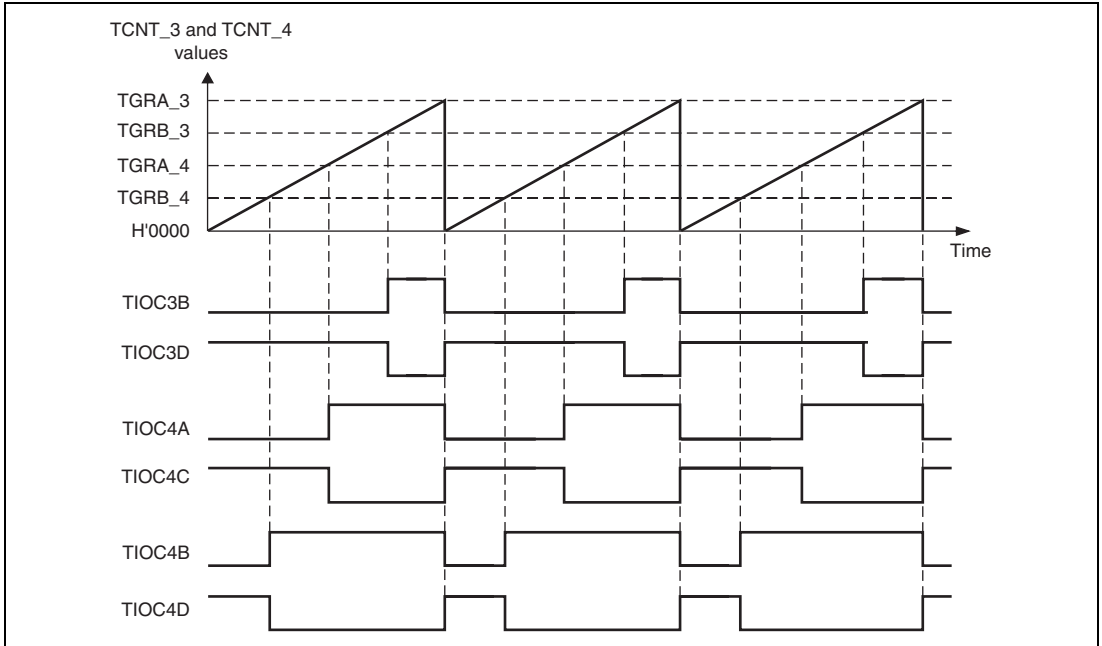

Figure 11.31 Reset-Synchronized PWM Mode Operation Example
(When TOCR's OLSN = 1 and OLSP = 1)

11.4.8 Complementary PWM Mode

In the complementary PWM mode, three-phase output of non-overlapping positive and negative PWM waveforms can be obtained by combining channels 3 and 4.

In complementary PWM mode, TIOC3B, TIOC3D, TIOC4A, TIOC4B, TIOC4C, and TIOC4D pins function as PWM output pins, the TIOC3A pin can be set for toggle output synchronized with the PWM period. TCNT_3 and TCNT_4 function as up/down counters.

Table 11.39 shows the PWM output pins used. Table 11.40 shows the settings of the registers used.

A function to directly cut off the PWM output by using an external signal is supported as a port function.

Table 11.39 Output Pins for Complementary PWM Mode

| Channel | Output Pin | Description |
|---------|------------|---|
| 3 | TIOC3A | Toggle output synchronized with PWM period (or I/O port) |
| | TIOC3B | PWM output pin 1 |
| | TIOC3C | I/O port* |
| | TIOC3D | PWM output pin 1 (non-overlapping negative-phase waveform of PWM output 1) |
| 4 | TIOC4A | PWM output pin 2 |
| | TIOC4B | PWM output pin 3 |
| | TIOC4C | PWM output pin 2 (non-overlapping negative-phase waveform of PWM output 2) |
| | TIOC4D | PWM output pin 3 (non-overlapping negative-phase waveform of PWM output 3) |

Note: * Avoid setting the TIOC3C pin as a timer I/O pin in the complementary PWM mode.

Table 11.40 Register Settings for Complementary PWM Mode

| Channel | Counter/Register | Description | Read/Write from CPU |
|--------------------------------------|------------------|--|-------------------------------|
| 3 | TCNT_3 | Start of up-count from value set in dead time register | Maskable by BSC/BCR1 setting* |
| | TGRA_3 | Set TCNT_3 upper limit value (1/2 carrier cycle + dead time) | Maskable by BSC/BCR1 setting* |
| | TGRB_3 | PWM output 1 compare register | Maskable by BSC/BCR1 setting* |
| | TGRC_3 | TGRA_3 buffer register | Always readable/writable |
| | TGRD_3 | PWM output 1/TGRB_3 buffer register | Always readable/writable |
| 4 | TCNT_4 | Up-count start, initialized to H'0000 | Maskable by BSC/BCR1 setting* |
| | TGRA_4 | PWM output 2 compare register | Maskable by BSC/BCR1 setting* |
| | TGRB_4 | PWM output 3 compare register | Maskable by BSC/BCR1 setting* |
| | TGRC_4 | PWM output 2/TGRA_4 buffer register | Always readable/writable |
| | TGRD_4 | PWM output 3/TGRB_4 buffer register | Always readable/writable |
| Timer dead time data register (TDDR) | | Set TCNT_4 and TCNT_3 offset value (dead time value) | Maskable by BSC/BCR1 setting* |
| Timer cycle data register (TCDR) | | Set TCNT_4 upper limit value (1/2 carrier cycle) | Maskable by BSC/BCR1 setting* |
| Timer cycle buffer register (TCBR) | | TCDR buffer register | Always readable/writable |
| Subcounter (TCNTS) | | Subcounter for dead time generation | Read-only |
| Temporary register 1 (TEMP1) | | PWM output 1/TGRB_3 temporary register | Not readable/writable |
| Temporary register 2 (TEMP2) | | PWM output 2/TGRA_4 temporary register | Not readable/writable |
| Temporary register 3 (TEMP3) | | PWM output 3/TGRB_4 temporary register | Not readable/writable |

Note: * Access can be enabled or disabled according to the setting of bit 13 (MTURWE) in BSC/BCR1 (bus controller/bus control register 1).

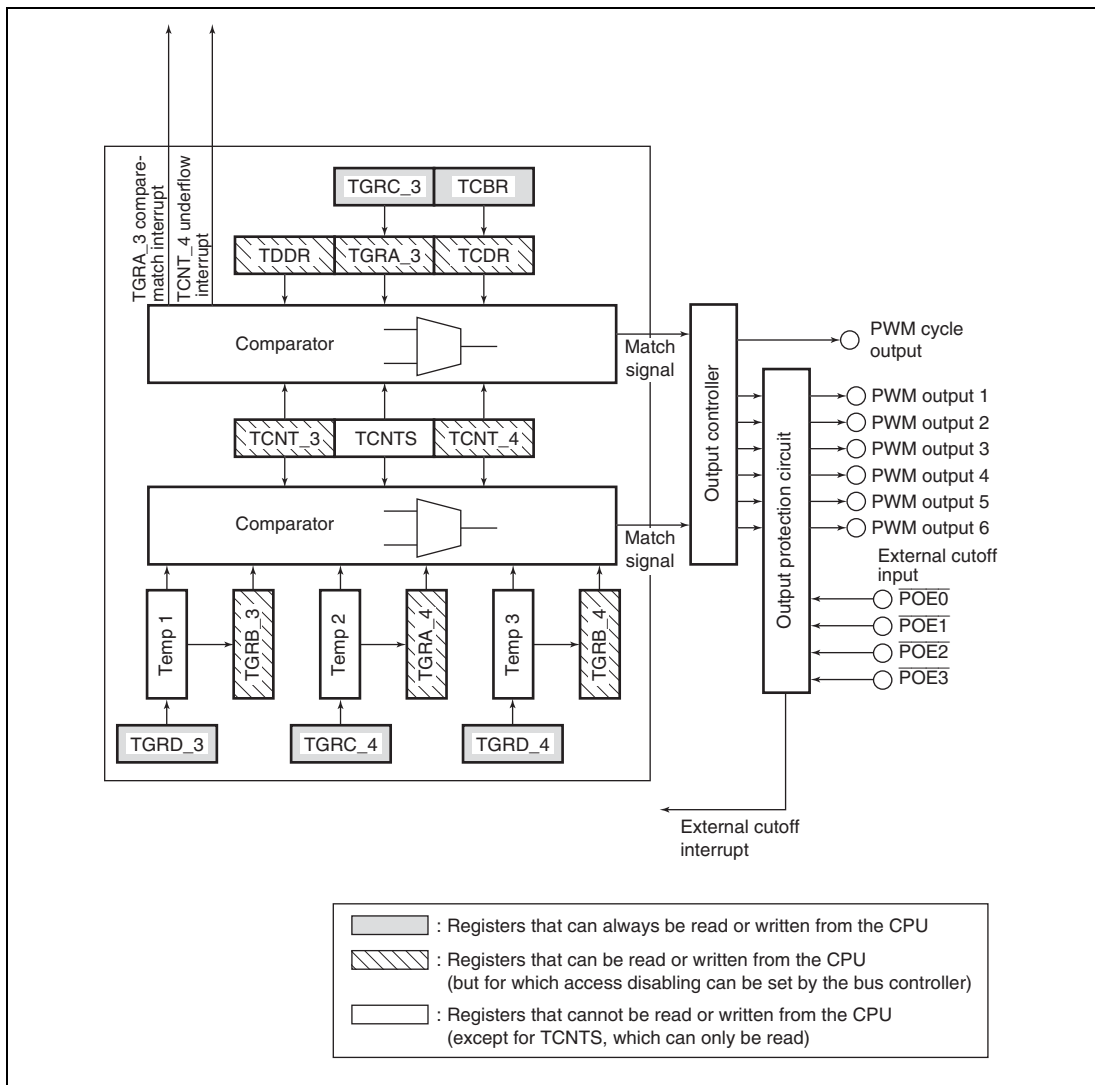

Figure 11.32 Block Diagram of Channels 3 and 4 in Complementary PWM Mode

Example of Complementary PWM Mode Setting Procedure: An example of the complementary PWM mode setting procedure is shown in figure 11.33.

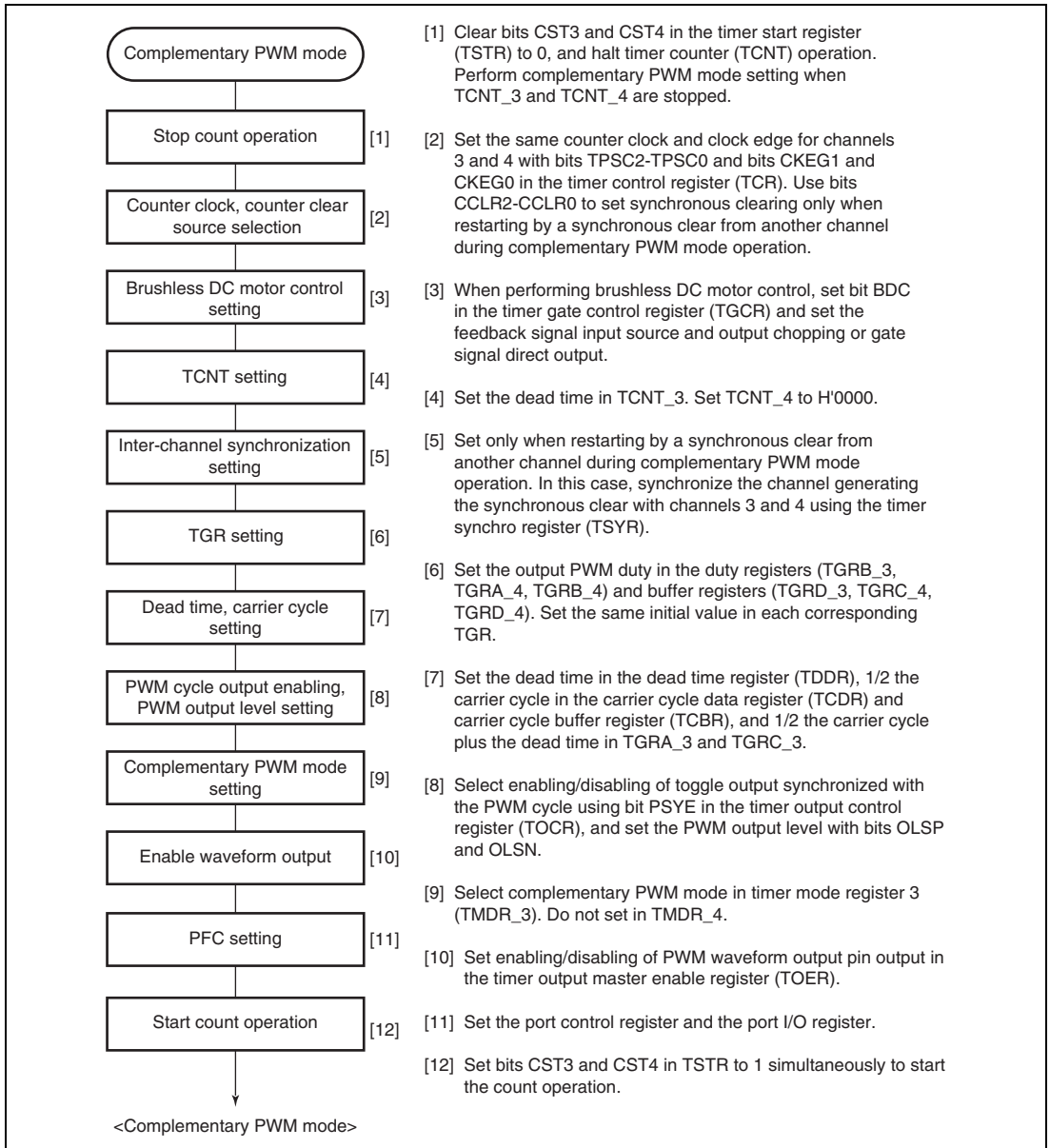

Figure 11.33 Example of Complementary PWM Mode Setting Procedure

Outline of Complementary PWM Mode Operation:

In complementary PWM mode, 6-phase PWM output is possible. Figure 11.34 illustrates counter operation in complementary PWM mode, and figure 11.35 shows an example of complementary PWM mode operation.

1. Counter Operation

In complementary PWM mode, three counters—TCNT_3, TCNT_4, and TCNTS—perform up/down-count operations.

TCNT_3 is automatically initialized to the value set in TDDR when complementary PWM mode is selected and the CST bit in TSTR is 0.

When the CST bit is set to 1, TCNT_3 counts up to the value set in TGRA_3, then switches to down-counting when it matches TGRA_3. When the TCNT3 value matches TDDR, the counter switches to up-counting, and the operation is repeated in this way.

TCNT_4 is initialized to H'0000.

When the CST bit is set to 1, TCNT4 counts up in synchronization with TCNT_3, and switches to down-counting when it matches TCDR. On reaching H'0000, TCNT4 switches to up-counting, and the operation is repeated in this way.

TCNTS is a read-only counter. It need not be initialized.

When TCNT_3 matches TCDR during TCNT_3 and TCNT_4 up/down-counting, down-counting is started, and when TCNTS matches TCDR, the operation switches to up-counting. When TCNTS matches TGRA_3, it is cleared to H'0000.

When TCNT_4 matches TDDR during TCNT_3 and TCNT_4 down-counting, up-counting is started, and when TCNTS matches TDDR, the operation switches to down-counting. When TCNTS reaches H'0000, it is set with the value in TGRA_3.

TCNTS is compared with the compare register and temporary register in which the PWM duty is set during the count operation only.

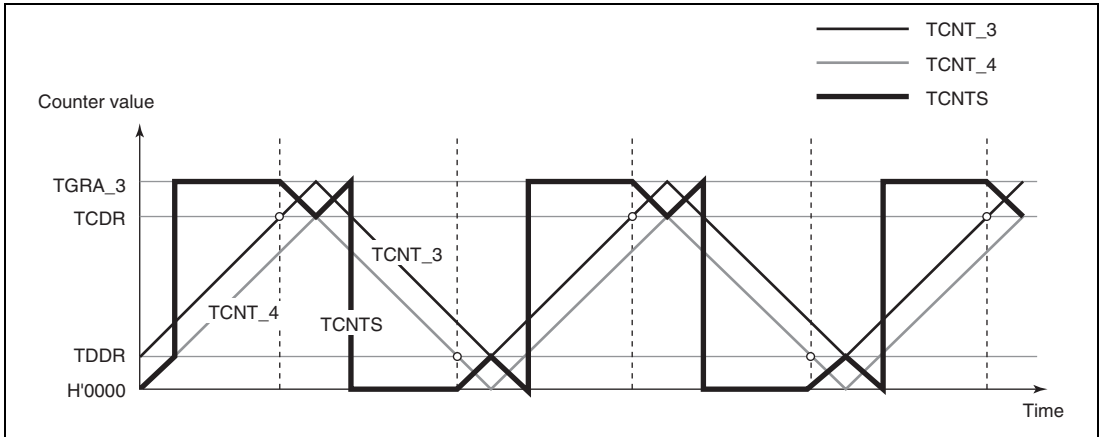

Figure 11.34 Complementary PWM Mode Counter Operation

2. Register Operation:

In complementary PWM mode, nine registers are used, comprising compare registers, buffer registers, and temporary registers. Figure 11.35 shows an example of complementary PWM mode operation.

The registers which are constantly compared with the counters to perform PWM output are TGRB_3, TGRA_4, and TGRB_4. When these registers match the counter, the value set in bits OLSN and OLSP in the timer output control register (TOCR) is output.

The buffer registers for these compare registers are TGRD_3, TGRC_4, and TGRD_4.

Between a buffer register and compare register there is a temporary register. The temporary registers cannot be accessed by the CPU.

Data in a compare register is changed by writing the new data to the corresponding buffer register. The buffer registers can be read or written at any time.

The data written to a buffer register is constantly transferred to the temporary register in the Ta interval. Data is not transferred to the temporary register in the Tb interval. Data written to a buffer register in this interval is transferred to the temporary register at the end of the Tb interval.

The value transferred to a temporary register is transferred to the compare register when TCNTS for which the Tb interval ends matches TGRA_3 when counting up, or H'0000 when counting down. The timing for transfer from the temporary register to the compare register can be selected with bits MD3 to MD0 in the timer mode register (TMDR). Figure 11.35 shows an example in which the mode is selected in which the change is made in the trough.

In the tb interval (tb1 in figure 11.35) in which data transfer to the temporary register is not performed, the temporary register has the same function as the compare register, and is compared with the counter. In this interval, therefore, there are two compare match registers for one-phase output, with the compare register containing the pre-change data, and the temporary register containing the new data. In this interval, the three counters—TCNT_3, TCNT_4, and TCNTS—and two registers—compare register and temporary register—are compared, and PWM output controlled accordingly.

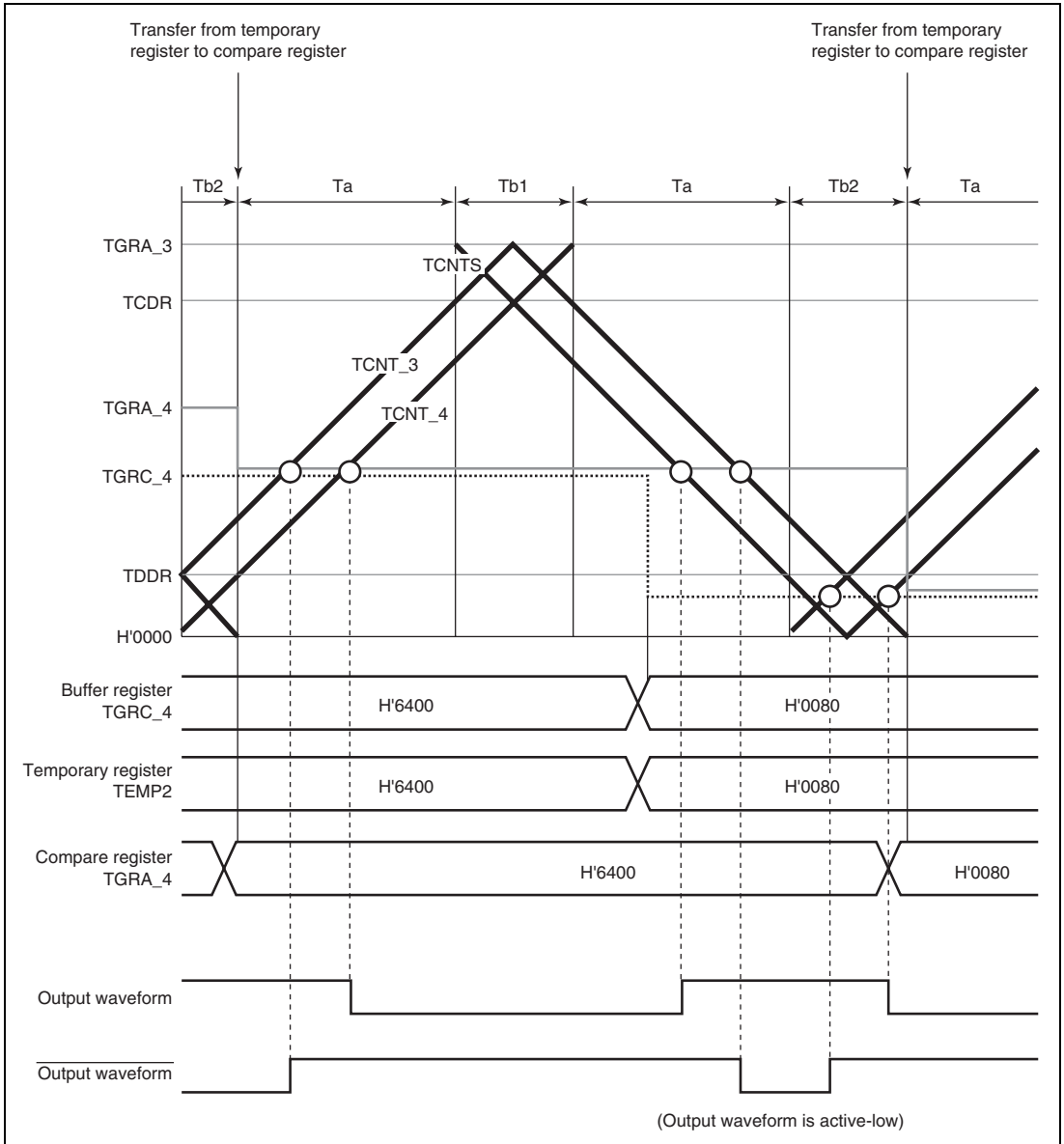

Figure 11.35 Example of Complementary PWM Mode Operation

3. Initialization

In complementary PWM mode, there are six registers that must be initialized.

Before setting complementary PWM mode with bits MD3 to MD0 in the timer mode register (TMDR), the following initial register values must be set.

TGRC_3 operates as the buffer register for TGRA_3, and should be set with 1/2 the PWM carrier cycle + dead time Td. The timer cycle buffer register (TCBR) operates as the buffer register for the timer cycle data register (TCDR), and should be set with 1/2 the PWM carrier cycle. Set dead time Td in the timer dead time data register (TDDR).

Set the respective initial PWM duty values in buffer registers TGRD_3, TGRC_4, and TGRD_4.

The values set in the five buffer registers excluding TDDR are transferred simultaneously to the corresponding compare registers when complementary PWM mode is set.

Set TCNT_4 to H'0000 before setting complementary PWM mode.

Table 11.41 Registers and Counters Requiring Initialization

| Register/Counter | Set Value |
|------------------------|---------------------------------------|
| TGRC_3 | 1/2 PWM carrier cycle + dead time Td |
| TDDR | Dead time Td |
| TCBR | 1/2 PWM carrier cycle |
| TGRD_3, TGRC_4, TGRD_4 | Initial PWM duty value for each phase |
| TCNT_4 | H'0000 |

Note: The TGRC_3 set value must be the sum of 1/2 the PWM carrier cycle set in TCBR and dead time Td set in TDDR.

4. PWM Output Level Setting

In complementary PWM mode, the PWM pulse output level is set with bits OLSN and OLSP in the timer output control register (TOCR).

The output level can be set for each of the three positive phases and three negative phases of 6-phase output.

Complementary PWM mode should be cleared before setting or changing output levels.

5. Dead Time Setting

In complementary PWM mode, PWM pulses are output with a non-overlapping relationship between the positive and negative phases. This non-overlap time is called the dead time.

The non-overlap time is set in the timer dead time data register (TDDR). The value set in TDDR is used as the TCNT_3 counter start value, and creates non-overlap between TCNT_3 and TCNT_4. Complementary PWM mode should be cleared before changing the contents of TDDR.

6. PWM Cycle Setting

In complementary PWM mode, the PWM pulse cycle is set in two registers—TGRA_3, in which the TCNT_3 upper limit value is set, and TCDR, in which the TCNT_4 upper limit value is set. The settings should be made so as to achieve the following relationship between these two registers:

$$\text{TGRA_3 set value} = \text{TCDR set value} + \text{TDDR set value}$$

The TGRA_3 and TCDR settings are made by setting the values in buffer registers TGRC_3 and TCBR. The values set in TGRC_3 and TCBR are transferred simultaneously to TGRA_3 and TCDR in accordance with the transfer timing selected with bits MD3 to MD0 in the timer mode register (TMDR).

The updated PWM cycle is reflected from the next cycle when the data update is performed at the crest, and from the current cycle when performed in the trough. Figure 11.36 illustrates the operation when the PWM cycle is updated at the crest.

See the following section, Register Data Updating, for the method of updating the data in each buffer register.

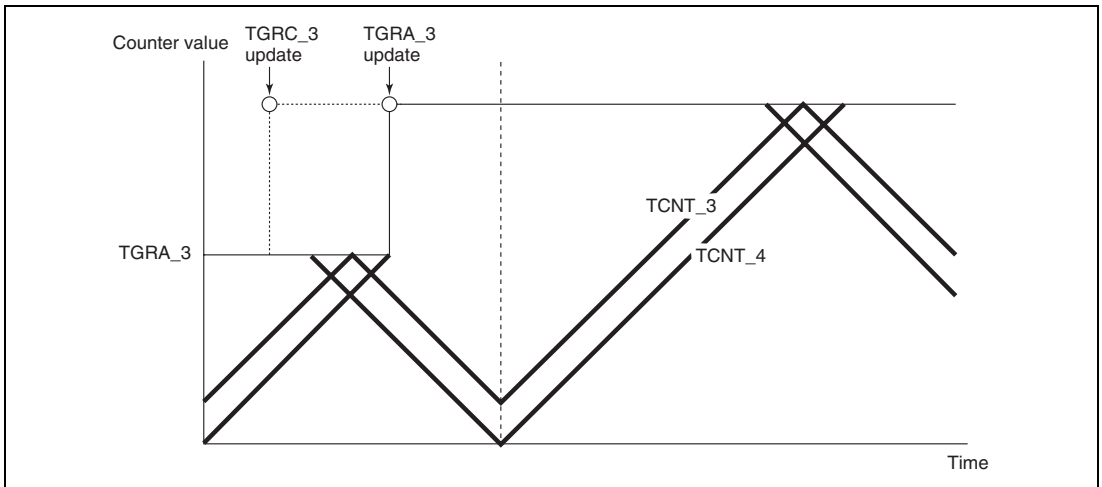

Figure 11.36 Example of PWM Cycle Updating

7. Register Data Updating

In complementary PWM mode, the buffer register is used to update the data in a compare register. The update data can be written to the buffer register at any time. There are five PWM duty and carrier cycle registers that have buffer registers and can be updated during operation. There is a temporary register between each of these registers and its buffer register. When subcounter TCNTS is not counting, if buffer register data is updated, the temporary register value is also rewritten. Transfer is not performed from buffer registers to temporary registers when TCNTS is counting; in this case, the value written to a buffer register is transferred after TCNTS halts.

The temporary register value is transferred to the compare register at the data update timing set with bits MD3 to MD0 in the timer mode register (TMDR). Figure 11.37 shows an example of data updating in complementary PWM mode. This example shows the mode in which data updating is performed at both the counter crest and trough.

When rewriting buffer register data, a write to TGRD_4 must be performed at the end of the update. Data transfer from the buffer registers to the temporary registers is performed simultaneously for all five registers after the write to TGRD_4.

A write to TGRD_4 must be performed after writing data to the registers to be updated, even when not updating all five registers, or when updating the TGRD_4 data. In this case, the data written to TGRD_4 should be the same as the data prior to the write operation.

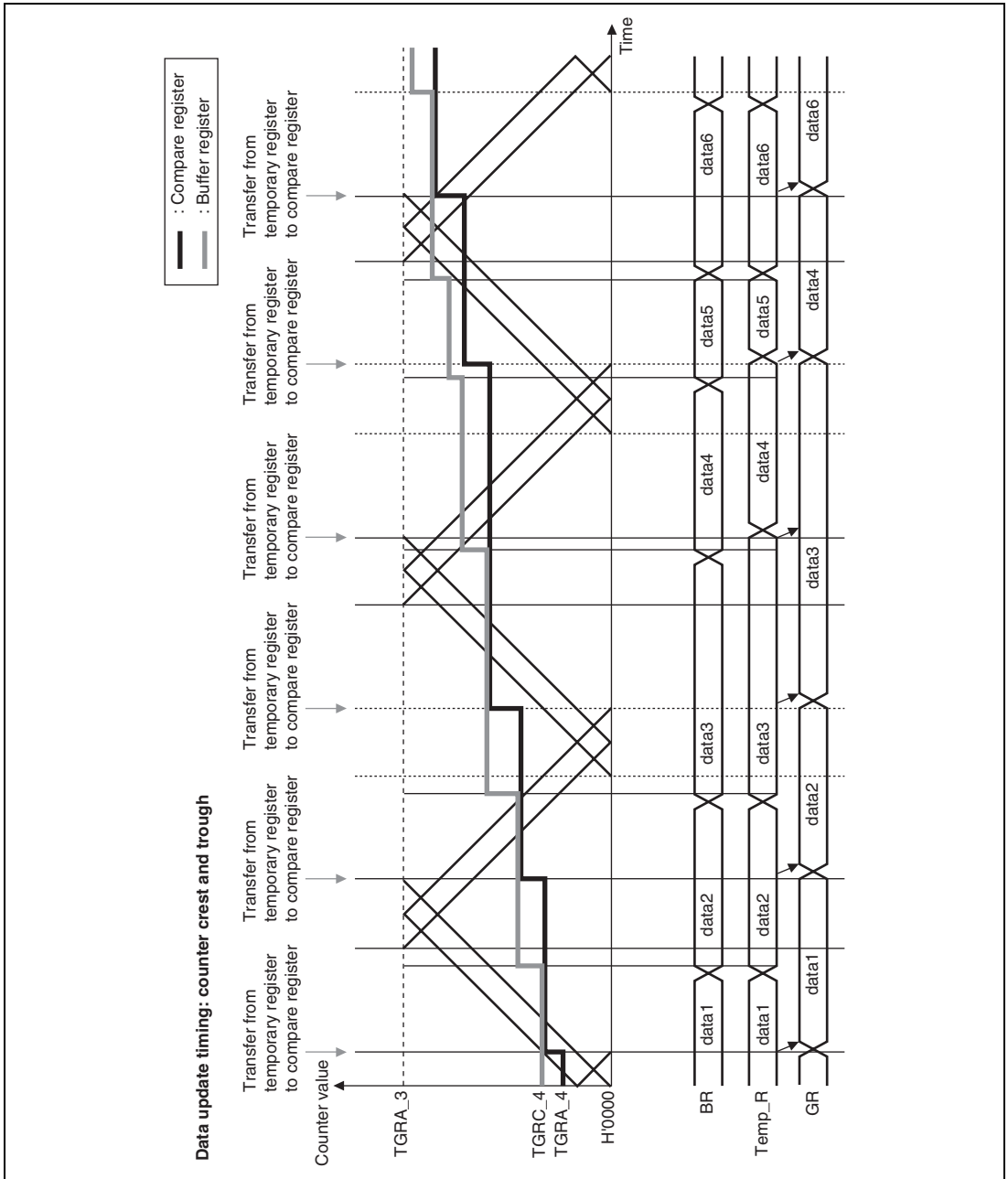

Figure 11.37 Example of Data Update in Complementary PWM Mode

8. Initial Output in Complementary PWM Mode:

In complementary PWM mode, the initial output is determined by the setting of bits OLSN and OLSP in the timer output control register (TOCR).

This initial output is the PWM pulse non-active level, and is output from when complementary PWM mode is set with the timer mode register (TMDR) until TCNT_4 exceeds the value set in the dead time register (TDDR). Figure 11.38 shows an example of the initial output in complementary PWM mode.

An example of the waveform when the initial PWM duty value is smaller than the TDDR value is shown in figure 11.39.

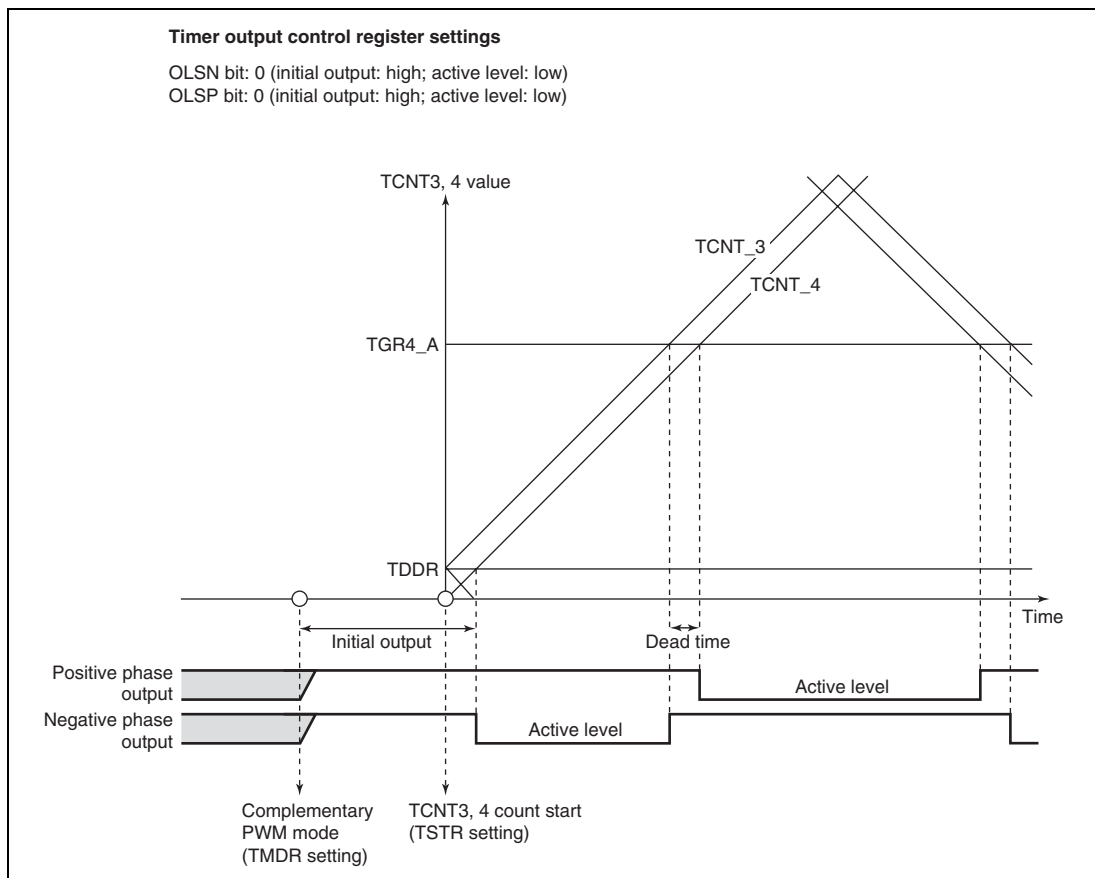

Figure 11.38 Example of Initial Output in Complementary PWM Mode (1)

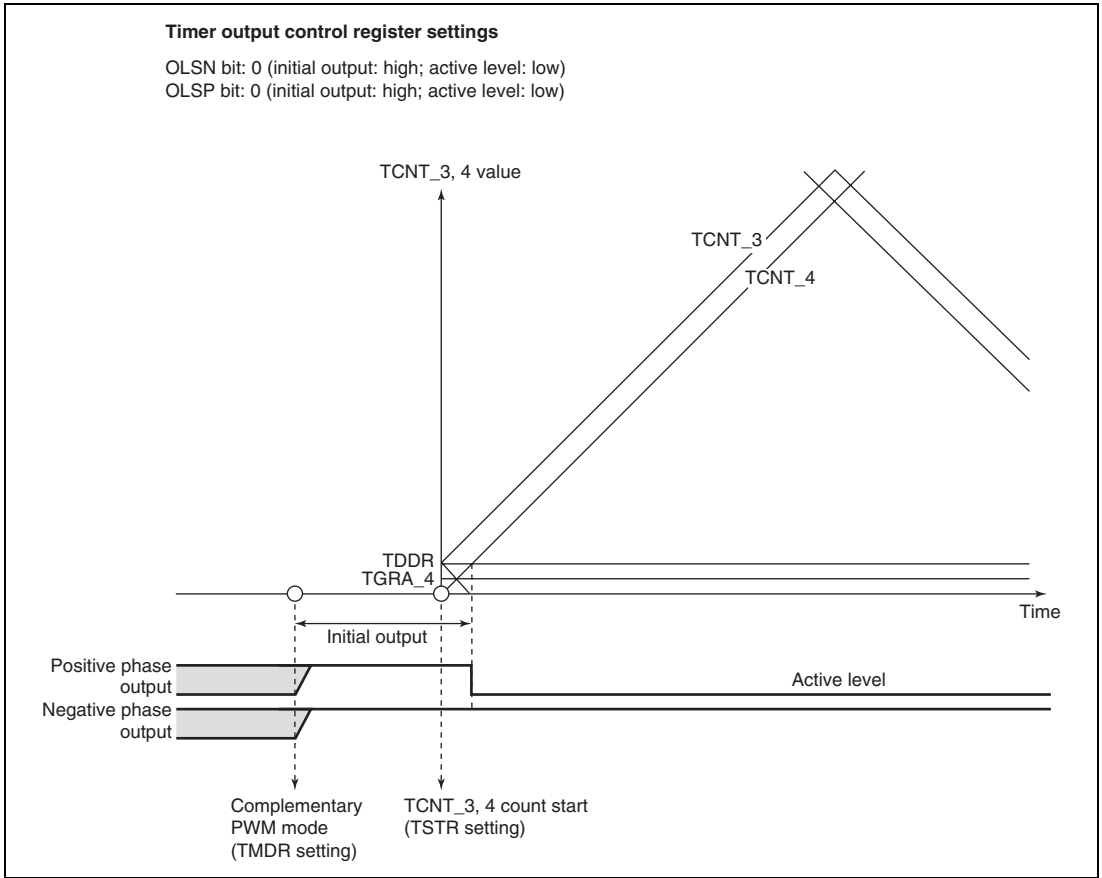

Figure 11.39 Example of Initial Output in Complementary PWM Mode (2)

9. Complementary PWM Mode PWM Output Generation Method:

In complementary PWM mode, 3-phase output is performed of PWM waveforms with a non-overlap time between the positive and negative phases. This non-overlap time is called the dead time.

A PWM waveform is generated by output of the output level selected in the timer output control register in the event of a compare-match between a counter and data register. While TCNTS is counting, data register and temporary register values are simultaneously compared to create consecutive PWM pulses from 0 to 100%. The relative timing of on and off compare-match occurrence may vary, but the compare-match that turns off each phase takes precedence to secure the dead time and ensure that the positive phase and negative phase on times do not overlap. Figures 11.40 to 11.42 show examples of waveform generation in complementary PWM mode.

The positive phase/negative phase off timing is generated by a compare-match with the solid-line counter, and the on timing by a compare-match with the dotted-line counter operating with a delay of the dead time behind the solid-line counter. In the T1 period, compare-match **a** that turns off the negative phase has the highest priority, and compare-matches occurring prior to **a** are ignored. In the T2 period, compare-match **c** that turns off the positive phase has the highest priority, and compare-matches occurring prior to **c** are ignored.

In normal cases, compare-matches occur in the order **a** → **b** → **c** → **d** (or **c** → **d** → **a'** → **b'**), as shown in figure 11.40.

If compare-matches deviate from the **a** → **b** → **c** → **d** order, since the time for which the negative phase is off is less than twice the dead time, the figure shows the positive phase is not being turned on. If compare-matches deviate from the **c** → **d** → **a'** → **b'** order, since the time for which the positive phase is off is less than twice the dead time, the figure shows the negative phase is not being turned on.

If compare-match **c** occurs first following compare-match **a**, as shown in figure 11.41, compare-match **b** is ignored, and the negative phase is turned off by compare-match **d**. This is because turning off of the positive phase has priority due to the occurrence of compare-match **c** (positive phase off timing) before compare-match **b** (positive phase on timing) (consequently, the waveform does not change since the positive phase goes from off to off).

Similarly, in the example in figure 11.42, compare-match **a'** with the new data in the temporary register occurs before compare-match **c**, but other compare-matches occurring up to **c**, which turns off the positive phase, are ignored. As a result, the positive phase is not turned on.

Thus, in complementary PWM mode, compare-matches at turn-off timings take precedence, and turn-on timing compare-matches that occur before a turn-off timing compare-match are ignored.

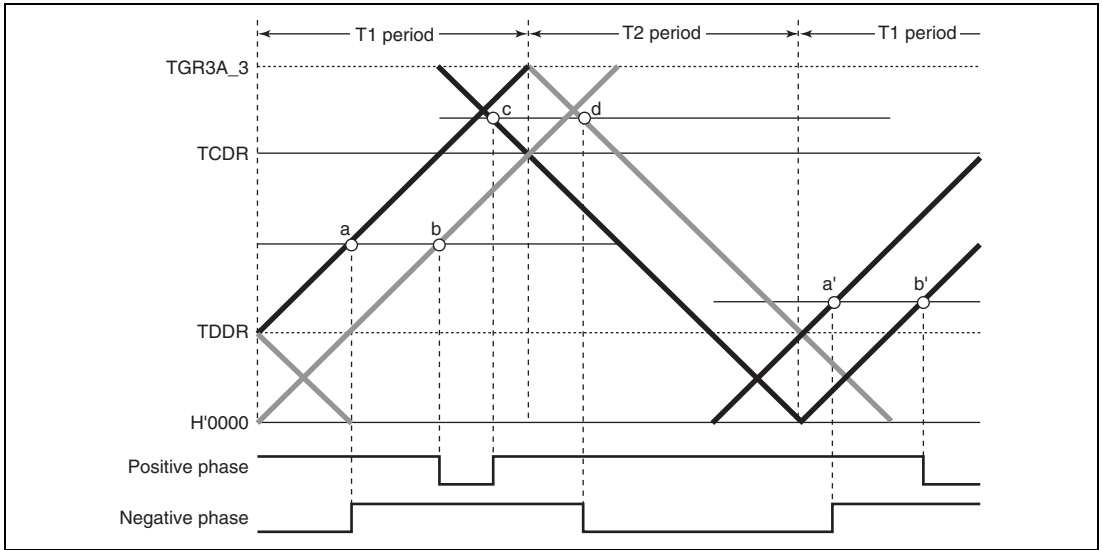

Figure 11.40 Example of Complementary PWM Mode Waveform Output (1)

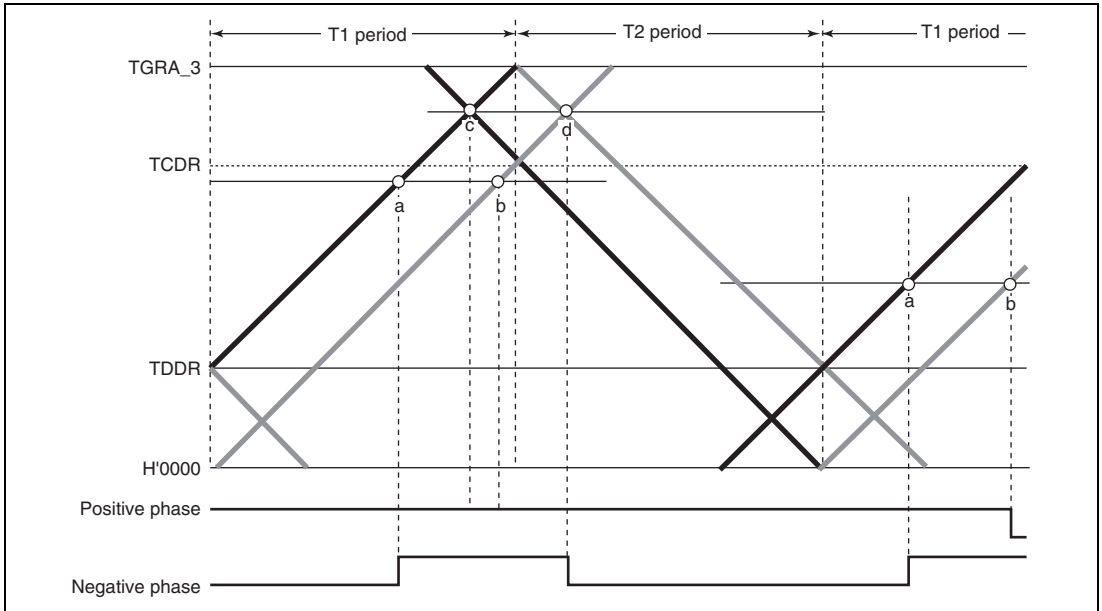

Figure 11.41 Example of Complementary PWM Mode Waveform Output (2)

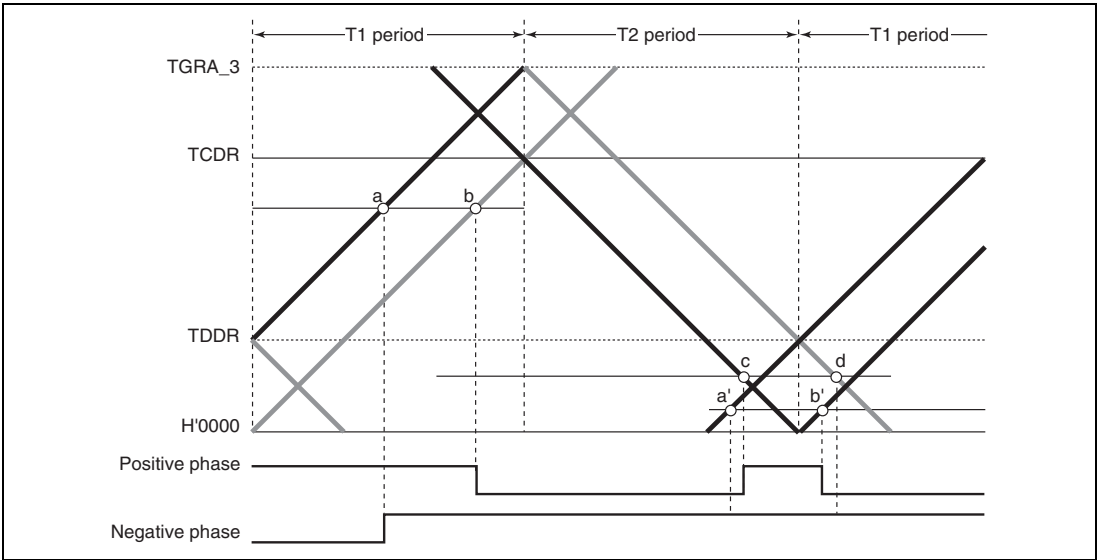

Figure 11.42 Example of Complementary PWM Mode Waveform Output (3)

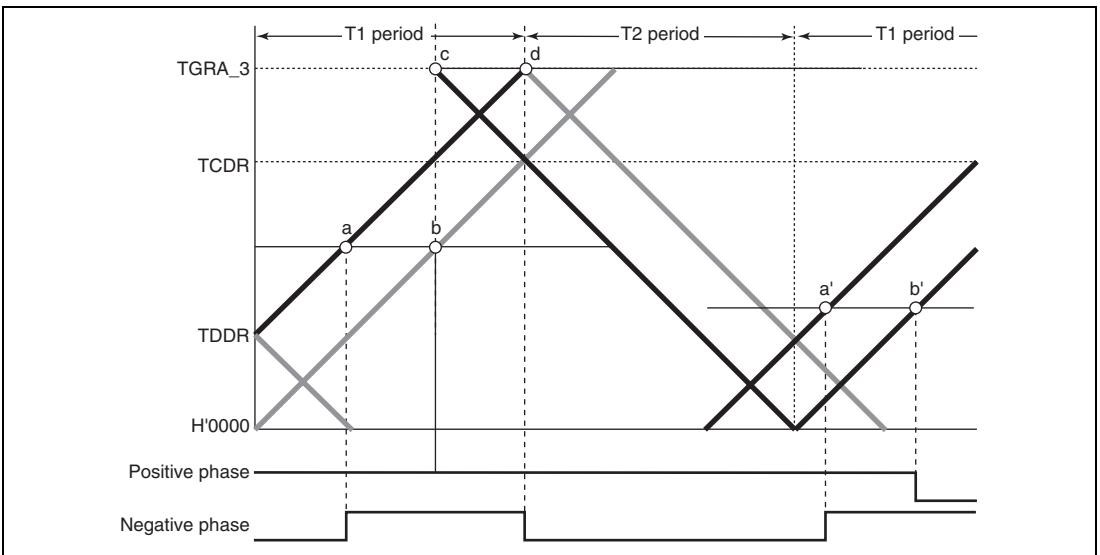

Figure 11.43 Example of Complementary PWM Mode 0% and 100% Waveform Output (1)

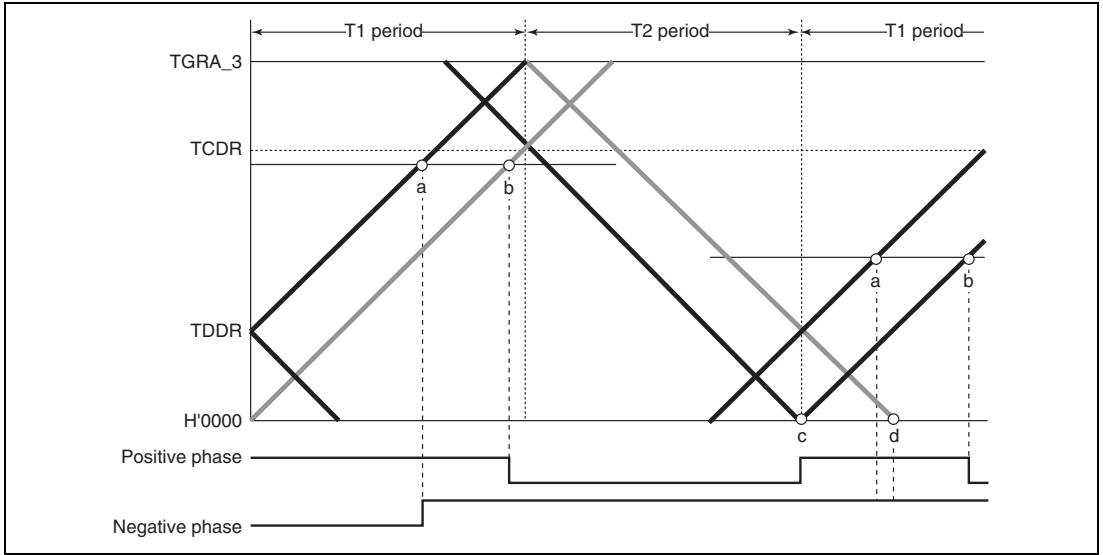

Figure 11.44 Example of Complementary PWM Mode 0% and 100% Waveform Output (2)

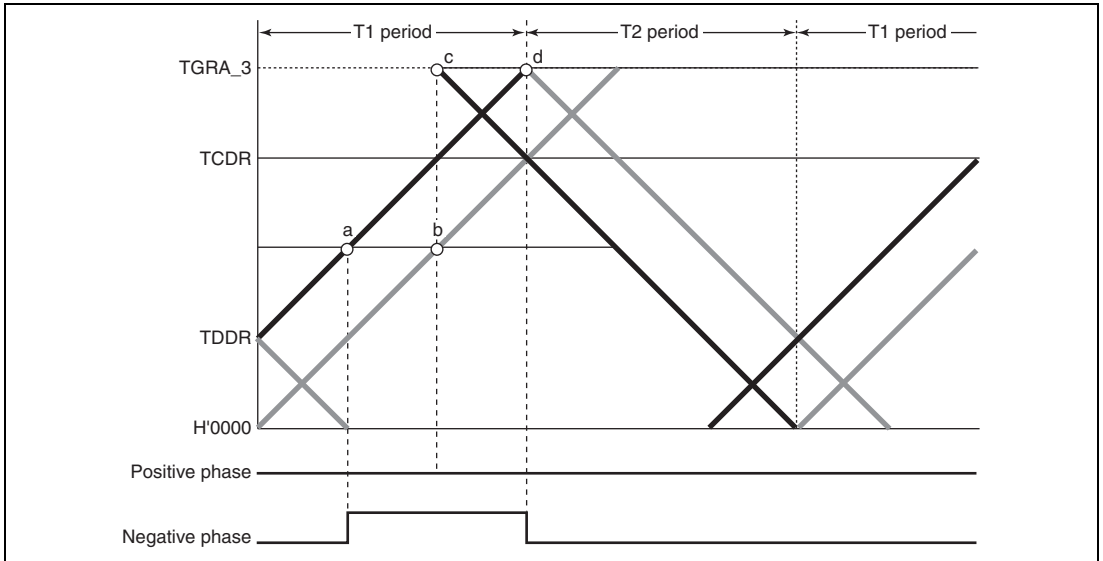

Figure 11.45 Example of Complementary PWM Mode 0% and 100% Waveform Output (3)

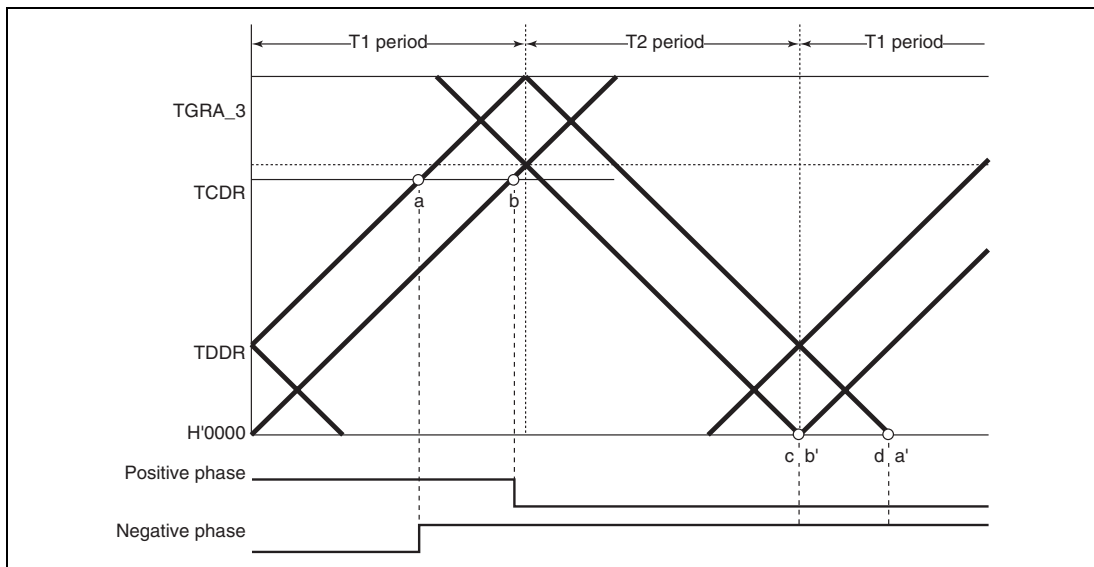

Figure 11.46 Example of Complementary PWM Mode 0% and 100% Waveform Output (4)

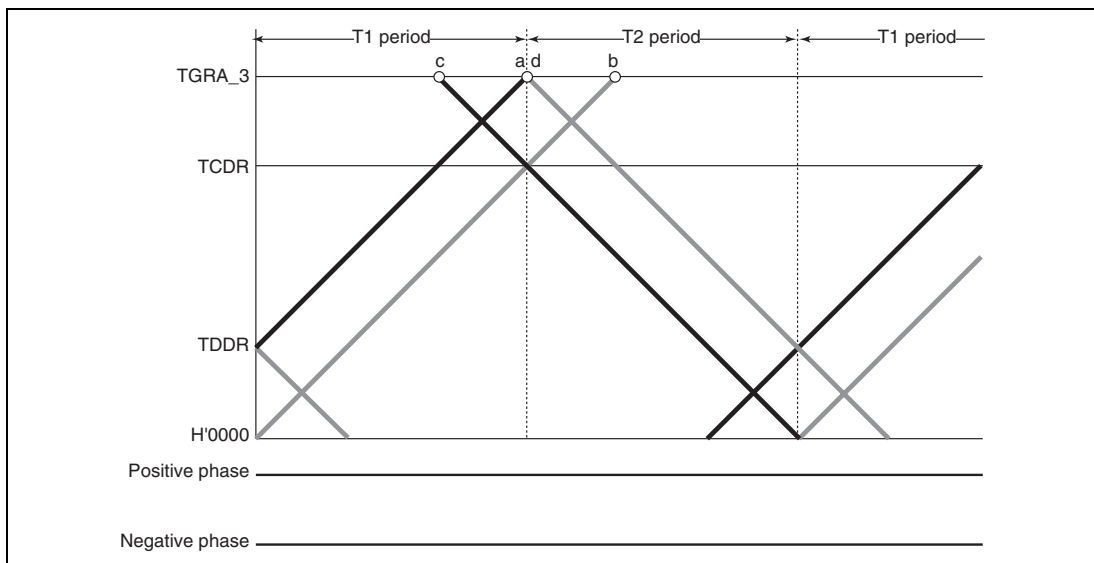

Figure 11.47 Example of Complementary PWM Mode 0% and 100% Waveform Output (5)

10. Complementary PWM Mode 0% and 100% Duty Output:

In complementary PWM mode, 0% and 100% duty cycles can be output as required. Figures 11.43 to 11.47 show output examples.

100% duty output is performed when the data register value is set to H'0000. The waveform in this case has a positive phase with a 100% on-state. 0% duty output is performed when the data register value is set to the same value as TGRA_3. The waveform in this case has a positive phase with a 100% off-state.

On and off compare-matches occur simultaneously, but if a turn-on compare-match and turn-off compare-match for the same phase occur simultaneously, both compare-matches are ignored and the waveform does not change.

11. Toggle Output Synchronized with PWM Cycle

In complementary PWM mode, toggle output can be performed in synchronization with the PWM carrier cycle by setting the PSYE bit to 1 in the timer output control register (TOCR). An example of a toggle output waveform is shown in figure 11.48.

This output is toggled by a compare-match between TCNT_3 and TGRA_3 and a compare-match between TCNT4 and H'0000.

The output pin for this toggle output is the TIOC3A pin. The initial output is 1.

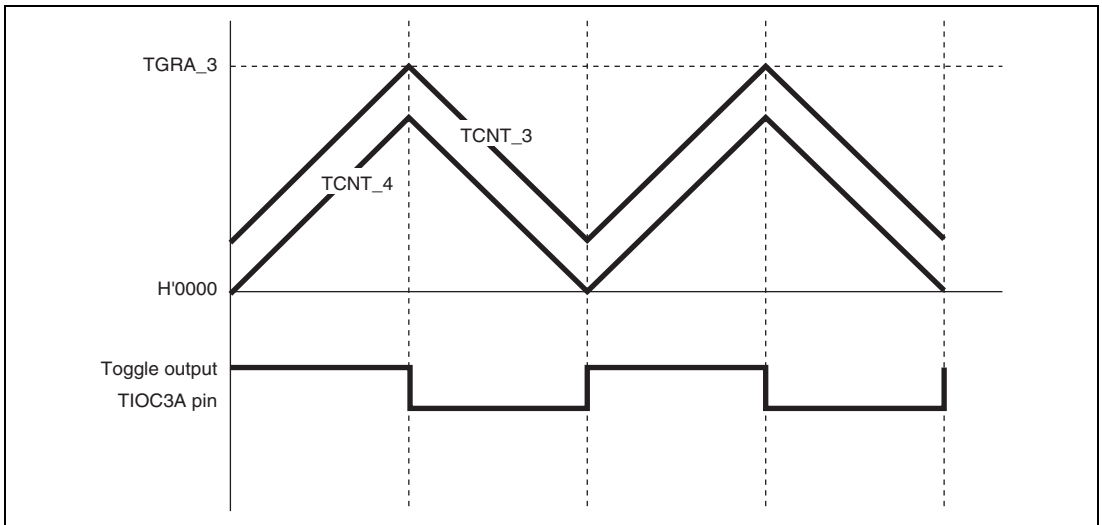

Figure 11.48 Example of Toggle Output Waveform Synchronized with PWM Output

12. Counter Clearing by another Channel

In complementary PWM mode, by setting a mode for synchronization with another channel by means of the timer synchronous register (TSYR), and selecting synchronous clearing with bits CCLR2 to CCLR0 in the timer control register (TCR), it is possible to have TCNT_3, TCNT_4, and TCNTS cleared by another channel.

Figure 11.49 illustrates the operation.

Use of this function enables counter clearing and restarting to be performed by means of an external signal.

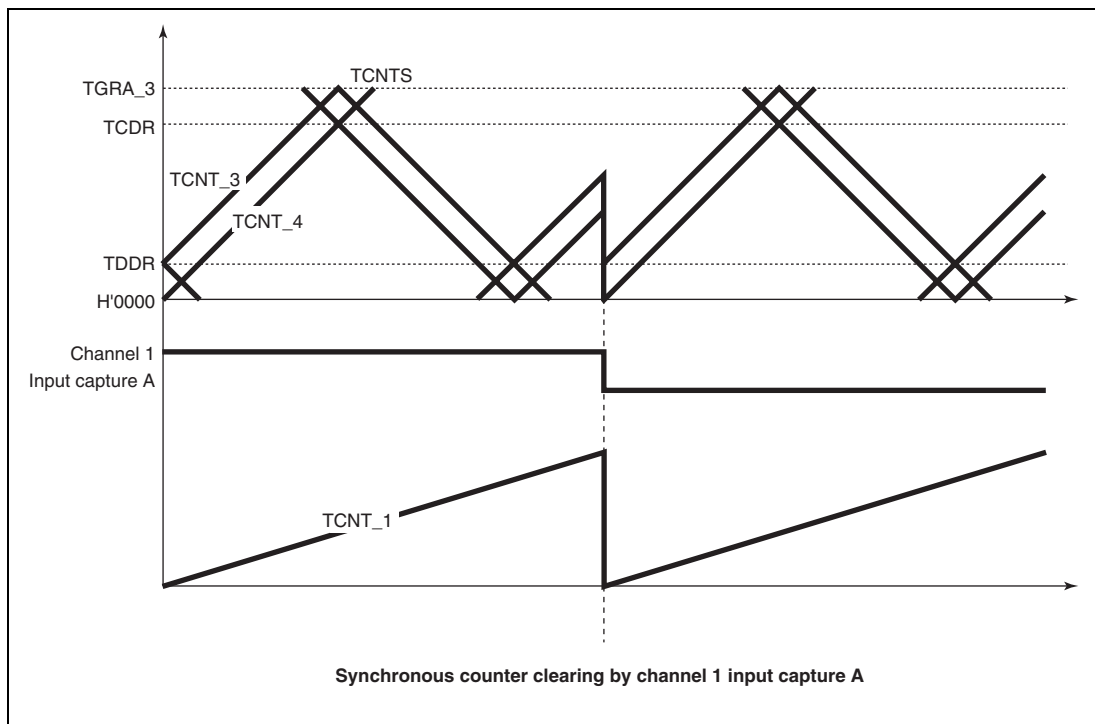

Figure 11.49 Counter Clearing Synchronized with Another Channel

13. Example of AC Synchronous Motor (Brushless DC Motor) Drive Waveform Output

In complementary PWM mode, a brushless DC motor can easily be controlled using the timer gate control register (TGCR). Figures 11.50 to 11.53 show examples of brushless DC motor drive waveforms created using TGCR.

When output phase switching for a 3-phase brushless DC motor is performed by means of external signals detected with a Hall element, etc., clear the FB bit in TGCR to 0. In this case, the external signals indicating the polarity position are input to channel 0 timer input pins TIOC0A, TIOC0B, and TIOC0C (set with PFC). When an edge is detected at pin TIOC0A, TIOC0B, or TIOC0C, the output on/off state is switched automatically.

When the FB bit is 1, the output on/off state is switched when the UF, VF, or WF bit in TGCR is cleared to 0 or set to 1.

The drive waveforms are output from the complementary PWM mode 6-phase output pins. With this 6-phase output, in the case of on output, it is possible to use complementary PWM mode output and perform chopping output by setting the N bit or P bit to 1. When the N bit or P bit is 0, level output is selected.

The 6-phase output active level (on output level) can be set with the OLSN and OLSP bits in the timer output control register (TOCR) regardless of the setting of the N and P bits.

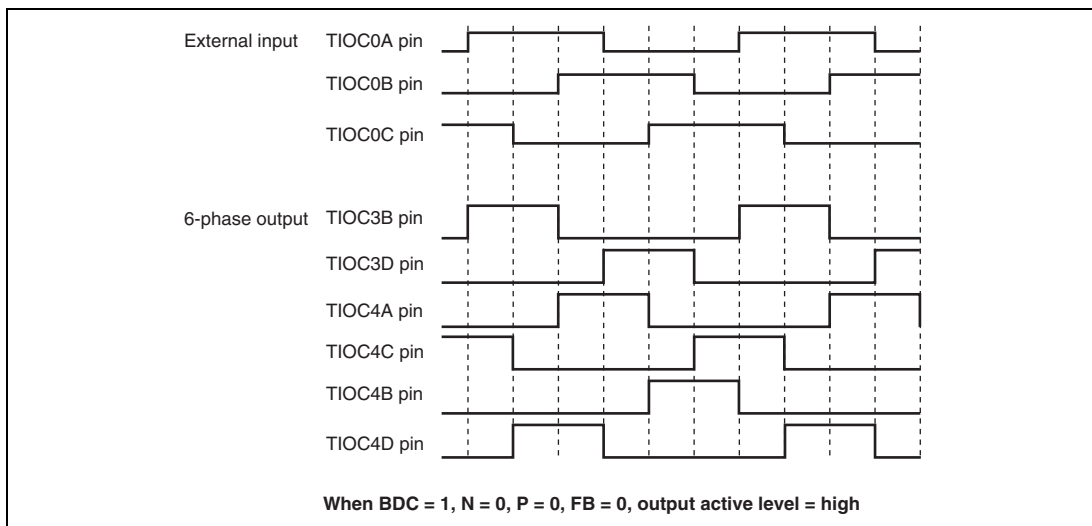

Figure 11.50 Example of Output Phase Switching by External Input (1)

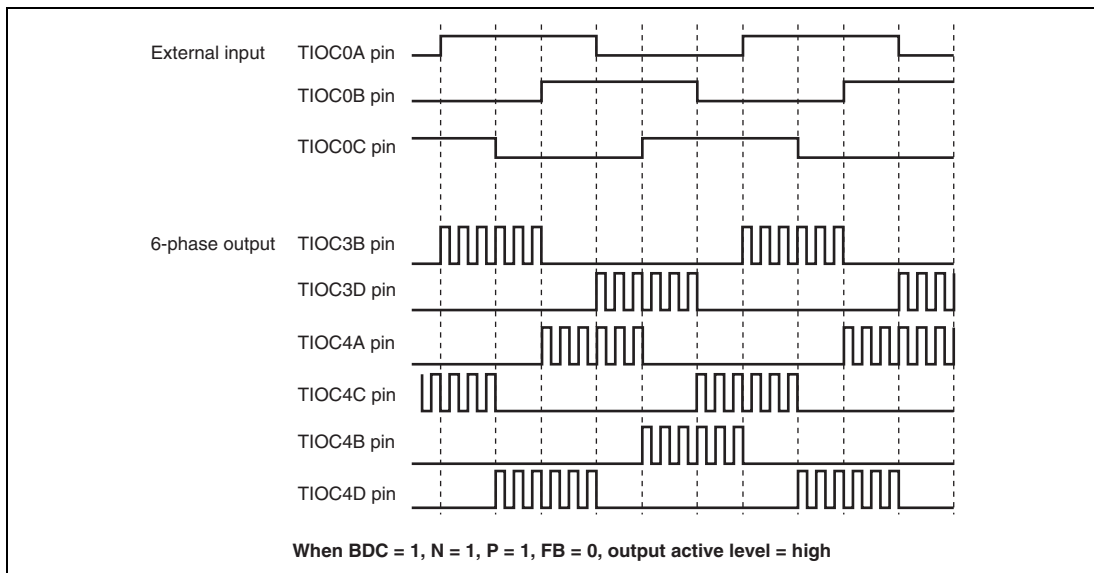

Figure 11.51 Example of Output Phase Switching by External Input (2)

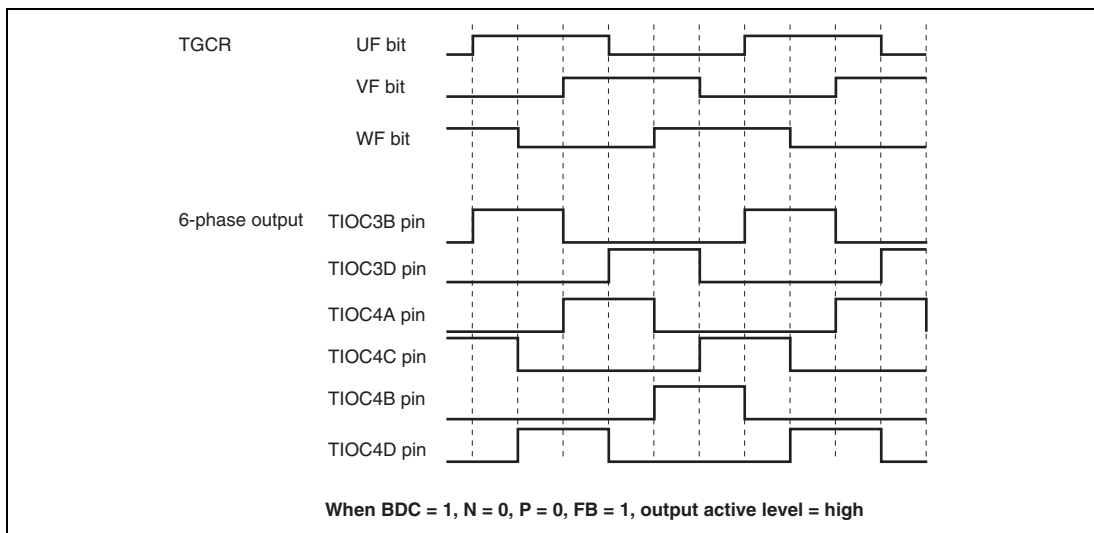

Figure 11.52 Example of Output Phase Switching by Means of UF, VF, WF Bit Settings (1)

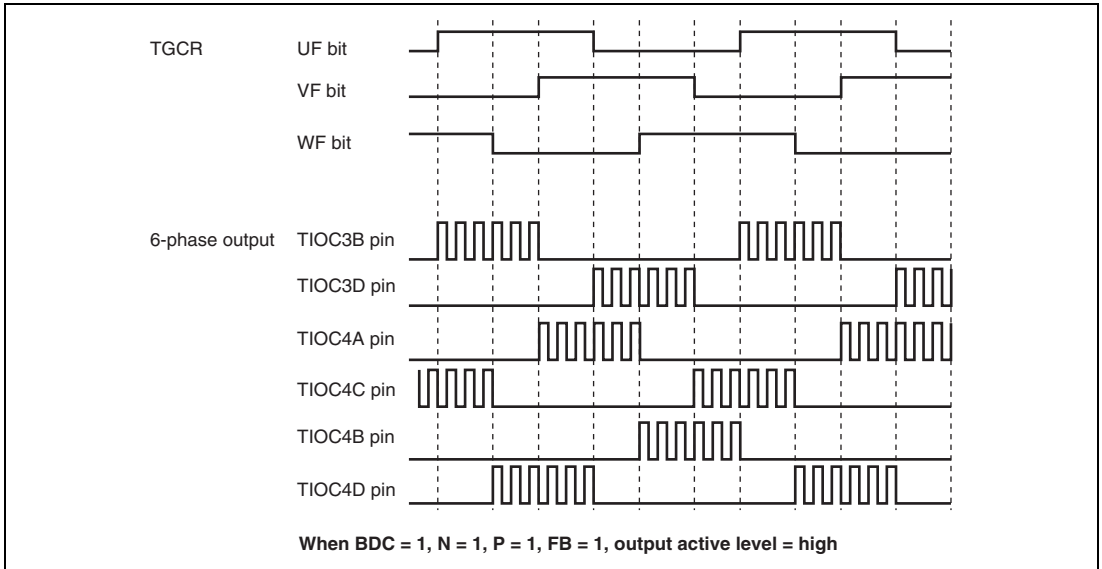

Figure 11.53 Example of Output Phase Switching by Means of UF, VF, WF Bit Settings (2)

14. A/D Conversion Start Request Setting:

In complementary PWM mode, an A/D conversion start request can be issued using a TGRA_3 compare-match or a compare-match on a channel other than channels 3 and 4.

When start requests using a TGRA_3 compare-match are set, A/D conversion can be started at the center of the PWM pulse.

A/D conversion start requests can be set by setting the TTGE bit to 1 in the timer interrupt enable register (TIER).

Complementary PWM Mode Output Protection Function:

Complementary PWM mode output has the following protection functions.

1. Register and counter miswrite prevention function

With the exception of the buffer registers, which can be rewritten at any time, access by the CPU can be enabled or disabled for the mode registers, control registers, compare registers, and counters used in complementary PWM mode by means of the MTURWE bit in the bus controller's bus control register 1 (BCR1). The applicable registers are some (21 in total) of the registers in channels 3 and 4 shown in the following:

— TCR_3 and TCR_4, TMDR_3 and TMDR_4, TIORH_3 and TIORH_4, TIORL_3 and TIORL_4, TIER_3 and TIER_4, TCNT_3 and TCNT_4, TGRA_3 and TGRA_4, TGRB_3 and TGRB_4, TOER, TOCR, TGCR, TCDR, and TDDR.

This function enables miswriting due to CPU runaway to be prevented by disabling CPU access to the mode registers, control registers, and counters. When the applicable registers are read in the access-disabled state, undefined values are returned. Writing to these registers is ignored.

2. Halting of PWM output by external signal

The 6-phase PWM output pins can be set automatically to the high-impedance state by inputting specified external signals. There are four external signal input pins.

See section 11.9, Port Output Enable (POE), for details.

3. Halting of PWM output when oscillator is stopped

If it is detected that the clock input to this LSI has stopped, the 6-phase PWM output pins automatically go to the high-impedance state. The pin states are not guaranteed when the clock is restarted.

See section 4.2, Function for Detecting Oscillator Halt.

11.5 Interrupt Sources

11.5.1 Interrupt Sources and Priorities

There are three kinds of MTU interrupt source; TGR input capture/compare match, TCNT overflow, and TCNT underflow. Each interrupt source has its own status flag and enable/disabled bit, allowing the generation of interrupt request signals to be enabled or disabled individually.

When an interrupt request is generated, the corresponding status flag in TSR is set to 1. If the corresponding enable/disable bit in TIER is set to 1 at this time, an interrupt is requested. The interrupt request is cleared by clearing the status flag to 0.

Relative channel priorities can be changed by the interrupt controller, however the priority order within a channel is fixed. For details, see section 6, Interrupt Controller (INTC).

Table 11.42 lists the MTU interrupt sources.

Table 11.42 MTU Interrupts

| Channel | Name | Interrupt Source | Interrupt Flag | DMAC Activation | DTC Activation | Priority |
|---------|--------|------------------------------------|----------------|-----------------|----------------|-----------|
| 0 | TGIA_0 | TGRA_0 input capture/compare match | TGFA_0 | Possible | Possible | High ↑ |
| | TGIB_0 | TGRB_0 input capture/compare match | TGFB_0 | Not possible | Possible | |
| | TGIC_0 | TGRC_0 input capture/compare match | TGFC_0 | Not possible | Possible | |
| | TGID_0 | TGRD_0 input capture/compare match | TGFD_0 | Not possible | Possible | |
| | TCIV_0 | TCNT_0 overflow | TCFV_0 | Not possible | Not possible | |
| 1 | TGIA_1 | TGRA_1 input capture/compare match | TGFA_1 | Possible | Possible | |
| | TGIB_1 | TGRB_1 input capture/compare match | TGFB_1 | Not possible | Possible | |
| | TCIV_1 | TCNT_1 overflow | TCFV_1 | Not possible | Not possible | |
| | TCIU_1 | TCNT_1 underflow | TCFU_1 | Not possible | Not possible | |
| 2 | TGIA_2 | TGRA_2 input capture/compare match | TGFA_2 | Possible | Possible | |
| | TGIB_2 | TGRB_2 input capture/compare match | TGFB_2 | Not possible | Possible | |
| | TCIV_2 | TCNT_2 overflow | TCFV_2 | Not possible | Not possible | |
| | TCIU_2 | TCNT_2 underflow | TCFU_2 | Not possible | Not possible | |
| 3 | TGIA_3 | TGRA_3 input capture/compare match | TGFA_3 | Possible | Possible | |
| | TGIB_3 | TGRB_3 input capture/compare match | TGFB_3 | Not possible | Possible | |
| | TGIC_3 | TGRC_3 input capture/compare match | TGFC_3 | Not possible | Possible | |
| | TGID_3 | TGRD_3 input capture/compare match | TGFD_3 | Not possible | Possible | |
| | TCIV_3 | TCNT_3 overflow | TCFV_3 | Not possible | Not possible | |
| 4 | TGIA_4 | TGRA_4 input capture/compare match | TGFA_4 | Possible | Possible | |
| | TGIB_4 | TGRB_4 input capture/compare match | TGFB_4 | Not possible | Possible | |
| | TGIC_4 | TGRC_4 input capture/compare match | TGFC_4 | Not possible | Possible | |
| | TGID_4 | TGRD_4 input capture/compare match | TGFD_4 | Not possible | Possible | |
| | TCIV_4 | TCNT_4 overflow/underflow | TCFV_4 | Not possible | Possible | Low ↓ |

Note: This table shows the initial state immediately after a reset. The relative channel priorities can be changed by the interrupt controller.

Input Capture/Compare Match Interrupt: An interrupt is requested if the TGIE bit in TIER is set to 1 when the TGF flag in TSR is set to 1 by the occurrence of a TGR input capture/compare match on a particular channel. The interrupt request is cleared by clearing the TGF flag to 0. The MTU has 16 input capture/compare match interrupts, four each for channels 0, 3, and 4, and two each for channels 1 and 2.

Overflow Interrupt: An interrupt is requested if the TCIEV bit in TIER is set to 1 when the TCFV flag in TSR is set to 1 by the occurrence of TCNT overflow on a channel. The interrupt request is cleared by clearing the TCFV flag to 0. The MTU has five overflow interrupts, one for each channel.

Underflow Interrupt: An interrupt is requested if the TCIEU bit in TIER is set to 1 when the TCFU flag in TSR is set to 1 by the occurrence of TCNT underflow on a channel. The interrupt request is cleared by clearing the TCFU flag to 0. The MTU has two underflow interrupts, one each for channels 1 and 2.

11.5.2 DTC/DMAC Activation

DTC Activation: The DTC can be activated by the TGR input capture/compare match interrupt in each channel. For details, see section 8, Data Transfer Controller (DTC).

A total of 17 MTU input capture/compare match interrupts can be used as DTC activation sources, four each for channels 0 and 3, and two each for channels 1 and 2, and five for channel 4.

DMAC Activation: The DMAC can be activated by the TGRA input capture/compare match interrupt in each channel. For details, see section 10, Direct Memory Access Controller (DMAC).

A total of five MTU input capture/compare match interrupts can be used as DMAC activation sources, one for each channel.

11.5.3 A/D Converter Activation

The A/D converter can be activated by the TGRA input capture/compare match in each channel.

If the TTGE bit in TIER is set to 1 when the TGFA flag in TSR is set to 1 by the occurrence of a TGRA input capture/compare match on a particular channel, a request to start A/D conversion is sent to the A/D converter. If the MTU conversion start trigger has been selected on the A/D converter at this time, A/D conversion starts.

In the MTU, a total of five TGRA input capture/compare match interrupts can be used as A/D converter conversion start sources, one for each channel.

11.6 Operation Timing

11.6.1 Input/Output Timing

TCNT Count Timing: Figure 11.54 shows TCNT count timing in internal clock operation, and figure 11.55 shows TCNT count timing in external clock operation (normal mode), and figure 11.56 shows TCNT count timing in external clock operation (phase counting mode).

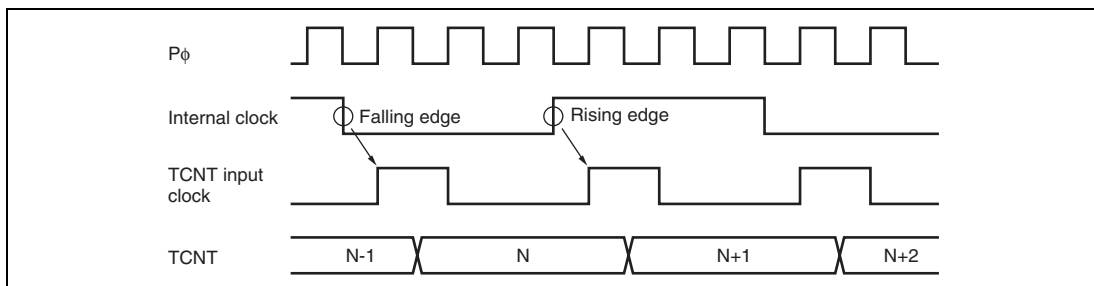

Figure 11.54 Count Timing in Internal Clock Operation

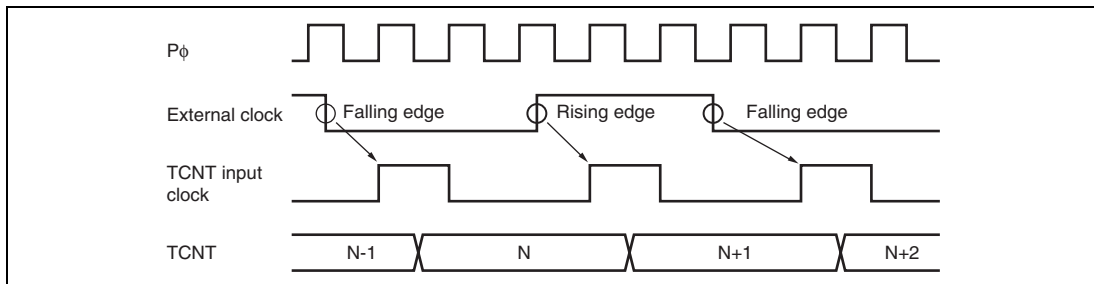

Figure 11.55 Count Timing in External Clock Operation

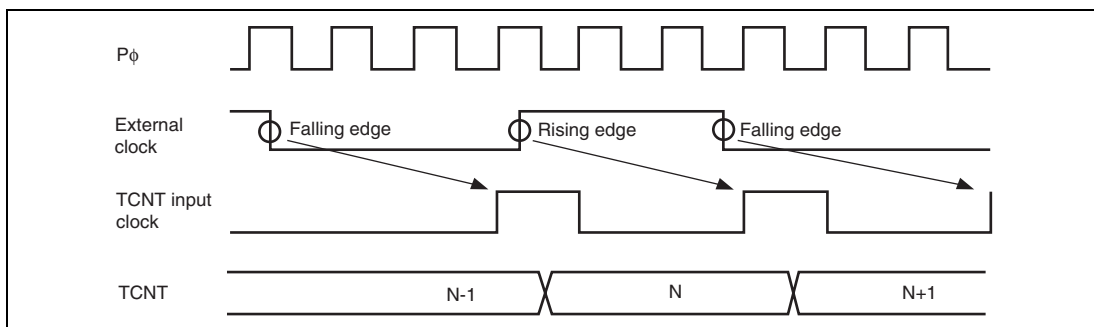

Figure 11.56 Count Timing in External Clock Operation (Phase Counting Mode)

Output Compare Output Timing: A compare match signal is generated in the final state in which TCNT and TGR match (the point at which the count value matched by TCNT is updated). When a compare match signal is generated, the output value set in TIOR is output at the output compare output pin (TIOC pin). After a match between TCNT and TGR, the compare match signal is not generated until the TCNT input clock is generated.

Figure 11.57 shows output compare output timing (normal mode and PWM mode) and figure 11.58 shows output compare output timing (complementary PWM mode and reset synchronous PWM mode).

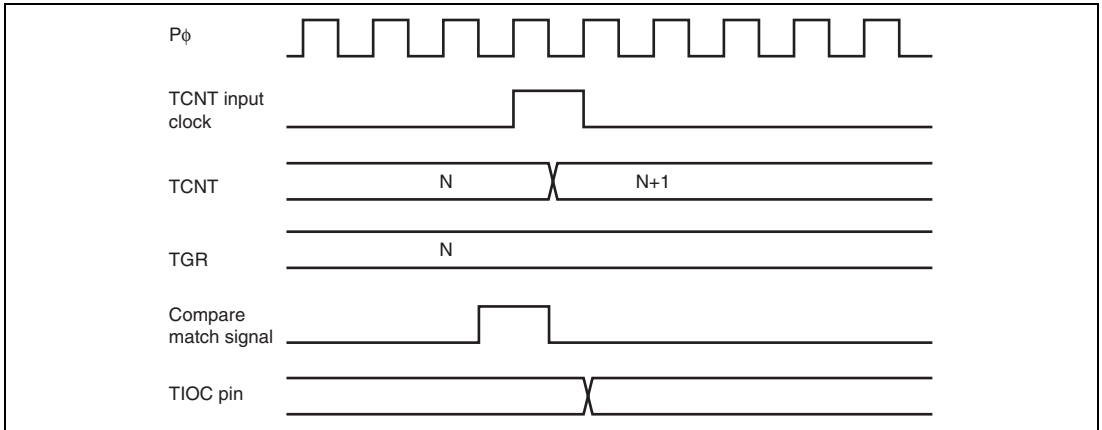

Figure 11.57 Output Compare Output Timing (Normal Mode/PWM Mode)

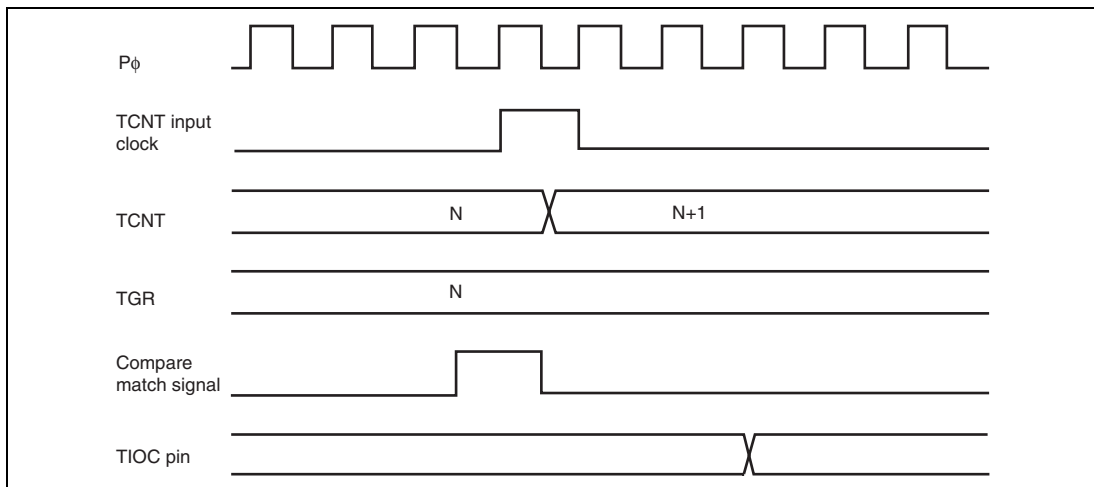

Figure 11.58 Output Compare Output Timing (Complementary PWM Mode/Reset Synchronous PWM Mode)

Input Capture Signal Timing: Figure 11.59 shows input capture signal timing.

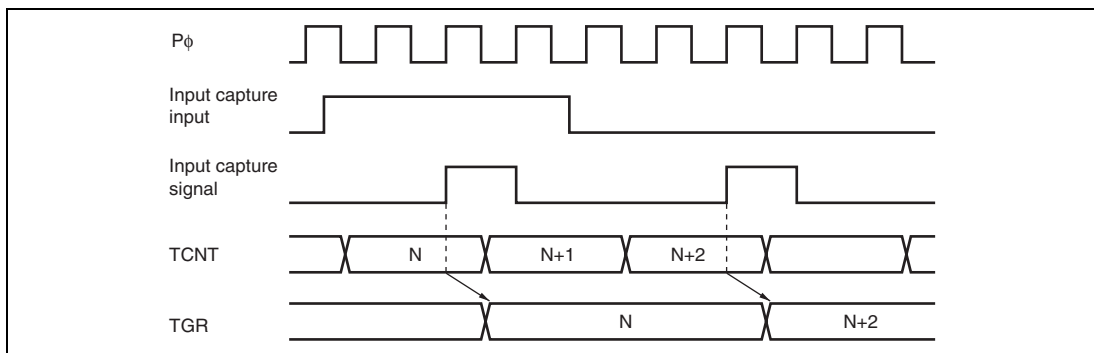

Figure 11.59 Input Capture Input Signal Timing

Timing for Counter Clearing by Compare Match/Input Capture: Figure 11.60 shows the timing when counter clearing on compare match is specified, and figure 11.61 shows the timing when counter clearing on input capture is specified.

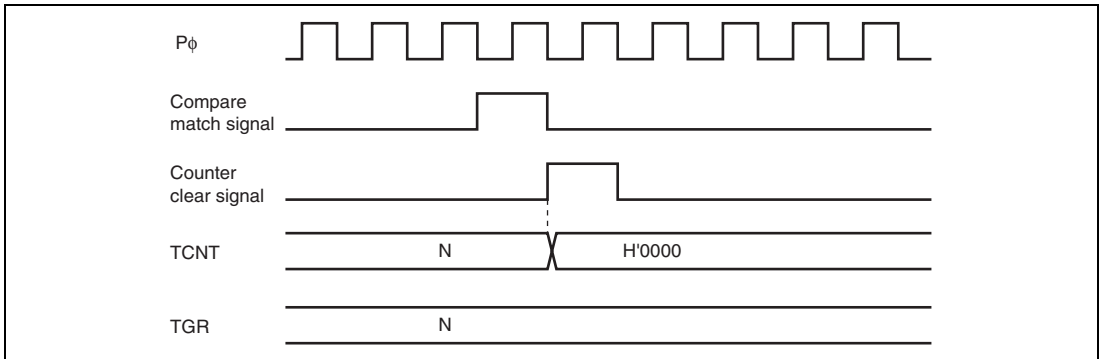

Figure 11.60 Counter Clear Timing (Compare Match)

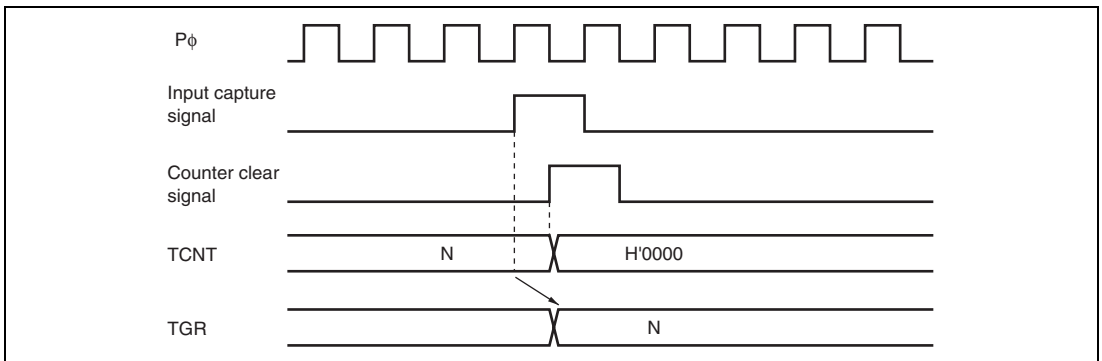

Figure 11.61 Counter Clear Timing (Input Capture)

Buffer Operation Timing: Figures 11.62 and 11.63 show the timing in buffer operation.

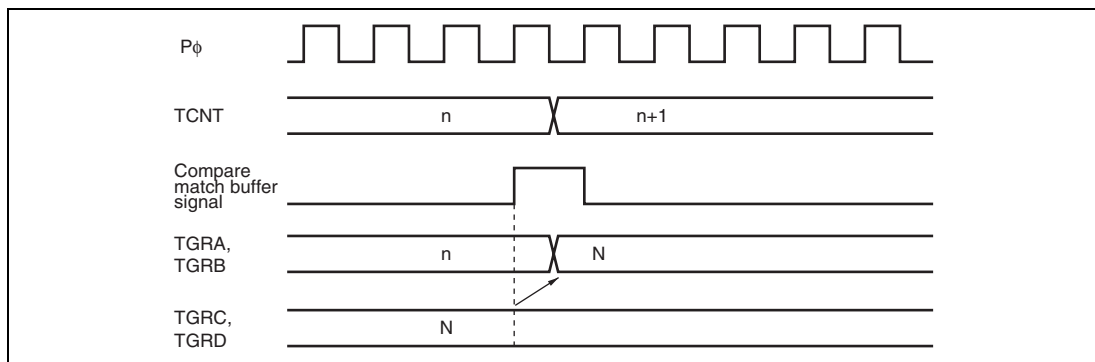

Figure 11.62 Buffer Operation Timing (Compare Match)

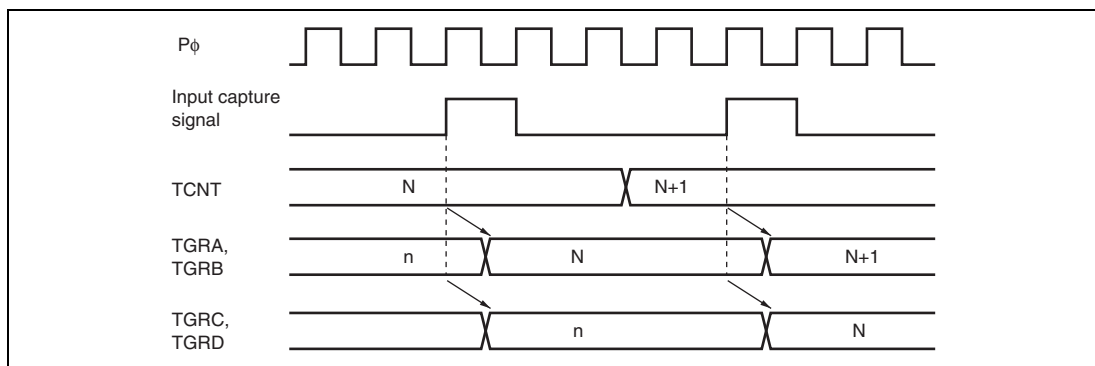

Figure 11.63 Buffer Operation Timing (Input Capture)

11.6.2 Interrupt Signal Timing

TGF Flag Setting Timing in Case of Compare Match: Figure 11.64 shows the timing for setting of the TGF flag in TSR on compare match, and TGI interrupt request signal timing.

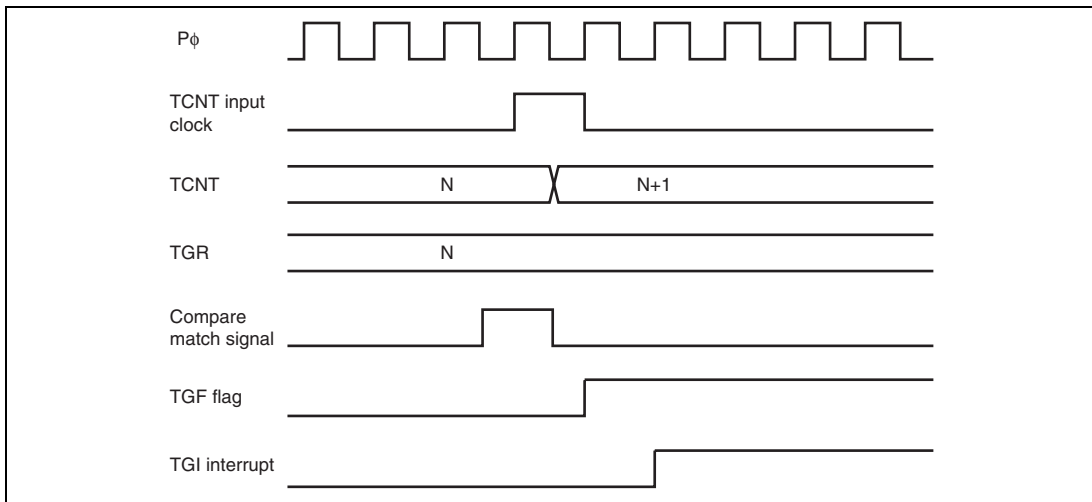

Figure 11.64 TGI Interrupt Timing (Compare Match)

TGF Flag Setting Timing in Case of Input Capture: Figure 11.65 shows the timing for setting of the TGF flag in TSR on input capture, and TGI interrupt request signal timing.

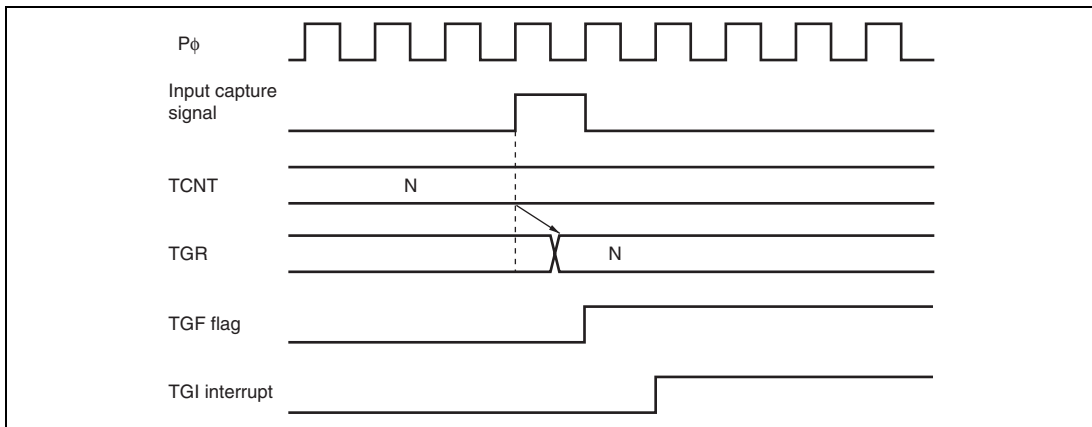

Figure 11.65 TGI Interrupt Timing (Input Capture)

TCFV Flag/TCFU Flag Setting Timing: Figure 11.66 shows the timing for setting of the TCFV flag in TSR on overflow, and TCIV interrupt request signal timing.

Figure 11.67 shows the timing for setting of the TCFU flag in TSR on underflow, and TCIU interrupt request signal timing.

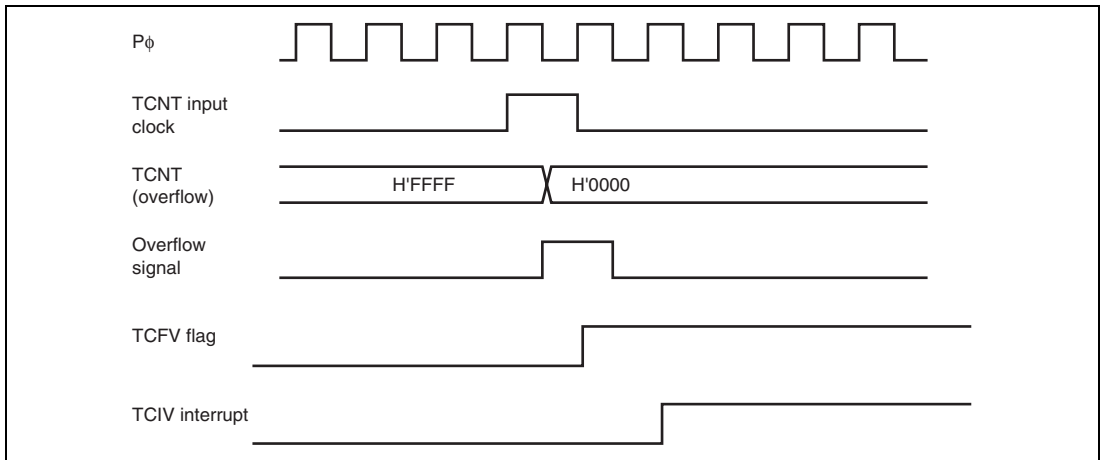

Figure 11.66 TCIV Interrupt Setting Timing

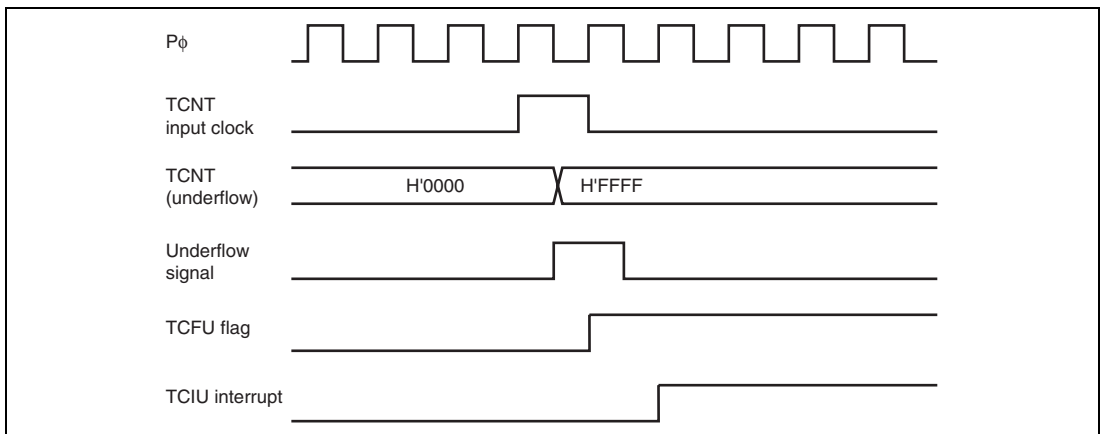

Figure 11.67 TCIU Interrupt Setting Timing

Status Flag Clearing Timing: After a status flag is read as 1 by the CPU, it is cleared by writing 0 to it. When the DTC/DMAC is activated, the flag is cleared automatically. Figure 11.68 shows the timing for status flag clearing by the CPU, and figure 11.69 shows the timing for status flag clearing by the DTC/DMAC.

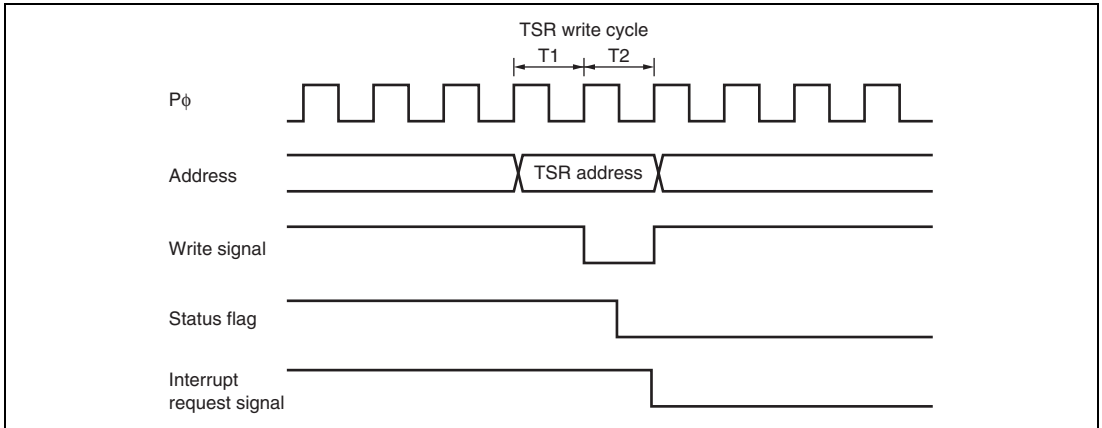

Figure 11.68 Timing for Status Flag Clearing by CPU

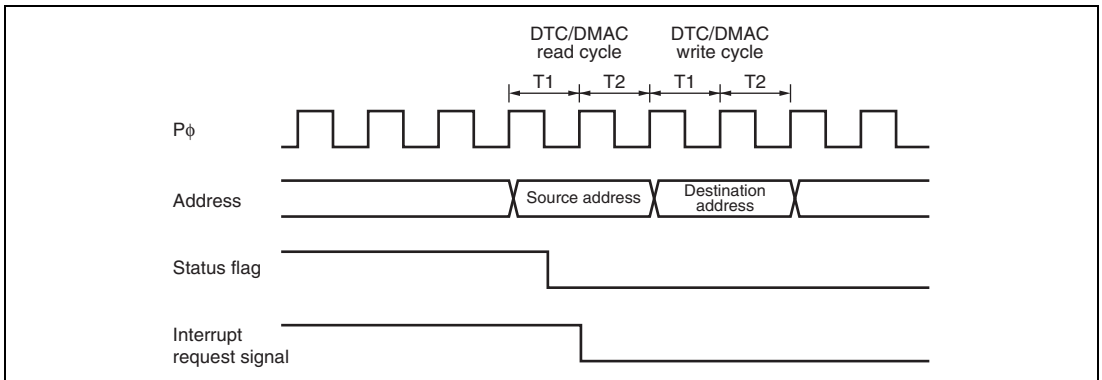

Figure 11.69 Timing for Status Flag Clearing by DTC/DMAC Activation

11.7 Usage Notes

11.7.1 Module Standby Mode Setting

MTU operation can be disabled or enabled using the module standby register. The initial setting is for MTU operation to be halted. Register access is enabled by clearing module standby mode. For details, refer to section 24, Power-Down Modes.

11.7.2 Input Clock Restrictions

The input clock pulse width must be at least 1.5 states in the case of single-edge detection, and at least 2.5 states in the case of both-edge detection. The MTU will not operate properly at narrower pulse widths.

In phase counting mode, the phase difference and overlap between the two input clocks must be at least 1.5 states, and the pulse width must be at least 2.5 states. Figure 11.70 shows the input clock conditions in phase counting mode.

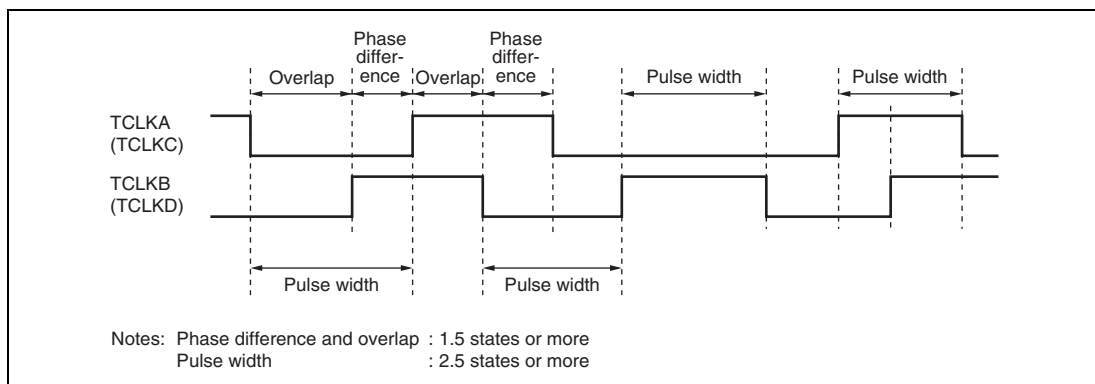

Figure 11.70 Phase Difference, Overlap, and Pulse Width in Phase Counting Mode

11.7.3 Caution on Period Setting

When counter clearing on compare match is set, TCNT is cleared in the final state in which it matches the TGR value (the point at which the count value matched by TCNT is updated). Consequently, the actual counter frequency is given by the following formula:

$$f = \frac{P\phi}{(N + 1)}$$

Where f: Counter frequency
 Pφ: Peripheral clock operating frequency
 N: TGR set value

11.7.4 Contention between TCNT Write and Clear Operations

If the counter clear signal is generated in the T2 state of a TCNT write cycle, TCNT clearing takes precedence and the TCNT write is not performed.

Figure 11.71 shows the timing in this case.

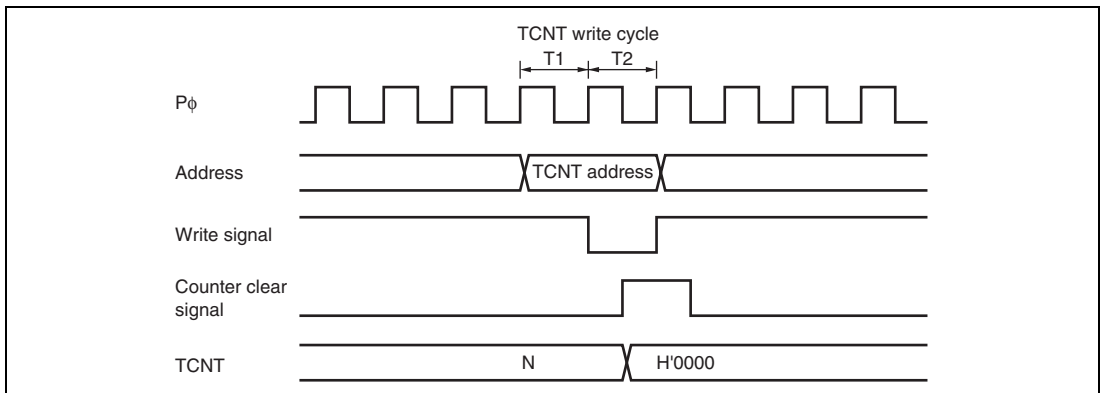

Figure 11.71 Contention between TCNT Write and Clear Operations

11.7.5 Contention between TCNT Write and Increment Operations

If incrementing occurs in the T2 state of a TCNT write cycle, the TCNT write takes precedence and TCNT is not incremented.

Figure 11.72 shows the timing in this case.

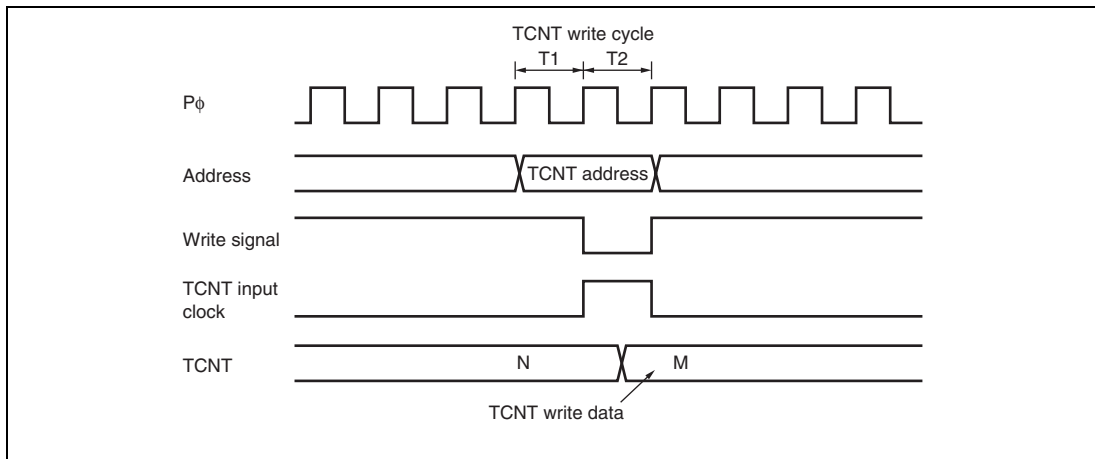

Figure 11.72 Contention between TCNT Write and Increment Operations

11.7.6 Contention between TGR Write and Compare Match

If a compare match occurs in the T2 state of a TGR write cycle, the TGR write is executed and the compare match signal is also generated.

Figure 11.73 shows the timing in this case.

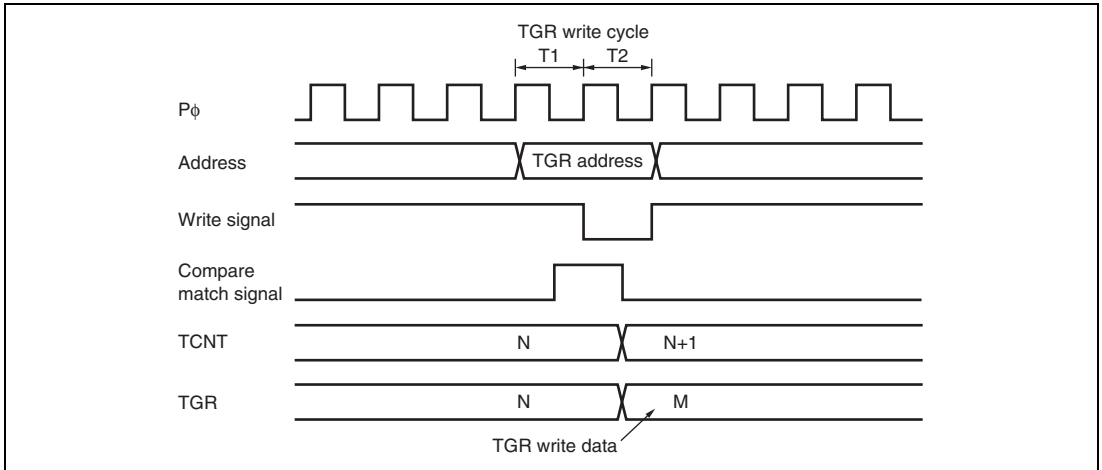

Figure 11.73 Contention between TGR Write and Compare Match

11.7.7 Contention between Buffer Register Write and Compare Match

If a compare match occurs in the T2 state of a TGR write cycle, the data that is transferred to TGR by the buffer operation differs depending on channel 0 and channels 3 and 4: data on channel 0 is that after write, and on channels 3 and 4, before write.

Figures 11.74 and 11.75 show the timing in this case.

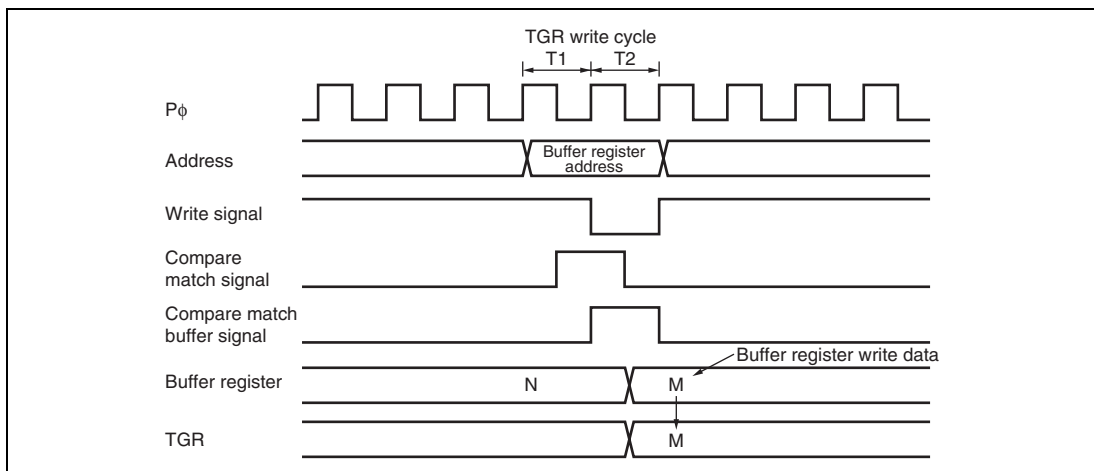

Figure 11.74 Contention between Buffer Register Write and Compare Match (Channel 0)

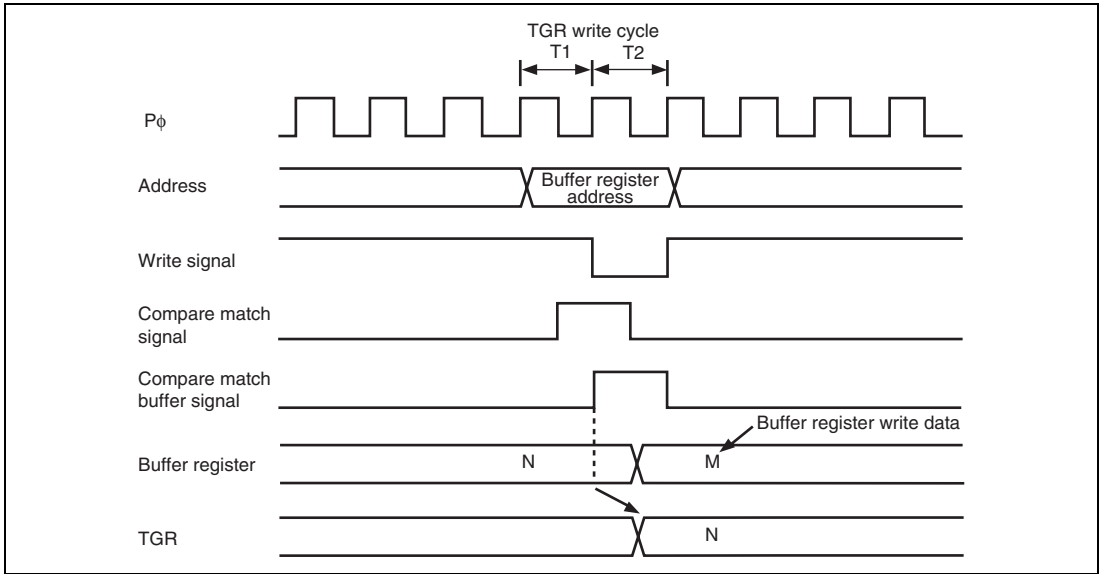

Figure 11.75 Contention between Buffer Register Write and Compare Match (Channels 3 and 4)

11.7.8 Contention between TGR Read and Input Capture

If an input capture signal is generated in the T1 state of a TGR read cycle, the data that is read will be that in the buffer after input capture transfer.

Figure 11.76 shows the timing in this case.

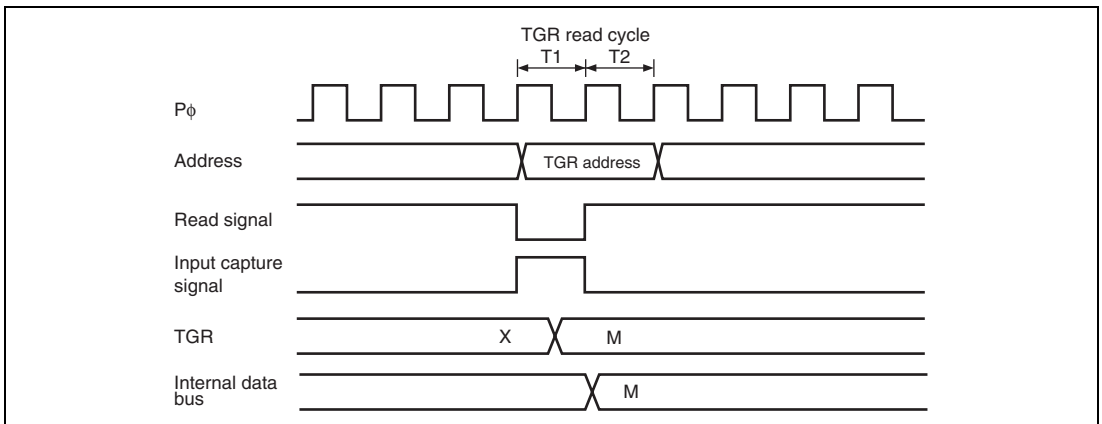

Figure 11.76 Contention between TGR Read and Input Capture

11.7.9 Contention between TGR Write and Input Capture

If an input capture signal is generated in the T2 state of a TGR write cycle, the input capture operation takes precedence and the write to TGR is not performed.

Figure 11.77 shows the timing in this case.

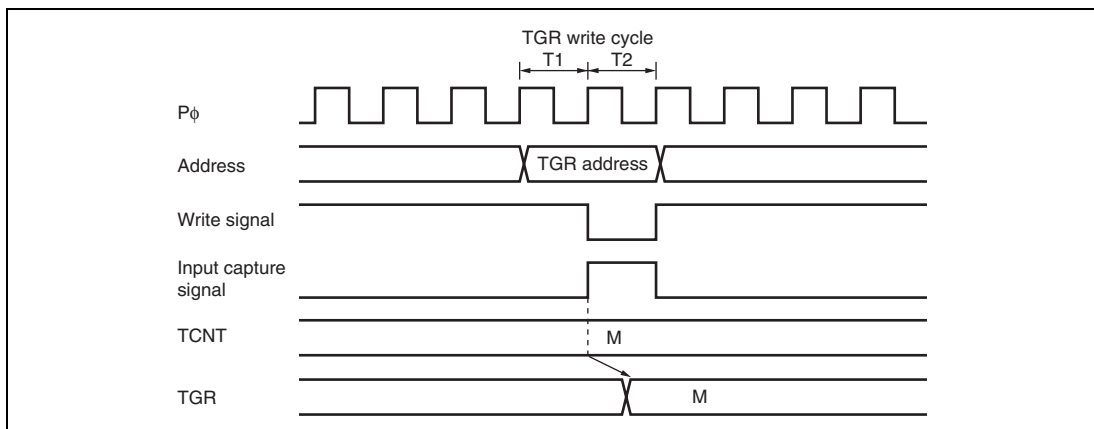

Figure 11.77 Contention between TGR Write and Input Capture

11.7.10 Contention between Buffer Register Write and Input Capture

If an input capture signal is generated in the T2 state of a buffer register write cycle, the buffer operation takes precedence and the write to the buffer register is not performed.

Figure 11.78 shows the timing in this case.

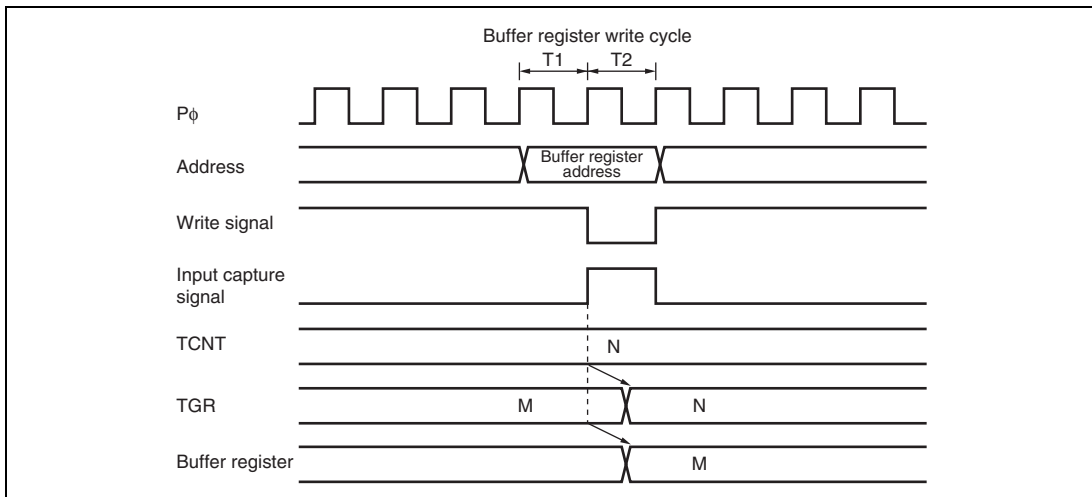

Figure 11.78 Contention between Buffer Register Write and Input Capture

11.7.11 TCNT2 Write and Overflow/Underflow Contention in Cascade Connection

With timer counters TCNT1 and TCNT2 in a cascade connection, when a contention occurs during TCNT₁ count (during a TCNT₂ overflow/underflow) in the T₂ state of the TCNT₂ write cycle, the write to TCNT₂ is conducted, and the TCNT₁ count signal is disabled. At this point, if there is match with TGRA₁ and the TCNT₁ value, a compare signal is issued. Furthermore, when the TCNT₁ count clock is selected as the input capture source of channel 0, TGRA₀ to D₀ carry out the input capture operation. In addition, when the compare match/input capture is selected as the input capture source of TGRB₁, TGRB₁ carries out input capture operation. The timing is shown in figure 11.79.

For cascade connections, be sure to synchronize settings for channels 1 and 2 when setting TCNT clearing.

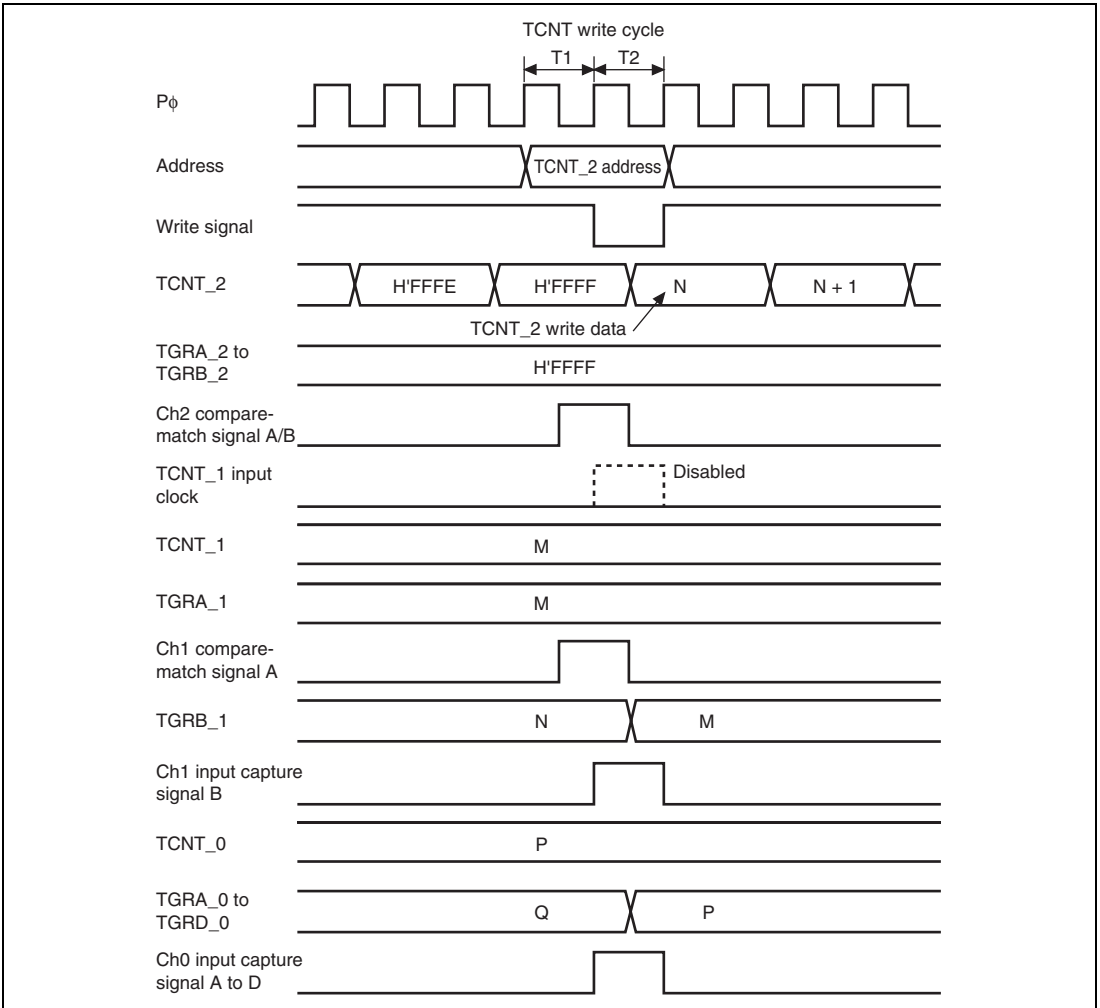

Figure 11.79 TCNT_2 Write and Overflow/Underflow Contention with Cascade Connection

11.7.12 Counter Value during Complementary PWM Mode Stop

When counting operation is suspended with TCNT_3 and TCNT_4 in complementary PWM mode, TCNT_3 has the timer dead time register (TDDR) value, and TCNT_4 is held at H'0000.

When restarting complementary PWM mode, counting begins automatically from the initialized state. This explanatory diagram is shown in figure 11.80.

When counting begins in another operating mode, be sure that TCNT_3 and TCNT_4 are set to the initial values.

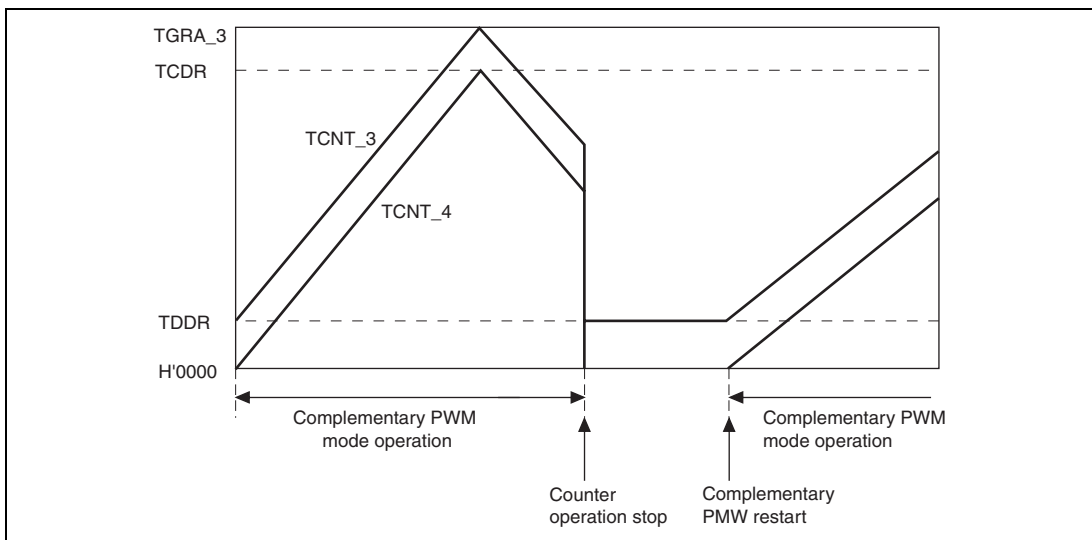

Figure 11.80 Counter Value during Complementary PWM Mode Stop

11.7.13 Buffer Operation Setting in Complementary PWM Mode

In complementary PWM mode, conduct rewrites by buffer operation for the PWM cycle setting register (TGRA_3), timer cycle data register (TCDR), and duty setting registers (TGRB_3, TGRA_4, and TGRB_4).

In complementary PWM mode, channel 3 and channel 4 buffers operate in accordance with bit settings BFA and BFB of TMDR_3. When TMDR_3's BFA bit is set to 1, TGRC_3 functions as a buffer register for TGRA_3. At the same time, TGRC_4 functions as the buffer register for TGRA_4, while the TCBR functions as the TCDR's buffer register.

11.7.14 Reset Sync PWM Mode Buffer Operation and Compare Match Flag

When setting buffer operation for reset sync PWM mode, set the BFA and BFB bits of TMDR_4 to 0. The TIOC4C pin will be unable to produce its waveform output if the BFA bit of TMDR_4 is set to 1.

In reset sync PWM mode, the channel 3 and channel 4 buffers operate in accordance with the BFA and BFB bit settings of TMDR_3. For example, if the BFA bit of TMDR_3 is set to 1, TGRC_3 functions as the buffer register for TGRA_3. At the same time, TGRC_4 functions as the buffer register for TGRA_4.

The TGFC bit and TGFD bit of TSR_3 and TSR_4 are not set when TGRC_3 and TGRD_3 are operating as buffer registers.

Figure 11.81 shows an example of operations for TGR_3, TGR_4, TIOC3, and TIOC4, with TMDR_3's BFA and BFB bits set to 1, and TMDR_4's BFA and BFB bits set to 0.

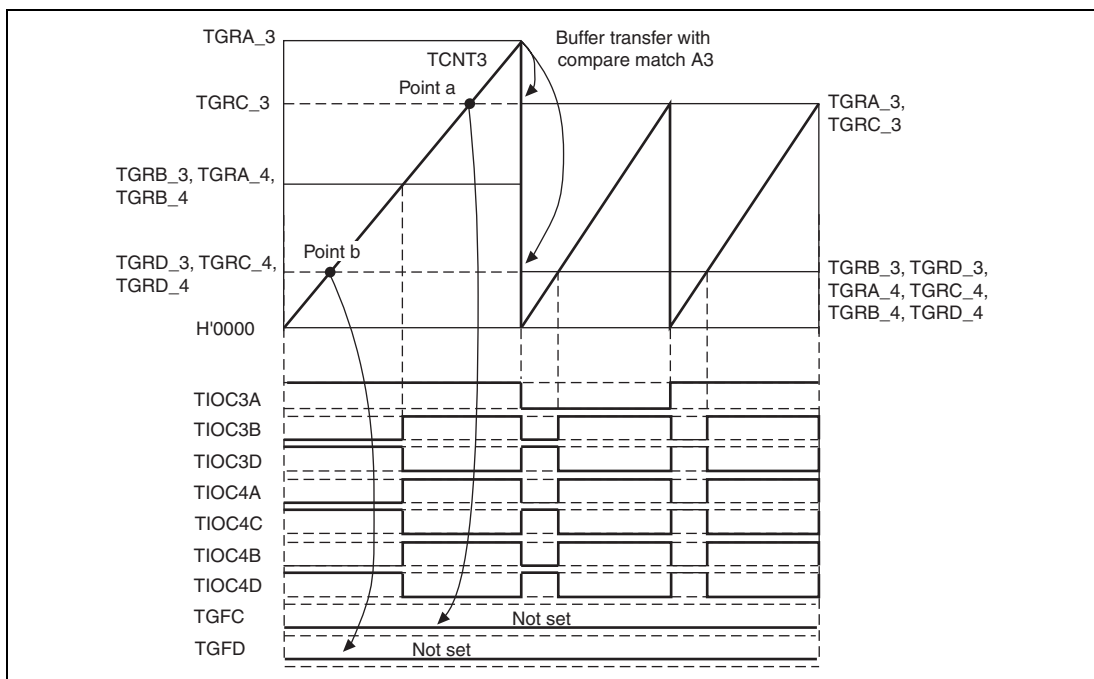

Figure 11.81 Buffer Operation and Compare-Match Flags in Reset Synchronous PWM Mode

11.7.15 Overflow Flags in Reset Synchronous PWM Mode

When set to reset synchronous PWM mode, TCNT_3 and TCNT_4 start counting when the CST3 bit of TSTR is set to 1. At this point, TCNT_4's count clock source and count edge obey the TCR_3 setting.

In reset synchronous PWM mode, with cycle register TGRA_3's set value at H'FFFF, when specifying TGR3A compare-match for the counter clear source, TCNT_3 and TCNT_4 count up to H'FFFF, then a compare-match occurs with TGRA_3, and TCNT_3 and TCNT_4 are both cleared. At this point, TSR's overflow flag TCFV bit is not set.

Figure 11.82 shows a TCFV bit operation example in reset synchronous PWM mode with a set value for cycle register TGRA_3 of H'FFFF, when a TGRA_3 compare-match has been specified without synchronous setting for the counter clear source.

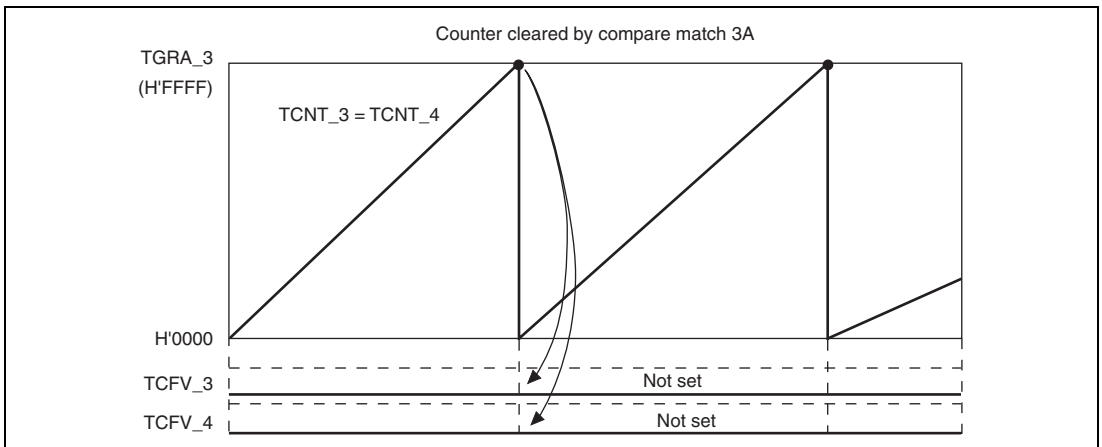

Figure 11.82 Reset Synchronous PWM Mode Overflow Flag

11.7.16 Contention between Overflow/Underflow and Counter Clearing

If overflow/underflow and counter clearing occur simultaneously, the TCFV/TCFU flag in TSR is not set and TCNT clearing takes precedence.

Figure 11.83 shows the operation timing when a TGR compare match is specified as the clearing source, and when H'FFFF is set in TGR.

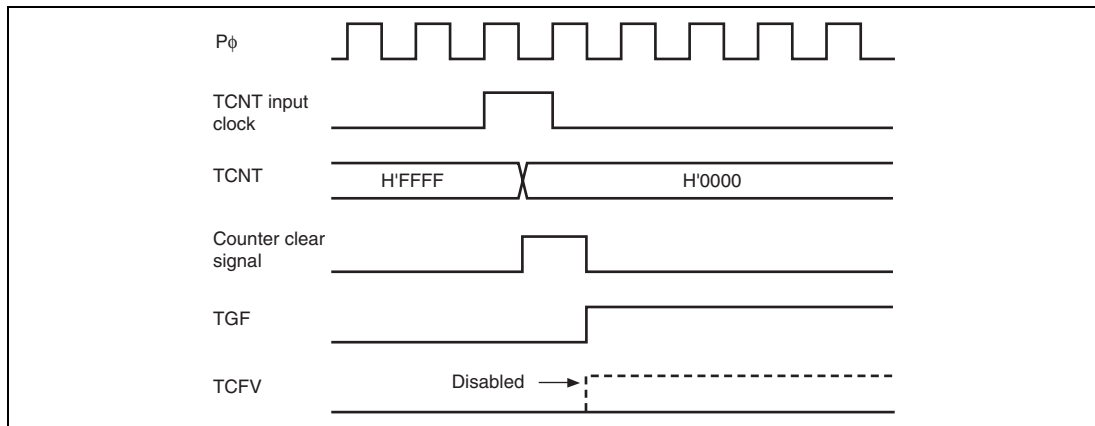

Figure 11.83 Contention between Overflow and Counter Clearing

11.7.17 Contention between TCNT Write and Overflow/Underflow

If there is an up-count or down-count in the T2 state of a TCNT write cycle, and overflow/underflow occurs, the TCNT write takes precedence and the TCFV/TCFU flag in TSR is not set.

Figure 11.84 shows the operation timing when there is contention between TCNT write and overflow.

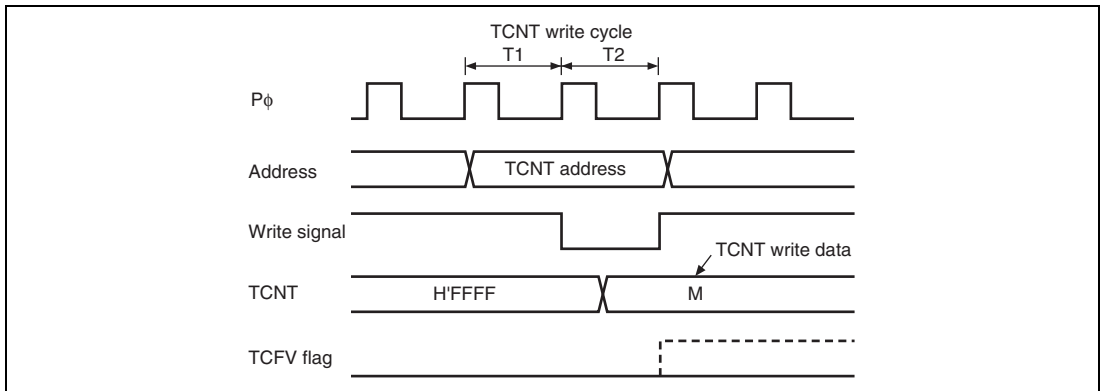

Figure 11.84 Contention between TCNT Write and Overflow

11.7.18 Cautions on Transition from Normal Operation or PWM Mode 1 to Reset-Synchronous PWM Mode

When making a transition from channel 3 or 4 normal operation or PWM mode 1 to reset-synchronous PWM mode, if the counter is halted with the output pins (TIOC3B, TIOC3D, TIOC4A, TIOC4C, TIOC4B, TIOC4D) in the high-impedance state, followed by the transition to reset-synchronous PWM mode and operation in that mode, the initial pin output will not be correct.

When making a transition from normal operation to reset-synchronous PWM mode, write H'11 to registers TIORH_3, TIORL_3, TIORH_4, and TIORL_4 to initialize the output pins to low level output, then set an initial register value of H'00 before making the mode transition.

When making a transition from PWM mode 1 to reset-synchronous PWM mode, first switch to normal operation, then initialize the output pins to low level output and set an initial register value of H'00 before making the transition to reset-synchronous PWM mode.

11.7.19 Output Level in Complementary PWM Mode and Reset-Synchronous PWM Mode

When channels 3 and 4 are in complementary PWM mode or reset-synchronous PWM mode, the PWM waveform output level is set with the OLSP and OLSN bits in the timer output control register (TOCR). In the case of complementary PWM mode or reset-synchronous PWM mode, TIOR should be set to H'00.

11.7.20 Interrupts in Module Standby Mode

If module standby mode is entered when an interrupt has been requested, it will not be possible to clear the CPU interrupt source or the DTC/DMAC activation source. Interrupts should therefore be disabled before entering module standby mode.

11.7.21 Simultaneous Capture of TCNT_1 and TCNT_2 in Cascade Connection

When timer counters 1 and 2 (TCNT_1 and TCNT_2) are operated as a 32-bit counter in cascade connection, the cascade counter value cannot be captured successfully even if input-capture input is simultaneously done to TIOC1A and TIOC2A or to TIOC1B and TIOC2B. This is because the input timing of TIOC1A and TIOC2A or of TIOC1B and TIOC2B may not be the same when external input-capture signals to be input into TCNT_1 and TCNT_2 are taken in synchronization with the internal clock. For example, TCNT_1 (the counter for upper 16 bits) does not capture the count-up value by overflow from TCNT_2 (the counter for lower 16 bits) but captures the count value before the count-up. In this case, the values of TCNT_1 = H'FFF1 and TCNT_2 = H'0000 should be transferred to TGRA_1 and TGRA_2 or to TGRB_1 and TGRB_2, but the values of TCNT_1 = H'FFF0 and TCNT_2 = H'0000 are erroneously transferred.

11.7.22 Note on Buffer Operation Setting

When enabling buffer operation, clear to 0 bits TGIEC and TGIED (corresponding to TGRC and TGRD, which are used as buffer registers) in the timer interrupt enable register (TIER).

11.8 MTU Output Pin Initialization

11.8.1 Operating Modes

The MTU has the following six operating modes. Waveform output is possible in all of these modes.

- Normal mode (channels 0 to 4)
- PWM mode 1 (channels 0 to 4)
- PWM mode 2 (channels 0 to 2)
- Phase counting modes 1 to 4 (channels 1 and 2)
- Complementary PWM mode (channels 3 and 4)
- Reset-synchronous PWM mode (channels 3 and 4)

The MTU output pin initialization method for each of these modes is described in this section.

11.8.2 Reset Start Operation

The MTU output pins (TIOC*) are initialized low by a reset and in standby mode. Since MTU pin function selection is performed by the pin function controller (PFC), when the PFC is set, the MTU pin states at that point are output to the ports. When MTU output is selected by the PFC immediately after a reset, the MTU output initial level, low, is output directly at the port. When the active level is low, the system will operate at this point, and therefore the PFC setting should be made after initialization of the MTU output pins is completed.

Note: Channel number and port notation are substituted for *.

11.8.3 Operation in Case of Re-Setting Due to Error During Operation, Etc.

If an error occurs during MTU operation, MTU output should be cut by the system. Cutoff is performed by switching the pin output to port output with the PFC and outputting the inverse of the active level. For large-current pins, output can also be cut by hardware, using port output enable (POE). The pin initialization procedures for re-setting due to an error during operation, etc., and the procedures for restarting in a different mode after re-setting, are shown below.

The MTU has six operating modes, as stated above. There are thus 36 mode transition combinations, but some transitions are not available with certain channel and mode combinations. Possible mode transition combinations are shown in table 11.43.

Table 11.43 Mode Transition Combinations

| Before | After | | | | | |
|--------|--------|------|------|------|-----------|------|
| | Normal | PWM1 | PWM2 | PCM | CPWM | RPWM |
| Normal | (1) | (2) | (3) | (4) | (5) | (6) |
| PWM1 | (7) | (8) | (9) | (10) | (11) | (12) |
| PWM2 | (13) | (14) | (15) | (16) | None | None |
| PCM | (17) | (18) | (19) | (20) | None | None |
| CPWM | (21) | (22) | None | None | (23) (24) | (25) |
| RPWM | (26) | (27) | None | None | (28) | (29) |

[Legend]

Normal: Normal mode

PWM1: PWM mode 1

PWM2: PWM mode 2

PCM: Phase counting modes 1 to 4

CPWM: Complementary PWM mode

RPWM: Reset-synchronous PWM mode

11.8.4 Overview of Initialization Procedures and Mode Transitions in Case of Error during Operation, etc.

- When making a transition to a mode (Normal, PWM1, PWM2, PCM) in which the pin output level is selected by the timer I/O control register (TIOR) setting, initialize the pins by means of a TIOR setting.
- In PWM mode 1, since a waveform is not output to the TIOC*B (TIOC *D) pin, setting TIOR will not initialize the pins. If initialization is required, carry it out in normal mode, then switch to PWM mode 1.
- In PWM mode 2, since a waveform is not output to the cycle register pin, setting TIOR will not initialize the pins. If initialization is required, carry it out in normal mode, then switch to PWM mode 2.
- In normal mode or PWM mode 2, if TGRC and TGRD operate as buffer registers, setting TIOR will not initialize the buffer register pins. If initialization is required, clear buffer mode, carry out initialization, then set buffer mode again.
- In PWM mode 1, if either TGRC or TGRD operates as a buffer register, setting TIOR will not initialize the TGRC pin. To initialize the TGRC pin, clear buffer mode, carry out initialization, then set buffer mode again.
- When making a transition to a mode (CPWM, RPWM) in which the pin output level is selected by the timer output control register (TOCR) setting, switch to normal mode and perform initialization with TIOR, then restore TIOR to its initial value, and temporarily disable channel 3 and 4 output with the timer output master enable register (TOER). Then operate the unit in accordance with the mode setting procedure (TOCR setting, TMDR setting, TOER setting).

Note: Channel number is substituted for * indicated in this article.

Pin initialization procedures are described below for the numbered combinations in table 11.43. The active level is assumed to be low.

Operation when Error Occurs during Normal Mode Operation, and Operation is Restarted in Normal Mode: Figure 11.85 shows an explanatory diagram of the case where an error occurs in normal mode and operation is restarted in normal mode after re-setting.

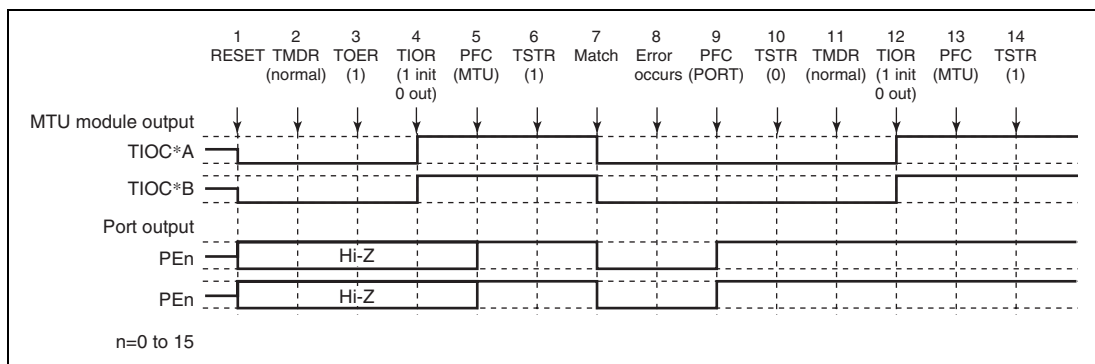

Figure 11.85 Error Occurrence in Normal Mode, Recovery in Normal Mode

1. After a reset, MTU output is low and ports are in the high-impedance state.
2. After a reset, the TMDR setting is for normal mode.
3. For channels 3 and 4, enable output with TOER before initializing the pins with TIOR.
4. Initialize the pins with TIOR. (The example shows initial high output, with low output on compare-match occurrence.)
5. Set MTU output with the PFC.
6. The count operation is started by TSTR.
7. Output goes low on compare-match occurrence.
8. An error occurs.
9. Set port output with the PFC and output the inverse of the active level.
10. Not necessary when restarting in normal mode.
11. The count operation is stopped by TSTR.
12. Initialize the pins with TIOR.
13. Set MTU output with the PFC.
14. Operation is restarted by TSTR.

Operation when Error Occurs during Normal Mode Operation, and Operation is Restarted in PWM Mode 1: Figure 11.86 shows an explanatory diagram of the case where an error occurs in normal mode and operation is restarted in PWM mode 1 after re-setting.

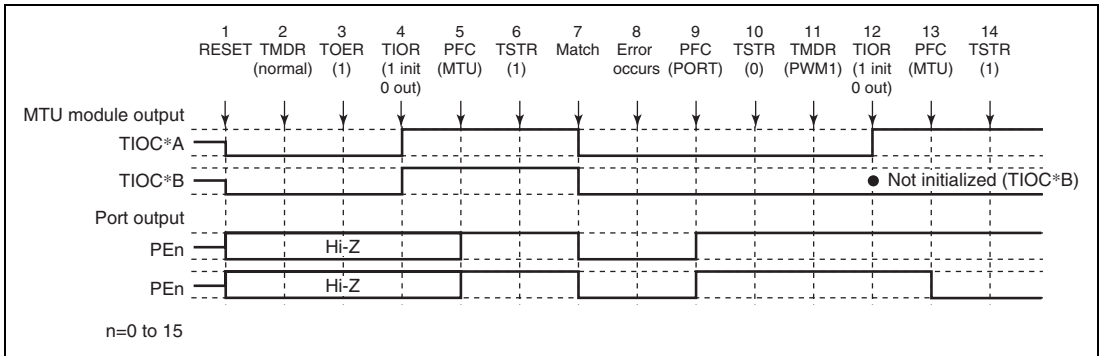

Figure 11.86 Error Occurrence in Normal Mode, Recovery in PWM Mode 1

1 to 10 are the same as in figure 11.85.

11. Set PWM mode 1.
12. Initialize the pins with TIOR. (In PWM mode 1, the TIOC*B side is not initialized. If initialization is required, initialize in normal mode, then switch to PWM mode 1.)
13. Set MTU output with the PFC.
14. Operation is restarted by TSTR.

Operation when Error Occurs during Normal Mode Operation, and Operation is Restarted in PWM Mode 2: Figure 11.87 shows an explanatory diagram of the case where an error occurs in normal mode and operation is restarted in PWM mode 2 after re-setting.

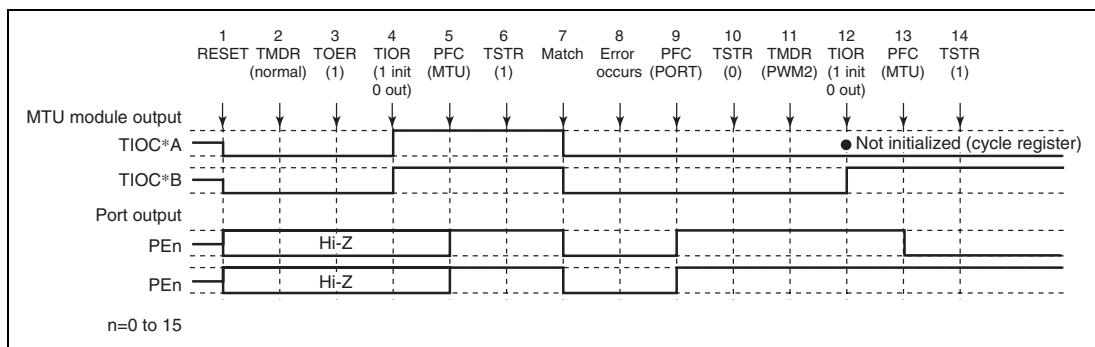

Figure 11.87 Error Occurrence in Normal Mode, Recovery in PWM Mode 2

1 to 10 are the same as in figure 11.85.

11. Set PWM mode 2.
12. Initialize the pins with TIOR. (In PWM mode 2, the cycle register pins are not initialized. If initialization is required, initialize in normal mode, then switch to PWM mode 2.)
13. Set MTU output with the PFC.
14. Operation is restarted by TSTR.

Note: PWM mode 2 can only be set for channels 0 to 2, and therefore TOER setting is not necessary.

Operation when Error Occurs during Normal Mode Operation, and Operation is Restarted in Phase Counting Mode: Figure 11.88 shows an explanatory diagram of the case where an error occurs in normal mode and operation is restarted in phase counting mode after re-setting.

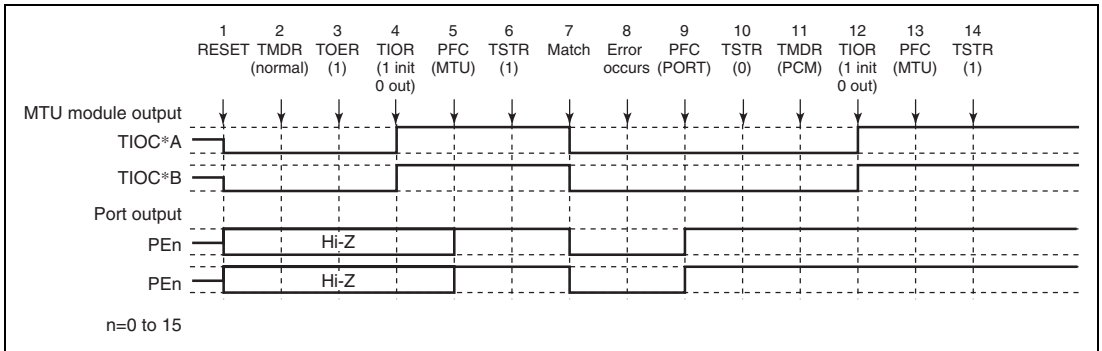

Figure 11.88 Error Occurrence in Normal Mode, Recovery in Phase Counting Mode

1 to 10 are the same as in figure 11.85.

11. Set phase counting mode.
12. Initialize the pins with TIOR.
13. Set MTU output with the PFC.
14. Operation is restarted by TSTR.

Note: Phase counting mode can only be set for channels 1 and 2, and therefore TOER setting is not necessary.

Operation when Error Occurs during Normal Mode Operation, and Operation is Restarted in Complementary PWM Mode: Figure 11.89 shows an explanatory diagram of the case where an error occurs in normal mode and operation is restarted in complementary PWM mode after re-setting.

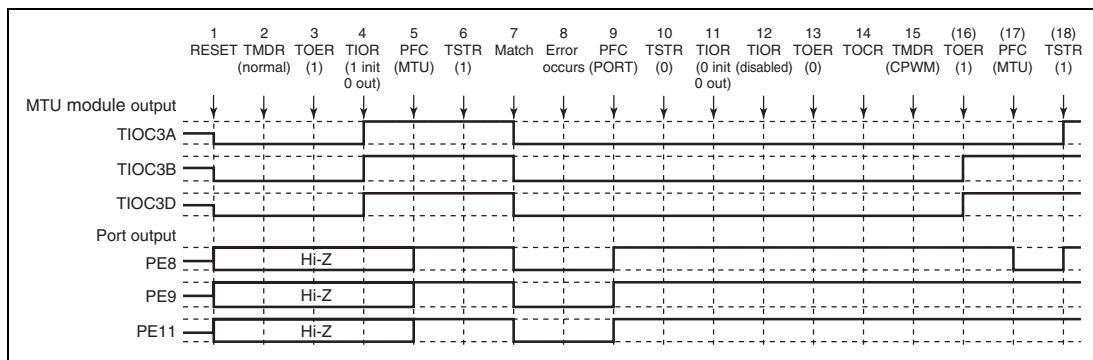

Figure 11.89 Error Occurrence in Normal Mode, Recovery in Complementary PWM Mode

1 to 10 are the same as in figure 11.85.

11. Initialize the normal mode waveform generation section with TIOR.
12. Disable operation of the normal mode waveform generation section with TIOR.
13. Disable channel 3 and 4 output with TOER.
14. Select the complementary PWM output level and cyclic output enabling/disabling with TOCR.
15. Set complementary PWM.
16. Enable channel 3 and 4 output with TOER.
17. Set MTU output with the PFC.
18. Operation is restarted by TSTR.

Operation when Error Occurs during Normal Mode Operation, and Operation is Restarted in Reset-Synchronous PWM Mode: Figure 11.90 shows an explanatory diagram of the case where an error occurs in normal mode and operation is restarted in reset-synchronous PWM mode after re-setting.

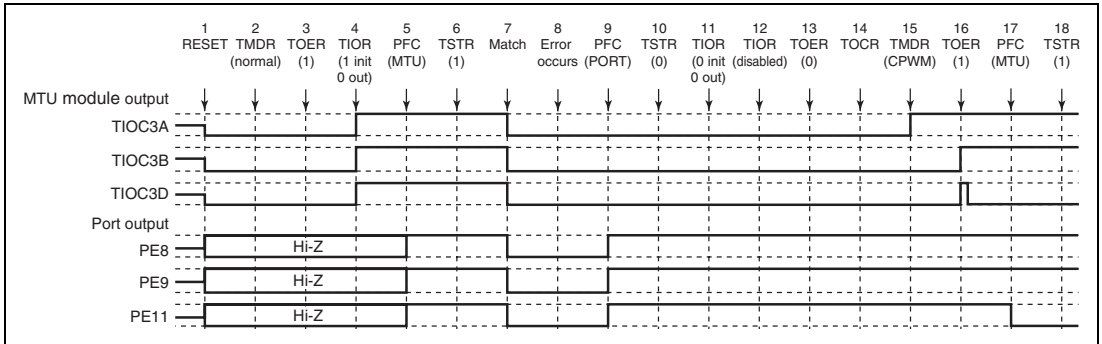

Figure 11.90 Error Occurrence in Normal Mode, Recovery in Reset-Synchronous PWM Mode

1 to 13 are the same as in figure 11.89.

14. Select the reset-synchronous PWM output level and cyclic output enabling/disabling with TOCR.
15. Set reset-synchronous PWM.
16. Enable channel 3 and 4 output with TOER.
17. Set MTU output with the PFC.
18. Operation is restarted by TSTR.

Operation when Error Occurs during PWM Mode 1 Operation, and Operation is Restarted in Normal Mode: Figure 11.91 shows an explanatory diagram of the case where an error occurs in PWM mode 1 and operation is restarted in normal mode after re-setting.

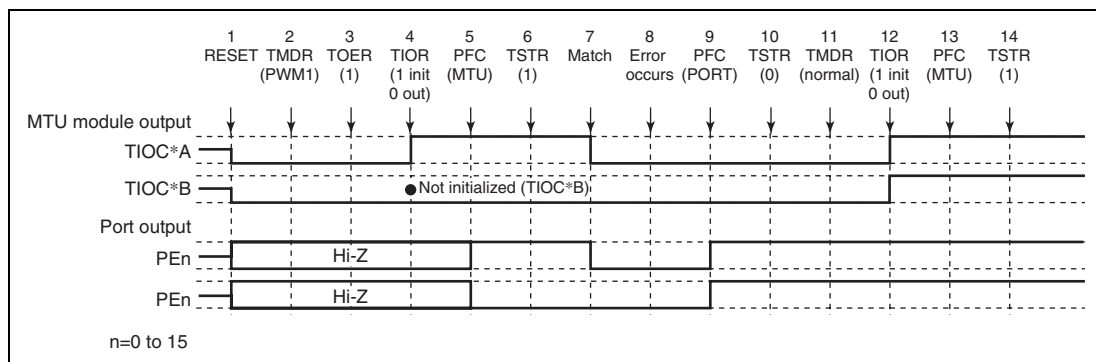

Figure 11.91 Error Occurrence in PWM Mode 1, Recovery in Normal Mode

1. After a reset, MTU output is low and ports are in the high-impedance state.
2. Set PWM mode 1.
3. For channels 3 and 4, enable output with TOER before initializing the pins with TIOR.
4. Initialize the pins with TIOR. (The example shows initial high output, with low output on compare-match occurrence. In PWM mode 1, the TIOC*B side is not initialized.)
5. Set MTU output with the PFC.
6. The count operation is started by TSTR.
7. Output goes low on compare-match occurrence.
8. An error occurs.
9. Set port output with the PFC and output the inverse of the active level.
10. The count operation is stopped by TSTR.
11. Set normal mode.
12. Initialize the pins with TIOR.
13. Set MTU output with the PFC.
14. Operation is restarted by TSTR.

Operation when Error Occurs during PWM Mode 1 Operation, and Operation is Restarted in PWM Mode 1: Figure 11.92 shows an explanatory diagram of the case where an error occurs in PWM mode 1 and operation is restarted in PWM mode 1 after re-setting.

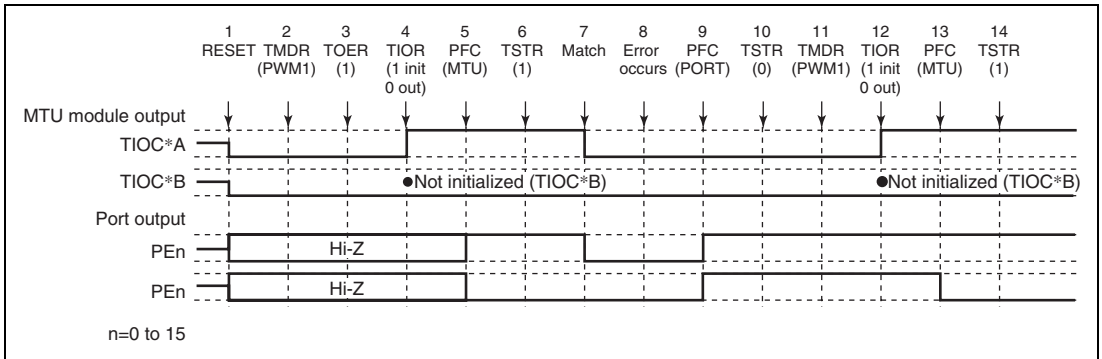

Figure 11.92 Error Occurrence in PWM Mode 1, Recovery in PWM Mode 1

1 to 10 are the same as in figure 11.91.

11. Not necessary when restarting in PWM mode 1.
12. Initialize the pins with TIOR. (In PWM mode 1, the TIOC*B side is not initialized.)
13. Set MTU output with the PFC.
14. Operation is restarted by TSTR.

Operation when Error Occurs during PWM Mode 1 Operation, and Operation is Restarted in PWM Mode 2: Figure 11.93 shows an explanatory diagram of the case where an error occurs in PWM mode 1 and operation is restarted in PWM mode 2 after re-setting.

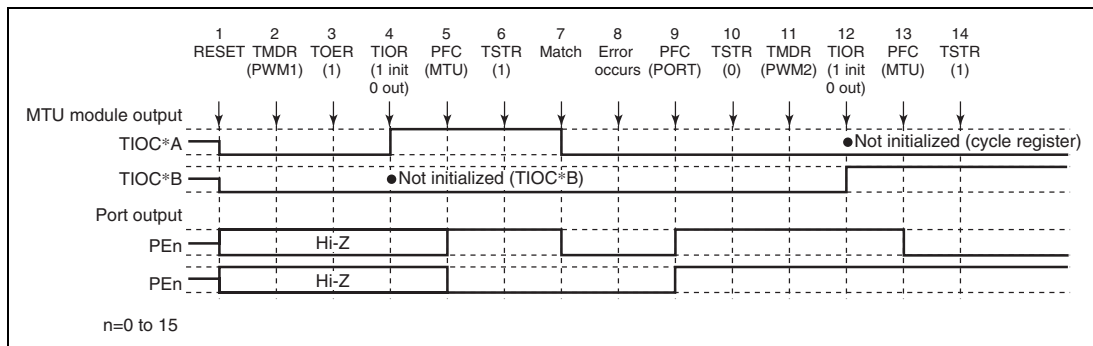

Figure 11.93 Error Occurrence in PWM Mode 1, Recovery in PWM Mode 2

1 to 10 are the same as in figure 11.91.

- Set PWM mode 2.
- Initialize the pins with TIOR. (In PWM mode 2, the cycle register pins are not initialized.)
- Set MTU output with the PFC.
- Operation is restarted by TSTR.

Note: PWM mode 2 can only be set for channels 0 to 2, and therefore TOER setting is not necessary.

Operation when Error Occurs during PWM Mode 1 Operation, and Operation is Restarted in Phase Counting Mode: Figure 11.94 shows an explanatory diagram of the case where an error occurs in PWM mode 1 and operation is restarted in phase counting mode after re-setting.

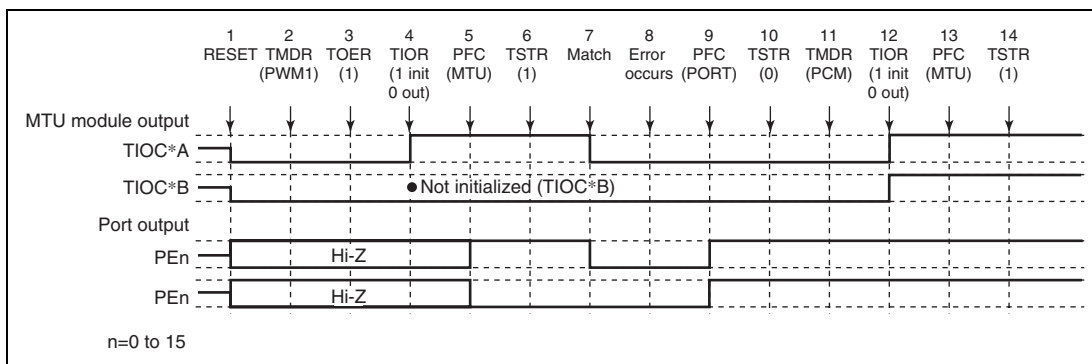

Figure 11.94 Error Occurrence in PWM Mode 1, Recovery in Phase Counting Mode

1 to 10 are the same as in figure 11.91.

11. Set phase counting mode.
12. Initialize the pins with TIOR.
13. Set MTU output with the PFC.
14. Operation is restarted by TSTR.

Note: Phase counting mode can only be set for channels 1 and 2, and therefore TOER setting is not necessary.

Operation when Error Occurs during PWM Mode 1 Operation, and Operation is Restarted in Complementary PWM Mode: Figure 11.95 shows an explanatory diagram of the case where an error occurs in PWM mode 1 and operation is restarted in complementary PWM mode after re-setting.

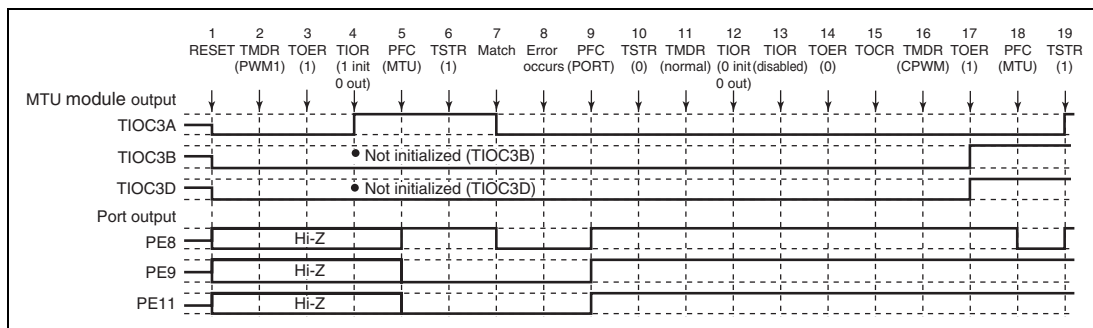

Figure 11.95 Error Occurrence in PWM Mode 1, Recovery in Complementary PWM Mode

1 to 10 are the same as in figure 11.91.

11. Set normal mode for initialization of the normal mode waveform generation section.
12. Initialize the PWM mode 1 waveform generation section with TIOR.
13. Disable operation of the PWM mode 1 waveform generation section with TIOR.
14. Disable channel 3 and 4 output with TOER.
15. Select the complementary PWM output level and cyclic output enabling/disabling with TOCR.
16. Set complementary PWM.
17. Enable channel 3 and 4 output with TOER.
18. Set MTU output with the PFC.
19. Operation is restarted by TSTR.

Operation when Error Occurs during PWM Mode 1 Operation, and Operation is Restarted in Reset-Synchronous PWM Mode: Figure 11.96 shows an explanatory diagram of the case where an error occurs in PWM mode 1 and operation is restarted in reset-synchronous PWM mode after re-setting.

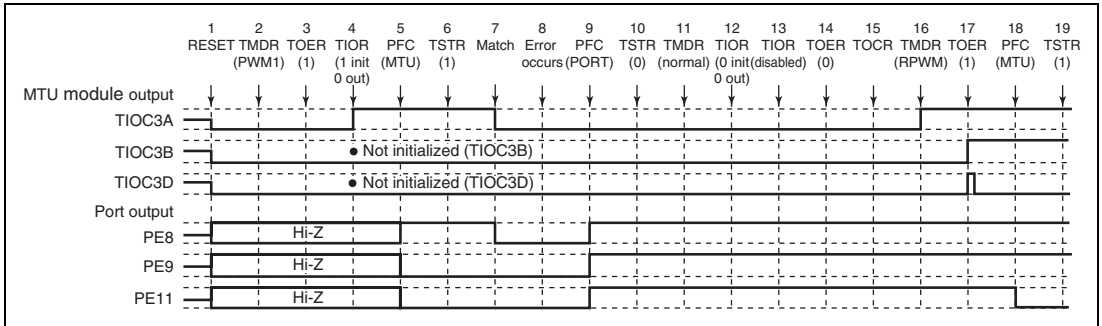

Figure 11.96 Error Occurrence in PWM Mode 1, Recovery in Reset-Synchronous PWM Mode

1 to 14 are the same as in figure 11.95.

15. Select the reset-synchronous PWM output level and cyclic output enabling/disabling with TOCR.
16. Set reset-synchronous PWM.
17. Enable channel 3 and 4 output with TOER.
18. Set MTU output with the PFC.
19. Operation is restarted by TSTR.

Operation when Error Occurs during PWM Mode 2 Operation, and Operation is Restarted in Normal Mode: Figure 11.97 shows an explanatory diagram of the case where an error occurs in PWM mode 2 and operation is restarted in normal mode after re-setting.

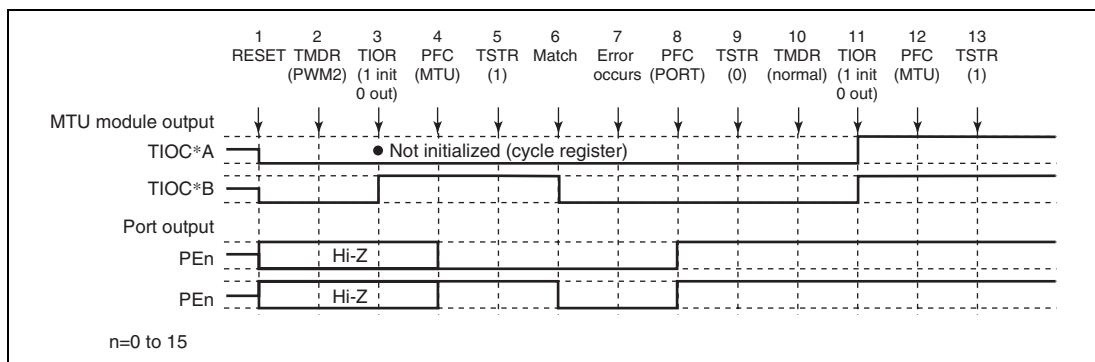

Figure 11.97 Error Occurrence in PWM Mode 2, Recovery in Normal Mode

1. After a reset, MTU output is low and ports are in the high-impedance state.
2. Set PWM mode 2.
3. Initialize the pins with TIOR. (The example shows initial high output, with low output on compare-match occurrence. In PWM mode 2, the cycle register pins are not initialized. In the example, TIOC *A is the cycle register.)
4. Set MTU output with the PFC.
5. The count operation is started by TSTR.
6. Output goes low on compare-match occurrence.
7. An error occurs.
8. Set port output with the PFC and output the inverse of the active level.
9. The count operation is stopped by TSTR.
10. Set normal mode.
11. Initialize the pins with TIOR.
12. Set MTU output with the PFC.
13. Operation is restarted by TSTR.

Operation when Error Occurs during PWM Mode 2 Operation, and Operation is Restarted in PWM Mode 1: Figure 11.98 shows an explanatory diagram of the case where an error occurs in PWM mode 2 and operation is restarted in PWM mode 1 after re-setting.

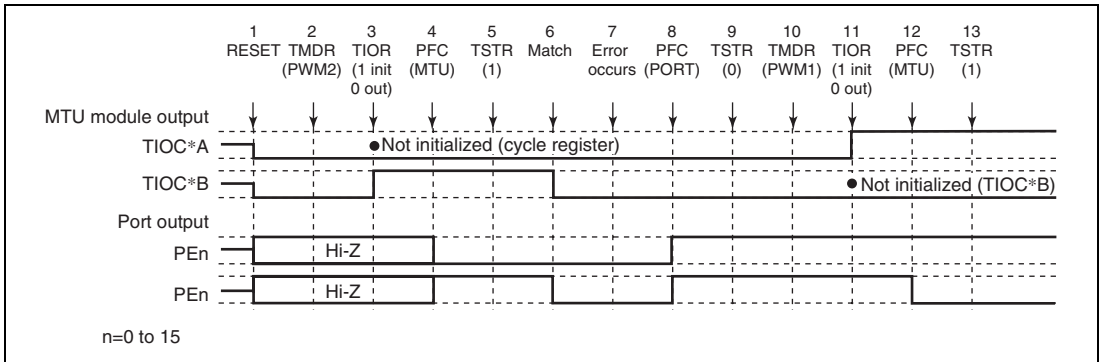

Figure 11.98 Error Occurrence in PWM Mode 2, Recovery in PWM Mode 1

1 to 9 are the same as in figure 11.97.

10. Set PWM mode 1.
11. Initialize the pins with TIOR. (In PWM mode 1, the TIOC*B side is not initialized.)
12. Set MTU output with the PFC.
13. Operation is restarted by TSTR.

Operation when Error Occurs during PWM Mode 2 Operation, and Operation is Restarted in PWM Mode 2: Figure 11.99 shows an explanatory diagram of the case where an error occurs in PWM mode 2 and operation is restarted in PWM mode 2 after re-setting.

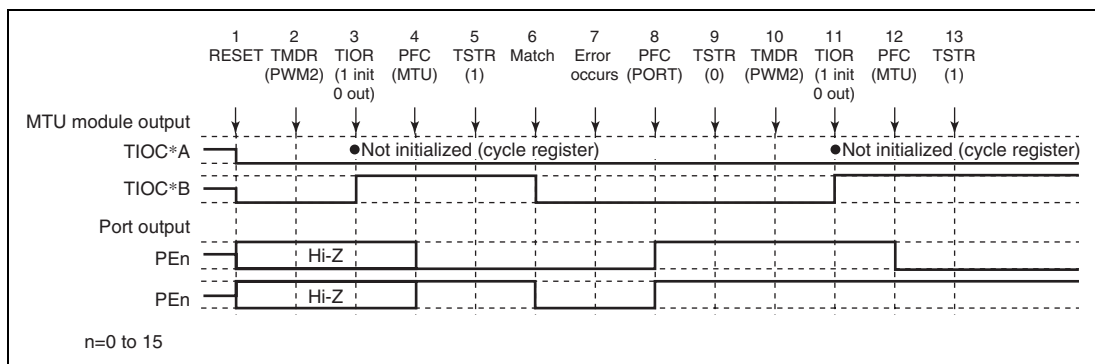

Figure 11.99 Error Occurrence in PWM Mode 2, Recovery in PWM Mode 2

1 to 9 are the same as in figure 11.97.

10. Not necessary when restarting in PWM mode 2.

11. Initialize the pins with TIOR. (In PWM mode 2, the cycle register pins are not initialized.)

12. Set MTU output with the PFC.

13. Operation is restarted by TSTR.

Operation when Error Occurs during PWM Mode 2 Operation, and Operation is Restarted in Phase Counting Mode: Figure 11.100 shows an explanatory diagram of the case where an error occurs in PWM mode 2 and operation is restarted in phase counting mode after re-setting.

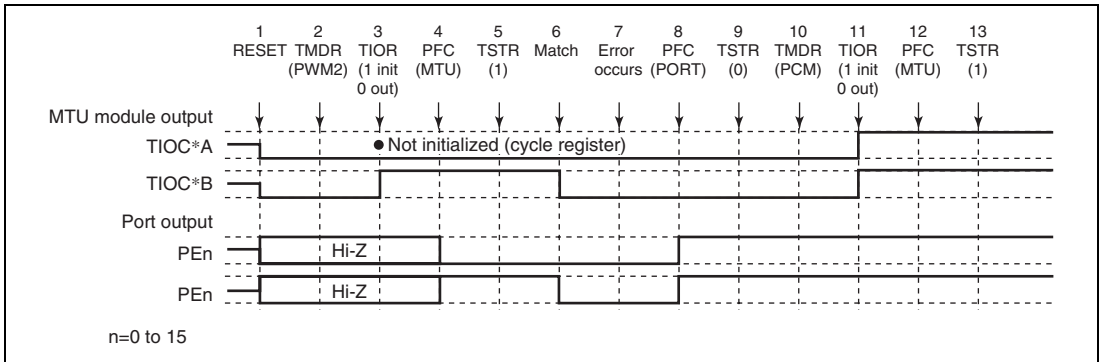

Figure 11.100 Error Occurrence in PWM Mode 2, Recovery in Phase Counting Mode

1 to 9 are the same as in figure 11.97.

10. Set phase counting mode.
11. Initialize the pins with TIOR.
12. Set MTU output with the PFC.
13. Operation is restarted by TSTR.

Operation when Error Occurs during Phase Counting Mode Operation, and Operation is Restarted in Normal Mode: Figure 11.101 shows an explanatory diagram of the case where an error occurs in phase counting mode and operation is restarted in normal mode after re-setting.

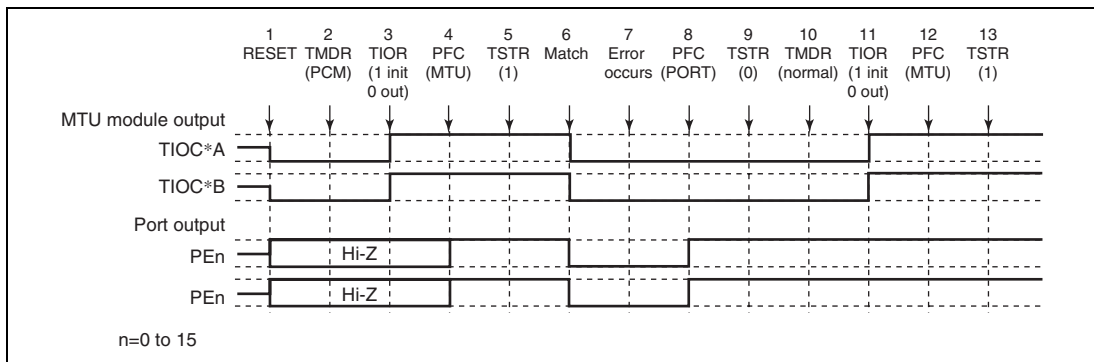

Figure 11.101 Error Occurrence in Phase Counting Mode, Recovery in Normal Mode

1. After a reset, MTU output is low and ports are in the high-impedance state.
2. Set phase counting mode.
3. Initialize the pins with TIOR. (The example shows initial high output, with low output on compare-match occurrence.)
4. Set MTU output with the PFC.
5. The count operation is started by TSTR.
6. Output goes low on compare-match occurrence.
7. An error occurs.
8. Set port output with the PFC and output the inverse of the active level.
9. The count operation is stopped by TSTR.
10. Set in normal mode.
11. Initialize the pins with TIOR.
12. Set MTU output with the PFC.
13. Operation is restarted by TSTR.

Operation when Error Occurs during Phase Counting Mode Operation, and Operation is Restarted in PWM Mode 1: Figure 11.102 shows an explanatory diagram of the case where an error occurs in phase counting mode and operation is restarted in PWM mode 1 after re-setting.

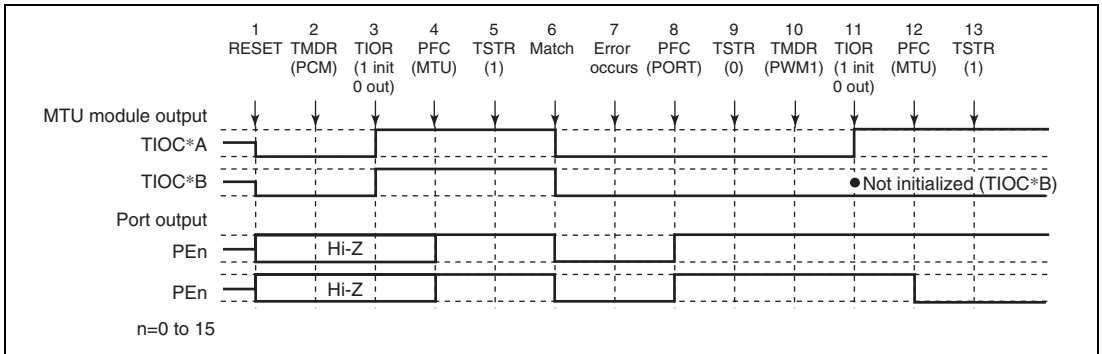

Figure 11.102 Error Occurrence in Phase Counting Mode, Recovery in PWM Mode 1

1 to 9 are the same as in figure 11.101.

10. Set PWM mode 1.

11. Initialize the pins with TIOR. (In PWM mode 1, the TIOC *B side is not initialized.)

12. Set MTU output with the PFC.

13. Operation is restarted by TSTR.

Operation when Error Occurs during Phase Counting Mode Operation, and Operation is Restarted in PWM Mode 2: Figure 11.103 shows an explanatory diagram of the case where an error occurs in phase counting mode and operation is restarted in PWM mode 2 after re-setting.

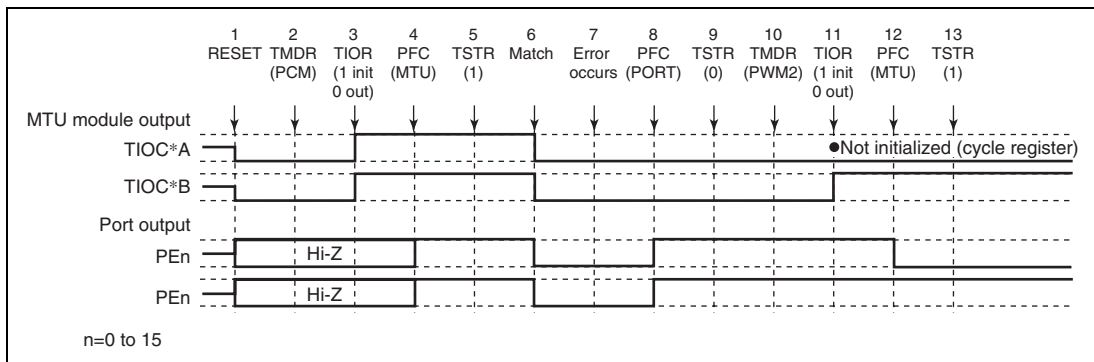

Figure 11.103 Error Occurrence in Phase Counting Mode, Recovery in PWM Mode 2

1 to 9 are the same as in figure 11.101.

10. Set PWM mode 2.
11. Initialize the pins with TIOR. (In PWM mode 2, the cycle register pins are not initialized.)
12. Set MTU output with the PFC.
13. Operation is restarted by TSTR.

Operation when Error Occurs during Phase Counting Mode Operation, and Operation is Restarted in Phase Counting Mode: Figure 11.104 shows an explanatory diagram of the case where an error occurs in phase counting mode and operation is restarted in phase counting mode after re-setting.

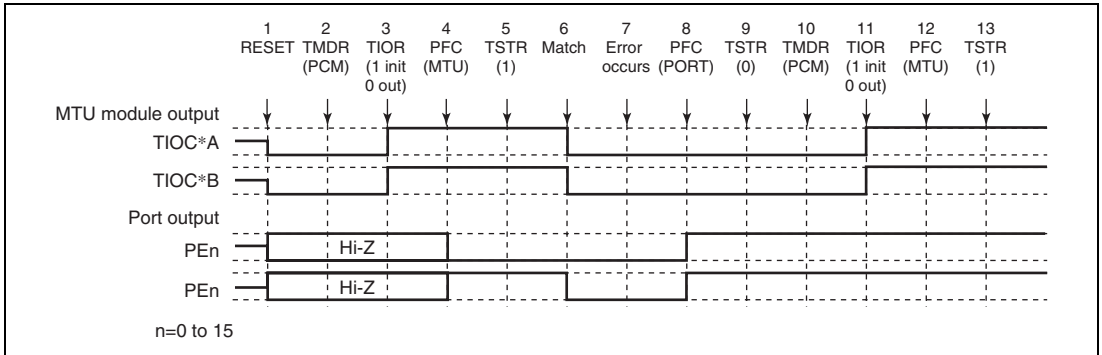

Figure 11.104 Error Occurrence in Phase Counting Mode, Recovery in Phase Counting Mode

1 to 9 are the same as in figure 11.101.

10. Not necessary when restarting in phase counting mode.
11. Initialize the pins with TIOR.
12. Set MTU output with the PFC.
13. Operation is restarted by TSTR.

Operation when Error Occurs during Complementary PWM Mode Operation, and

Operation is Restarted in Normal Mode: Figure 11.105 shows an explanatory diagram of the case where an error occurs in complementary PWM mode and operation is restarted in normal mode after re-setting.

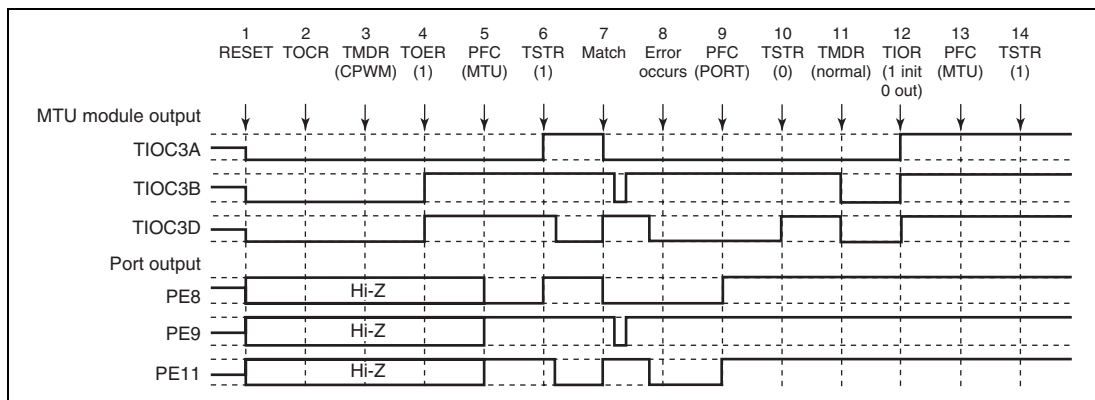

Figure 11.105 Error Occurrence in Complementary PWM Mode, Recovery in Normal Mode

1. After a reset, MTU output is low and ports are in the high-impedance state.
2. Select the complementary PWM output level and cyclic output enabling/disabling with TOCR.
3. Set complementary PWM.
4. Enable channel 3 and 4 output with TOER.
5. Set MTU output with the PFC.
6. The count operation is started by TSTR.
7. The complementary PWM waveform is output on compare-match occurrence.
8. An error occurs.
9. Set port output with the PFC and output the inverse of the active level.
10. The count operation is stopped by TSTR. (MTU output becomes the complementary PWM output initial value.)
11. Set normal mode. (MTU output goes low.)
12. Initialize the pins with TIOR.
13. Set MTU output with the PFC.
14. Operation is restarted by TSTR.

Operation when Error Occurs during Complementary PWM Mode Operation, and Operation is Restarted in PWM Mode 1: Figure 11.106 shows an explanatory diagram of the case where an error occurs in complementary PWM mode and operation is restarted in PWM mode 1 after re-setting.

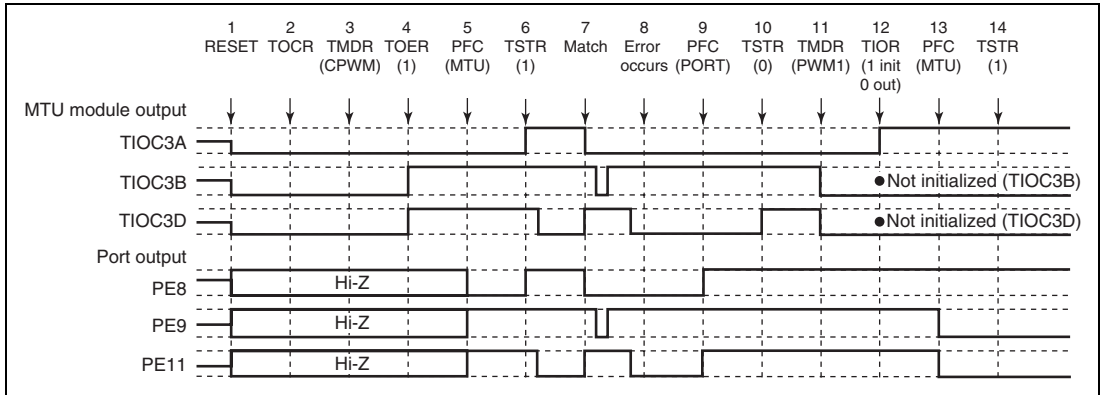

Figure 11.106 Error Occurrence in Complementary PWM Mode, Recovery in PWM Mode 1

1 to 10 are the same as in figure 11.105.

11. Set PWM mode 1. (MTU output goes low.)
12. Initialize the pins with TIOR. (In PWM mode 1, the TIOC *B side is not initialized.)
13. Set MTU output with the PFC.
14. Operation is restarted by TSTR.

Operation when Error Occurs during Complementary PWM Mode Operation, and Operation is Restarted in Complementary PWM Mode: Figure 11.107 shows an explanatory diagram of the case where an error occurs in complementary PWM mode and operation is restarted in complementary PWM mode after re-setting (when operation is restarted using the cycle and duty settings at the time the counter was stopped).

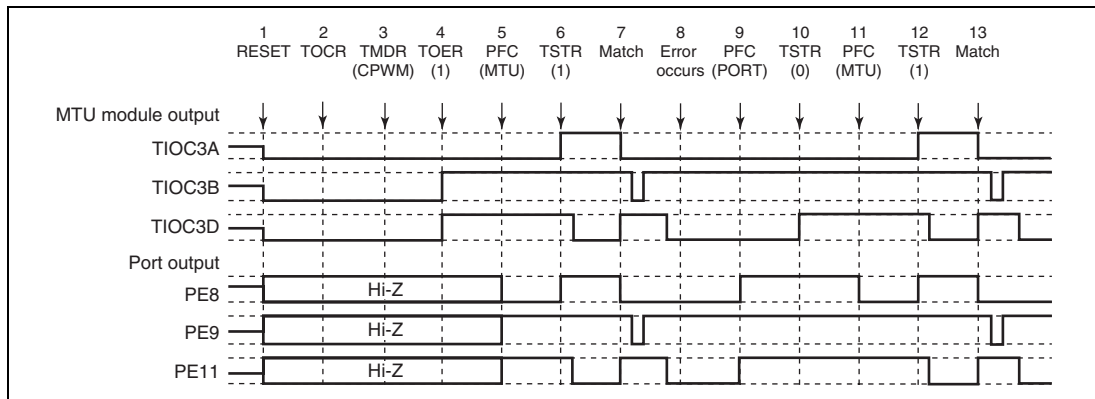

Figure 11.107 Error Occurrence in Complementary PWM Mode, Recovery in Complementary PWM Mode

1 to 10 are the same as in figure 11.105.

11. Set MTU output with the PFC.
12. Operation is restarted by TSTR.
13. The complementary PWM waveform is output on compare-match occurrence.

Operation when Error Occurs during Complementary PWM Mode Operation, and Operation is Restarted in Complementary PWM Mode: Figure 11.108 shows an explanatory diagram of the case where an error occurs in complementary PWM mode and operation is restarted in complementary PWM mode after re-setting (when operation is restarted using completely new cycle and duty settings).

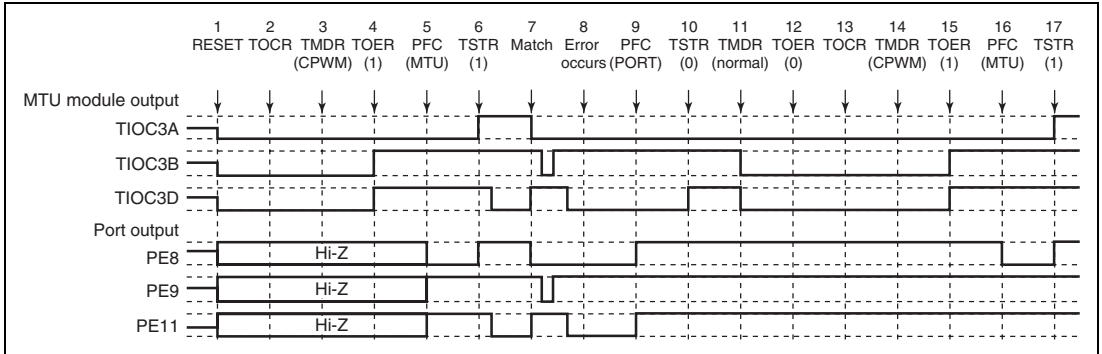

Figure 11.108 Error Occurrence in Complementary PWM Mode, Recovery in Complementary PWM Mode

1 to 10 are the same as in figure 11.105.

- Set normal mode and make new settings. (MTU output goes low.)
- Disable channel 3 and 4 output with TOER.
- Select the complementary PWM mode output level and cyclic output enabling/disabling with TOCR.
- Set complementary PWM.
- Enable channel 3 and 4 output with TOER.
- Set MTU output with the PFC.
- Operation is restarted by TSTR.

Operation when Error Occurs during Complementary PWM Mode Operation, and Operation is Restarted in Reset-Synchronous PWM Mode: Figure 11.109 shows an explanatory diagram of the case where an error occurs in complementary PWM mode and operation is restarted in reset-synchronous PWM mode.

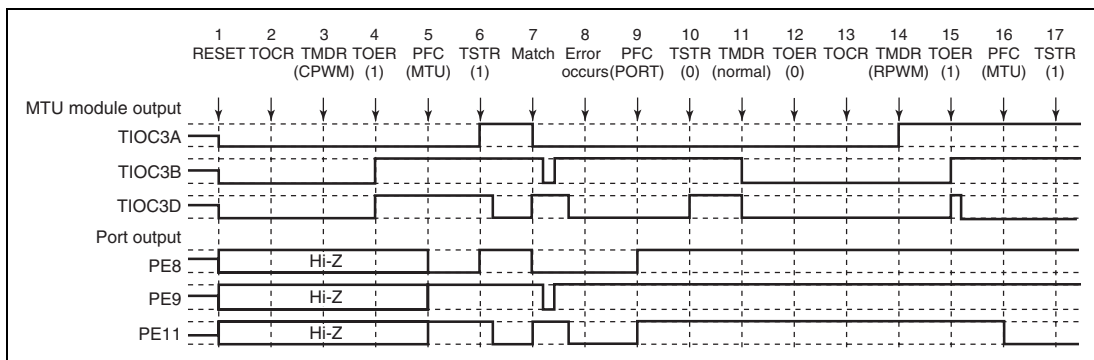

Figure 11.109 Error Occurrence in Complementary PWM Mode, Recovery in Reset-Synchronous PWM Mode

1 to 10 are the same as in figure 11.105.

11. Set normal mode. (MTU output goes low.)
12. Disable channel 3 and 4 output with TOER.
13. Select the reset-synchronous PWM mode output level and cyclic output enabling/disabling with TOCR.
14. Set reset-synchronous PWM.
15. Enable channel 3 and 4 output with TOER.
16. Set MTU output with the PFC.
17. Operation is restarted by TSTR.

Operation when Error Occurs during Reset-Synchronous PWM Mode Operation, and Operation is Restarted in Normal Mode: Figure 11.110 shows an explanatory diagram of the case where an error occurs in reset-synchronous PWM mode and operation is restarted in normal mode after re-setting.

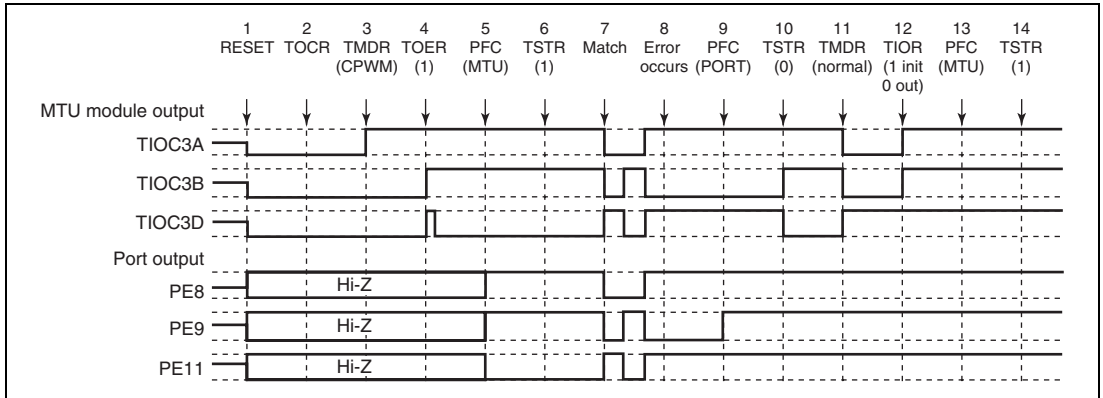

Figure 11.110 Error Occurrence in Reset-Synchronous PWM Mode, Recovery in Normal Mode

1. After a reset, MTU output is low and ports are in the high-impedance state.
2. Select the reset-synchronous PWM output level and cyclic output enabling/disabling with TOCR.
3. Set reset-synchronous PWM.
4. Enable channel 3 and 4 output with TOER.
5. Set MTU output with the PFC.
6. The count operation is started by TSTR.
7. The reset-synchronous PWM waveform is output on compare-match occurrence.
8. An error occurs.
9. Set port output with the PFC and output the inverse of the active level.
10. The count operation is stopped by TSTR. (MTU output becomes the reset-synchronous PWM output initial value.)
11. Set normal mode. (MTU positive phase output is low, and negative phase output is high.)
12. Initialize the pins with TIOR.
13. Set MTU output with the PFC.
14. Operation is restarted by TSTR.

Operation when Error Occurs during Reset-Synchronous PWM Mode Operation, and Operation is Restarted in PWM Mode 1: Figure 11.111 shows an explanatory diagram of the case where an error occurs in reset-synchronous PWM mode and operation is restarted in PWM mode 1 after re-setting.

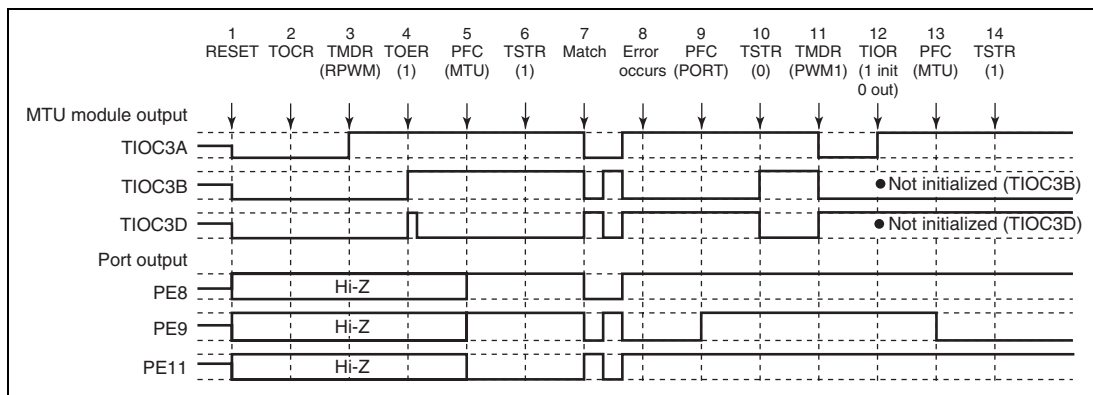

Figure 11.111 Error Occurrence in Reset-Synchronous PWM Mode, Recovery in PWM Mode 1

1 to 10 are the same as in figure 11.110.

11. Set PWM mode 1. (MTU positive phase output is low, and negative phase output is high.)
12. Initialize the pins with TIOR. (In PWM mode 1, the TIOC *B side is not initialized.)
13. Set MTU output with the PFC.
14. Operation is restarted by TSTR.

Operation when Error Occurs during Reset-Synchronous PWM Mode Operation, and Operation is Restarted in Complementary PWM Mode: Figure 11.112 shows an explanatory diagram of the case where an error occurs in reset-synchronous PWM mode and operation is restarted in complementary PWM mode after re-setting.

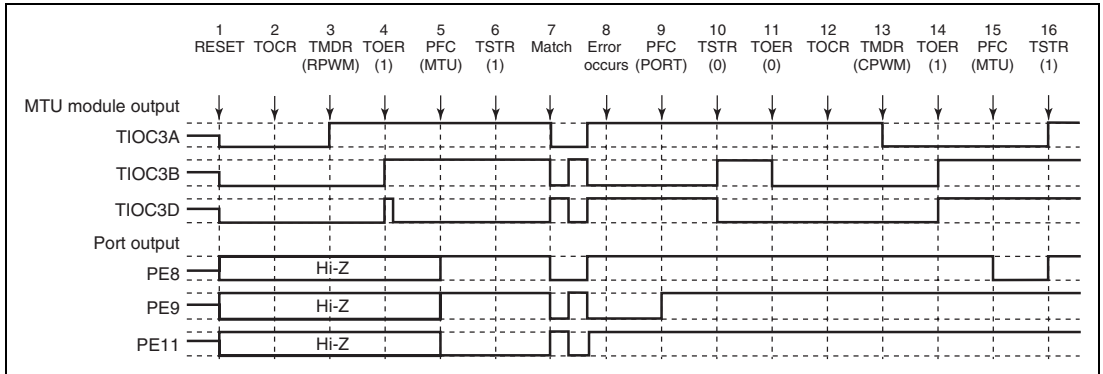

Figure 11.112 Error Occurrence in Reset-Synchronous PWM Mode, Recovery in Complementary PWM Mode

1 to 10 are the same as in figure 11.110.

11. Disable channel 3 and 4 output with TOER.
12. Select the complementary PWM output level and cyclic output enabling/disabling with TOCR.
13. Set complementary PWM. (The MTU cyclic output pin goes low.)
14. Enable channel 3 and 4 output with TOER.
15. Set MTU output with the PFC.
16. Operation is restarted by TSTR.

Operation when Error Occurs during Reset-Synchronous PWM Mode Operation, and Operation is Restarted in Reset-Synchronous PWM Mode: Figure 11.113 shows an explanatory diagram of the case where an error occurs in reset-synchronous PWM mode and operation is restarted in reset-synchronous PWM mode after re-setting.

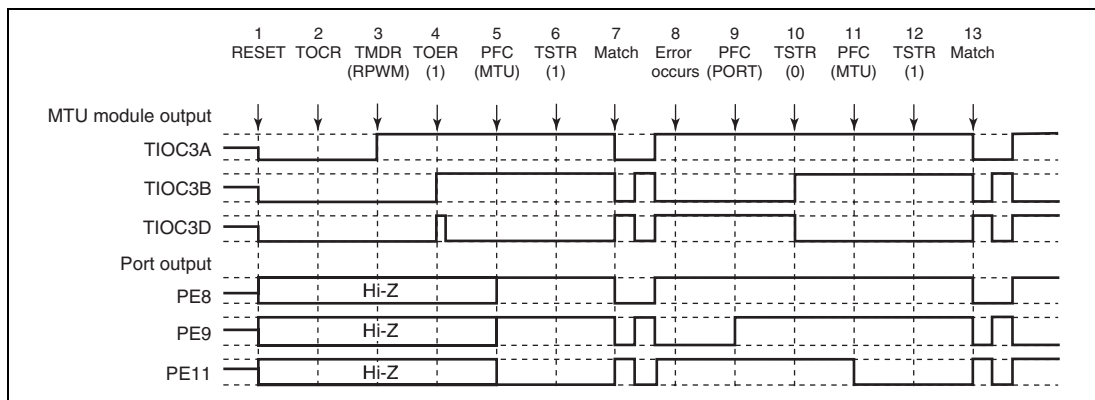

Figure 11.113 Error Occurrence in Reset-Synchronous PWM Mode, Recovery in Reset-Synchronous PWM Mode

1 to 10 are the same as in figure 11.110.

11. Set MTU output with the PFC.
12. Operation is restarted by TSTR.
13. The reset-synchronous PWM waveform is output on compare-match occurrence.

11.9 Port Output Enable (POE)

The port output enable (POE) can be used to establish a high-impedance state for high-current pins, by changing the $\overline{POE0}$ to $\overline{POE3}$ pin input, depending on the output status of the high-current pins (PE9/TIOC3B/SCK3/ \overline{TRST} *, PE11/TIOC3D/RXD3/TDO*, PE12/TIOC4A/TXD3/TCK*, PE13/TIOC4B/ \overline{MRES} , PE14/TIOC4C/DACK0, PE15/TIOC4D/DACK1/ \overline{IRQOUT}). It can also simultaneously generate interrupt requests.

The high-current pins can also be set to high-impedance regardless of whether these pin functions are selected in cases such as when the oscillator stops or in software standby mode. For details, refer to section 17.1.11, High-Current Port Control Register (PPCR).

However, when using the E10A, the high-impedance function is disabled when an oscillation stop is detected, port output enable (POE), or in the software standby state for the three pins of PE9/TIOC3B/SCK3/ \overline{TRST} , PE11/TIOC3D/RXD3/TDO, and PE12/TIOC4A/TXD3/TCK of the SH7145.

Note: * Only in the SH7145.

11.9.1 Features

- Each of the $\overline{POE0}$ to $\overline{POE3}$ input pins can be set for falling edge, $P\phi/8 \times 16$, $P\phi/16 \times 16$, or $P\phi/128 \times 16$ low-level sampling.
- High-current pins can be set to high-impedance state by $\overline{POE0}$ to $\overline{POE3}$ pin falling-edge or low-level sampling.
- High-current pins can be set to high-impedance state when the high-current pin output levels are compared and simultaneous low-level output continues for one cycle or more.
- Interrupts can be generated by input-level sampling or output-level comparison results.

The POE has input-level detection circuitry and output-level detection circuitry, as shown in the block diagram of figure 11.114.

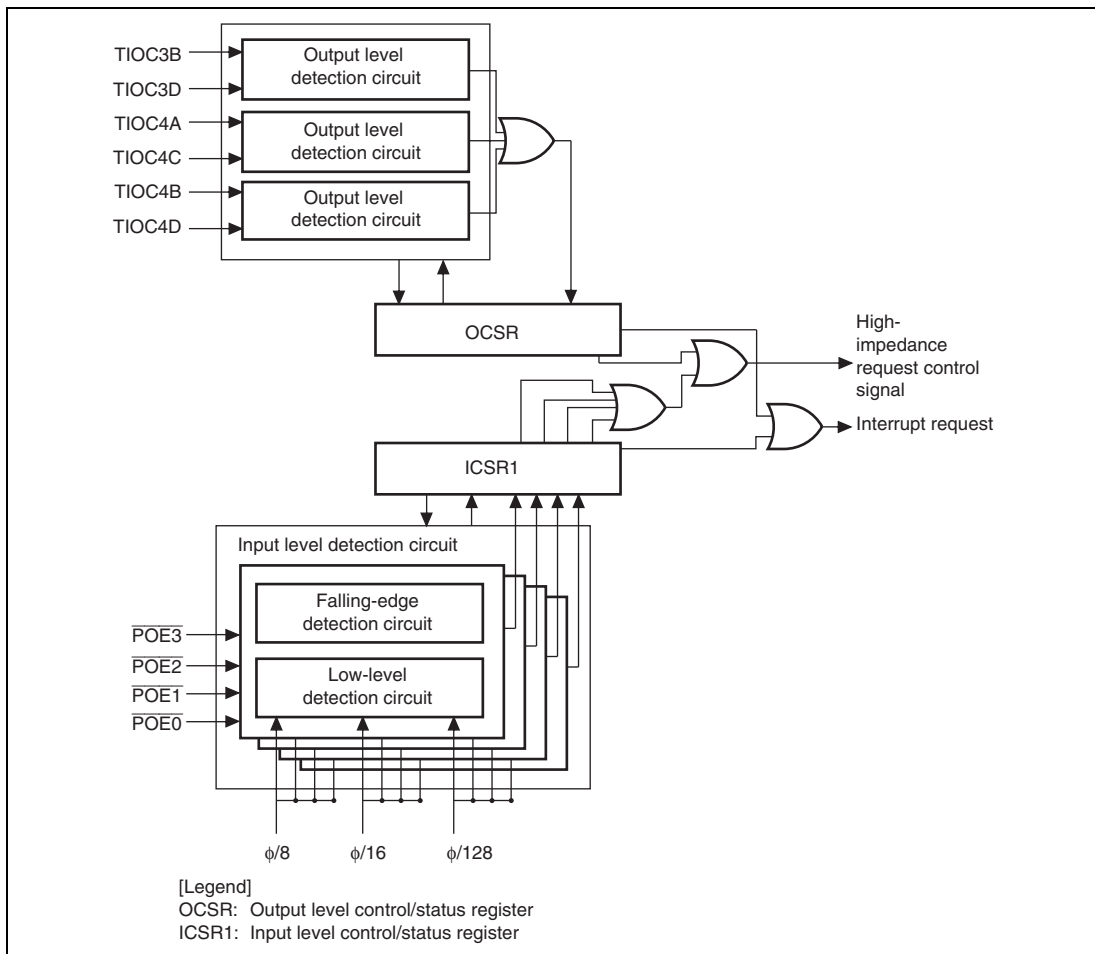

Figure 11.114 POE Block Diagram

11.9.2 Pin Configuration

Table 11.44 Pin Configuration

| Name | Abbreviation | I/O | Description |
|-------------------------------|--|-------|--|
| Port output enable input pins | $\overline{POE0}$ to $\overline{POE3}$ | Input | Input request signals to make high-current pins high-impedance state |

Table 11.45 shows output-level comparisons with pin combinations.

Table 11.45 Pin Combinations

| Pin Combination | I/O | Description |
|---|--------|--|
| PE9/TIOC3B and PE11/TIOC3D | Output | All high-current pins are made high-impedance state when the pins simultaneously output low-level for longer than 1 cycle. |
| PE12/TIOC4A and PE14/TIOC4C | Output | All high-current pins are made high-impedance state when the pins simultaneously output low-level for longer than 1 cycle. |
| PE13/TIOC4B/ \overline{MRES} and PE15/TIOC4D/ \overline{IRQOUT} | Output | All high-current pins are made high-impedance state when the pins simultaneously output low-level for longer than 1 cycle. |

11.9.3 Register Descriptions

The POE has the two registers. The input level control/status register 1 (ICSR1) controls both $\overline{POE0}$ to $\overline{POE3}$ pin input signal detection and interrupts. The output level control/status register (OCSR) controls both the enable/disable of output comparison and interrupts.

Input Level Control/Status Register 1 (ICSR1): The input level control/status register (ICSR1) is a 16-bit readable/writable register that selects the $\overline{POE0}$ to $\overline{POE3}$ pin input modes, controls the enable/disable of interrupts, and indicates status.

| Bit | Bit Name | Initial value | R/W | Description |
|---------|----------|---------------|--------|---|
| 15 | POE3F | 0 | R/(W)* | <p>POE3 Flag</p> <p>This flag indicates that a high impedance request has been input to the $\overline{\text{POE3}}$ pin</p> <p>[Clearing condition]</p> <ul style="list-style-type: none"> By writing 0 to POE3F after reading a POE3F = 1 <p>[Setting condition]</p> <ul style="list-style-type: none"> When the input set by ICSR1 bits 7 and 6 occurs at the $\overline{\text{POE3}}$ pin |
| 14 | POE2F | 0 | R/(W)* | <p>POE2 Flag</p> <p>This flag indicates that a high impedance request has been input to the $\overline{\text{POE2}}$ pin</p> <p>[Clearing condition]</p> <ul style="list-style-type: none"> By writing 0 to POE2F after reading a POE2F = 1 <p>[Setting condition]</p> <ul style="list-style-type: none"> When the input set by ICSR1 bits 5 and 4 occurs at the $\overline{\text{POE2}}$ pin |
| 13 | POE1F | 0 | R/(W)* | <p>POE1 Flag</p> <p>This flag indicates that a high impedance request has been input to the $\overline{\text{POE1}}$ pin</p> <p>[Clearing condition]</p> <ul style="list-style-type: none"> By writing 0 to POE1F after reading a POE1F = 1 <p>[Setting condition]</p> <ul style="list-style-type: none"> When the input set by ICSR1 bits 3 and 2 occurs at the $\overline{\text{POE1}}$ pin |
| 12 | POE0F | 0 | R/(W)* | <p>POE0 Flag</p> <p>This flag indicates that a high impedance request has been input to the $\overline{\text{POE0}}$ pin</p> <p>[Clear condition]</p> <ul style="list-style-type: none"> By writing 0 to POE0F after reading a POE0F = 1 <p>[Set condition]</p> <ul style="list-style-type: none"> When the input set by ICSR1 bits 1 and 0 occurs at the $\overline{\text{POE0}}$ pin |
| 11 to 9 | — | All 0 | R | <p>Reserved</p> <p>These bits are always read as 0. The write value should always be 0.</p> |

| Bit | Bit Name | Initial value | R/W | Description |
|-----|----------|---------------|-----|---|
| 8 | PIE | 0 | R/W | <p>Port Interrupt Enable</p> <p>This bit enables/disables interrupt requests when any of the POE0F to POE3F bits of the ICSR1 are set to 1</p> <p>0: Interrupt requests disabled</p> <p>1: Interrupt requests enabled</p> |
| 7 | POE3M1 | 0 | R/W | POE3 mode 1, 0 |
| 6 | POE3M0 | 0 | R/W | <p>These bits select the input mode of the $\overline{\text{POE3}}$ pin</p> <p>00: Accept request on falling edge of $\overline{\text{POE3}}$ input</p> <p>01: Accept request when $\overline{\text{POE3}}$ input has been sampled for 16 Pϕ/8 clock pulses, and all are low level.</p> <p>10: Accept request when $\overline{\text{POE3}}$ input has been sampled for 16 Pϕ/16 clock pulses, and all are low level.</p> <p>11: Accept request when $\overline{\text{POE3}}$ input has been sampled for 16 Pϕ/128 clock pulses, and all are low level.</p> |
| 5 | POE2M1 | 0 | R/W | POE2 mode 1, 0 |
| 4 | POE2M0 | 0 | R/W | <p>These bits select the input mode of the $\overline{\text{POE2}}$ pin</p> <p>00: Accept request on falling edge of $\overline{\text{POE2}}$ input</p> <p>01: Accept request when $\overline{\text{POE2}}$ input has been sampled for 16 Pϕ/8 clock pulses, and all are low level.</p> <p>10: Accept request when $\overline{\text{POE2}}$ input has been sampled for 16 Pϕ/16 clock pulses, and all are low level.</p> <p>11: Accept request when $\overline{\text{POE2}}$ input has been sampled for 16 Pϕ/128 clock pulses, and all are low level.</p> |

| Bit | Bit Name | Initial value | R/W | Description |
|-----|----------|---------------|-----|--|
| 3 | POE1M1 | 0 | R/W | POE1 mode 1, 0 |
| 2 | POE1M0 | 0 | R/W | These bits select the input mode of the $\overline{\text{POE1}}$ pin 00: Accept request on falling edge of $\overline{\text{POE1}}$ input 01: Accept request when $\overline{\text{POE1}}$ input has been sampled for 16 $P\phi/8$ clock pulses, and all are low level. 10: Accept request when $\overline{\text{POE1}}$ input has been sampled for 16 $P\phi/16$ clock pulses, and all are low level. 11: Accept request when $\overline{\text{POE1}}$ input has been sampled for 16 $P\phi/128$ clock pulses, and all are low level. |
| 1 | POE0M1 | 0 | R/W | POE0 mode 1, 0 |
| 0 | POE0M0 | 0 | R/W | These bits select the input mode of the $\overline{\text{POE0}}$ pin 00: Accept request on falling edge of $\overline{\text{POE0}}$ input 01: Accept request when $\overline{\text{POE0}}$ input has been sampled for 16 $P\phi/8$ clock pulses, and all are low level. 10: Accept request when $\overline{\text{POE0}}$ input has been sampled for 16 $P\phi/16$ clock pulses, and all are low level. 11: Accept request when $\overline{\text{POE0}}$ input has been sampled for 16 $P\phi/128$ clock pulses, and all are low level. |

Note: * Only 0 can be written to clear the flag.

Output Level Control/Status Register (OCSR): The output level control/status register (OCSR) is a 16-bit readable/writable register that controls the enable/disable of both output level comparison and interrupts, and indicates status. If the OSF bit is set to 1, the high current pins become high impedance.

| Bit | Bit Name | Initial value | R/W | Description |
|----------|----------|---------------|--------|---|
| 15 | OSF | 0 | R/(W)* | <p>Output Short Flag</p> <p>This flag indicates that any one pair of the three pairs of 2 phase outputs compared have simultaneously become low level outputs.</p> <p>[Clearing condition]</p> <ul style="list-style-type: none"> By writing 0 to OSF after reading an OSF = 1 <p>[Setting condition]</p> <ul style="list-style-type: none"> When any one pair of the three 2-phase outputs simultaneously become low level |
| 14 to 10 | — | All 0 | R | <p>Reserved</p> <p>These bits are always read as 0. The write value should always be 0.</p> |
| 9 | OCE | 0 | R/W | <p>Output Level Compare Enable</p> <p>This bit enables the start of output level comparisons. When setting this bit to 1, pay attention to the output pin combinations shown in table 11.43, Mode Transition Combinations. When 0 is output, the OSF bit is set to 1 at the same time when this bit is set, and output goes to high impedance. Accordingly, bits 15 to 11 and bit 9 of the port E data register (PEDR) are set to 1. For the MTU output comparison, set the bit to 1 after setting the MTU's output pins with the PFC. Set this bit only when using pins as outputs.</p> <p>When the OCE bit is set to 1, if OIE = 0 a high-impedance request will not be issued even if OSF is set to 1. Therefore, in order to have a high-impedance request issued according to the result of the output level comparison, the OIE bit must be set to 1. When OCE = 1 and OIE = 1, an interrupt request will be generated at the same time as the high-impedance request: however, this interrupt can be masked by means of an interrupt controller (INTC) setting.</p> <p>0: Output level compare disabled</p> <p>1: Output level compare enabled; makes an output high impedance request when OSF = 1.</p> |

| Bit | Bit Name | Initial value | R/W | Description |
|--------|----------|---------------|-----|---|
| 8 | OIE | 0 | R/W | Output Short Interrupt Enable This bit makes interrupt requests when the OSF bit of the OCSR is set. 00: Interrupt requests disabled 01: Interrupt request enabled |
| 7 to 0 | — | All 0 | R | Reserved These bits are always read as 0. The write value should always be 0. |

Note: * Only 0 can be written to write the flag.

11.9.4 Operation

Input Level Detection Operation:

If the input conditions set by the ICSR1 occur on any of the $\overline{\text{POE}}$ pins, all high-current pins become high-impedance state. Note however, that these high-current pins become high-impedance state only when general input/output function or MTU function is selected in these pins.

1. Falling Edge Detection

When a change from high to low level is input to the $\overline{\text{POE}}$ pins.

2. Low-Level Detection

Figure 11.115 shows the low-level detection operation. Sixteen continuous low levels are sampled with the sampling clock established by the ICSR1. If even one high level is detected during this interval, the low level is not accepted.

Sampling starts when detecting the falling edge of the $\overline{\text{POE}}$ pin. Thereby, negate the $\overline{\text{POE}}$ pin when using $\overline{\text{POE}}$ function after sampling.

Furthermore, the timing when the large-current pins enter the high-impedance state from the sampling clock is the same in both falling-edge detection and in low-level detection.

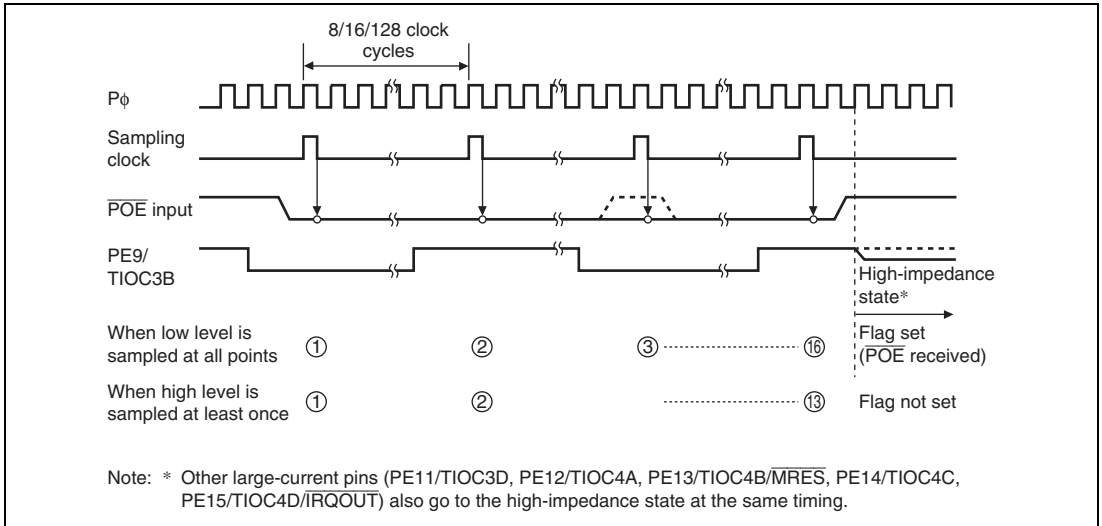

Figure 11.115 Low-Level Detection Operation

Output-Level Compare Operation:

Figure 11.116 shows an example of the output-level compare operation for the combination of PE9/TIOC3B and PE11/TIOC3D. The operation is the same for the other pin combinations.

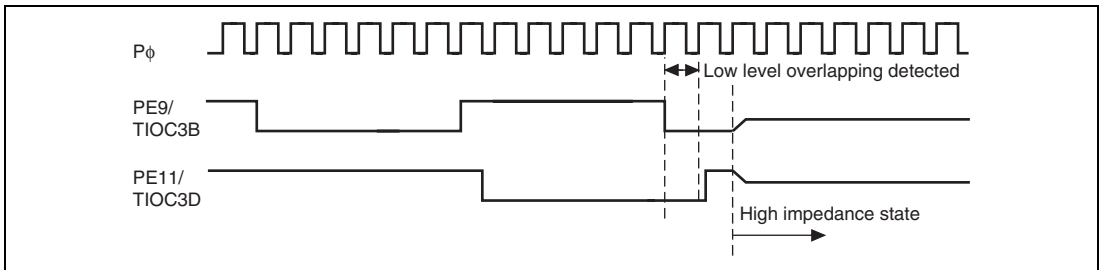

Figure 11.116 Output-Level Detection Operation

Release from High-Impedance State:

High-current pins that have entered high-impedance state due to input-level detection can be released either by returning them to their initial state with a power-on reset, or by clearing all of the bit 12 to 15 (POE0F to POE3F) flags of the ICSR1. High-current pins that have become high-impedance due to output-level detection can be released either by returning them to their initial state with a power-on reset, or by first clearing bit 9 (OCE) of the OCSR to disable output-level compares, then clearing the bit 15 (OSF) flag. However, when returning from high-impedance state by clearing the OSF flag, always do so only after outputting a high level from the high-current pins (TIOC3B, TIOC3D, TIOC4A, TIOC4B, TIOC4C, and TIOC4D). High-level outputs can be achieved by setting the MTU internal registers.

POE Timing:

Figure 11.117 shows an example of timing from $\overline{\text{POE}}$ input to high impedance of pin.

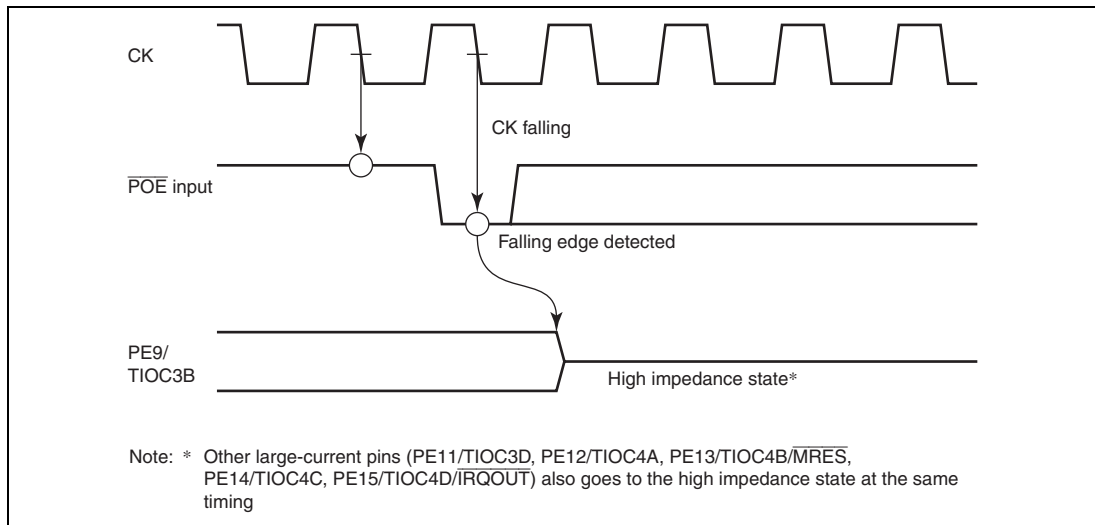

Figure 11.117 Falling Edge Detection Operation

11.9.5 Usage Notes

1. Make sure to set the input to the POE pin high, before detecting the level of the POE pin.
2. To clear the POE3F to POE0F bits in the input level control/status register 1 (ICSR1) and the OSF bit in the output level control/status register (OCSR) to 0, read ICSR1, ICSR2, and OCSR first. If there are bits which are read as 1, clear those bits to 0. Then write 1 to the other bits.

Section 12 Watchdog Timer

The watchdog timer (WDT) is an 8-bit timer that can reset this LSI internally if the counter overflows without rewriting the counter value due to a system crash or the like.

When this watchdog function is not needed, the WDT can be used as an interval timer. In interval timer operation, an interval timer interrupt is generated each time the counter overflows.

The block diagram of the WDT is shown in figure 12.1.

12.1 Features

- Switchable between watchdog timer mode and interval timer mode

In watchdog timer mode

- Output $\overline{\text{WDTOVF}}$ signal

If the counter overflows, it is possible to select whether this LSI is internally reset or not. A power-on reset or manual reset can be selected as an internal reset.

In interval timer mode

- If the counter overflows, the WDT generates an interval timer interrupt (ITI).
- Clears software standby mode
- Selectable from eight counter input clocks.

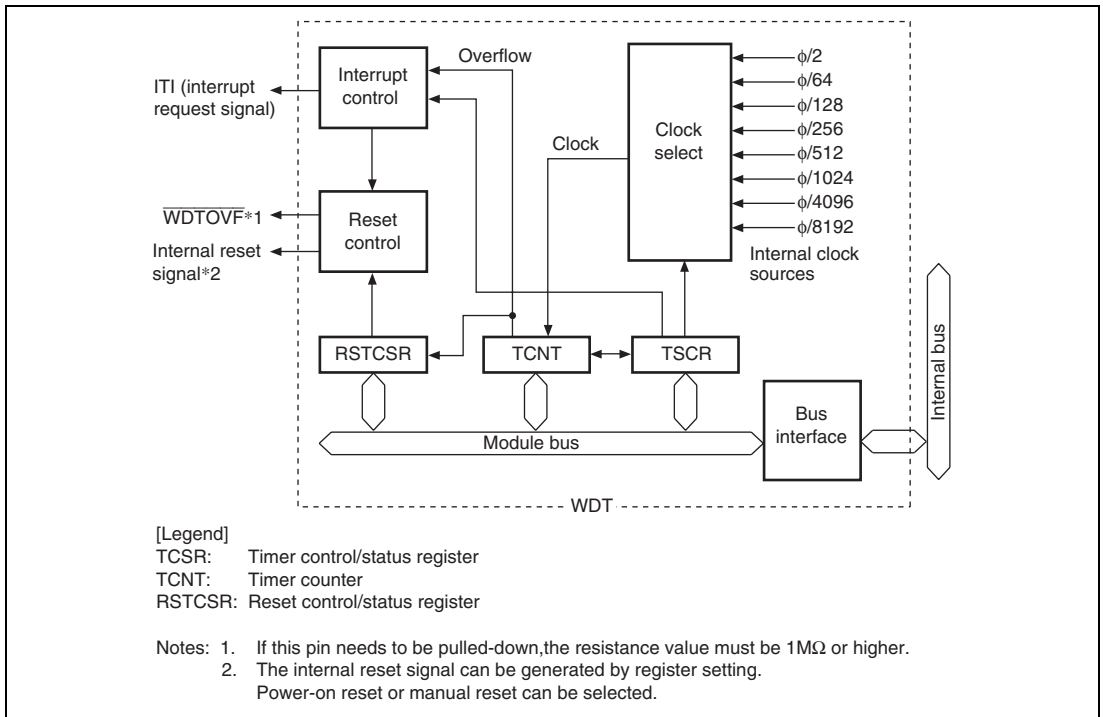

Figure 12.1 Block Diagram of WDT

12.2 Input/Output Pin

Table 12.1 shows the pin configuration.

Table 12.1 Pin Configuration

| Pin | Abbreviation | I/O | Function |
|-------------------------|----------------------------|--------|--|
| Watchdog timer overflow | $\overline{\text{WDTOVF}}$ | Output | Outputs the counter overflow signal in watchdog timer mode |

12.3 Register Descriptions

The WDT has the following three registers. For details, see section 25, List of Registers. To prevent accidental overwriting, TCSR, TCNT, and RSTCSR have to be written to in a method different from normal registers. For details, see section 12.6.1, Notes on Register Access.

- Timer control/status register (TCSR)
- Timer counter (TCNT)
- Reset control/status register (RSTCSR)

12.3.1 Timer Counter (TCNT)

TCNT is an 8-bit readable/writable upcounter. When the timer enable bit (TME) in the timer control/status register (TCSR) is set to 1, TCNT starts counting pulses of an internal clock selected by clock select bits 2 to 0 (CKS2 to CKS0) in TCSR. When the value of TCNT overflows (changes from H'FF to H'00), a watchdog timer overflow signal ($\overline{\text{WDTOVF}}$) or interval timer interrupt (ITI) is generated, depending on the mode selected in the $\overline{\text{WT/IT}}$ bit of TCSR.

The initial value of TCNT is H'00.

12.3.2 Timer Control/Status Register (TCSR)

TCSR is an 8-bit readable/writable register. Its functions include selecting the clock source to be input to TCNT, and the timer mode.

| Bit | Bit Name | Initial Value | R/W | Description |
|-----|----------------------------|---------------|---------------------|--|
| 7 | OVF | 0 | R/(W)* ¹ | <p>Overflow Flag</p> <p>Indicates that TCNT has overflowed in interval timer mode. Only a write of 0 is permitted, to clear the flag. This flag is not set in watchdog timer mode.</p> <p>[Setting condition]</p> <ul style="list-style-type: none"> When TCNT overflows in interval timer mode. <p>[Clearing condition]</p> <ul style="list-style-type: none"> When writing 0 to this bit after reading this bit or when writing 0 to the TME bit in interval timer mode. |
| 6 | WT/ $\overline{\text{IT}}$ | 0 | R/W | <p>Timer Mode Select</p> <p>Selects whether the WDT is used as a watchdog timer or interval timer. When TCNT overflows, the WDT either generates an interval timer interrupt (ITI) or generates a $\overline{\text{WDTOVF}}$ signal, depending on the mode selected.</p> <p>0: Interval timer mode Interval timer interrupt (ITI) request to the CPU when TCNT overflows</p> <p>1: Watchdog timer mode $\overline{\text{WDTOVF}}$ signal output externally when TCNT overflows. For details on the TCNT overflow in watchdog timer mode, see section 12.3.3, Reset Control/Status Register (RSTCSR).</p> |
| 5 | TME | 0 | R/W | <p>Timer Enable</p> <p>Enables or disables the timer.</p> <p>0: Timer disabled TCNT is initialized to H'00 and count-up stops</p> <p>1: Timer enabled TCNT starts counting. A $\overline{\text{WDTOVF}}$ signal or interrupt is generated when TCNT overflows.</p> |

| Bit | Bit Name | Initial Value | R/W | Description |
|------|----------|---------------|-----|--|
| 4, 3 | — | All 1 | R | Reserved These bits are always read as 1. The write value should always be 1. |
| 2 | CKS2 | 0 | R/W | Clock Select 2 to 0 |
| 1 | CKS1 | 0 | R/W | Select one of eight internal clock sources for input to TCNT. The clock signals are obtained by dividing the frequency of the system clock (ϕ). The overflow frequency for $\phi = 40$ MHz is enclosed in parentheses*2. 000: Clock $\phi/2$ (overflow interval: 12.8 μ s) 001: Clock $\phi/64$ (overflow interval: 409.6 μ s) 010: Clock $\phi/128$ (overflow interval: 0.8 ms) 011: Clock $\phi/256$ (overflow interval: 1.6 ms) 100: Clock $\phi/512$ (overflow interval: 3.3 ms) 101: Clock $\phi/1024$ (overflow interval: 6.6 ms) 110: Clock $\phi/4096$ (overflow interval: 26.2 ms) 111: Clock $\phi/8192$ (overflow interval: 52.4 ms) |
| 0 | CKS0 | 0 | R/W | |

- Notes:
1. Only a 0 can be written after reading 1.
 2. The overflow interval listed is the time from when the TCNT begins counting at H'00 until an overflow occurs.

12.3.3 Reset Control/Status Register (RSTCSR)

RSTCSR is an 8-bit readable/writable register that controls the generation of the internal reset signal when TCNT overflows, and selects the type of internal reset signal.

| Bit | Bit Name | Initial Value | R/W | Description |
|--------|----------|---------------|--------|---|
| 7 | WOVF | 0 | R/(W)* | <p>Watchdog Timer Overflow Flag</p> <p>This bit is set when TCNT overflows in watchdog timer mode. This bit cannot be set in interval timer mode.</p> <p>[Setting condition]</p> <ul style="list-style-type: none"> Set when TCNT overflows in watchdog timer mode <p>[Clearing condition]</p> <ul style="list-style-type: none"> Cleared by reading WOVF, and then writing 0 to WOVF |
| 6 | RSTE | 0 | R/W | <p>Reset Enable</p> <p>Specifies whether or not an internal reset signal is generated in the chip if TCNT overflows in watchdog timer mode.</p> <p>0: Internal reset signal is not generated even if TCNT overflows (Though this LSI is not reset, TCNT and TCSR in WDT are reset)</p> <p>1: Internal reset signal is generated if TCNT overflows</p> |
| 5 | RSTS | 0 | R/W | <p>Reset Select</p> <p>Selects the type of internal reset generated if TCNT overflows in watchdog timer mode.</p> <p>0: Power-on reset</p> <p>1: Manual reset</p> |
| 4 to 0 | — | All 1 | R | <p>Reserved</p> <p>These bits are always read as 1. The write value should always be 1.</p> |

Note: * Only 0 can be written for flag clearing.

12.4 Operation

12.4.1 Watchdog Timer Mode

To use the WDT as a watchdog timer, set the $\overline{WT/IT}$ and TME bits of TCSR to 1. Software must prevent TCNT overflow by rewriting the TCNT value (normally by writing H'00) before overflow occurs. No TCNT overflows will occur while the system is operating normally, but if TCNT fails to be rewritten and overflows occur due to a system crash or the like, a \overline{WDTOVF} signal is output externally. The \overline{WDTOVF} signal can be used to reset the system. The \overline{WDTOVF} signal is output for 128ϕ clock cycles.

If the RSTE bit in RSTCSR is set to 1, a signal to reset the chip will be generated internally simultaneous to the \overline{WDTOVF} signal when TCNT overflows. Either a power-on reset or a manual reset can be selected by the RSTS bit in RSTCSR. The internal reset signal is output for 512ϕ clock cycles.

When a WDT overflow reset is generated simultaneously with a reset input at the \overline{RES} pin, the \overline{RES} reset takes priority, and the WOVF bit in RSTCSR is cleared to 0.

The following are not initialized by a WDT reset signal:

- Port output enable (POE) registers of MTU
- Pin function controller (PFC) registers
- I/O port registers
- Reset control/status register (RSTCSR) of watchdog timer (WDT)

These registers are initialized only by an external power-on reset.

Besides, TCNT and TCSR of the WDT are not initialized by a manual reset from the \overline{MRES} pin, but are initialized by an internal manual reset generated by a WDT overflow.

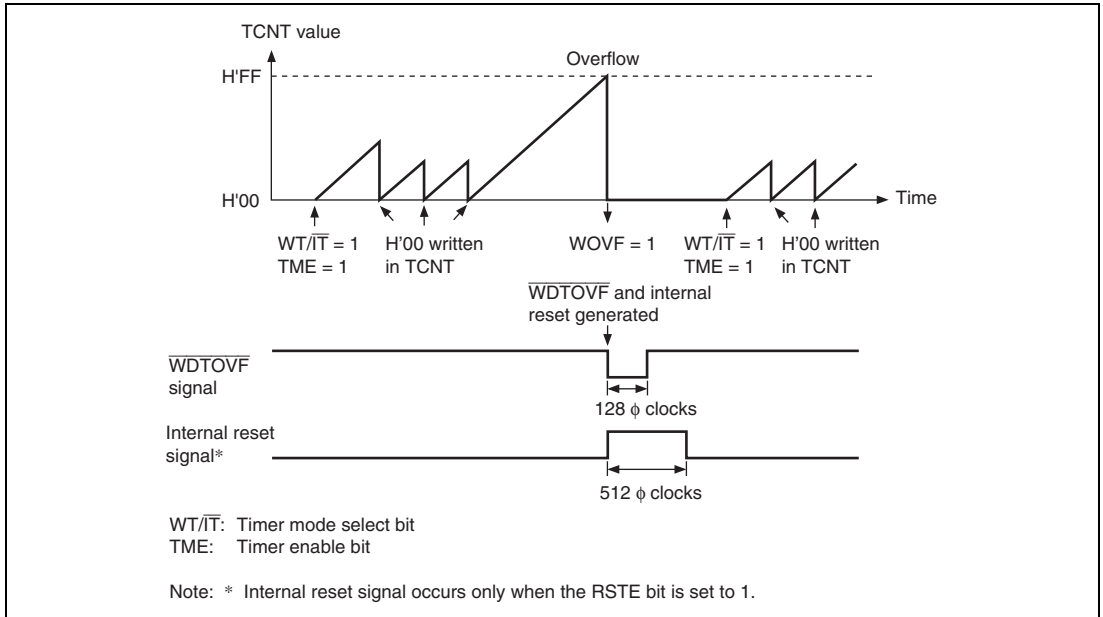

Figure 12.2 Operation in Watchdog Timer Mode

12.4.2 Interval Timer Mode

To use the WDT as an interval timer, clear WT/\overline{IT} to 0 and set TME to 1 in TCSR. An interval timer interrupt (ITI) is generated each time the timer counter (TCNT) overflows. This function can be used to generate interval timer interrupts at regular intervals.

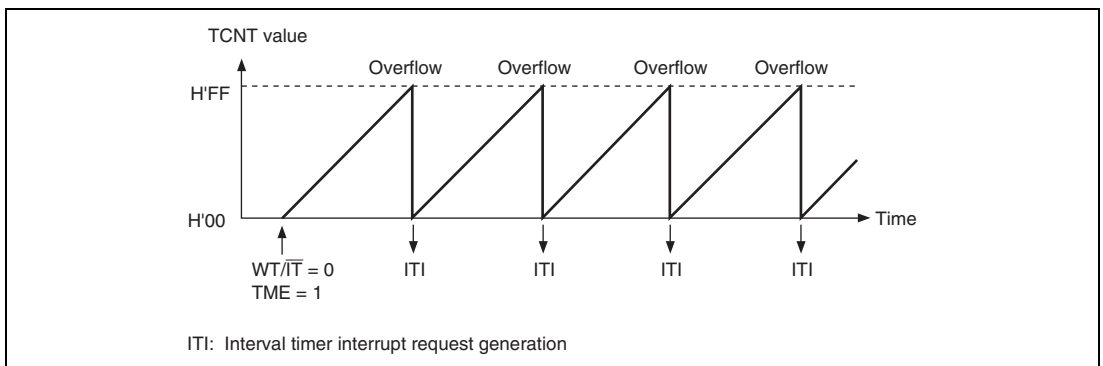

Figure 12.3 Operation in Interval Timer Mode

12.4.3 Clearing Software Standby Mode

The watchdog timer has a special function to clear software standby mode with an NMI interrupt or $\overline{\text{IRQ0}}$ to $\overline{\text{IRQ7}}$ interrupts. When using software standby mode, set the WDT as described below.

Before Transition to Software Standby Mode: The TME bit in TCSR must be cleared to 0 to stop the watchdog timer counter before entering software standby mode. The chip cannot enter software standby mode while the TME bit is set to 1. Set bits CKS2 to CKS0 in TCSR so that the counter overflow interval is equal to or longer than the oscillation settling time. See section 26.3, AC Characteristics, for the oscillation settling time.

Recovery from Software Standby Mode: When an NMI signal or $\overline{\text{IRQ0}}$ to $\overline{\text{IRQ7}}$ signals are received in software standby mode, the clock oscillator starts running and TCNT starts incrementing at the rate selected by bits CKS2 to CKS0 before software standby mode was entered. When TCNT overflows (changes from H'FF to H'00), the clock is presumed to be stable and usable; clock signals are supplied to the entire chip and software standby mode ends.

For details on software standby mode, see section 24, Power-Down Modes.

12.4.4 Timing of Setting Overflow Flag (OVF)

In interval timer mode, when TCNT overflows, the OVF bit of TCSR is set to 1 and an interval timer interrupt (ITI) is simultaneously requested. Figure 12.4 shows this timing.

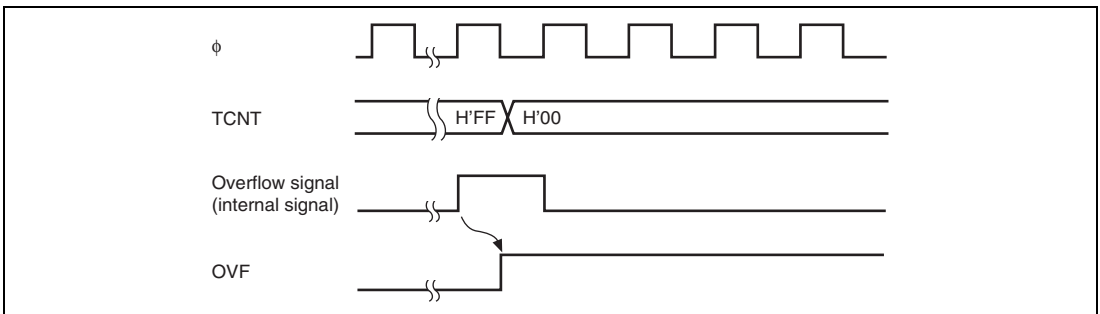

Figure 12.4 Timing of Setting OVF

12.4.5 Timing of Setting Watchdog Timer Overflow Flag (WOVF)

When TCNT overflows in watchdog timer mode, the WOVF bit of RSTCSR is set to 1 and a $\overline{\text{WDTOVF}}$ signal is output. When the RSTE bit in RSTCSR is set to 1, TCNT overflow enables an internal reset signal to be generated for the entire chip. Figure 12.5 shows this timing.

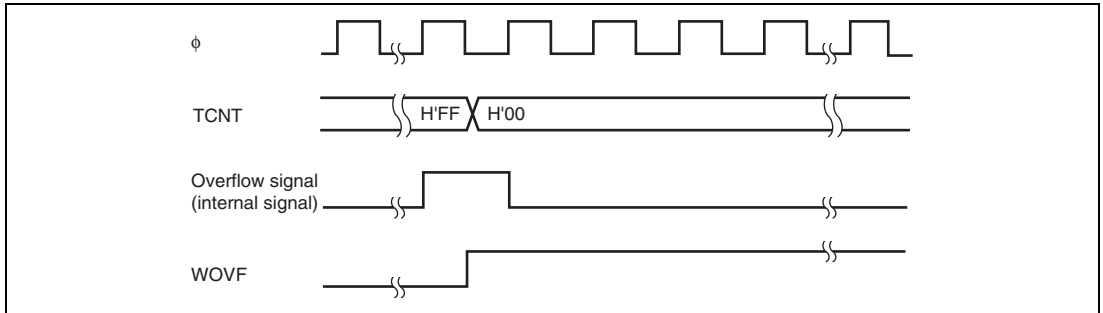

Figure 12.5 Timing of Setting WOVF

12.5 Interrupt Source

During interval timer mode operation, an overflow generates an interval timer interrupt (ITI). The interval timer interrupt is requested whenever the OVF flag is set to 1 in TCSR. OVF must be cleared to 0 in the interrupt handling routine.

Table 12.2 WDT Interrupt Source (in Interval Timer Mode)

| Name | Interrupt Source | Interrupt Flag | DMAC/DTC Activation |
|------|------------------|----------------|---------------------|
| ITI | TCNT overflow | OVF | Impossible |

12.6 Usage Notes

12.6.1 Notes on Register Access

The watchdog timer's TCNT, TCSR, and RSTCSR registers differ from other registers in being more difficult to write to. The procedures for writing to and reading these registers are given below.

Writing to TCNT and TCSR: These registers must be written by a word transfer instruction. They cannot be written by byte transfer instructions.

TCNT and TCSR both have the same write address. The write data must be contained in the lower byte of the written word. The upper byte must be H'5A (for TCNT) or H'A5 (for TCSR) (figure 12.6). This transfers the write data from the lower byte to TCNT or TCSR.

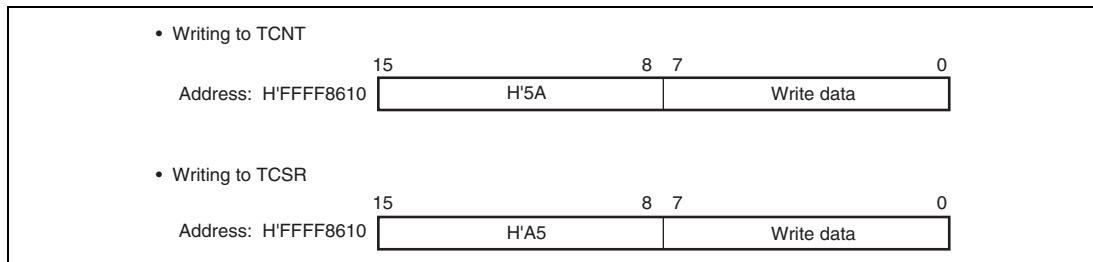

Figure 12.6 Writing to TCNT and TCSR

Writing to RSTCSR: RSTCSR must be written by a word access to address H'FFFF8612. It cannot be written by byte transfer instructions.

Procedures for writing 0 to WOVF (bit 7) and for writing to RSTE (bit 6) and RSTS (bit 5) are different, as shown in figure 12.7.

To write 0 to the WOVF bit, the write data must be H'A5 in the upper byte and H'00 in the lower byte. This clears the WOVF bit to 0. The RSTE and RSTS bits are not affected. To write to the RSTE and RSTS bits, the upper byte must be H'5A and the lower byte must be the write data. The values of bits 6 and 5 of the lower byte are transferred to the RSTE and RSTS bits, respectively. The WOVF bit is not affected.

- Writing 0 to the WOVF bit

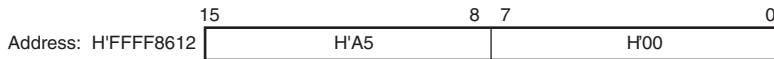

- Writing to the RSTE and RSTS bits



Figure 12.7 Writing to RSTCSR

Reading from TCNT, TCSR, and RSTCSR: TCNT, TCSR, and RSTCSR are read like other registers. Use byte transfer instructions. The read addresses are H'FFF8610 for TCSR, H'FFF8611 for TCNT, and H'FFF8613 for RSTCSR.

12.6.2 TCNT Write and Increment Contention

If a timer counter increment clock pulse is generated during the T3 state of a write cycle to TCNT, the write takes priority and the timer counter is not incremented. Figure 12.8 shows this operation.

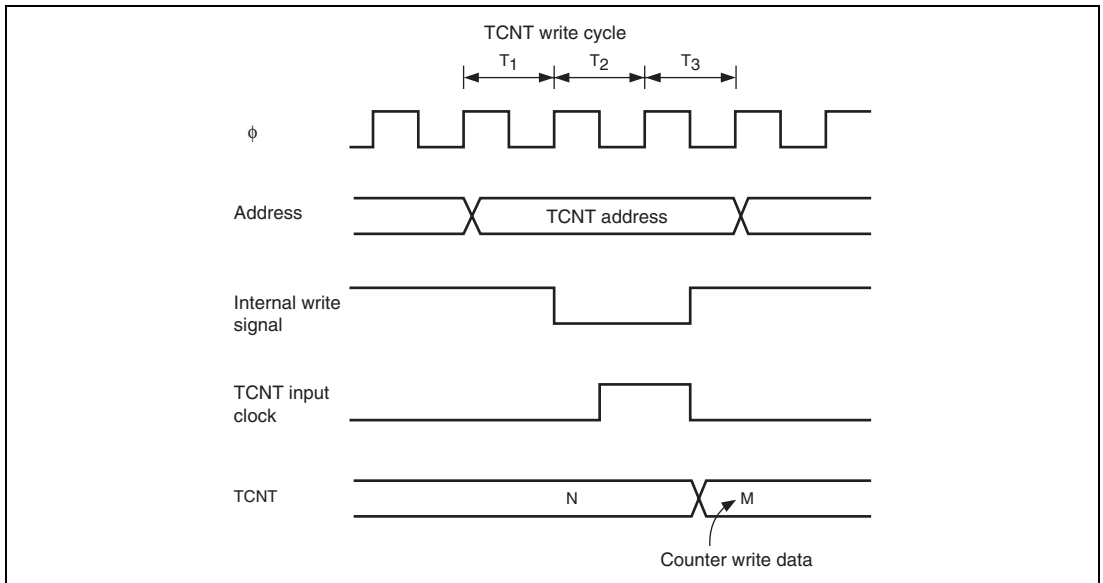

Figure 12.8 Contention between TCNT Write and Increment

12.6.3 Changing CKS2 to CKS0 Bit Values

If the values of bits CKS2 to CKS0 in the timer control/status register (TCSR) are rewritten while the WDT is running, the count may not increment correctly. Always stop the watchdog timer (by clearing the TME bit to 0) before changing the values of bits CKS2 to CKS0.

12.6.4 Changing between Watchdog Timer and Interval Timer Modes

To prevent incorrect operation, always stop the watchdog timer (by clearing the TME bit to 0) before switching between interval timer mode and watchdog timer mode.

12.6.5 System Reset by $\overline{\text{WDTOVF}}$ Signal

If a $\overline{\text{WDTOVF}}$ output signal is input to the $\overline{\text{RES}}$ pin, the chip cannot initialize correctly.

Avoid inputting the $\overline{\text{WDTOVF}}$ signal to the $\overline{\text{RES}}$ pin directly. To reset the entire system with the $\overline{\text{WDTOVF}}$ signal, use the circuit shown in figure 12.9.

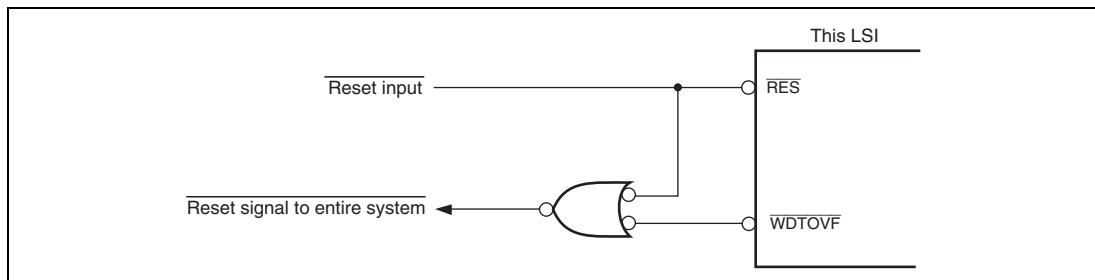

Figure 12.9 Example of System Reset Circuit Using $\overline{\text{WDTOVF}}$ Signal

12.6.6 Internal Reset in Watchdog Timer Mode

If the RSTE bit is cleared to 0 in watchdog timer mode, the chip will not be reset internally when a TCNT overflow occurs, but TCNT and TCSR in the WDT will be reset.

12.6.7 Manual Reset in Watchdog Timer Mode

When an internal reset is effected by TCNT overflow in watchdog timer mode, the processor waits until the end of the bus cycle at the time of manual reset generation before making the transition to manual reset exception processing. Therefore, the bus cycle is retained in a manual reset, but if a manual reset occurs while the bus is released, manual reset exception processing will be deferred until the CPU acquires the bus. However, if the interval from generation of the manual reset until the end of the bus cycle is equal to or longer than the internal manual reset interval of 512 cycles, the internal manual reset source is ignored instead of being deferred, and manual reset exception processing is not executed.

12.6.8 Note on Using $\overline{\text{WDTOVF}}$ Signal

Do not pull down the $\overline{\text{WDTOVF}}$ pin. If necessary, pull it down with resistance larger than 1 M Ω .

Section 13 Serial Communication Interface (SCI)

This LSI has four independent serial communication interface (SCI) channels. The SCI can handle both asynchronous and clocked synchronous serial communication. Serial data communication can be carried out with standard asynchronous communication chips such as a Universal Asynchronous Receiver/Transmitter (UART) or Asynchronous Communication Interface Adapter (ACIA). A function is also provided for serial communication between processors (multiprocessor communication function). The SCI also supports a smart card (IC card) interface conforming to ISO/IEC 7816-3 (Identification Card) as an extension function for asynchronous mode.

13.1 Features

- Choice of asynchronous or clocked synchronous serial communication mode
- Full-duplex communication capability

The transmitter and receiver are mutually independent, enabling transmission and reception to be executed simultaneously.

Double-buffering is used in both the transmitter and the receiver, enabling continuous transmission and continuous reception of serial data.
- On-chip baud rate generator allows any bit rate to be selected

External clock can be selected as a transfer clock source (except for a smart card interface).
- Choice of LSB-first or MSB-first transfer* (except in the case of asynchronous mode 7-bit data)
- Four interrupt sources

Four interrupt sources — transmit-end, transmit-data-empty, receive-data-full, and receive error — that can issue requests.

The transmit-data-empty interrupt and receive data full interrupts can activate the direct memory access controller (DMAC) and the data transfer controller (DTC).
- Module standby mode can be set

Asynchronous mode

- Data length: 7 or 8 bits
- Stop bit length: 1 or 2 bits
- Parity: Even, odd, or none
- Communication between multiprocessors
- Receive error detection: Parity, overrun, and framing errors
- Break detection: Break can be detected by reading the RxD pin level directly in case of a framing error

13. Serial Communication Interface (SCI)

Clocked synchronous mode

- Data length: 8 bits
- Receive error detection: Overrun errors detected

Smart card interface

- Data is automatically retransmitted if an error signal is received while data is being transmitted
- Direct convention and inverse convention both supported

Note: * The description in this section is based on LSB-first transfer.

Figure 13.1 shows a block diagram of the SCI.

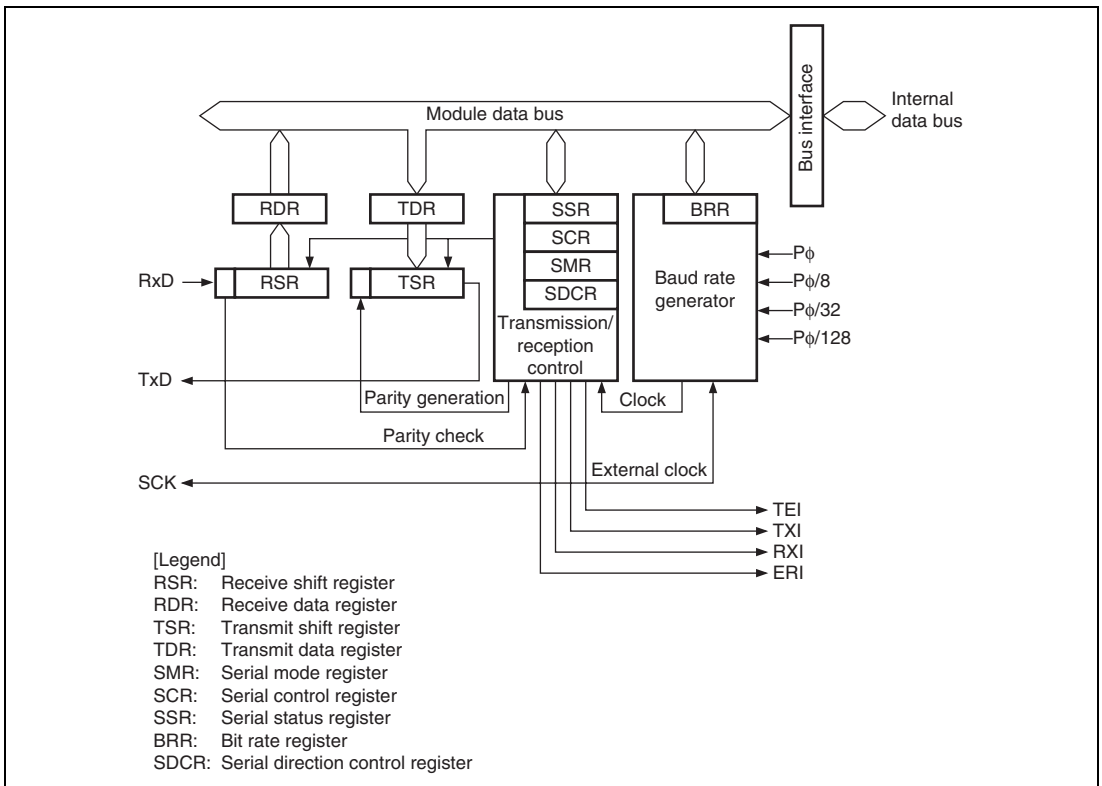

Figure 13.1 Block Diagram of SCI

13.2 Input/Output Pins

Table 13.1 shows the pins for each SCI channel.

Table 13.1 Pin Configuration

| Channel | Pin Name* | I/O | Function |
|---------|-----------|--------|---------------------------|
| 0 | SCK0 | I/O | SCI0 clock input/output |
| | RxD0 | Input | SCI0 receive data input |
| | TxD0 | Output | SCI0 transmit data output |
| 1 | SCK1 | I/O | SCI1 clock input/output |
| | RxD1 | Input | SCI1 receive data input |
| | TxD1 | Output | SCI1 transmit data output |
| 2 | SCK2 | I/O | SCI2 clock input/output |
| | RxD2 | Input | SCI2 receive data input |
| | TxD2 | Output | SCI2 transmit data output |
| 3 | SCK3 | I/O | SCI3 clock input/output |
| | RxD3 | Input | SCI3 receive data input |
| | TxD3 | Output | SCI3 transmit data output |

Note: * Pin names SCK, RxD, and TxD are used in the text for all channels, omitting the channel designation.

13.3 Register Descriptions

The SCI has the following registers for each channel. For details on register addresses and register states during each processing, refer to section 25, List of Registers. The serial mode register (SMR), serial control register (SCR), and serial status register (SSR) are described separately for normal serial communication interface mode and smart card interface mode because their bit functions differ in part.

Channel 0

- Serial mode register_0 (SMR_0)
- Bit rate register_0 (BRR_0)
- Serial control register_0 (SCR_0)
- Transmit data register_0 (TDR_0)
- Transmit shift register_0 (TSR_0)
- Serial status register_0 (SSR_0)
- Receive data register_0 (RDR_0)
- Receive shift register_0 (RSR_0)
- Serial direction control register_0 (SDCR_0)

Channel 1

- Serial mode register_1 (SMR_1)
- Bit rate register_1 (BRR_1)
- Serial control register_1 (SCR_1)
- Transmit data register_1 (TDR_1)
- Transmit shift register_1 (TSR_1)
- Serial status register_1 (SSR_1)
- Receive data register_1 (RDR_1)
- Receive shift register_1 (RSR_1)
- Serial direction control register_1 (SDCR_1)

Channel 2

- Serial mode register_2 (SMR_2)
- Bit rate register_2 (BRR_2)
- Serial control register_2 (SCR_2)
- Transmit data register_2 (TDR_2)
- Transmit shift register_2 (TSR_2)
- Serial status register_2 (SSR_2)
- Receive data register_2 (RDR_2)
- Receive shift register_2 (RSR_2)
- Serial direction control register_2 (SDCR_2)

Channel 3

- Serial mode register_3 (SMR_3)
- Bit rate register_3 (BRR_3)
- Serial control register_3 (SCR_3)
- Transmit data register_3 (TDR_3)
- Transmit shift register_3 (TSR_3)
- Serial status register_3 (SSR_3)
- Receive data register_3 (RDR_3)
- Receive shift register_3 (RSR_3)
- Serial direction control register_3 (SDCR_3)

13.3.1 Receive Shift Register (RSR)

RSR is a shift register used to receive serial data that is input to the RxD pin and convert it into parallel data. When one byte of data has been received, it is transferred to RDR automatically. RSR cannot be directly read or written to by the CPU.

13.3.2 Receive Data Register (RDR)

RDR is an 8-bit register that stores receive data. When the SCI has received one byte of serial data, it transfers the received serial data from RSR to RDR where it is stored. After this, RSR is receive-enabled. Since RSR and RDR function as a double buffer in this way, enables continuous receive operations to be performed. After confirming that the RDRF bit in SSR is set to 1, read RDR for only once. RDR cannot be written to by the CPU. The initial value of RDR is H'00.

13.3.3 Transmit Shift Register (TSR)

TSR is a shift register that transmits serial data. To perform serial data transmission, the SCI first transfers transmit data from TDR to TSR, then sends the data to the TxD pin. TSR cannot be directly accessed by the CPU.

13.3.4 Transmit Data Register (TDR)

TDR is an 8-bit register that stores transmit data. When the SCI detects that TSR is empty, it transfers the transmit data written in TDR to TSR and starts transmission. The double-buffered structures of TDR and TSR enables continuous serial transmission. If the next transmit data has already been written to TDR during serial transmission, the SCI transfers the written data to TSR to continue transmission. Although TDR can be read or written to by the CPU at all times, to achieve reliable serial transmission, write transmit data to TDR for only once after confirming that the TDRE bit in SSR is set to 1. The initial value of TDR is H'FF.

13.3.5 Serial Mode Register (SMR)

SMR is used to set the SCI's serial transfer format and select the baud rate generator clock source.

Some bit functions of SMR differ between normal serial communication interface mode and smart card interface mode.

- Normal serial communication interface mode (when SMIF in SDCR is 0)

| Bit | Bit Name | Initial Value | R/W | Description |
|-----|--------------|---------------|-----|---|
| 7 | C/ \bar{A} | 0 | R/W | Communication Mode 0: Asynchronous mode 1: Clocked synchronous mode |
| 6 | CHR | 0 | R/W | Character Length (enabled only in asynchronous mode) 0: Selects 8 bits as the data length. 1: Selects 7 bits as the data length. LSB-first is fixed and the MSB (bit 7) of TDR is not transmitted in transmission. In clocked synchronous mode, a fixed data length of 8 bits is used. |
| 5 | PE | 0 | R/W | Parity Enable (enabled only in asynchronous mode) When this bit is set to 1, the parity bit is added to transmit data before transmission, and the parity bit is checked in reception. For a multiprocessor format, parity bit addition and checking are not performed regardless of the PE bit setting. |

13. Serial Communication Interface (SCI)

| Bit | Bit Name | Initial Value | R/W | Description |
|-----|--------------|---------------|-----|---|
| 4 | O/ \bar{E} | 0 | R/W | <p>Parity Mode (enabled only when the PE bit is 1 in asynchronous mode)</p> <p>0: Selects even parity.</p> <p>When even parity is set, parity bit addition is performed in transmission so that the total number of 1 bits in the transmit character plus the parity bit is even. In reception, a check is performed to see if the total number of 1 bits in the receive character plus parity bit is even.</p> <p>1: Selects odd parity.</p> <p>When odd parity is set, parity bit addition is performed in transmission so that the total number of 1 bits in the transmit character plus the parity bit is odd. In reception, a check is performed to see if the total number of 1 bits in the receive character plus the parity bit is odd.</p> |
| 3 | STOP | 0 | R/W | <p>Stop Bit Length (enabled only in asynchronous mode)</p> <p>Selects the stop bit length in transmission.</p> <p>0: 1 stop bit</p> <p>1: 2 stop bits</p> <p>In reception, only the first stop bit is checked. If the second stop bit is 0, it is treated as the start bit of the next transmit character.</p> |
| 2 | MP | 0 | R/W | <p>Multiprocessor Mode (enabled only in asynchronous mode)</p> <p>When this bit is set to 1, the multiprocessor communication function is enabled. The PE bit and O/\bar{E} bit settings are invalid in multiprocessor mode.</p> |
| 1 | CKS1 | 0 | R/W | Clock Select 1 and 0 |
| 0 | CKS0 | 0 | R/W | <p>These bits select the clock source for the baud rate generator.</p> <p>00: Pϕ clock (n = 0)</p> <p>01: Pϕ/8 clock (n = 1)</p> <p>10: Pϕ/32 clock (n = 2)</p> <p>11: Pϕ/128 clock (n = 3)</p> <p>For the relation between the setting of CKS1 and CKS2 and the baud rate, see section 13.3.9, Bit Rate Register (BRR). n is the decimal display of the value of n in BRR (see section 13.3.9, Bit Rate Register (BRR)).</p> |

- Smart card interface mode (when SMIF in SDCR is 1)

| Bit | Bit Name | Initial Value | R/W | Description |
|-----|-------------|---------------|-----|---|
| 7 | GM | 0 | R/W | GSM Mode When this bit is set to 1, the SCI operates in GSM mode. In GSM mode, the timing of the TEND setting is advanced by 11.0 etu, and clock output control function is added. For details, refer to section 13.7.7, Clock Output Control. |
| 6 | BLK | 0 | R/W | When this bit is set to 1, the SCI operates in block transfer mode. For details on block transfer mode, refer to section 13.7.3, Block Transfer Mode. During reception in smart card interface mode, this bit must be set to 1. |
| 5 | PE | 0 | R/W | Parity Enable (enabled only in asynchronous mode) When this bit is set to 1, the parity bit is added to transmit data in transmission, and the parity bit is checked in reception. In smart card interface mode, this bit must be set to 1. |
| 4 | O \bar{E} | 0 | R/W | Parity Mode (enabled only when the PE bit is 1 in asynchronous mode) 0: Selects even parity. 1: Selects odd parity. For details on setting this bit in smart card interface mode, refer to section 13.7.2, Data Format (Except for Block Transfer Mode). |
| 3 | BCP1 | 0 | R/W | Basic Clock Pulse 1 and 0 |
| 2 | BCP0 | 0 | R/W | These bits select the number of basic clock cycles in a 1-bit transfer interval in smart card interface mode. 00: 32 clocks (S = 32) 01: 64 clocks (S = 64) 10: 372 clocks (S = 372) 11: 256 clocks (S = 256) For details, refer to section 13.7.4, Receive Data Sampling Timing and Reception Margin. S stands for the value of S in BRR (see section 13.3.9, Bit Rate Register (BRR)). |

13. Serial Communication Interface (SCI)

| Bit | Bit Name | Initial Value | R/W | Description |
|-----|----------|---------------|-----|---|
| 1 | CKS1 | 0 | R/W | Clock Select 1 and 0 |
| 0 | CKS0 | 0 | R/W | These bits select the clock source for the on-chip baud rate generator. 00: P ϕ clock (n = 0) 01: P ϕ /8 clock (n = 1) 10: P ϕ /32 clock (n = 2) 11: P ϕ /128 clock (n = 3) For details on the relationship between the setting of these bits and the baud rate, refer to section 13.3.9, Bit Rate Register (BRR). n is the decimal representation of the value of n in BRR (see section 13.3.9, Bit Rate Register (BRR)). |

Note: etu (Elementary Time Unit): Abbreviation for the transfer period for one bit.

13.3.6 Serial Control Register (SCR)

SCR is a register that performs enabling or disabling of SCI transfer operations and interrupt requests, and selection of the transfer clock source. For details on interrupt requests, refer to section 13.8, Interrupt Sources. Some bit functions of SCR differ between normal serial communication interface mode and smart card interface mode.

- Normal serial communication interface mode (when SMIF in SDCR is 0)

| Bit | Bit Name | Initial Value | R/W | Description |
|-----|----------|---------------|-----|---|
| 7 | TIE | 0 | R/W | Transmit Interrupt Enable When this bit is set to 1, a TXI interrupt request is enabled. TXI interrupt request cancellation can be performed by reading 1 from the TDRE flag in SSR, then clearing it to 0, or clearing the TIE bit to 0. |
| 6 | RIE | 0 | R/W | Receive Interrupt Enable When this bit is set to 1, RXI and ERI interrupt requests are enabled. RXI and ERI interrupt request cancellation can be performed by reading 1 from the RDRF, FER, PER, or ORER flag in SSR, then clearing the flag to 0, or clearing the RIE bit to 0. |

| Bit | Bit Name | Initial Value | R/W | Description |
|-----|----------|---------------|-----|--|
| 5 | TE | 0 | R/W | <p>Transmit Enable</p> <p>When this bit is set to 1, transmission is enabled.</p> <p>In this state, serial transmission is started when transmit data is written to TDR and the TDRE flag in SSR is cleared to 0.</p> <p>SMR setting must be made to decide the transfer format before setting the TE bit to 1. When this bit is cleared to 0, transmit operation is disabled, and the TDRE flag in SSR is fixed to 1.</p> |
| 4 | RE | 0 | R/W | <p>Receive Enable</p> <p>When this bit is set to 1, reception is enabled.</p> <p>Serial reception is started in this state when a start bit is detected in asynchronous mode or synchronous clock input is detected in clocked synchronous mode.</p> <p>SMR setting must be made to decide the receive format before setting the RE bit to 1.</p> <p>Clearing the RE bit to 0 disables reception and does not affect the RDRF, FER, PER, and ORER flags, which retain their states.</p> |
| 3 | MPIE | 0 | R/W | <p>Multiprocessor Interrupt Enable (enabled only when the MP bit in SMR is 1 in asynchronous mode)</p> <p>When this bit is set to 1, receive data in which the multiprocessor bit is 0 is skipped, and setting of the RDRF, FER, and ORER status flags in SSR is prohibited. On receiving data in which the multiprocessor bit is 1, this bit is automatically cleared and normal reception is resumed. For details, refer to section 13.5, Multiprocessor Communication Function.</p> <p>When receive data including MPB = 0 is received, receive data transfer from RSR to RDR, receive error detection, and setting of the RDRF, FER, and ORER flags in SSR, are not performed.</p> <p>When receive data including MPB = 1 is received, the MPB bit in SSR is set to 1, the MPIE bit is cleared to 0 automatically, and generation of RXI and ERI interrupts (when the TIE and RIE bits in SCR are set to 1) and FER and ORER flag setting are enabled.</p> |

| Bit | Bit Name | Initial Value | R/W | Description |
|-----|----------|---------------|-----|---|
| 2 | TEIE | 0 | R/W | <p>Transmit End Interrupt Enable</p> <p>When this bit is set to 1, a TEI interrupt request is enabled.</p> <p>TEI cancellation can be performed by reading 1 from the TDRE flag in SSR, then clearing it to 0 and clearing the TEND flag to 0, or clearing the TEIE bit to 0.</p> |
| 1 | CKE1 | 0 | R/W | Clock Enable 1 and 0 |
| 0 | CKE0 | 0 | R/W | <p>Select the clock source and SCK pin function.</p> <p>Asynchronous mode:</p> <p>00: Internal clock, SCK pin used for input pin (input signal is ignored) or output pin (output level is undefined)</p> <p>01: Internal clock, SCK pin used for clock output (The output clock frequency is the same as the bit rate)</p> <p>10: External clock, SCK pin used for clock input (The input clock frequency is 16 times the bit rate)</p> <p>11: External clock, SCK pin used for clock input (The input clock frequency is 16 times the bit rate)</p> <p>Clocked synchronous mode:</p> <p>00: Internal clock, SCK pin used for synchronous clock output</p> <p>01: Internal clock, SCK pin used for synchronous clock output</p> <p>10: External clock, SCK pin used for synchronous clock input</p> <p>11: External clock, SCK pin used for synchronous clock input</p> |

- Smart card interface mode (when SMIF in SDCR is 1)

| Bit | Bit Name | Initial Value | R/W | Description |
|-----|----------|---------------|-----|---|
| 7 | TIE | 0 | R/W | <p>Transmit Interrupt Enable</p> <p>When this bit is set to 1, a TXI interrupt request is enabled.</p> <p>TXI interrupt request cancellation can be performed by reading 1 from the TDRE flag in SSR, then clearing it to 0, or clearing the TIE bit to 0.</p> |
| 6 | RIE | 0 | R/W | <p>Receive Interrupt Enable</p> <p>When this bit is set to 1, RXI and ERI interrupt requests are enabled.</p> <p>RXI and ERI interrupt request cancellation can be performed by reading 1 from the RDRF, FER, PER, or ORER flag in SSR, then clearing the flag to 0, or clearing the RIE bit to 0.</p> |
| 5 | TE | 0 | R/W | <p>Transmit Enable</p> <p>When this bit is set to 1, transmission is enabled.</p> <p>In this state, serial transmission is started when transmit data is written to TDR and the TDRE flag in SSR is cleared to 0.</p> <p>SMR setting must be made to decide the transfer format before setting the TE bit to 1. When this bit is cleared to 0, transmit operation is disabled, and the TDRE flag in SSR is fixed to 1.</p> |
| 4 | RE | 0 | R/W | <p>Receive Enable</p> <p>When this bit is set to 1, reception is enabled.</p> <p>Serial reception is started in this state when a start bit is detected in asynchronous mode or synchronous clock input is detected in clocked synchronous mode.</p> <p>SMR setting must be made to decide the receive format before setting the RE bit to 1.</p> <p>Clearing the RE bit to 0 disables reception and does not affect the RDRF, FER, PER, and ORER flags, which retain their states.</p> |

13. Serial Communication Interface (SCI)

| Bit | Bit Name | Initial Value | R/W | Description |
|-----|----------|---------------|-----|---|
| 3 | MPIE | 0 | R/W | <p>Multiprocessor Interrupt Enable (enabled only when the MP bit in SMR is 1 in asynchronous mode)</p> <p>Write 0 to this bit in smart card interface mode.</p> <p>When receive data including MPB = 0 is received, receive data transfer from RSR to RDR, receive error detection, and setting of the RDRF, FER, and ORER flags in SSR, are not performed.</p> <p>When receive data including MPB = 1 is received, the MPB bit in SSR is set to 1, the MPIE bit is cleared to 0 automatically, and generation of RXI and ERI interrupts (when the TIE and RIE bits in SCR are set to 1) and FER and ORER flag setting are enabled.</p> |
| 2 | TEIE | 0 | R/W | <p>Transmit End Interrupt Enable</p> <p>Write 0 to this bit in smart card interface mode.</p> <p>TEI cancellation can be performed by reading 1 from the TDRE flag in SSR, then clearing it to 0 and clearing the TEND flag to 0, or clearing the TEIE bit to 0.</p> |
| 1 | CKE1 | 0 | R/W | <p>Clock Enable 1 and 0</p> |
| 0 | CKE0 | 0 | R/W | <p>Enable or disable clock output from the SCK pin. The clock output can be dynamically switched in GSM mode. For details, refer to section 13.7.7, Clock Output Control.</p> <p>When the GM bit in SMR is 0:</p> <p>00: Output disabled (SCK pin functions as an input pin (ignored) or as an output pin (level is undefined))</p> <p>01: Clock output</p> <p>1X: Reserved</p> <p>When the GM bit in SMR is 1:</p> <p>00: Output fixed low</p> <p>01: Clock output</p> <p>10: Output fixed high</p> <p>11: Clock output</p> |

[Legend]

X: Don't care

13.3.7 Serial Status Register (SSR)

SSR is a register containing status flags of the SCI and multiprocessor bits for transfer. 1 cannot be written to flags TDRE, RDRF, ORER, PER, and FER; they can only be cleared.

Some bit functions of SSR differ between normal serial communication interface mode and smart card interface mode.

- Normal serial communication interface mode (when SMIF in SDCR is 0)

| Bit | Bit Name | Initial Value | R/W | Description |
|-----|----------|---------------|--------|---|
| 7 | TDRE | 1 | R/(W)* | <p>Transmit Data Register Empty</p> <p>Indicates whether TDR contains transmit data.</p> <p>[Setting conditions]</p> <ul style="list-style-type: none"> • Power-on reset or software standby mode • When the TE bit in SCR is 0 • When data is transferred from TDR to TSR and data can be written to TDR <p>[Clearing conditions]</p> <ul style="list-style-type: none"> • When 0 is written to TDRE after reading TDRE = 1 • When the DMAC is activated by a TXI interrupt request. • When the DTC is activated by a TXI interrupt request and transferred data to TDR while the DISEL bit in DTMR of DTC is 0. |

| Bit | Bit Name | Initial Value | R/W | Description |
|-----|----------|---------------|--------|---|
| 6 | RDRF | 0 | R/(W)* | <p>Receive Data Register Full</p> <p>Indicates that the received data is stored in RDR.</p> <p>[Setting condition]</p> <ul style="list-style-type: none">• When serial reception ends normally and receive data is transferred from RSR to RDR <p>[Clearing conditions]</p> <ul style="list-style-type: none">• Power-on reset or software standby mode• When 0 is written to RDRF after reading RDRF = 1• When the DMAC is activated by a RXI interrupt request.• When the DTC is activated by an RXI interrupt and transferred data from RDR while the DISEL bit in DTMR of DTC is 0. <p>RDR and the RDRF flag are not affected and retain their previous states even if the RE bit in SCR is cleared to 0. If reception of the next data is completed while the RDRF flag is still set to 1, an overrun error will occur and the receive data will be lost.</p> |
| 5 | ORER | 0 | R/(W)* | <p>Overrun Error</p> <p>Indicates that an overrun error occurred during reception, causing abnormal termination.</p> <p>[Setting condition]</p> <ul style="list-style-type: none">• When the next serial reception is completed while RDRF = 1 <p>The receive data prior to the overrun error is retained in RDR, and the data received subsequently is lost. Also, subsequent serial reception cannot be continued while the ORER flag is set to 1. In clocked synchronous mode, serial transmission cannot be continued either.</p> <p>[Clearing conditions]</p> <ul style="list-style-type: none">• Power-on reset or software standby mode• When 0 is written to ORER after reading ORER = 1 <p>The ORER flag is not affected and retains its previous value when the RE bit in SCR is cleared to 0.</p> |

| Bit | Bit Name | Initial Value | R/W | Description |
|-----|----------|---------------|--------|---|
| 4 | FER | 0 | R/(W)* | <p>Framing Error</p> <p>Indicates that a framing error occurred during reception in asynchronous mode, causing abnormal termination.</p> <p>[Setting condition]</p> <ul style="list-style-type: none"> When the stop bit is 0 <p>In 2 stop bit mode, only the first stop bit is checked for a value to 1; the second stop bit is not checked. If a framing error occurs, the receive data is transferred to RDR but the RDRF flag is not set. Also, subsequent serial reception cannot be continued while the FER flag is set to 1. In clocked synchronous mode, serial transmission cannot be continued, either.</p> <p>[Clearing conditions]</p> <ul style="list-style-type: none"> Power-on reset or software standby mode When 0 is written to FER after reading FER = 1 <p>The FER flag is not affected and retains its previous value when the RE bit in SCR is cleared to 0.</p> |
| 3 | PER | 0 | R/(W)* | <p>Parity Error</p> <p>Indicates that a parity error occurred during reception using parity addition in asynchronous mode, causing abnormal termination.</p> <p>[Setting condition]</p> <ul style="list-style-type: none"> When a parity error is detected during reception <p>If a parity error occurs, the receive data is transferred to RDR but the RDRF flag is not set. Also, subsequent serial reception cannot be continued while the PER flag is set to 1. In clocked synchronous mode, serial transmission cannot be continued, either.</p> <p>[Clearing conditions]</p> <ul style="list-style-type: none"> Power-on reset or software standby mode When 0 is written to PER after reading PER = 1 <p>The PER flag is not affected and retains its previous value when the RE bit in SCR is cleared to 0.</p> |

13. Serial Communication Interface (SCI)

| Bit | Bit Name | Initial Value | R/W | Description |
|-----|----------|---------------|-----|---|
| 2 | TEND | 1 | R | <p>Transmit End</p> <p>Indicates that transmission has been ended.</p> <p>[Setting conditions]</p> <ul style="list-style-type: none">• Power-on reset or software standby mode• When the TE bit in SCR is 0• When TDRE = 1 at transmission of the last bit of a 1-byte serial transmit character <p>[Clearing conditions]</p> <ul style="list-style-type: none">• When 0 is written to TDRE after reading TDRE = 1• When the DMAC is activated by a TXI interrupt request.• When the DTC is activated by a TXI interrupt and transmit data is written to TDR while the DISEL bit in DTMR of DTC is 0. |
| 1 | MPB | 0 | R | <p>Multiprocessor Bit</p> <p>Stores the multiprocessor bit in the receive data. When the RE bit in SCR is cleared to 0, its previous state is retained.</p> |
| 0 | MPBT | 0 | R/W | <p>Multiprocessor Bit Transfer</p> <p>Sets the multiprocessor bit value to be added to the transmit data.</p> |

Note: * Only 0 can be written to clear the flag.

- Smart card interface mode (when SMIF in SDCR is 1)

| Bit | Bit Name | Initial Value | R/W | Description |
|-----|----------|---------------|--------|---|
| 7 | TDRE | 1 | R/(W)* | <p>Transmit Data Register Empty</p> <p>Indicates whether TDR contains transmit data.</p> <p>[Setting conditions]</p> <ul style="list-style-type: none"> • Power-on reset or software standby mode • When the TE bit in SCR is 0 • When data is transferred from TDR to TSR <p>[Clearing conditions]</p> <ul style="list-style-type: none"> • When 0 is written to TDRE after reading TDRE = 1 • When the DMAC is activated by a TXI interrupt • When the DTC is activated by a TXI interrupt and transmit data is transferred to TDR while the DISEL bit in DTMR of the DTC is 0 |
| 6 | RDRF | 0 | R/(W)* | <p>Receive Data Register Full</p> <p>Indicates that the receive data is stored in RDR.</p> <p>[Setting condition]</p> <ul style="list-style-type: none"> • When serial reception ends normally and receive data is transferred from RSR to RDR <p>[Clearing conditions]</p> <ul style="list-style-type: none"> • Power-on reset or software standby mode • When 0 is written to RDRF after reading RDRF = 1 • When the DMAC is activated by an RXI interrupt • When the DTC is activated by an RXI interrupt and data is transferred from RDR while the DISEL bit in DTMR of the DTC is 0 <p>The RDRF flag is not affected and retains its previous value even if the RE bit in SCR is cleared to 0.</p> <p>If reception of the next data is completed while the RDRF flag is still set to 1, an overrun error will occur and the receive data will be lost.</p> |

| Bit | Bit Name | Initial Value | R/W | Description |
|-----|----------|---------------|--------|---|
| 5 | ORER | 0 | R/(W)* | <p>Overrun Error</p> <p>Indicates that an overrun error occurred during reception, causing abnormal termination.</p> <p>[Setting condition]</p> <ul style="list-style-type: none">When the next serial reception is completed while RDRF = 1 <p>The receive data prior to the overrun error is retained in RDR, and the data received subsequently is lost. Also, subsequent serial reception cannot be continued while the ORER flag is set to 1. In clocked synchronous mode, serial transmission cannot be continued, either.</p> <p>[Clearing conditions]</p> <ul style="list-style-type: none">Power-on reset or software standby modeWhen 0 is written to ORER after reading ORER = 1 <p>The ORER flag is not affected and retains its previous state even if the RE bit in SCR is cleared to 0.</p> |
| 4 | ERS | 0 | R/(W)* | <p>Error Signal Status</p> <p>Indicates that the status of an error signal returned from the receive side at transmission.</p> <p>[Setting condition]</p> <ul style="list-style-type: none">When the low level of the error signal is sampled <p>[Clearing conditions]</p> <ul style="list-style-type: none">Power-on reset or software standby modeWhen 0 is written to ERS after reading ERS = 1 <p>The ERS flag is not affected and retains its previous state even if the TE bit in SCR is cleared to 0.</p> |

| Bit | Bit Name | Initial Value | R/W | Description |
|-----|----------|---------------|--------|---|
| 3 | PER | 0 | R/(W)* | <p>Parity Error</p> <p>Indicates that a parity error occurred during reception using parity addition in asynchronous mode, causing abnormal termination.</p> <p>[Setting condition]</p> <ul style="list-style-type: none"> When a parity error is detected during reception <p>If a parity error occurs, the receive data is transferred to RDR but the RDRF flag is not set. Also, subsequent serial reception cannot be continued while the PER flag is set to 1. In clocked synchronous mode, serial transmission cannot be continued, either.</p> <p>[Clearing conditions]</p> <ul style="list-style-type: none"> Power-on reset or software standby mode When 0 is written to PER after reading PER = 1 <p>The PER flag is not affected and retains its previous state even if the RE bit in SCR is cleared to 0.</p> |

| Bit | Bit Name | Initial Value | R/W | Description |
|-----|----------|---------------|-----|--|
| 2 | TEND | 1 | R | <p>Transmit End</p> <p>This bit is set to 1 when no error signal has been sent back from the receive side and the next transmit data is ready to be transferred to TDR.</p> <p>[Setting conditions]</p> <ul style="list-style-type: none"> • Power-on reset or software standby mode • When the TE bit in SCR is 0 and the ESR bit is also 0 • When the ESR bit is 0 and the TDRE bit is 1 after the specified interval following transmission of 1-byte data <p>The timing of bit setting differs according to the register setting as follows:</p> <p>When GM = 0 and BLK = 0, 2.5 etu after transmission starts</p> <p>When GM = 0 and BLK = 1, 1.0 etu after transmission starts</p> <p>When GM = 1 and BLK = 0, 1.5 etu after transmission starts</p> <p>When GM = 1 and BLK = 1, 1.0 etu after transmission starts</p> <p>[Clearing conditions]</p> <ul style="list-style-type: none"> • When 0 is written to TDRE after reading TDRE = 1 • When the DMAC is activated by a TXI interrupt • When the DTC is activated by a TXI interrupt and transmit data is transferred to TDR while the DISEL bit in DTMR of the DTC is 0 |
| 1 | MPB | 0 | R | <p>Multiprocessor</p> <p>This bit is not used in smart card interface mode.</p> |
| 0 | MPBT | 0 | R/W | <p>Multiprocessor Bit Transfer</p> <p>Write 0 to this bit in smart card interface mode.</p> |

Note: * Only 0 can be written to clear the flag.

13.3.8 Serial Direction Control Register (SDCR)

SDCR selects LSB-first or MSB-first transfer and sets the smart card interface. With an 8-bit data length, LSB-first/MSB-first selection is available regardless of the communication mode. With a 7-bit data length, LSB-first transfer must be selected. The description in this section assumes LSB-first transfer.

| Bit | Bit Name | Initial Value | R/W | Description |
|--------|----------|---------------|-----|--|
| 7 to 4 | — | All 1 | R | Reserved The write value should always be 1. Operation cannot be guaranteed if 0 is written. |
| 3 | DIR | 0 | R/W | Data Transfer Direction Selects the serial/parallel conversion direction. 0: Transfer in LSB-first 1: Transfer in MSB-first The bit setting is valid only when the transfer data format is 8 bits. For 7-bit data, LSB-first is fixed. |
| 2 | SINV | 0 | R/W | Smart Card Data Invert Specifies inversion of the data logic level. The SINV bit does not affect the logic level of the parity bit. To invert the parity bit, invert the O/ \bar{E} bit in SMR. This bit is valid only in smart card interface mode. In normal asynchronous mode or clocked synchronous mode, clear this bit to 0. 0: TDR contents are transmitted as they are. Receive data is stored as it is in RDR 1: TDR contents are inverted before being transmitted. Receive data is stored in inverted form in RDR |
| 1 | — | 1 | R | Reserved This bit is always read as 1 and cannot be modified. |
| 0 | SMIF | 0 | R/W | Smart Card Interface Mode Select This bit is set to 1 to make the SCI operate in smart card interface mode. 0: Normal asynchronous mode or clocked synchronous mode 1: Smart card interface mode |

13.3.9 Bit Rate Register (BRR)

BRR is an 8-bit register that adjusts the bit rate. As the SCI performs baud rate generator control independently for each channel, different bit rates can be set for each channel. Table 13.2 shows the relationships between the N setting in BRR and the effective bit rate B_0 for asynchronous, clocked synchronous, and smart card interface modes. The initial value of BRR is H'FF, and it can be read from or written to by the CPU at all times.

Table 13.2 Relationships between N Setting in BRR and Effective Bit Rate B_0

| Mode | Bit Rate | Error |
|---|---|---|
| Asynchronous mode (n = 0) | $B_0 = \frac{P\phi \times 10^6}{32 \times 2^{2n} \times (N + 1)}$ | $\text{Error (\%)} = \left(\frac{B_0}{B_1} - 1 \right) \times 100$ |
| Asynchronous mode (n = 1 to 3) | $B_0 = \frac{P\phi \times 10^6}{32 \times 2^{2n+1} \times (N + 1)}$ | $\text{Error (\%)} = \left(\frac{B_0}{B_1} - 1 \right) \times 100$ |
| Clocked synchronous mode (n = 0) | $B_0 = \frac{P\phi \times 10^6}{4 \times 2^{2n} \times (N + 1)}$ | — |
| Clocked synchronous mode (n = 1 to 3) | $B_0 = \frac{P\phi \times 10^6}{4 \times 2^{2n+1} \times (N + 1)}$ | — |
| Smart card interface mode (n = 0) | $B_0 = \frac{P\phi \times 10^6}{S \times 2^{2n+1} \times (N + 1)}$ | $\text{Error (\%)} = \left(\frac{B_0}{B_1} - 1 \right) \times 100$ |
| Smart card interface mode (n = 1 to 3) | $B_0 = \frac{P\phi \times 10^6}{S \times 2^{2n+2} \times (N + 1)}$ | $\text{Error (\%)} = \left(\frac{B_0}{B_1} - 1 \right) \times 100$ |

[Legend]

B_0 : Effective bit rate (bit/s) Actual transfer speed according to the register settings

B_1 : Logical bit rate (bit/s) Specified transfer speed of the target system

N: BRR setting for baud rate generator ($0 \leq N \leq 255$)

$P\phi$: Peripheral clock operating frequency (MHz)

n and S: Determined by the SMR settings shown in the following tables.

| SMR Setting | | |
|-------------|------|---|
| CKS1 | CKS0 | n |
| 0 | 0 | 0 |
| 0 | 1 | 1 |
| 1 | 0 | 2 |
| 1 | 1 | 3 |

| SMR Setting | | |
|-------------|------|-----|
| BCP1 | BCP0 | S |
| 0 | 0 | 32 |
| 0 | 1 | 64 |
| 1 | 0 | 372 |
| 1 | 1 | 256 |

Table 13.3 shows sample N settings in BRR in normal asynchronous mode. Table 13.4 shows the maximum bit rate for each frequency in normal asynchronous mode. Table 13.6 shows sample N settings in BRR in clocked synchronous mode. Table 13.8 shows sample N settings in BRR in smart card interface mode. Table 13.9 shows the maximum bit rate for each frequency in smart card interface mode. For details, refer to section 13.4.2, Receive Data Sampling Timing and Reception Margin in Asynchronous Mode and section 13.7.4, Receive Data Sampling Timing and Reception Margin. Tables 13.5 and 13.7 show the maximum bit rates with external clock input.

Table 13.3 BRR Settings for Various Bit Rates (Asynchronous Mode) (1)

| Logical Bit Rate (bit/s) | Operating Frequency P ϕ (MHz) | | | | | | | | | | | | | | |
|--------------------------------|------------------------------------|-----|-----------|---|-----|-----------|---|----|-----------|----|-----|-----------|----|-----|-----------|
| | 4 | | | 6 | | | 8 | | | 10 | | | 12 | | |
| | n | N | Error (%) | n | N | Error (%) | n | N | Error (%) | n | N | Error (%) | n | N | Error (%) |
| 110 | 1 | 140 | 0.74 | 1 | 212 | 0.03 | 2 | 70 | 0.03 | 2 | 88 | -0.25 | 2 | 106 | -0.44 |
| 150 | 1 | 103 | 0.16 | 1 | 155 | 0.16 | 2 | 51 | 0.16 | 2 | 64 | 0.16 | 2 | 77 | 0.16 |
| 300 | 1 | 51 | 0.16 | 1 | 77 | 0.16 | 2 | 25 | 0.16 | 1 | 129 | 0.16 | 2 | 38 | 0.16 |
| 600 | 1 | 25 | 0.16 | 1 | 38 | 0.16 | 2 | 12 | 0.16 | 1 | 64 | 0.16 | 1 | 77 | 0.16 |
| 1200 | 1 | 12 | 0.16 | 0 | 155 | 0.16 | 1 | 25 | 0.16 | 1 | 32 | -1.36 | 1 | 38 | 0.16 |
| 2400 | 0 | 51 | 0.16 | 0 | 77 | 0.16 | 1 | 12 | 0.16 | 0 | 129 | 0.16 | 0 | 155 | 0.16 |
| 4800 | 0 | 25 | 0.16 | 0 | 38 | 0.16 | 0 | 51 | 0.16 | 0 | 64 | 0.16 | 0 | 77 | 0.16 |
| 9600 | 0 | 12 | 0.16 | 0 | 19 | -2.34 | 0 | 25 | 0.16 | 0 | 32 | -1.36 | 0 | 38 | 0.16 |
| 14400 | 0 | 8 | -3.55 | 0 | 12 | 0.16 | 0 | 16 | 2.12 | 0 | 21 | -1.36 | 0 | 25 | 0.16 |
| 19200 | 0 | 6 | -6.99 | 0 | 9 | -2.34 | 0 | 12 | 0.16 | 0 | 15 | 1.73 | 0 | 19 | -2.34 |
| 28800 | 0 | 3 | 8.51 | 0 | 6 | -6.99 | 0 | 8 | -3.55 | 0 | 10 | -1.36 | 0 | 12 | 0.16 |
| 31250 | 0 | 3 | 0.00 | 0 | 5 | 0.00 | 0 | 7 | 0.00 | 0 | 9 | 0.00 | 0 | 11 | 0.00 |
| 38400 | 0 | 2 | 8.51 | 0 | 4 | -2.34 | 0 | 6 | -6.99 | 0 | 7 | 1.73 | 0 | 9 | -2.34 |

Table 13.3 BRR Settings for Various Bit Rates (Asynchronous Mode) (2)

| Logical Bit Rate (bit/s) | Operating Frequency P ϕ (MHz) | | | | | | | | | | | | | | |
|--------------------------------|------------------------------------|-----|-----------|----|-----|-----------|----|-----|-----------|----|-----|-----------|----|-----|-----------|
| | 14 | | | 16 | | | 18 | | | 20 | | | 22 | | |
| | n | N | Error (%) | n | N | Error (%) | n | N | Error (%) | n | N | Error (%) | n | N | Error (%) |
| 110 | 2 | 123 | 0.23 | 2 | 141 | 0.03 | 2 | 159 | -0.12 | 2 | 177 | -0.25 | 2 | 194 | 0.16 |
| 150 | 2 | 90 | 0.16 | 2 | 103 | 0.16 | 2 | 116 | 0.16 | 2 | 129 | 0.16 | 2 | 142 | 0.16 |
| 300 | 2 | 45 | -0.93 | 2 | 51 | 0.16 | 2 | 58 | -0.69 | 2 | 64 | 0.16 | 2 | 71 | -0.54 |
| 600 | 2 | 22 | -0.93 | 1 | 103 | 0.16 | 1 | 116 | 0.16 | 1 | 129 | 0.16 | 1 | 142 | 0.16 |
| 1200 | 1 | 45 | -0.93 | 1 | 51 | 0.16 | 1 | 58 | -0.69 | 1 | 64 | 0.16 | 1 | 71 | -0.54 |
| 2400 | 1 | 22 | -0.93 | 0 | 207 | 0.16 | 0 | 233 | 0.16 | 1 | 32 | -1.36 | 1 | 35 | -0.54 |
| 4800 | 0 | 90 | 0.16 | 0 | 103 | 0.16 | 0 | 116 | 0.16 | 0 | 129 | 0.16 | 0 | 142 | 0.16 |
| 9600 | 0 | 45 | -0.93 | 0 | 51 | 0.16 | 0 | 58 | -0.69 | 0 | 64 | 0.16 | 0 | 71 | -0.54 |
| 14400 | 0 | 29 | 1.27 | 0 | 34 | -0.79 | 0 | 38 | 0.16 | 0 | 42 | 0.94 | 0 | 47 | -0.54 |
| 19200 | 0 | 22 | -0.93 | 0 | 25 | 0.16 | 0 | 28 | 1.02 | 0 | 32 | -1.36 | 0 | 35 | -0.54 |
| 28800 | 0 | 14 | 1.27 | 0 | 16 | 2.12 | 0 | 19 | -2.34 | 0 | 21 | -1.36 | 0 | 23 | -0.54 |
| 31250 | 0 | 13 | 0.00 | 0 | 15 | 0.00 | 0 | 17 | 0.00 | 0 | 19 | 0.00 | 0 | 21 | 0.00 |
| 38400 | 0 | 10 | 3.57 | 0 | 12 | 0.16 | 0 | 14 | -2.34 | 0 | 15 | 1.73 | 0 | 17 | -0.54 |

Table 13.3 BRR Settings for Various Bit Rates (Asynchronous Mode) (3)

| Logical Bit Rate (bit/s) | Operating Frequency P ϕ (MHz) | | | | | | | | | | | | | | |
|--------------------------------|------------------------------------|-----|-----------|----|-----|-----------|----|-----|-----------|----|-----|-----------|----|-----|-----------|
| | 24 | | | 25 | | | 26 | | | 28 | | | 30 | | |
| | n | N | Error (%) | n | N | Error (%) | n | N | Error (%) | n | N | Error (%) | n | N | Error (%) |
| 110 | 2 | 212 | 0.03 | 2 | 221 | -0.02 | 2 | 230 | -0.08 | 2 | 248 | -0.17 | 3 | 66 | -0.62 |
| 150 | 2 | 155 | 0.16 | 2 | 162 | -0.15 | 2 | 168 | 0.16 | 2 | 181 | 0.16 | 2 | 194 | 0.16 |
| 300 | 2 | 77 | 0.16 | 2 | 80 | 0.47 | 2 | 84 | -0.43 | 2 | 90 | 0.16 | 2 | 97 | -0.35 |
| 600 | 1 | 155 | 0.16 | 1 | 162 | -0.15 | 1 | 168 | 0.16 | 1 | 181 | 0.16 | 2 | 48 | -0.35 |
| 1200 | 1 | 77 | 0.16 | 1 | 80 | 0.47 | 1 | 84 | -0.43 | 1 | 90 | 0.16 | 1 | 97 | -0.35 |
| 2400 | 1 | 38 | 0.16 | 1 | 40 | -0.76 | 1 | 41 | 0.76 | 1 | 45 | -0.93 | 1 | 48 | -0.35 |
| 4800 | 0 | 155 | 0.16 | 0 | 162 | -0.15 | 0 | 168 | 0.16 | 0 | 181 | 0.16 | 0 | 194 | 0.16 |
| 9600 | 0 | 77 | 0.16 | 0 | 80 | 0.47 | 0 | 84 | -0.43 | 0 | 90 | 0.16 | 0 | 97 | -0.35 |
| 14400 | 0 | 51 | 0.16 | 0 | 53 | 0.47 | 0 | 55 | 0.76 | 0 | 60 | -0.39 | 0 | 64 | 0.16 |
| 19200 | 0 | 38 | 0.16 | 0 | 40 | -0.76 | 0 | 41 | 0.76 | 0 | 45 | -0.93 | 0 | 48 | -0.35 |
| 28800 | 0 | 25 | 0.16 | 0 | 26 | 0.47 | 0 | 27 | 0.76 | 0 | 29 | 1.27 | 0 | 32 | -1.36 |
| 31250 | 0 | 23 | 0.00 | 0 | 24 | 0.00 | 0 | 25 | 0.00 | 0 | 27 | 0.00 | 0 | 29 | 0.00 |
| 38400 | 0 | 19 | -2.34 | 0 | 19 | 1.73 | 0 | 20 | 0.76 | 0 | 22 | -0.93 | 0 | 23 | 1.73 |

Table 13.3 BRR Settings for Various Bit Rates (Asynchronous Mode) (4)

| Logical Bit Rate (bit/s) | Operating Frequency P ϕ (MHz) | | | | | | | | | | | | | | |
|--------------------------------|------------------------------------|-----|-----------|----|-----|-----------|----|-----|-----------|----|-----|-----------|----|-----|-----------|
| | 32 | | | 34 | | | 36 | | | 38 | | | 40 | | |
| | n | N | Error (%) | n | N | Error (%) | n | N | Error (%) | n | N | Error (%) | n | N | Error (%) |
| 110 | 3 | 70 | 0.03 | 3 | 74 | 0.62 | 3 | 79 | -0.12 | 3 | 83 | 0.40 | 3 | 88 | -0.25 |
| 150 | 2 | 207 | 0.16 | 2 | 220 | 0.16 | 2 | 233 | 0.16 | 2 | 246 | 0.16 | 3 | 64 | 0.16 |
| 300 | 2 | 103 | 0.16 | 2 | 110 | -0.29 | 2 | 116 | 0.16 | 2 | 123 | -0.24 | 2 | 129 | 0.16 |
| 600 | 2 | 51 | 0.16 | 2 | 54 | 0.62 | 2 | 58 | -0.69 | 2 | 61 | -0.24 | 2 | 64 | 0.16 |
| 1200 | 1 | 103 | 0.16 | 1 | 110 | -0.29 | 1 | 116 | 0.16 | 1 | 123 | -0.24 | 1 | 129 | 0.16 |
| 2400 | 1 | 51 | 0.16 | 1 | 51 | 6.42 | 1 | 58 | -0.69 | 1 | 61 | -0.24 | 1 | 64 | 0.16 |
| 4800 | 0 | 207 | 0.16 | 0 | 220 | 0.16 | 0 | 234 | -0.27 | 0 | 246 | 0.16 | 1 | 32 | -1.36 |
| 9600 | 0 | 103 | 0.16 | 0 | 110 | -0.29 | 0 | 116 | 0.16 | 0 | 123 | -0.24 | 0 | 129 | 0.16 |
| 14400 | 0 | 68 | 0.64 | 0 | 73 | -0.29 | 0 | 77 | 0.16 | 0 | 81 | 0.57 | 0 | 86 | -0.22 |
| 19200 | 0 | 51 | 0.16 | 0 | 54 | 0.62 | 0 | 58 | -0.69 | 0 | 61 | -0.24 | 0 | 64 | 0.16 |
| 28800 | 0 | 34 | -0.79 | 0 | 36 | -0.29 | 0 | 38 | 0.16 | 0 | 40 | 0.57 | 0 | 42 | 0.94 |
| 31250 | 0 | 31 | 0.00 | 0 | 33 | 0.00 | 0 | 35 | 0.00 | 0 | 37 | 0.00 | 0 | 39 | 0.00 |
| 38400 | 0 | 25 | 0.16 | 0 | 27 | -1.18 | 0 | 28 | 1.02 | 0 | 30 | -0.24 | 0 | 32 | -1.36 |

Note: Settings with an error of 1% or less are recommended.

Table 13.4 Maximum Bit Rate for Each Frequency when Using Baud Rate Generator (Asynchronous Mode)

| Pϕ (MHz) | n | N | Maximum Bit Rate (bit/s) |
|---------------------------------|----------|----------|---------------------------------|
| 4 | 0 | 0 | 125000 |
| 8 | 0 | 0 | 250000 |
| 10 | 0 | 0 | 312500 |
| 12 | 0 | 0 | 375000 |
| 14 | 0 | 0 | 437500 |
| 16 | 0 | 0 | 500000 |
| 18 | 0 | 0 | 562500 |
| 20 | 0 | 0 | 625000 |
| 22 | 0 | 0 | 687500 |
| 24 | 0 | 0 | 750000 |
| 25 | 0 | 0 | 781250 |
| 26 | 0 | 0 | 812500 |
| 28 | 0 | 0 | 875000 |
| 30 | 0 | 0 | 937500 |
| 32 | 0 | 0 | 1000000 |
| 34 | 0 | 0 | 1062500 |
| 36 | 0 | 0 | 1125000 |
| 38 | 0 | 0 | 1187500 |
| 40 | 0 | 0 | 1250000 |

Table 13.5 Maximum Bit Rate with External Clock Input (Asynchronous Mode)

| Pϕ (MHz) | External Clock (MHz) | Maximum Bit Rate (bit/s) |
|---------------------------------|-----------------------------|---------------------------------|
| 4 | 1.0000 | 62500 |
| 6 | 1.5000 | 93750 |
| 8 | 2.0000 | 125000 |
| 10 | 2.5000 | 156250 |
| 12 | 3.0000 | 187500 |
| 14 | 3.5000 | 218750 |
| 16 | 4.0000 | 250000 |
| 18 | 4.5000 | 281250 |
| 20 | 5.0000 | 312500 |
| 22 | 5.5000 | 343750 |
| 24 | 6.0000 | 375000 |
| 25 | 6.2500 | 390625 |
| 26 | 6.5000 | 406250 |
| 28 | 7.0000 | 437500 |
| 30 | 7.5000 | 468750 |
| 32 | 8.0000 | 500000 |
| 34 | 8.5000 | 531250 |
| 36 | 9.0000 | 562500 |
| 38 | 9.5000 | 593750 |
| 40 | 10.0000 | 625000 |

Table 13.6 BRR Settings for Various Bit Rates (Clocked Synchronous Mode) (1)

| Logical Bit Rate (bit/s) | Operating Frequency P ϕ (MHz) | | | | | | | | | |
|--------------------------|------------------------------------|-----|---|-----|---|-----|----|-----|----|-----|
| | 4 | | 6 | | 8 | | 10 | | 12 | |
| | n | N | n | N | n | N | n | N | n | N |
| 250 | 2 | 124 | 2 | 187 | 2 | 249 | 3 | 77 | 3 | 93 |
| 500 | 1 | 249 | 2 | 93 | 2 | 124 | 2 | 155 | 2 | 187 |
| 1000 | 1 | 124 | 1 | 187 | 1 | 249 | 2 | 77 | 2 | 93 |
| 2500 | 1 | 49 | 1 | 74 | 1 | 99 | 1 | 124 | 1 | 149 |
| 5000 | 1 | 24 | — | — | 1 | 49 | 1 | 61 | 1 | 74 |
| 10000 | 0 | 99 | 0 | 149 | 1 | 24 | 0 | 249 | — | — |
| 25000 | 0 | 39 | 0 | 59 | 1 | 9 | 0 | 99 | 1 | 14 |
| 50000 | 0 | 19 | 0 | 29 | 1 | 4 | 0 | 49 | 0 | 59 |
| 100000 | 0 | 9 | 0 | 14 | 0 | 19 | 0 | 24 | 0 | 29 |
| 250000 | 0 | 3 | 0 | 5 | 0 | 7 | 0 | 9 | 0 | 11 |
| 500000 | 0 | 1 | 0 | 2 | 0 | 3 | 0 | 4 | 0 | 5 |
| 1000000 | 0 | 0* | — | — | 0 | 1 | — | — | 0 | 2 |
| 2500000 | — | — | — | — | — | — | 0 | 0* | — | — |
| 5000000 | — | — | — | — | — | — | — | — | — | — |

Table 13.6 BRR Settings for Various Bit Rates (Clocked Synchronous Mode) (2)

| Logical Bit Rate (bit/s) | Operating Frequency P ϕ (MHz) | | | | | | | | | |
|--------------------------|------------------------------------|-----|----|-----|----|-----|----|-----|----|-----|
| | 14 | | 16 | | 18 | | 20 | | 22 | |
| | n | N | n | N | n | N | n | N | n | N |
| 250 | 3 | 108 | 3 | 124 | 3 | 140 | 3 | 155 | 3 | 171 |
| 500 | 2 | 218 | 2 | 249 | 3 | 69 | 3 | 77 | 3 | 85 |
| 1000 | 2 | 108 | 2 | 124 | 2 | 140 | 2 | 155 | 3 | 42 |
| 2500 | 1 | 174 | 2 | 49 | 1 | 224 | 1 | 249 | 2 | 68 |
| 5000 | 1 | 86 | 2 | 24 | 1 | 112 | 1 | 124 | 1 | 137 |
| 10000 | 1 | 43 | 1 | 49 | 1 | 55 | 1 | 62 | 1 | 68 |
| 25000 | 0 | 139 | 1 | 19 | 0 | 179 | 1 | 24 | 0 | 219 |
| 50000 | 0 | 69 | 1 | 9 | 0 | 89 | 0 | 99 | 0 | 109 |
| 100000 | 0 | 34 | 1 | 4 | 0 | 44 | 0 | 49 | 0 | 54 |
| 250000 | 0 | 13 | 1 | 1 | 0 | 17 | 0 | 19 | 0 | 21 |
| 500000 | 0 | 6 | 1 | 0 | 0 | 8 | 0 | 9 | 0 | 10 |
| 1000000 | — | — | 0 | 3 | — | — | 0 | 4 | — | — |
| 2500000 | — | — | — | — | — | — | 0 | 1 | — | — |
| 5000000 | — | — | — | — | — | — | 0 | 0* | — | — |

Table 13.6 BRR Settings for Various Bit Rates (Clocked Synchronous Mode) (3)

| Logical Bit Rate (bit/s) | Operating Frequency P ϕ (MHz) | | | | | | | | | |
|--------------------------|------------------------------------|-----|----|-----|----|-----|----|-----|----|-----|
| | 24 | | 25 | | 26 | | 28 | | 30 | |
| | n | N | n | N | n | N | n | N | n | N |
| 250 | 3 | 187 | 3 | 194 | 3 | 202 | 3 | 218 | 3 | 233 |
| 500 | 3 | 93 | 3 | 97 | 3 | 101 | 3 | 108 | 3 | 116 |
| 1000 | 2 | 187 | 2 | 194 | 2 | 202 | 2 | 218 | 2 | 233 |
| 2500 | 2 | 74 | 2 | 77 | 2 | 80 | 2 | 86 | 2 | 93 |
| 5000 | 1 | 149 | 1 | 155 | 1 | 162 | 1 | 174 | 1 | 187 |
| 10000 | 1 | 74 | 1 | 77 | 1 | 80 | 1 | 86 | 1 | 93 |
| 25000 | 1 | 29 | 0 | 249 | — | — | 1 | 34 | — | — |
| 50000 | 1 | 14 | 0 | 124 | 0 | 129 | 0 | 139 | 0 | 149 |
| 100000 | 0 | 59 | 0 | 62 | 0 | 64 | 0 | 69 | 0 | 74 |
| 250000 | 0 | 23 | 0 | 24 | 0 | 25 | 0 | 27 | 0 | 29 |
| 500000 | 0 | 11 | — | — | 0 | 12 | 0 | 13 | 0 | 14 |
| 1000000 | 0 | 5 | — | — | — | — | 0 | 6 | — | — |
| 2500000 | — | — | — | — | — | — | — | — | 0 | 2 |
| 5000000 | — | — | — | — | — | — | — | — | — | — |

Table 13.6 BRR Settings for Various Bit Rates (Clocked Synchronous Mode) (4)

| Logical Bit Rate (bit/s) | Operating Frequency P ϕ (MHz) | | | | | | | | | |
|--------------------------|------------------------------------|-----|----|-----|----|-----|----|-----|----|-----|
| | 32 | | 34 | | 36 | | 38 | | 40 | |
| | n | N | n | N | n | N | n | N | n | N |
| 250 | 3 | 249 | — | — | — | — | — | — | — | — |
| 500 | 3 | 124 | 3 | 132 | 3 | 140 | 3 | 147 | 3 | 155 |
| 1000 | 2 | 249 | 3 | 65 | 3 | 69 | 3 | 73 | 3 | 77 |
| 2500 | 2 | 99 | 2 | 105 | 2 | 112 | 2 | 118 | 2 | 124 |
| 5000 | 2 | 49 | 1 | 212 | 1 | 224 | 1 | 237 | 1 | 249 |
| 10000 | 2 | 24 | 1 | 105 | 1 | 112 | 1 | 118 | 1 | 124 |
| 25000 | 2 | 9 | — | — | 1 | 44 | — | — | 1 | 49 |
| 50000 | 2 | 4 | 0 | 169 | 0 | 179 | 0 | 189 | 1 | 24 |
| 100000 | 1 | 9 | 0 | 84 | 0 | 89 | 0 | 94 | 0 | 99 |
| 250000 | 1 | 3 | 0 | 33 | 0 | 35 | 0 | 37 | 0 | 39 |
| 500000 | 1 | 1 | 0 | 16 | 0 | 17 | 0 | 18 | 0 | 19 |
| 1000000 | 1 | 0 | — | — | 0 | 8 | — | — | 0 | 9 |
| 2500000 | — | — | — | — | — | — | — | — | 0 | 3 |
| 5000000 | — | — | — | — | — | — | — | — | 0 | 1 |

[Legend]

— : Can be set, but there will be a degree of error.

* : Continuous transfer is not possible.

Table 13.7 Maximum Bit Rate with External Clock Input (Clocked Synchronous Mode)

| Pϕ (MHz) | External Clock (MHz) | Maximum Bit Rate (bit/s) |
|---------------------------------|-----------------------------|---------------------------------|
| 4 | 0.6667 | 666666.7 |
| 6 | 1.0000 | 1000000.0 |
| 8 | 1.3333 | 1333333.3 |
| 10 | 1.6667 | 1666666.7 |
| 12 | 2.0000 | 2000000.0 |
| 14 | 2.3333 | 2333333.3 |
| 16 | 2.6667 | 2666666.7 |
| 18 | 3.0000 | 3000000.0 |
| 20 | 3.3333 | 3333333.3 |
| 22 | 3.6667 | 3666666.7 |
| 24 | 4.0000 | 4000000.0 |
| 25 | 4.1667 | 4166666.7 |
| 26 | 4.3333 | 4333333.3 |
| 28 | 4.6667 | 4666666.7 |
| 30 | 5.0000 | 5000000.0 |
| 32 | 5.3333 | 5333333.3 |
| 34 | 5.6667 | 5666666.7 |
| 36 | 6.0000 | 6000000.0 |
| 38 | 6.3333 | 6333333.3 |
| 40 | 6.6667 | 6666666.7 |

Table 13.8 Examples of Bit Rate for Various BRR Settings (Smart Card Interface Mode)
(When $n = 0$ and $S = 372$)

| Bit Rate (bps) | Operating Frequency $P\phi$ (MHz) | | | | | | | | | |
|-------------------|-----------------------------------|-----------|---|-----------|----|-----------|----|-----------|----|-----------|
| | 4 | | 8 | | 16 | | 24 | | 25 | |
| | N | Error (%) | N | Error (%) | N | Error (%) | N | Error (%) | N | Error (%) |
| 9600 | 0 | 44 | 0 | 12 | 1 | 12 | 2 | 12 | 3 | 12 |

| Bit Rate (bps) | Operating Frequency $P\phi$ (MHz) | | | |
|-------------------|-----------------------------------|-----------|----|-----------|
| | 32 | | 40 | |
| | N | Error (%) | N | Error (%) |
| 9600 | 3 | 12 | 3 | 40 |

Table 13.9 Maximum Bit Rate at Various Frequencies (Smart Card Interface Mode)
(when $S = 372$)

| $P\phi$ (MHz) | Maximum Bit Rate (bps) | n | N |
|---------------|------------------------|---|---|
| 4 | 5376 | 0 | 0 |
| 8 | 10753 | 0 | 0 |
| 16 | 21505 | 0 | 0 |
| 24 | 32258 | 0 | 0 |
| 25 | 33602 | 0 | 0 |
| 32 | 43011 | 0 | 0 |
| 40 | 53763 | 0 | 0 |

13.4 Operation in Asynchronous Mode

Figure 13.2 shows the general format for asynchronous serial communication. One frame consists of a start bit (low level), followed by data, a parity bit, and finally stop bits (high level). In asynchronous serial communication, the transmission line is usually held in the mark state (high level). The SCI monitors the communication line, and when it goes to the space state (low level), recognizes a start bit and starts serial communication. Inside the SCI, the transmitter and receiver are independent units, enabling full-duplex communication. Both the transmitter and the receiver also have a double-buffered structure, so that data can be read or written during transmission or reception, enabling continuous data transfer. In asynchronous mode, the SCI performs synchronization at the falling edge of the start bit in reception. The SCI samples the data on the 8th pulse of a clock with a frequency of 16 times the length of one bit, so that the transfer data is latched at the center of each bit.

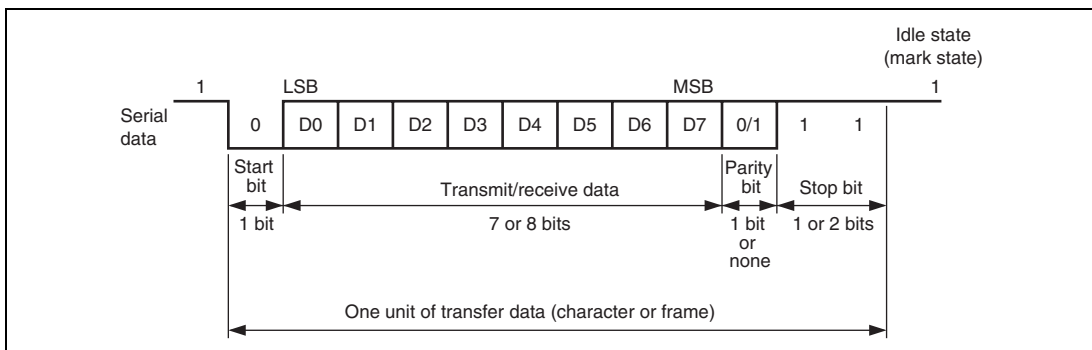

Figure 13.2 Data Format in Asynchronous Communication (Example with 8-Bit Data, Parity, Two Stop Bits)

13.4.1 Data Transfer Format

Table 13.10 shows the data transfer formats that can be used in asynchronous mode. Any of 12 transfer formats can be selected according to the SMR setting. For details on the multiprocessor bit, refer to section 13.5, Multiprocessor Communication Function.

Table 13.10 Serial Transfer Formats (Asynchronous Mode)

| SMR Settings | | | | Serial Transfer Format and Frame Length | | | | | | | | | | | | |
|--------------|----|----|------|---|------------|---|---|---|---|---|---|------|------|------|------|--|
| CHR | PE | MP | STOP | 1 | 2 | 3 | 4 | 5 | 6 | 7 | 8 | 9 | 10 | 11 | 12 | |
| 0 | 0 | 0 | 0 | S | 8-bit data | | | | | | | | STOP | | | |
| 0 | 0 | 0 | 1 | S | 8-bit data | | | | | | | | STOP | STOP | | |
| 0 | 1 | 0 | 0 | S | 8-bit data | | | | | | | | P | STOP | | |
| 0 | 1 | 0 | 1 | S | 8-bit data | | | | | | | | P | STOP | STOP | |
| 1 | 0 | 0 | 0 | S | 7-bit data | | | | | | | STOP | | | | |
| 1 | 0 | 0 | 1 | S | 7-bit data | | | | | | | STOP | STOP | | | |
| 1 | 1 | 0 | 0 | S | 7-bit data | | | | | | | P | STOP | | | |
| 1 | 1 | 0 | 1 | S | 7-bit data | | | | | | | P | STOP | STOP | | |
| 0 | X | 1 | 0 | S | 8-bit data | | | | | | | | MPB | STOP | | |
| 0 | X | 1 | 1 | S | 8-bit data | | | | | | | | MPB | STOP | STOP | |
| 1 | X | 1 | 0 | S | 7-bit data | | | | | | | MPB | STOP | | | |
| 1 | X | 1 | 1 | S | 7-bit data | | | | | | | MPB | STOP | STOP | | |

[Legend]

S: Start bit

STOP: Stop bit

P: Parity bit

MPB: Multiprocessor bit

X: Don't care

13.4.2 Receive Data Sampling Timing and Reception Margin in Asynchronous Mode

In asynchronous mode, the SCI operates on a basic clock with a frequency of 16 times the bit rate. In reception, the SCI samples the falling edge of the start bit using the basic clock, and performs internal synchronization. Receive data is latched internally at the rising edge of the 8th pulse of the basic clock as shown in figure 13.3. Thus the reception margin in asynchronous mode is given by formula (1) below.

$$M = \left\{ \left(0.5 - \frac{1}{2N} \right) - \frac{(D - 0.5)}{N} - (L - 0.5) F \right\} \times 100\% \quad \text{..... Formula (1)}$$

Where M: Reception margin (%)
 N: Ratio of bit rate to clock (N = 16)
 D: Clock duty (D = 0 to 1.0)
 L: Frame length (L = 9 to 12)
 F: Absolute value of clock rate deviation

Assuming values of F = 0 and D = 0.5 in formula (1), a reception margin is given by formula below.

$$M = \{ 0.5 - 1/(2 \times 16) \} \times 100 [\%] = 46.875\%$$

However, this is only the computed value, and a margin of 20% to 30% should be allowed in system design.

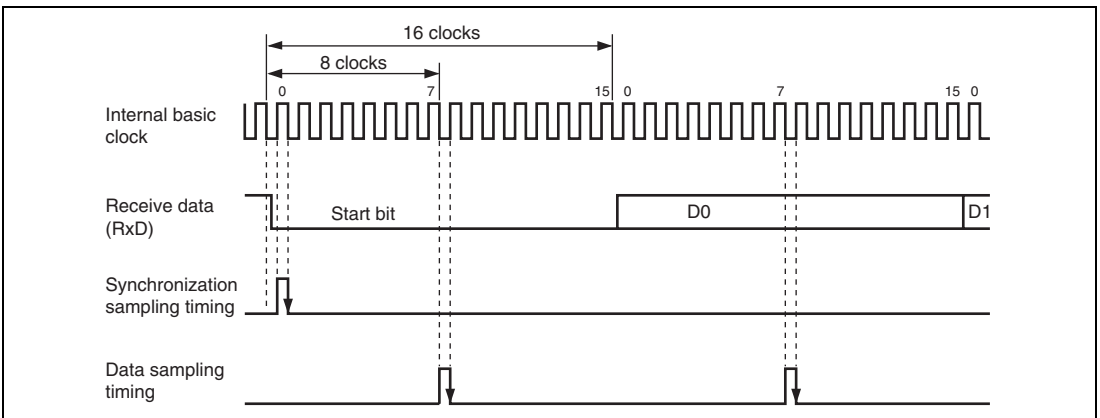

Figure 13.3 Receive Data Sampling Timing in Asynchronous Mode

13.4.3 Clock

Either an internal clock generated by the on-chip baud rate generator or an external clock input at the SCK pin can be selected as the SCI's serial clock, according to the setting of the C/A bit in SMR and the CKE1 and CKE0 bits in SCR. When an external clock is input at the SCK pin, the clock frequency should be 16 times the bit rate used.

When the SCI is operated on an internal clock, the clock can be output from the SCK pin. The frequency of the clock output in this case is equal to the bit rate, and the phase is such that the rising edge of the clock is in the middle of the transmit data, as shown in figure 13.4.

The clock must not be stopped during operation.

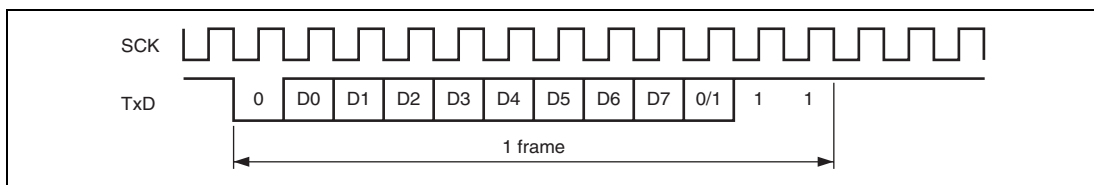

Figure 13.4 Relation between Output Clock and Transmit Data Phase (Asynchronous Mode)

13.4.4 SCI Initialization (Asynchronous Mode)

Before transmitting and receiving data, you should first clear the TE and RE bits in SCR to 0, then initialize the SCI as described below. When the operating mode, transfer format, etc., is changed, the TE and RE bits must be cleared to 0 before making the change using the following procedure. When the TE bit is cleared to 0, the TDRE flag is set to 1. Note that clearing the RE bit to 0 does not initialize the contents of the RDRF, PER, FER, and ORER flags, or the contents of RDR. When the external clock is used in asynchronous mode, the clock must be supplied even during initialization.

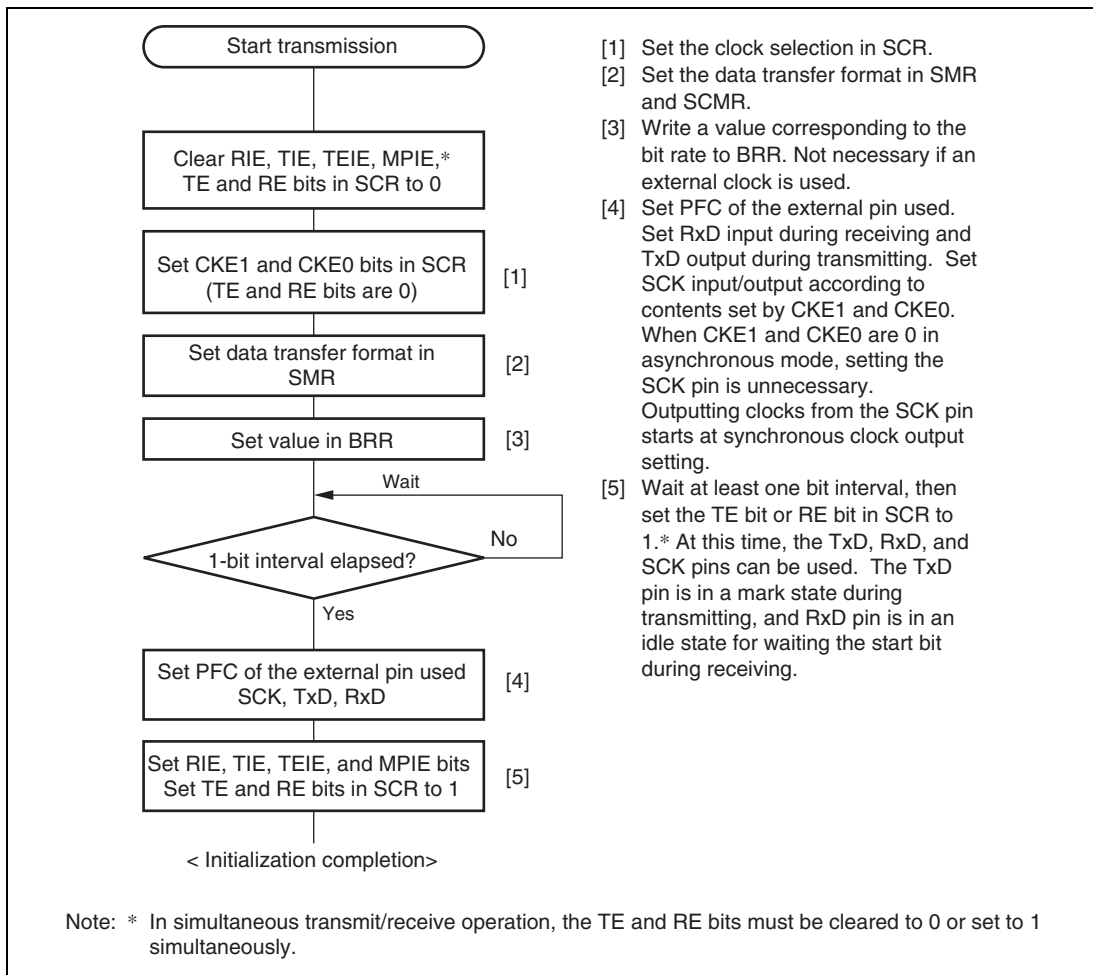
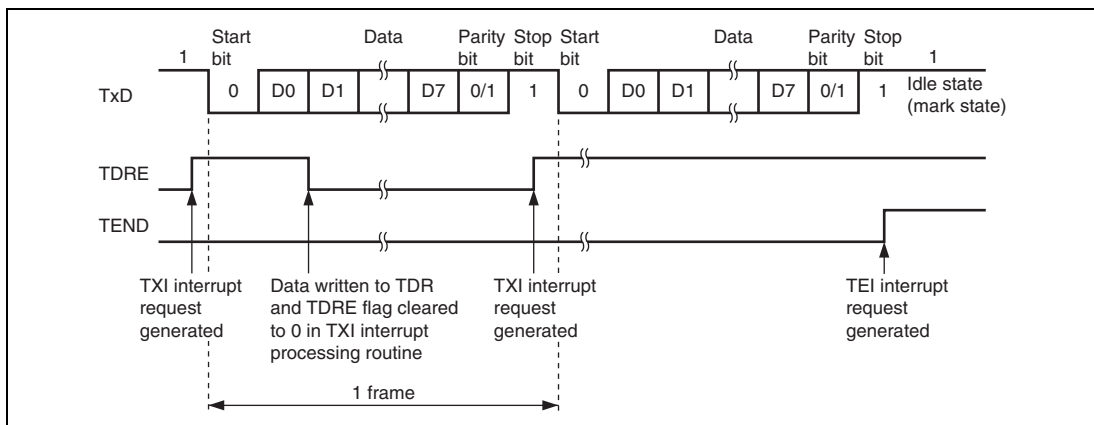

Figure 13.5 Sample SCI Initialization Flowchart

13.4.5 Data Transmission (Asynchronous Mode)

Figure 13.6 shows an example of the operation for transmission in asynchronous mode. In transmission, the SCI operates as described below.

1. The SCI monitors the TDRE flag in SSR, and if it is cleared to 0, recognizes that data has been written to TDR, and transfers the data from TDR to TSR.
2. After transferring data from TDR to TSR, the SCI sets the TDRE flag to 1 and starts transmission. If the TIE bit is set to 1 at this time, a transmit data empty interrupt request (TXI) is generated. Because the TXI interrupt routine writes the next transmit data to TDR before transmission of the current transmit data has finished, continuous transmission can be enabled.
3. Data is sent from the TxD pin in the following order: start bit, transmit data, parity bit or multiprocessor bit (may be omitted depending on the format), and stop bit.
4. The SCI checks the TDRE flag at the timing for sending the stop bit.
5. If the TDRE flag is 0, the data is transferred from TDR to TSR, the stop bit is sent, and then serial transmission of the next frame is started.
6. If the TDRE flag is 1, the TEND flag in SSR is set to 1, the stop bit is sent, and then the “mark state” is entered in which 1 is output. If the TEIE bit in SCR is set to 1 at this time, a TEI interrupt request is generated.



**Figure 13.6 Example of Operation in Transmission in Asynchronous Mode
(Example with 8-Bit Data, Parity, One Stop Bit)**

Figure 13.7 shows a sample flowchart for transmission in asynchronous mode.

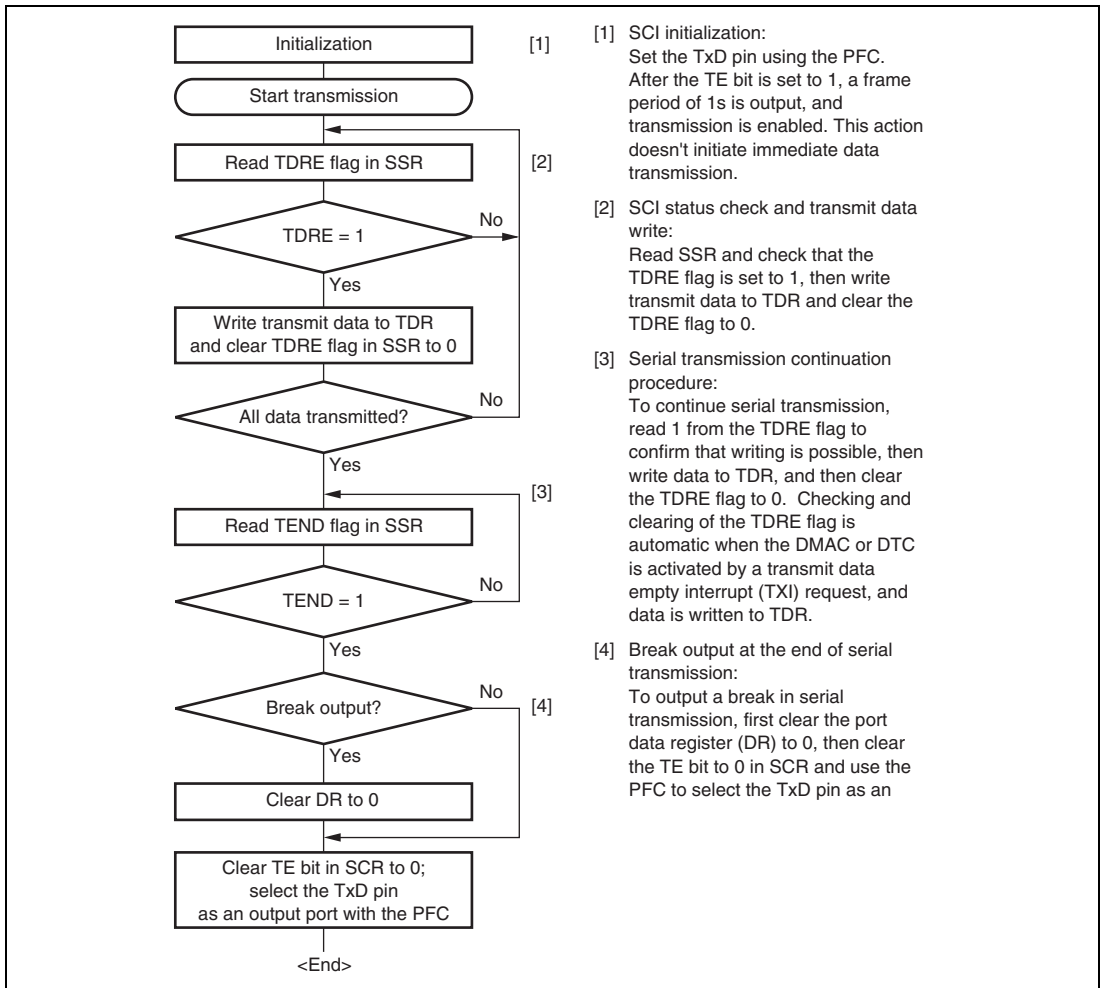
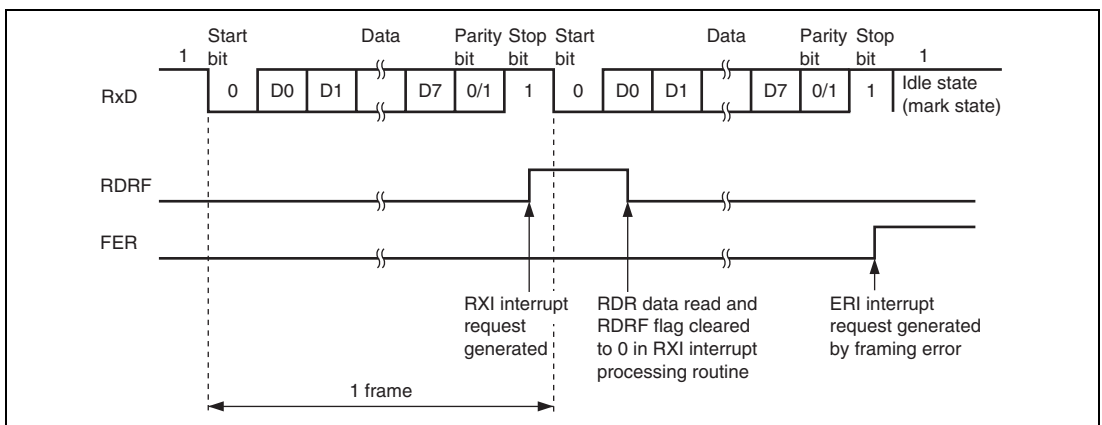

Figure 13.7 Sample Serial Transmission Flowchart

13.4.6 Serial Data Reception (Asynchronous Mode)

Figure 13.8 shows an example of the operation for reception in asynchronous mode. In serial reception, the SCI operates as described below.

1. The SCI monitors the communication line, and if a start bit is detected, performs internal synchronization, receives receive data in RSR, and checks the parity bit and stop bit.
2. If an overrun error (when reception of the next data is completed while the RDRF flag is still set to 1) occurs, the OER bit in SSR is set to 1. If the RIE bit in SCR is set to 1 at this time, an ERI interrupt request is generated. Receive data is not transferred to RDR. The RDRF flag remains to be set to 1.
3. If a parity error is detected, the PER bit in SSR is set to 1 and receive data is transferred to RDR. If the RIE bit in SCR is set to 1 at this time, an ERI interrupt request is generated.
4. If a framing error (when the stop bit is 0) is detected, the FER bit in SSR is set to 1 and receive data is transferred to RDR. If the RIE bit in SCR is set to 1 at this time, an ERI interrupt request is generated.
5. If reception finishes successfully, the RDRF bit in SSR is set to 1, and receive data is transferred to RDR. If the RIE bit in SCR is set to 1 at this time, an RXI interrupt request is generated. Because the RXI interrupt processing routine reads the receive data transferred to RDR before reception of the next receive data has finished, continuous reception can be enabled.



**Figure 13.8 Example of SCI Operation in Reception
(Example with 8-Bit Data, Parity, One Stop Bit)**

Table 13.11 shows the states of the SSR status flags and receive data handling when a receive error is detected. If a receive error is detected, the RDRF flag retains its state before receiving data. Reception cannot be resumed while a receive error flag is set to 1. Accordingly, clear the OER, FER, PER, and RDRF bits to 0 before resuming reception. Figure 13.9 shows a sample flow chart for serial data reception.

Table 13.11 SSR Status Flags and Receive Data Handling

| SSR Status Flag | | | | Receive Data | Receive Error Type |
|-----------------|-----|-----|-----|--------------------|---|
| RDRF* | OER | FER | PER | | |
| 1 | 1 | 0 | 0 | Lost | Overflow error |
| 0 | 0 | 1 | 0 | Transferred to RDR | Framing error |
| 0 | 0 | 0 | 1 | Transferred to RDR | Parity error |
| 1 | 1 | 1 | 0 | Lost | Overflow error + framing error |
| 1 | 1 | 0 | 1 | Lost | Overflow error + parity error |
| 0 | 0 | 1 | 1 | Transferred to RDR | Framing error + parity error |
| 1 | 1 | 1 | 1 | Lost | Overflow error + framing error + parity error |

Note: * The RDRF flag retains its state before data reception.

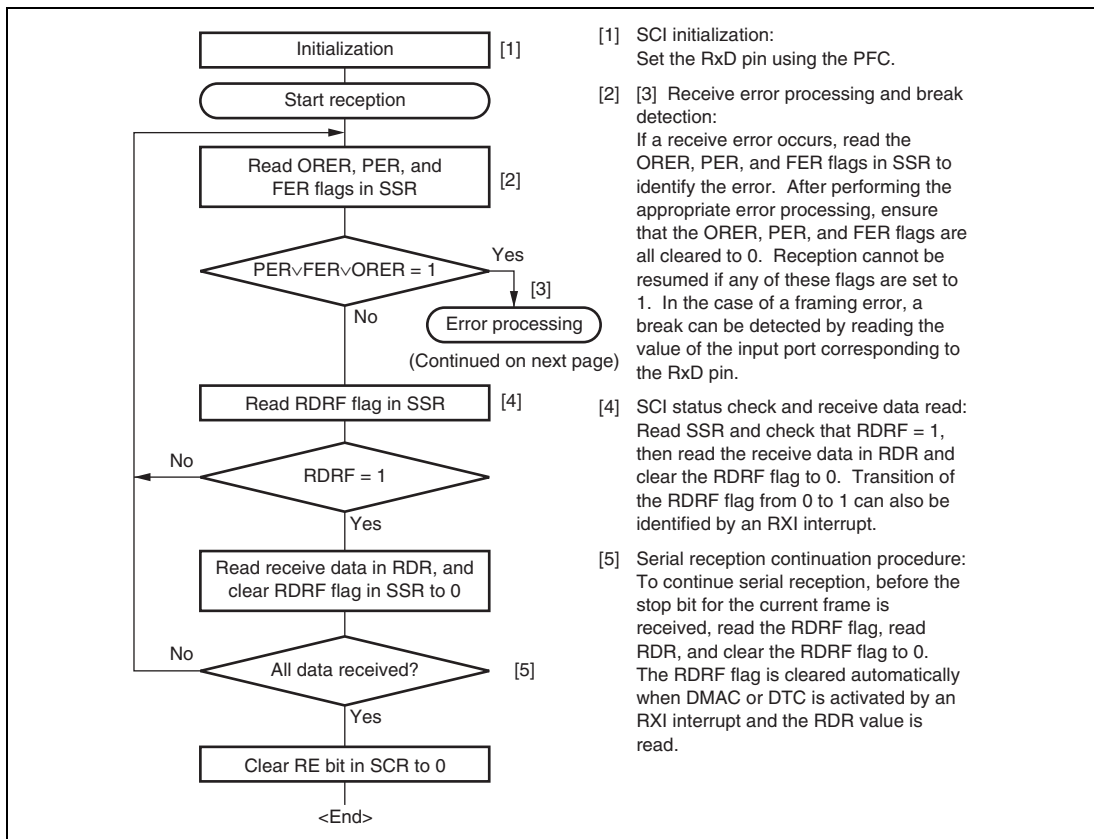

Figure 13.9 Sample Serial Reception Data Flowchart (1)

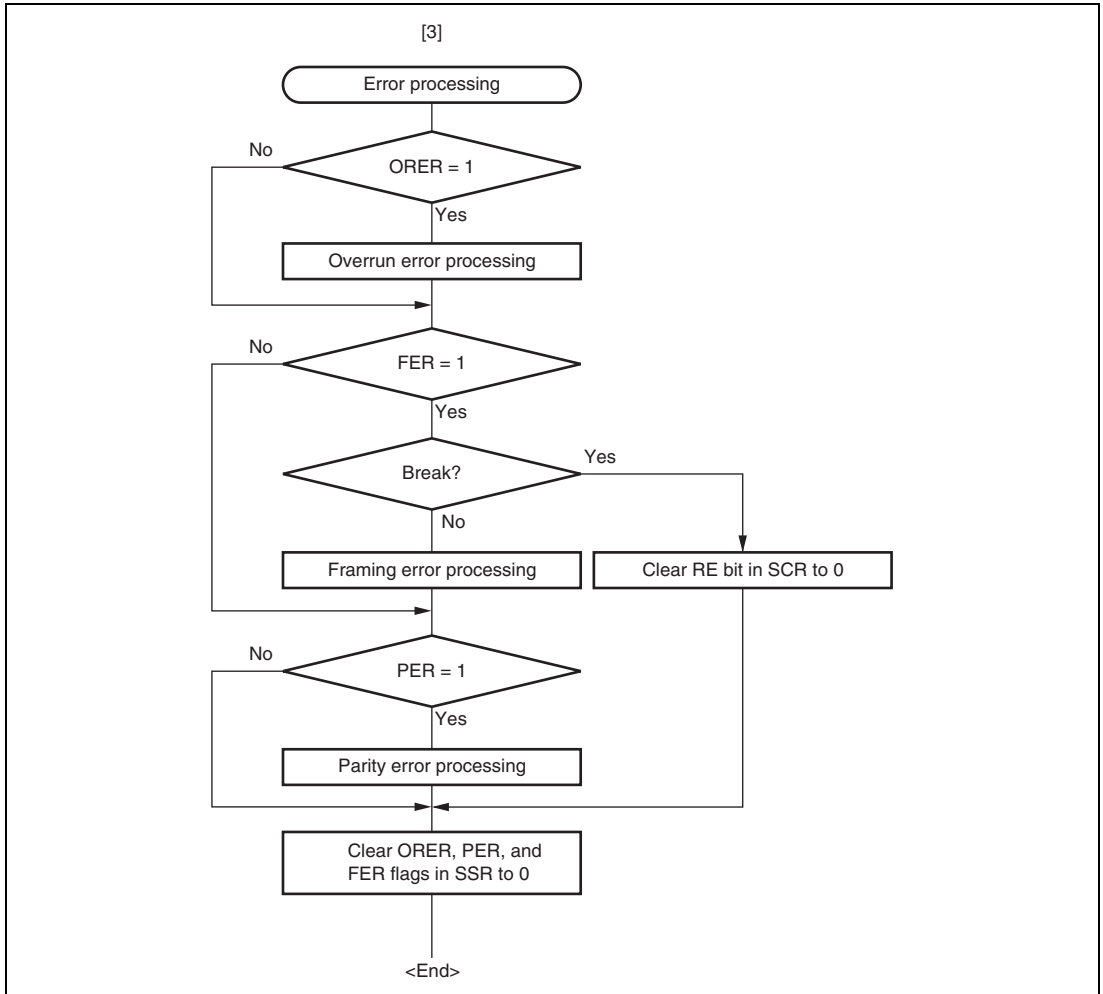

Figure 13.9 Sample Serial Reception Data Flowchart (2)

13.5 Multiprocessor Communication Function

Use of the multiprocessor communication function enables data transfer to be performed among a number of processors sharing communication lines by means of asynchronous serial communication using the multiprocessor format, in which a multiprocessor bit is added to the transfer data. When multiprocessor communication is carried out, each receiving station is addressed by a unique ID code. The serial communication cycle consists of two component cycles: an ID transmission cycle which specifies the receiving station, and a data transmission cycle. The multiprocessor bit is used to differentiate between the ID transmission cycle and the data transmission cycle. If the multiprocessor bit is 1, the cycle is an ID transmission cycle, and if the multiprocessor bit is 0, the cycle is a data transmission cycle. Figure 13.10 shows an example of inter-processor communication using the multiprocessor format. The transmitting station first sends the ID code of the receiving station with which it wants to perform serial communication as data with a 1 multiprocessor bit added. It then sends transmit data as data with a 0 multiprocessor bit added. The receiving station skips data until data with a 1 multiprocessor bit is sent. When data with a 1 multiprocessor bit is received, the receiving station compares that data with its own ID. The station whose ID matches then receives the data sent next. Stations whose ID does not match continue to skip data until data with a 1 multiprocessor bit is again received.

The SCI uses the MPIE bit in SCR to implement this function. When the MPIE bit is set to 1, transfer of receive data from RSR to RDR, error flag detection, and setting the SSR status flags, RDRF, FER, and OER to 1 are inhibited until data with a 1 multiprocessor bit is received. On reception of receive character with a 1 multiprocessor bit, the MPBR bit in SSR is set to 1 and the MPIE bit is automatically cleared, thus normal reception is resumed. If the RIE bit in SCR is set to 1 at this time, an RXI interrupt is generated.

When the multiprocessor format is selected, the parity bit setting is invalid. All other bit settings are the same as those in normal asynchronous mode. The clock used for multiprocessor communication is the same as that in normal asynchronous mode.

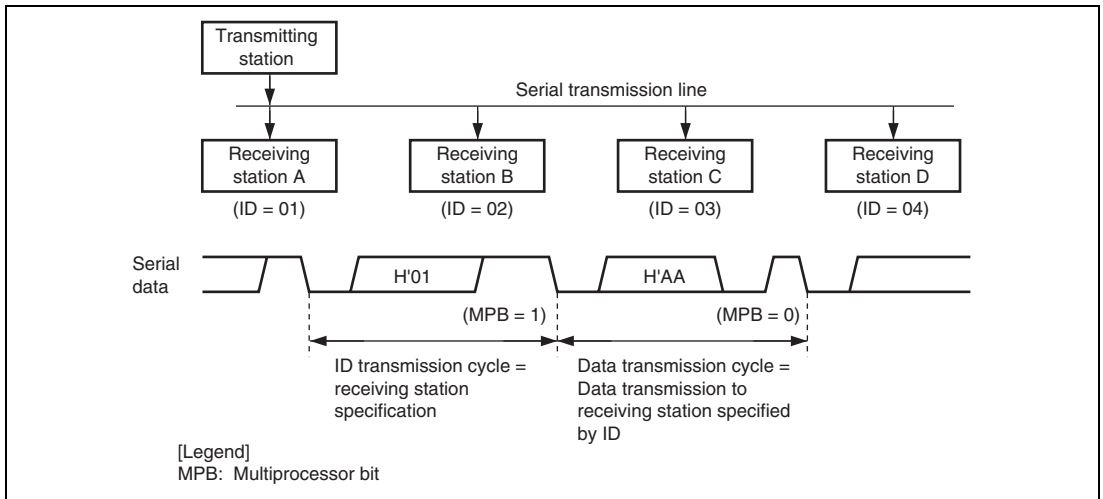

**Figure 13.10 Example of Communication Using Multiprocessor Format
(Transmission of Data H'AA to Receiving Station A)**

13.5.1 Multiprocessor Serial Data Transmission

Figure 13.11 shows a sample flowchart for multiprocessor serial data transmission. For an ID transmission cycle, set the MPBT bit in SSR to 1 before transmission. For a data transmission cycle, clear the MPBT bit in SSR to 0 before transmission. All other SCI operations are the same as those in asynchronous mode.

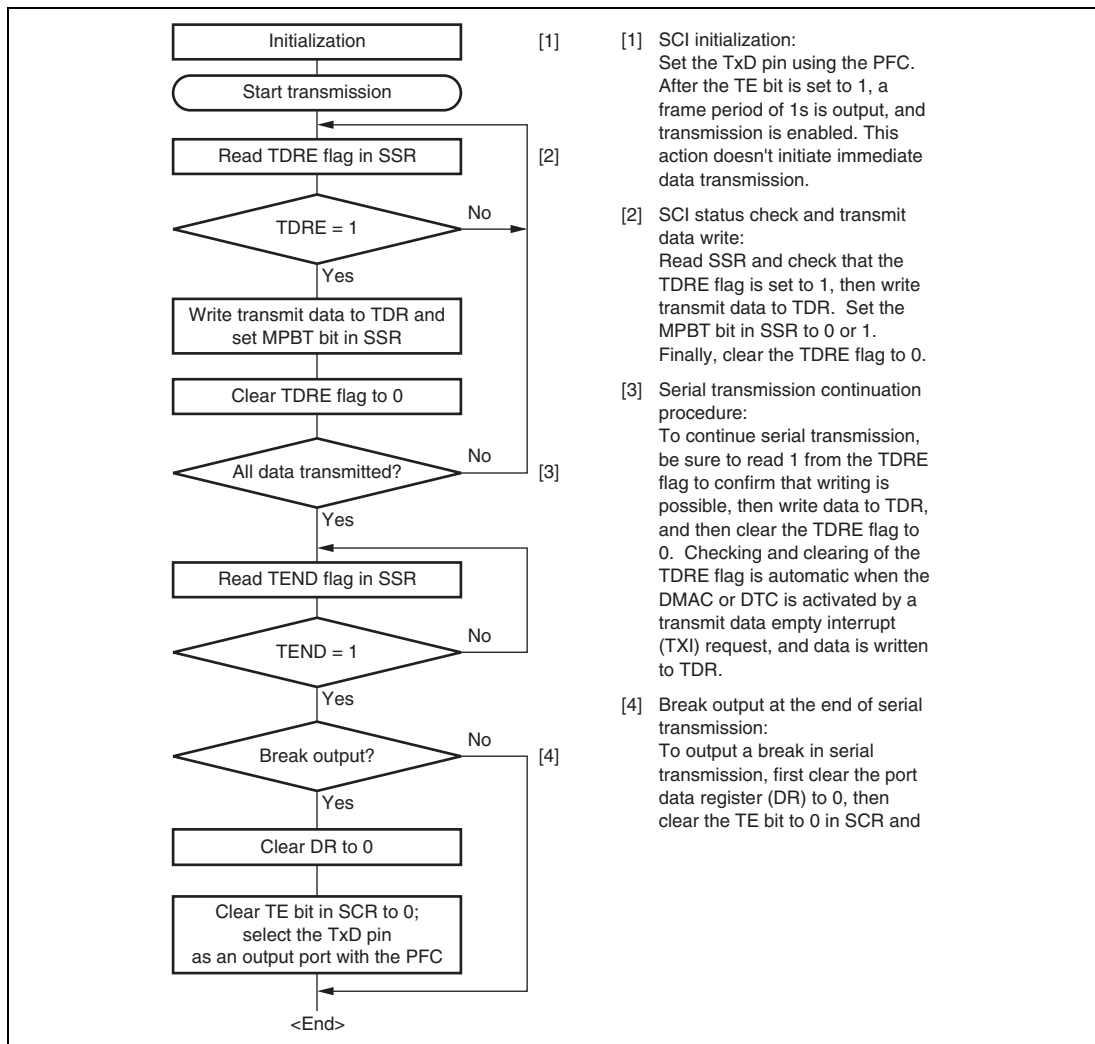

Figure 13.11 Sample Multiprocessor Serial Transmission Flowchart

13.5.2 Multiprocessor Serial Data Reception

Figure 13.13 shows a sample flowchart for multiprocessor serial data reception. If the MPIE bit in SCR is set to 1, data is skipped until data with a 1 multiprocessor bit is sent. On receiving data with a 1 multiprocessor bit, the receive data is transferred to RDR. An RXI interrupt request is generated at this time. All other SCI operations are the same as in asynchronous mode. Figure 13.12 shows an example of SCI operation for multiprocessor format reception.

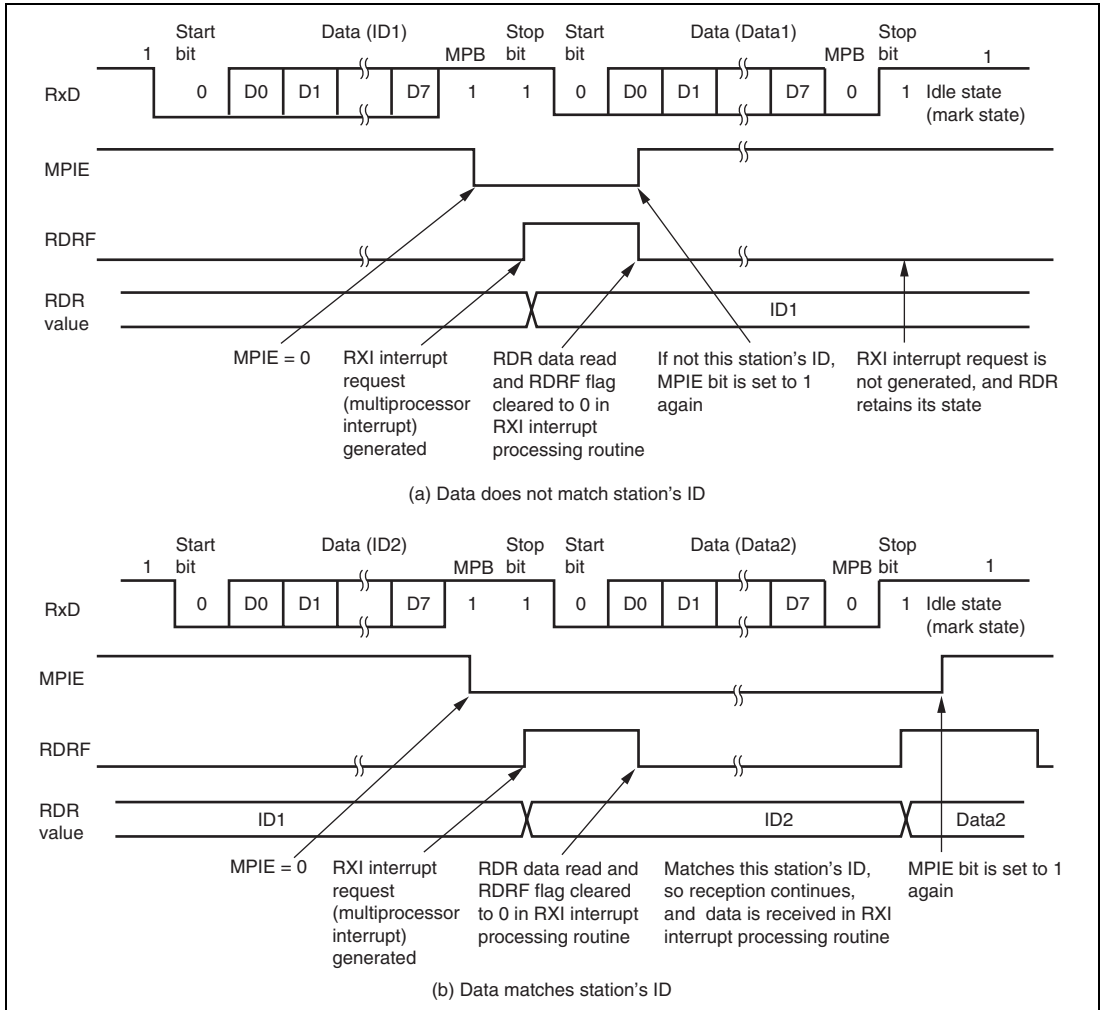

Figure 13.12 Example of SCI Operation in Reception
(Example with 8-Bit Data, Multiprocessor Bit, One Stop Bit)

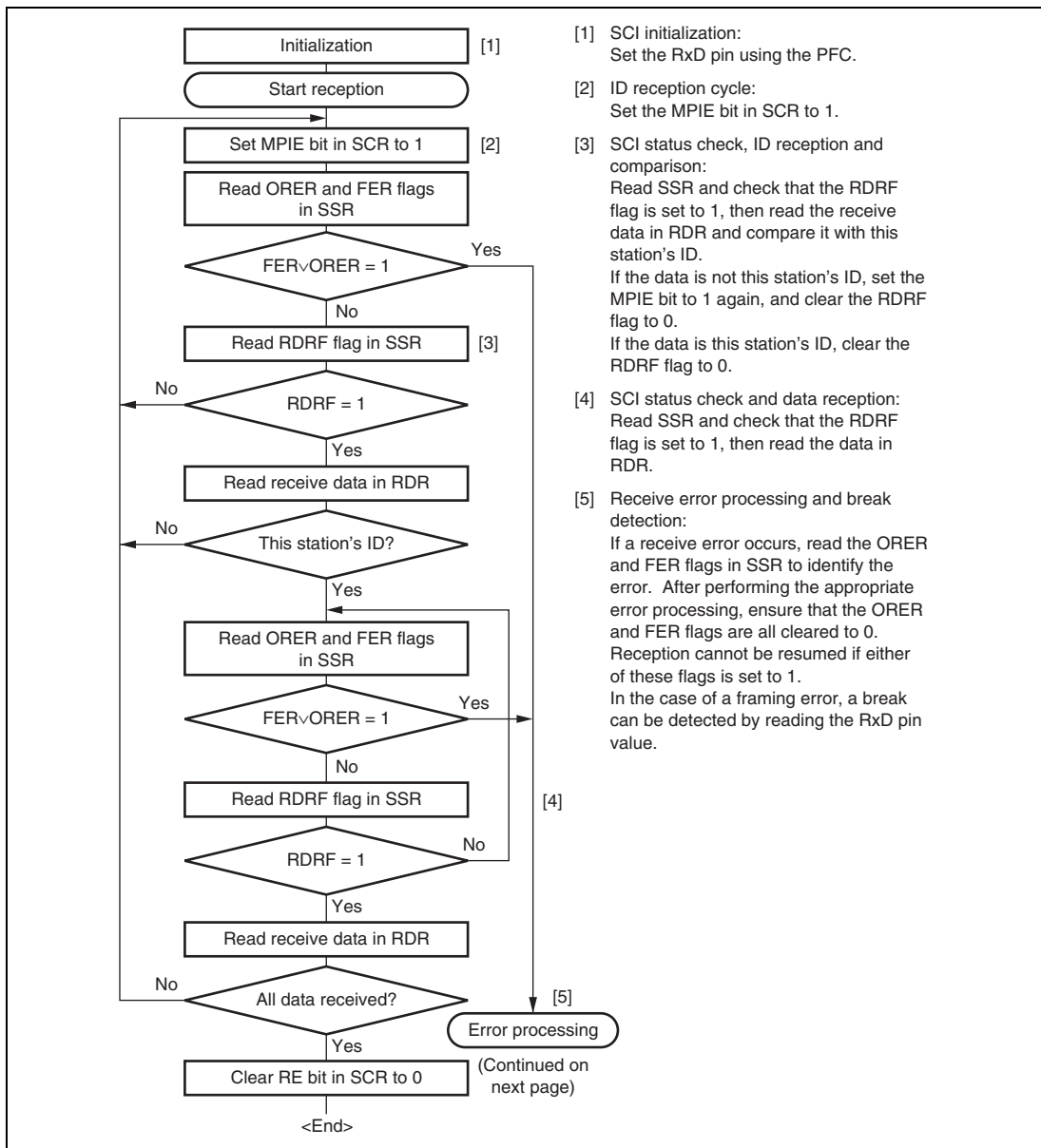
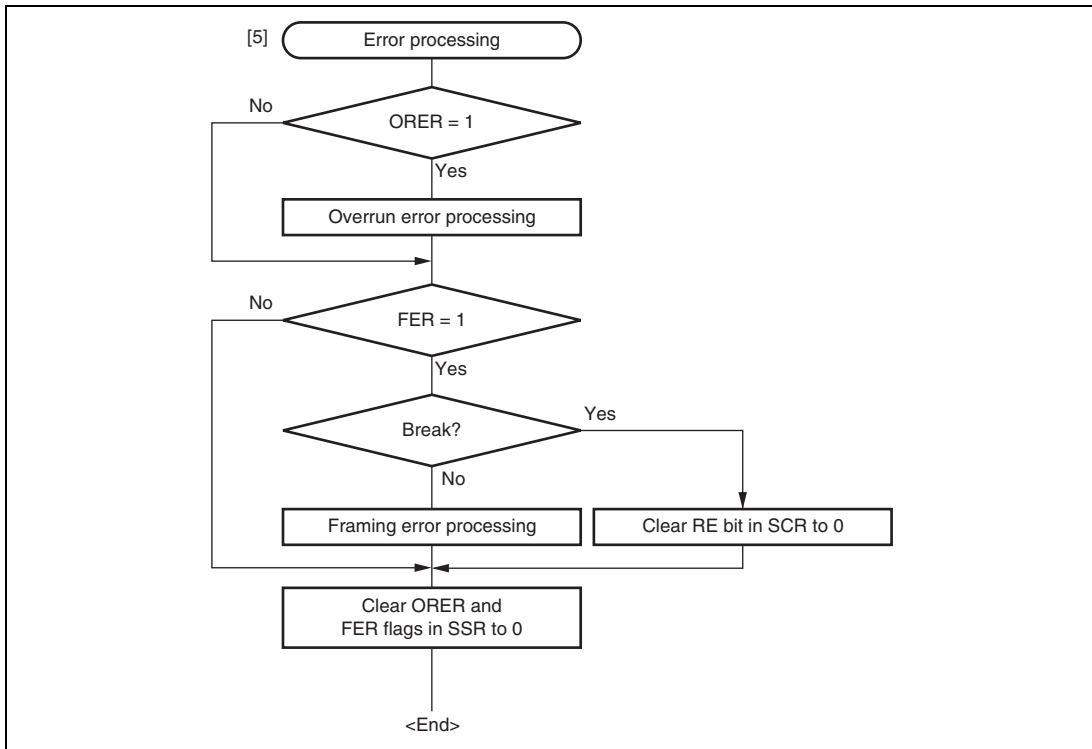

Figure 13.13 Sample Multiprocessor Serial Reception Flowchart (1)

**Figure 13.13 Sample Multiprocessor Serial Reception Flowchart (2)**

13.6 Operation in Clocked Synchronous Mode

Figure 13.14 shows the general format for clocked synchronous communication. In clocked synchronous mode, data is transmitted or received in synchronization with clock pulses. Data is transferred in 8-bit units. In clocked synchronous serial communication, data on the transmission line is output from one falling edge of the serial clock to the next. In clocked synchronous mode, the SCI receives data in synchronization with the rising edge of the serial clock. After 8-bit data is output, the transmission line holds the MSB state. In clocked synchronous mode, no parity or multiprocessor bit is added. Inside the SCI, the transmitter and receiver are independent units, enabling full-duplex communication by use of a common clock. Both the transmitter and the receiver also have a double-buffered structure, so that data can be read or written during transmission or reception, enabling continuous data transfer.

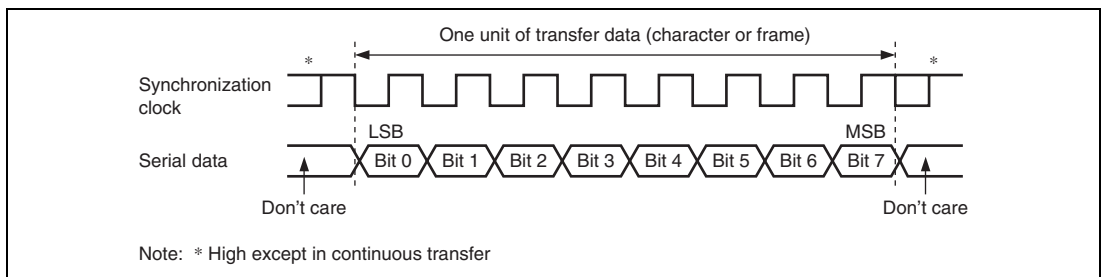

Figure 13.14 Data Format in Clocked Synchronous Communication (For LSB-First)

13.6.1 Clock

Either an internal clock generated by the on-chip baud rate generator or an external synchronization clock input at the SCK pin can be selected, according to the setting of CKE1 and CKE0 bits in SCR. When the SCI is operated on an internal clock, the serial clock is output from the SCK pin. Eight serial clock pulses are output in the transfer of one character, and when no transfer is performed, the clock is fixed high. However, during receive-only operation the synchronization clock is output until an overrun error occurs or the RE bit is cleared to 0. When receive operation in single-character units is desired, select an external clock as the clock source.

13.6.2 SCI Initialization (Clocked Synchronous Mode)

Before transmitting and receiving data, you should first clear the TE and RE bits in SCR to 0, then initialize the SCI as described in a sample flowchart in figure 13.15. When the operating mode, transfer format, etc., is changed, the TE and RE bits must be cleared to 0 before making the change using the following procedure. When the TE bit is cleared to 0, the TDRE flag is set to 1. Note that clearing the RE bit to 0 does not change the contents of the RDRF, PER, FER, and ORER flags, or the contents of RDR.

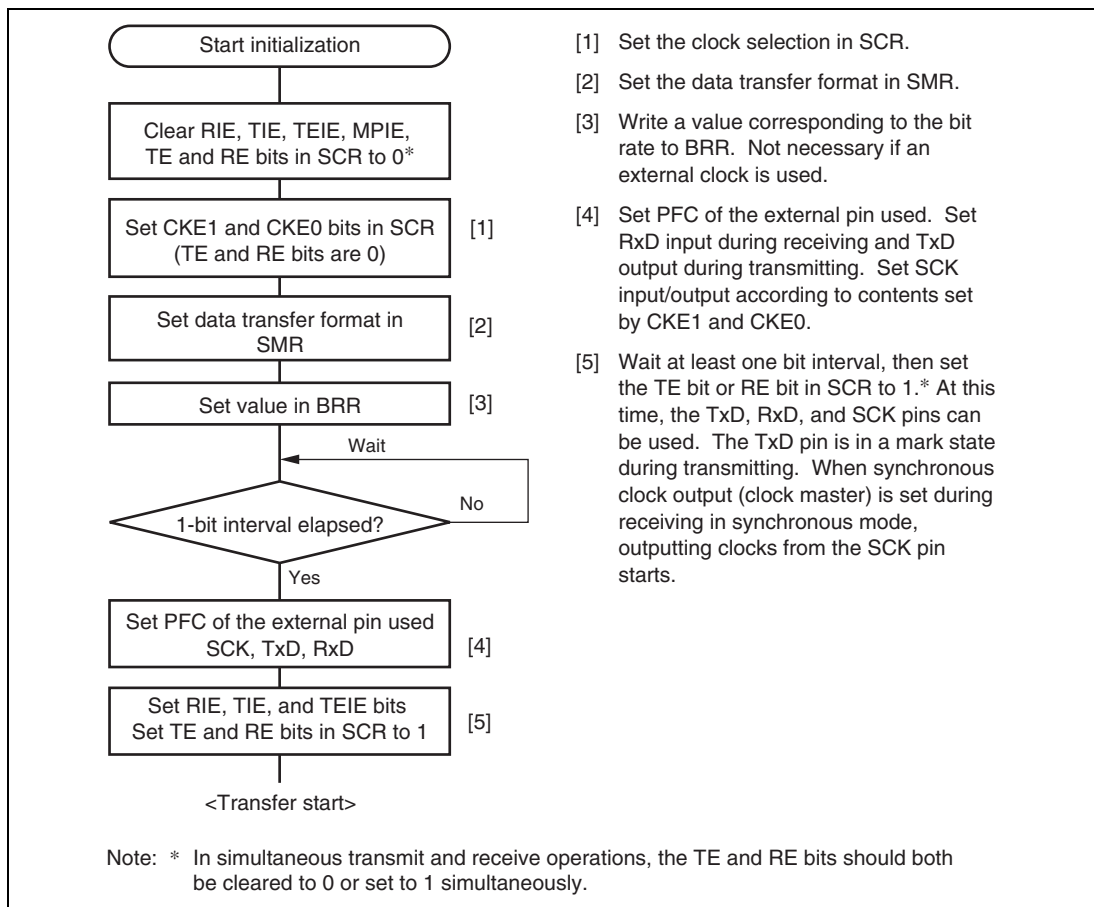

Figure 13.15 Sample SCI Initialization Flowchart

13.6.3 Serial Data Transmission (Clocked Synchronous Mode)

Figure 13.16 shows an example of SCI operation for transmission in clocked synchronous mode. In serial transmission, the SCI operates as described below.

1. The SCI monitors the TDRE flag in SSR, and if it is 0, recognizes that data has been written to TDR, and transfers the data from TDR to TSR.
2. After transferring data from TDR to TSR, the SCI sets the TDRE flag to 1 and starts transmission. If the TIE bit in SCR is set to 1 at this time, a transmit data empty (TXI) interrupt request is generated. Because the TXI interrupt routine writes the next transmit data to TDR before transmission of the current transmit data has finished, continuous transmission can be enabled.
3. 8-bit data is sent from the TxD pin synchronized with the output clock when output clock mode has been specified and synchronized with the input clock when use of an external clock has been specified.
4. The SCI checks the TDRE flag at the timing for sending the MSB (bit 7).
5. If the TDRE flag is cleared to 0, data is transferred from TDR to TSR, and serial transmission of the next frame is started.
6. If the TDRE flag is set to 1, the TEND flag in SSR is set to 1, and the TxD pin maintains the output state of the last bit. If the TEIE bit in SCR is set to 1 at this time, a TEI interrupt request is generated. The SCK pin is fixed high.

Figure 13.17 shows a sample flowchart for serial data transmission. Even if the TDRE flag is cleared to 0, transmission will not start while a receive error flag (ORER, FER, or PER) is set to 1. Make sure to clear the receive error flags to 0 before starting transmission. Note that clearing the RE bit to 0 does not clear the receive error flags.

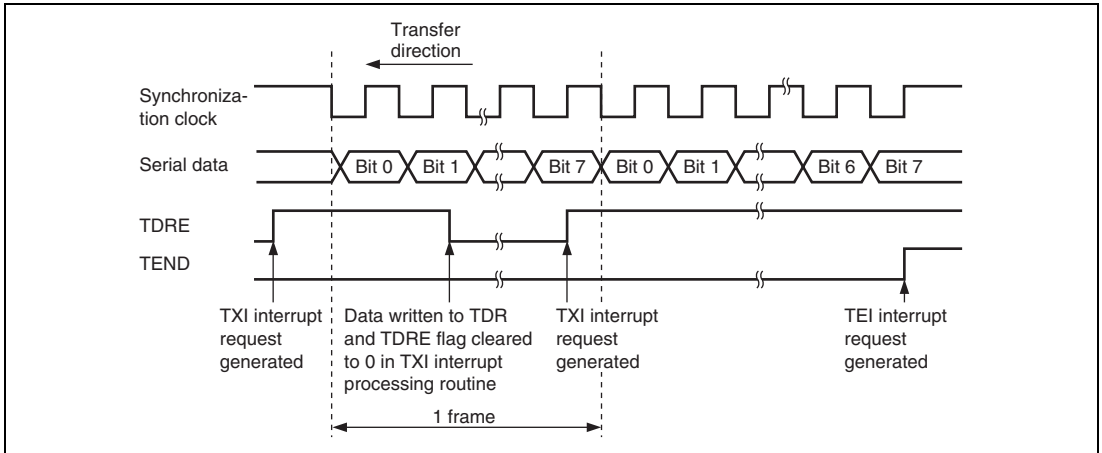

Figure 13.16 Sample SCI Transmission Operation in Clocked Synchronous Mode

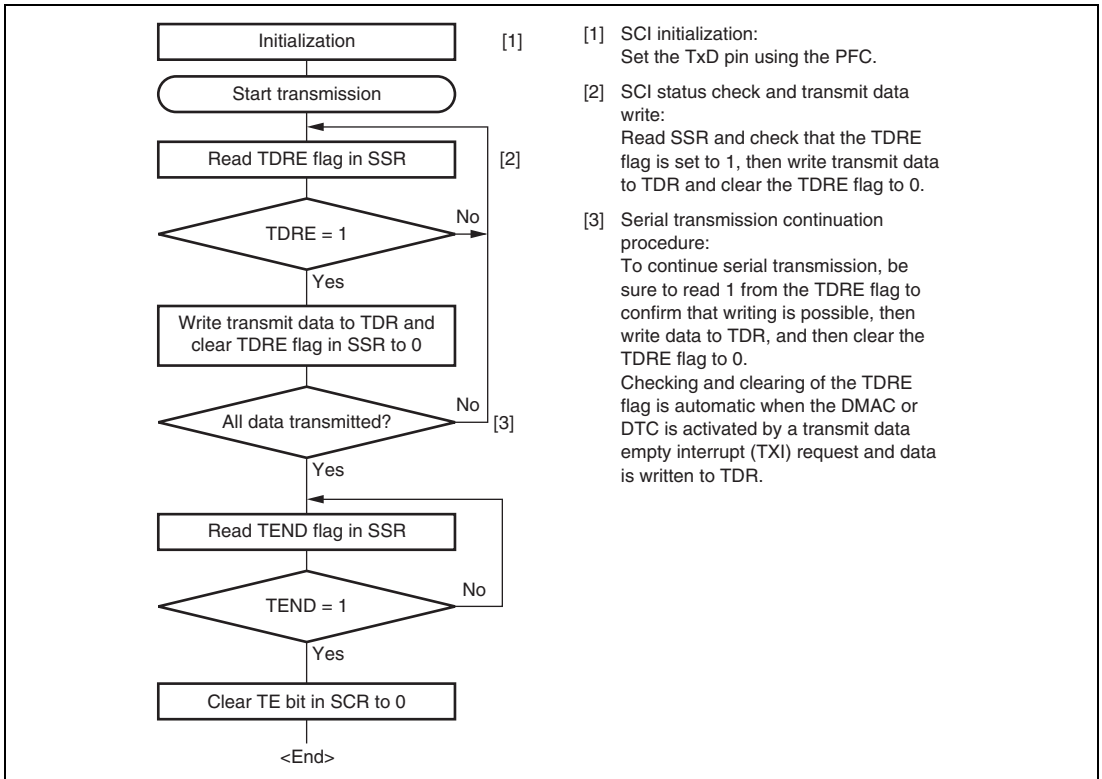

Figure 13.17 Sample Serial Transmission Flowchart

13.6.4 Serial Data Reception (Clocked Synchronous Mode)

Figure 13.18 shows an example of SCI operation for reception in clocked synchronous mode. In serial reception, the SCI operates as described below.

1. The SCI performs internal initialization in synchronization with a synchronization clock input or output, starts receiving data, and stores the received data in RSR.
2. If an overrun error (when reception of the next data is completed while the RDRF flag is still set to 1) occurs, the ORER bit in SSR is set to 1. If the RIE bit in SCR is set to 1 at this time, an ERI interrupt request is generated. Receive data is not transferred to RDR. The RDRF flag remains to be set to 1.
3. If reception finishes successfully, the RDRF bit in SSR is set to 1, and receive data is transferred to RDR. If the RIE bit in SCR is set to 1 at this time, an RXI interrupt request is generated. Because the RXI interrupt processing routine reads the receive data transferred to RDR before reception of the next receive data has finished, continuous reception can be enabled.

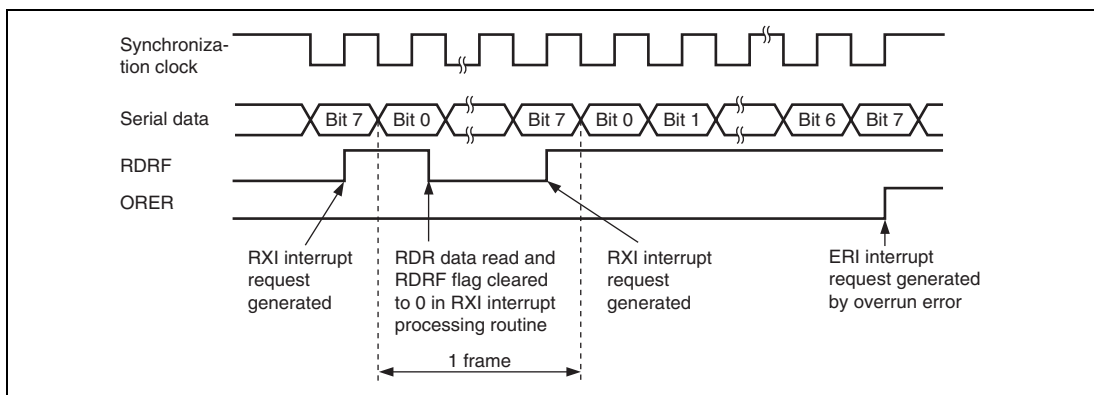

Figure 13.18 Example of SCI Operation in Reception

Reception cannot be resumed while a receive error flag is set to 1. Accordingly, clear the ORER, FER, PER, and RDRF bits to 0 before resuming reception. Figure 13.19 shows a sample flowchart for serial data reception.

An overrun error occurs or synchronous clocks are output until the RE bit is cleared to 0 when an internal clock is selected and only receive operation is possible. When reception will be carried out in a unit of one frame, be sure to carry out a dummy transmission with only one frame by the simultaneous transmit and receive operations at the same time.

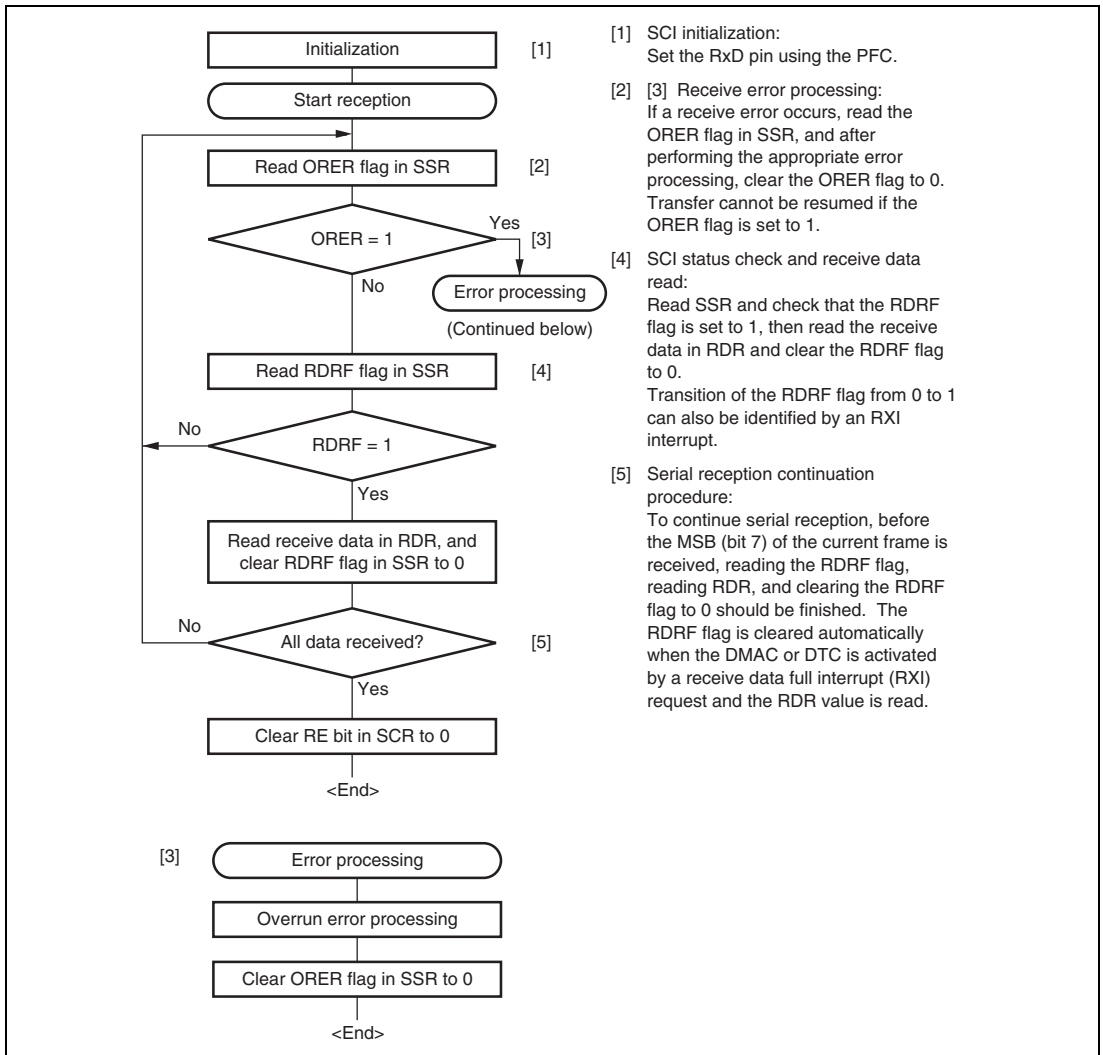
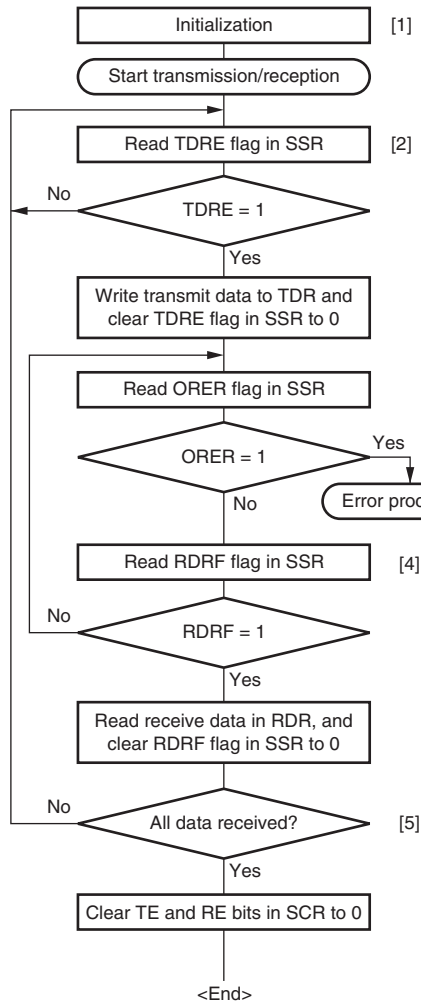

Figure 13.19 Sample Serial Reception Flowchart

13.6.5 Simultaneous Serial Data Transmission and Reception (Clocked Synchronous Mode)

Figure 13.20 shows a sample flowchart for simultaneous serial transmit and receive operations. The following procedure should be used for simultaneous serial data transmit and receive operations after the SCI initialization. To switch from transmit mode to simultaneous transmit and receive mode, after checking that the SCI has finished transmission and the TDRE and TEND flags are set to 1, clear TE to 0. Then simultaneously set TE and RE to 1 with a single instruction. To switch from receive mode to simultaneous transmit and receive mode, after checking that the SCI has finished reception, clear RE to 0. Then after checking that the RDRF and receive error flags (ORER, FER, and PER) are cleared to 0, simultaneously set TE and RE to 1 with a single instruction.



- [1] SCI initialization:
Set the TxD and RxD pins using the PFC.
- [2] SCI status check and transmit data write:
Read SSR and check that the TDRE flag is set to 1, then write transmit data to TDR and clear the TDRE flag to 0. Transition of the TDRE flag from 0 to 1 can also be identified by a TXI interrupt.
- [3] Receive error processing:
If a receive error occurs, read the ORER flag in SSR, and after performing the appropriate error processing, clear the ORER flag to 0. Transmission/reception cannot be resumed if the ORER flag is set to 1.
- [4] SCI status check and receive data read:
Read SSR and check that the RDRF flag is set to 1, then read the receive data in RDR and clear the RDRF flag to 0. Transition of the RDRF flag from 0 to 1 can also be identified by an RXI interrupt.
- [5] Serial transmission/reception continuation procedure:
To continue serial transmission/reception, before the MSB (bit 7) of the current frame is received, finish reading the RDRF flag, reading RDR, and clearing the RDRF flag to 0. Also, before the MSB (bit 7) of the current frame is transmitted, read 1 from the TDRE flag to confirm that writing is possible. Then write data to TDR and clear the TDRE flag to 0. Checking and clearing of the TDRE flag is automatic when the DMAC or DTC is activated by a transmit data empty interrupt (TXI) request and data is written to TDR. Also, the RDRF flag is cleared automatically when the DMAC or DTC is activated by a receive data full interrupt (RXI) request and the RDR value is read.

Note: When switching from transmit or receive operation to simultaneous transmit and receive operations, first clear the TE bit and RE bit to 0, then set both these bits to 1 simultaneously.

Figure 13.20 Sample Flowchart of Simultaneous Serial Transmit and Receive Operations

13.7 Smart Card Interface

The SCI supports an IC card (smart card) interface that conforms to ISO/IEC 7816-3 (Identification Card) as an extension function for the serial communication interface. Switching to smart card interface mode is carried out by means of a register setting.

13.7.1 Pin Connection Example

Figure 13.21 shows an example of connection with the smart card. In communication with an IC card, as both transmission and reception are carried out on a single data transmission line, but the TxD pin is always fixed to output. Note that the following controls are needed to avoid signal collision: (1) control of data directions between TXD and I/O in the external circuit and (2) setting of the TXD pin to an input port except in transmission. Similarly, since the RxD pin is always fixed to input, connect a pull-up resistor to avoid the open state.

When the clock generated by the SCI is supplied to an IC card, the SCK pin output is input to the CLK pin of the IC card. If an internal clock is used in an IC card, the connection between the SCK and CLK pins is unnecessary. This LSI port output can be used as the reset signal. Connection between the power supply and ground pins is also necessary.

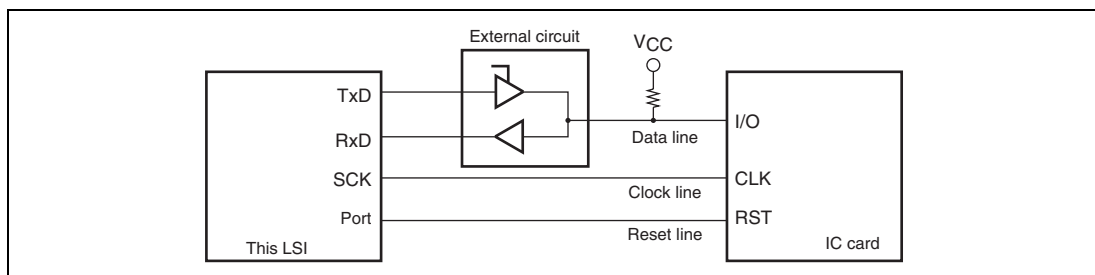

Figure 13.21 Example of Pin Connections for Smart Card Interface

13.7.2 Data Format (Except for Block Transfer Mode)

Figure 13.22 shows the transfer data format in smart card interface mode.

- One frame consists of 8-bit data plus a parity bit in asynchronous mode.
- In transmission, a guard time of at least 2 etu (Elementary time unit: the time for transfer of one bit) is left between the end of the parity bit and the start of the next frame.
- If a parity error is detected during reception, a low error signal level is output for one etu period, 10.5 etu after the start bit.
- If an error signal is sampled during transmission, the same data is retransmitted automatically after a delay of 2 etu or longer.

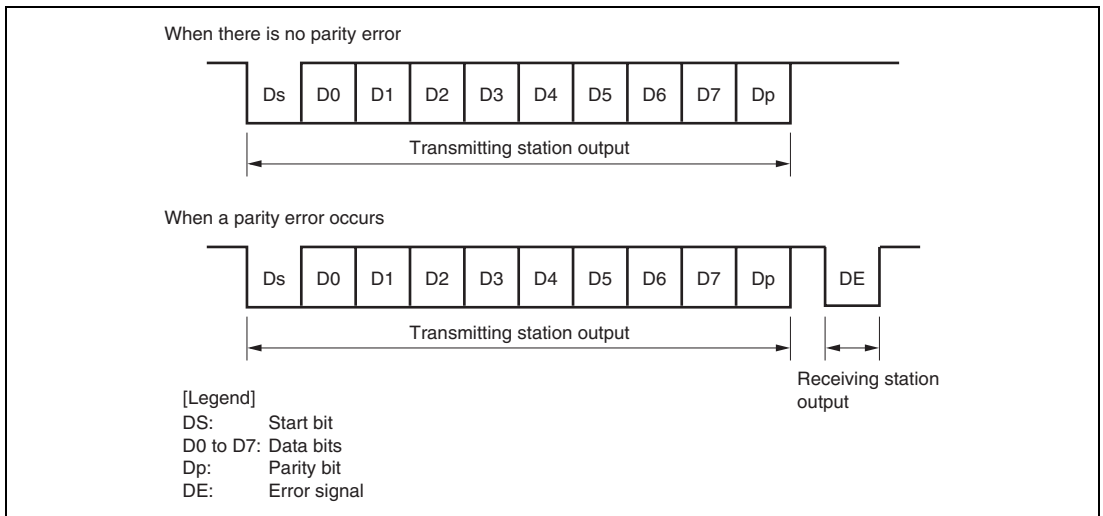

Figure 13.22 Normal Smart Card Interface Data Format

Data transfer with other types of IC cards (direct convention and inverse convention) should be performed as described in the following.

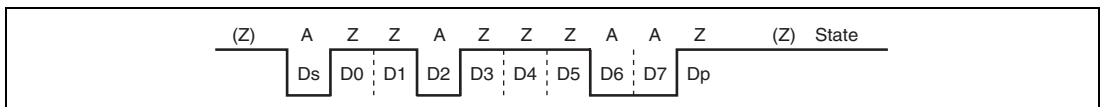

Figure 13.23 Direct Convention (DIR = SINV = $\overline{O/E}$ = 0)

With the direction convention type IC and the above sample start character, the logic 1 level corresponds to state Z and the logic 0 level to state A, and transfer is performed in LSB-first order. The above start character data is H'3B. For the direct convention type, clear the DIR and SINV

bits in SDCR to 0. According to smart card regulations, clear the O/\bar{E} bit in SMR to 0 to select even parity mode.

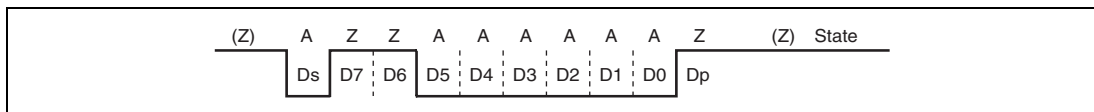

Figure 13.24 Inverse Convention (DIR = SINV = $O/\bar{E} = 1$)

With the inverse convention type, the logic 1 level corresponds to state A and the logic 0 level to state Z, and transfer is performed in MSB-first order. The above start character data is H'3F. For the inverse convention type, set the DIR and SINV bits in SDCR to 1. According to smart card regulations, even parity mode is the logic 0 level of the parity bit, and corresponds to state Z. In this LSI, the SINV bit inverts only data bits D0 to D7. Therefore, set the O/\bar{E} bit in SMR to 1 to invert the parity bit for both transmission and reception.

13.7.3 Block Transfer Mode

Operation in block transfer mode is the same as that in the normal smart card interface mode, except for the following points.

- In reception, though the parity check is performed, no error signal is output even if an error is detected. However, the PER bit in SSR is set to 1 and must be cleared before receiving the parity bit of the next frame.
- In transmission, a guard time of at least 1 etu is left between the end of the parity bit and the start of the next frame.
- In transmission, because retransmission is not performed, the TEND flag is set to 1, 11.5 etu after transmission start.
- As with the normal smart card interface, the ERS flag indicates the error signal status, but since error signal transfer is not performed, this flag is always cleared to 0.

13.7.4 Receive Data Sampling Timing and Reception Margin

In smart card interface mode an internal clock generated by the on-chip baud rate generator can only be used as a transmit/receive clock. In this mode, the SCI operates on a basic clock with a frequency of 32, 64, 372, or 256 times the bit rate (fixed to 16 times in normal asynchronous mode) as determined by bits BCP1 and BCP0. In reception, the SCI samples the falling edge of the start bit using the basic clock, and performs internal synchronization. As shown in figure 13.25, by sampling receive data at the rising edge of the 16th, 32nd, 186th, or 128th pulse of the basic clock, data can be latched at the middle of the bit. The reception margin is given by the following formula.

$$M = \left| \left(0.5 - \frac{1}{2N} \right) - (L - 0.5) F - \frac{|D - 0.5|}{N} (1 + F) \right| \times 100\%$$

Where M: Reception margin (%)

N: Ratio of bit rate to clock (N = 32, 64, 372, and 256)

D: Clock duty (D = 0 to 1.0)

L: Frame length (L = 10)

F: Absolute value of clock frequency deviation

Assuming values of F = 0, D = 0.5, and N = 372 in the above formula, the reception margin formula is as follows.

$$\begin{aligned} M &= (0.5 - 1/2 \times 372) \times 100\% \\ &= 49.866\% \end{aligned}$$

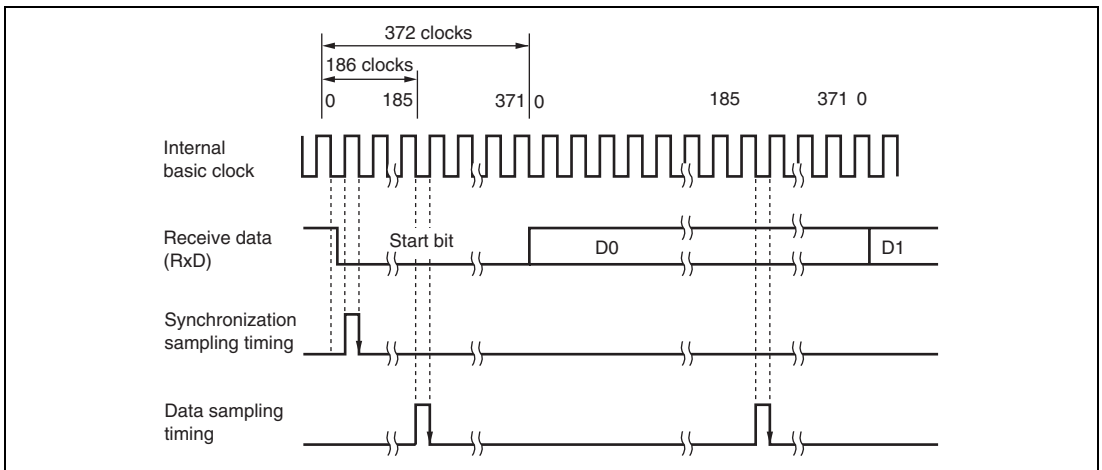

**Figure 13.25 Receive Data Sampling Timing in Smart Card Interface Mode
(Using Clock of 372 Times Bit Rate)**

13.7.5 Initialization

Before transmitting and receiving data, initialize the SCI as described below. Initialization is also necessary when switching from transmit mode to receive mode, or vice versa.

1. Clear the RIE, TIE, TEIE, MPIE, TE, and RE bits in SCR to 0.
2. Clear the error flags ERS, PER, and ORER in SSR to 0.
3. Set the GM, BLK, O/\bar{E} , BCP1, BCP0, CKS1, and CKS0 bits in SMR. Set the PE bit to 1.
4. Set the SMIF, DIR, and SINV bits in SDCR.
5. Set the value corresponding to the bit rate to BRR.
6. Set the CKE1 and CKE0 bits in SCR. Clear the TIE, RIE, TE, RE, MPIE, and TEIE bits to 0.
7. Wait at least one bit interval, then set the TIE and RIE bits in SCR.
8. Make the pin function settings for the external pins (SCK, TxD, and RxD).
9. Set the TE and RE bits in SCR. Except for self diagnosis, do not set the TE bit and RE bit at the same time.

To switch from receive mode to transmit mode, after checking that the SCI has finished reception, initialize the SCI, and clear the RE bit to 0 and set the TE bit to 1. Whether the SCI has finished reception or not can be checked with the RDRF, PER, or ORER flag. To switch from transmit mode to receive mode, after checking that the SCI has finished transmission, initialize the SCI, and clear the TE bit to 0 and set the RE bit to 1. Whether the SCI has finished transmission or not can be checked with the TEND flag.

13.7.6 Serial Data Transmission (Except for Block Transfer Mode)

As data transmission in smart card interface mode involves error signal sampling and retransmission processing, the operations are different from those in normal serial communication interface mode (except for block transfer mode). Figure 13.26 illustrates the retransfer operation when the SCI is in transmit mode.

1. If an error signal is sampled from the receiving end after transmission of one frame is completed, the ERS bit in SSR is set to 1. If the RIE bit in SCR is set at this time, an ERI interrupt request is generated. The ERS bit in SSR should be cleared to 0 by the time the next parity bit is sampled.
2. The TEND flag in SSR is not set for a frame in which an error signal is received. Data is retransferred from TDR to TSR, and retransmitted automatically.
3. If an error signal is not sent back from the receiving end, the ERS bit in SSR is not set. Transmission of one frame, including a retransfer, is decided to have been completed, and the TEND flag in SSR is set to 1. If the TIE bit in SCR is set at this time, a TXI interrupt request is generated. Writing transmit data to TDR transmits the next data.

Figure 13.28 shows an example of a flowchart for transmission.

A sequence of transmit operations can be performed automatically by specifying the DMAC or DTC to be activated with a TXI interrupt source.

In a transmit operation, the TDRE flag is set to 1 at the same time as the TEND flag in SSR is set, and a TXI interrupt request will be generated if the TIE bit in SCR has been set to 1.

If the TXI request is designated beforehand as a DMAC or DTC activation source, the DMAC or DTC will be activated by the TXI request, and transfer of the transmit data will be carried out. The TDRE and TEND flags are automatically cleared to 0 when data is transferred by the DMAC or DTC.

In the event of an error, the SCI retransmits the same data automatically. During this period, the TEND flag remains cleared to 0 and the DMAC or DTC is not activated. Therefore, the SCI and DMAC or DTC will automatically transmit the specified number of bytes in the event of an error, including retransmission. However, the ERS flag is not cleared automatically when an error occurs, and so the RIE bit should be set to 1 beforehand so that an ERI interrupt request will be generated in the event of an error, and the ERS flag will be cleared.

When performing transfer using the DMAC or DTC, it is essential to set and enable the DMAC or DTC before carrying out SCI setting.

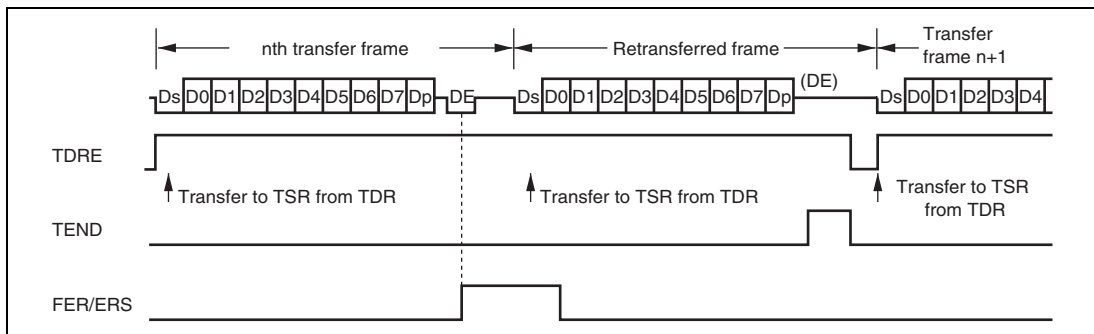

Figure 13.26 Retransfer Operation in SCI Transmit Mode

The timing for setting the TEND flag depends on the value of the GM bit in SMR. The TEND flag generation timing is shown in figure 13.27.

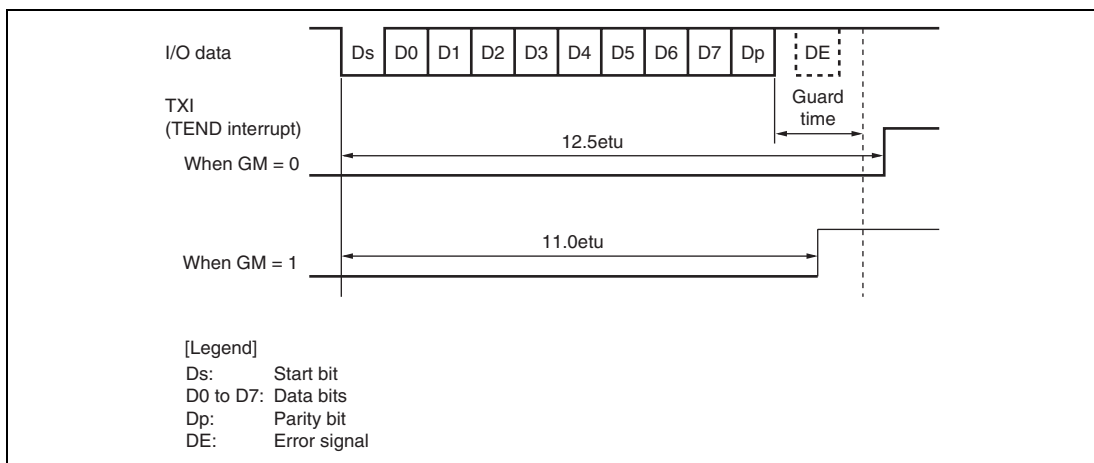

Figure 13.27 TEND Flag Generation Timing in Transmit Operation

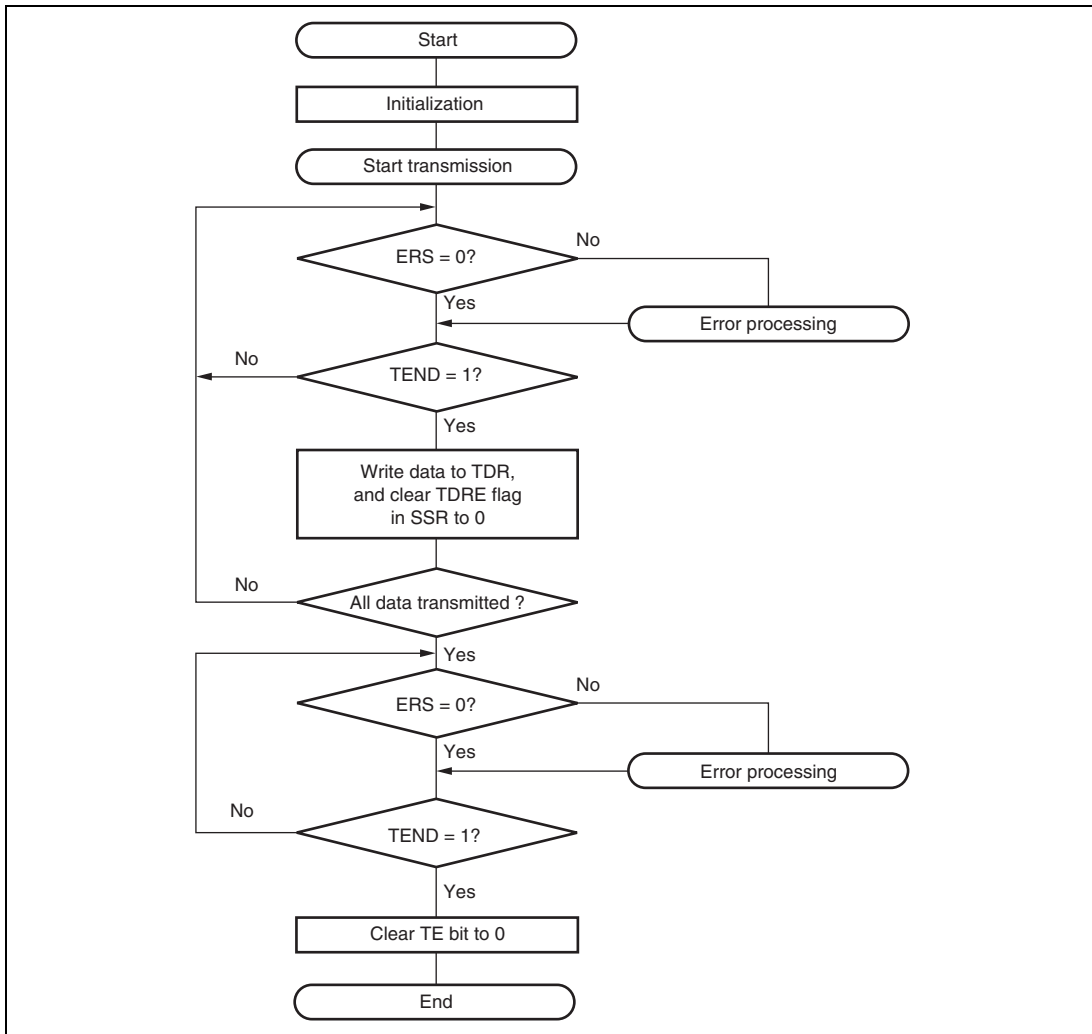

Figure 13.28 Example of Transmit Processing Flow

In smart card interface mode, data reception should be performed in block transfer mode. For details, refer to section 13.4, Operation in Asynchronous Mode.

13.7.7 Clock Output Control

When the GM bit in SMR is set to 1, the clock output level can be fixed with the CKE1 and CKE0 bits in SCR. At this time, the minimum clock pulse width can be specified.

Figure 13.29 shows the timing for fixing the clock output level. In this example, the GM bit is set to 1, the CKE1 bit is cleared to 0, and the CKE0 bit is controlled.

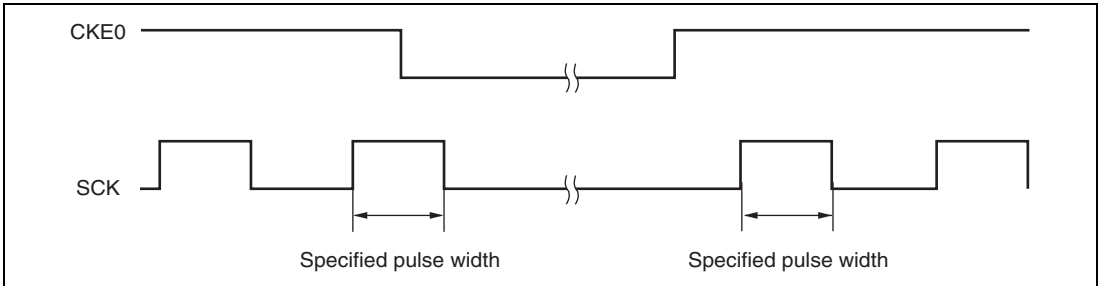

Figure 13.29 Timing for Fixing Clock Output Level

13.8 Interrupt Sources

13.8.1 Interrupts in Normal Serial Communication Interface Mode

Table 13.12 shows the interrupt sources in normal serial communication interface mode. A different interrupt vector is assigned to each interrupt source, and individual interrupt sources can be enabled or disabled using the enable bits in SCR.

When the TDRE flag in SSR is set to 1, a TXI interrupt request is generated. When the TEND flag in SSR is set to 1, a TEI interrupt request is generated. A TXI interrupt request can activate the DMAC or DTC to perform data transfer. The TDRE flag is cleared to 0 automatically when data transfer is performed by the DMAC or DTC.

When the RDRF flag in SSR is set to 1, an RXI interrupt request is generated. When the ORER, PER, or FER flag in SSR is set to 1, an ERI interrupt request is generated. An RXI interrupt request can activate the DMAC or DTC to perform data transfer. The RDRF flag is cleared to 0 automatically when data transfer is performed by the DMAC or DTC.

A TEI interrupt is generated when the TEND flag is set to 1 while the TEIE bit is set to 1. If a TEI interrupt and a TXI interrupt are generated simultaneously, the TXI interrupt has priority for acceptance. However, note that if the TDRE and TEND flags are cleared simultaneously by the TXI interrupt routine, the SCI cannot branch to the TEI interrupt routine later.

Table 13.12 Interrupt Sources in Serial Communication Interface Mode

| Channel | Name | Interrupt Source | Interrupt Flag | DMAC or DTC Activation |
|----------------|-------------|-------------------------|-----------------------|-------------------------------|
| 0 | ERI_0 | Receive error | ORER, FER, PER | Not possible |
| | RXI_0 | Receive data full | RDRF | Possible |
| | TXI_0 | Transmit data empty | TDRE | Possible |
| | TEI_0 | Transmission end | TEND | Not possible |
| 1 | ERI_1 | Receive error | ORER, FER, PER | Not possible |
| | RXI_1 | Receive data full | RDRF | Possible |
| | TXI_1 | Transmit data empty | TDRE | Possible |
| | TEI_1 | Transmission end | TEND | Not possible |
| 2 | ERI_2 | Receive error | ORER, FER, PER | Not possible |
| | RXI_2 | Receive data full | RDRF | Possible |
| | TXI_2 | Transmit data empty | TDRE | Possible |
| | TEI_2 | Transmission end | TEND | Not possible |
| 3 | ERI_3 | Receive error | ORER, FER, PER | Not possible |
| | RXI_3 | Receive data full | RDRF | Possible |
| | TXI_3 | Transmit data empty | TDRE | Possible |
| | TEI_3 | Transmission end | TEND | Not possible |

13.8.2 Interrupts in Smart Card Interface Mode

Table 13.13 shows the interrupt sources in smart card interface mode. The transmit end interrupt (TEI) request cannot be used in this mode.

Note: In block transfer mode, refer to section 13.8.1, Interrupts in Normal Serial Communication Interface Mode.

Table 13.13 Interrupt Sources in Smart Card Interface Mode

| Channel | Name | Interrupt Source | Interrupt Flag | DMAC or DTC Activation |
|---------|-------|---------------------------------------|----------------|------------------------|
| 0 | ERI_0 | Receive error, error signal detection | ORER, PER, ERS | Not possible |
| | RXI_0 | Receive data full | RDRF | Possible |
| | TXI_0 | Transmit data empty | TEND | Possible |
| 1 | ERI_1 | Receive error, error signal detection | ORER, PER, ERS | Not possible |
| | RXI_1 | Receive data full | RDRF | Possible |
| | TXI_1 | Transmit data empty | TEND | Possible |
| 2 | ERI_2 | Receive error, error signal detection | ORER, PER, ERS | Not possible |
| | RXI_2 | Receive data full | RDRF | Possible |
| | TXI_2 | Transmit data empty | TEND | Possible |
| 3 | ERI_3 | Receive error, error signal detection | ORER, PER, ERS | Not possible |
| | RXI_3 | Receive data full | RDRF | Possible |
| | TXI_3 | Transmit data empty | TEND | Possible |

13.9 Usage Notes

13.9.1 TDR Write and TDRE Flag

The TDRE bit in the serial status register (SSR) is a status flag indicating transferring of transmit data from TDR into TSR. The SCI sets the TDRE bit to 1 when it transfers data from TDR to TSR.

Data can be written to TDR regardless of the TDRE bit status.

If new data is written in TDR when TDRE is 0, however, the old data stored in TDR will be lost because the data has not yet been transferred to TSR. Before writing transmit data to TDR, be sure to check that the TDRE bit is set to 1.

13.9.2 Module Standby Mode Setting

SCI operation can be disabled or enabled using the module standby control register. The initial setting is for SCI operation to be halted. Register access is enabled by clearing module standby mode. For details, refer to section 24, Power-Down Modes.

13.9.3 Break Detection and Processing (Asynchronous Mode Only)

When framing error detection is performed, a break can be detected by reading the RxD pin value directly. In a break, the input from the RxD pin becomes all 0s, and so the FER flag is set, and the PER flag may also be set. Note that, since the SCI continues the receive operation after receiving a break, even if the FER flag is cleared to 0, it will be set to 1 again.

13.9.4 Sending Break Signal (Asynchronous Mode Only)

The TxD pin becomes of the I/O port general I/O pin with the I/O direction and level determined by the port data register (DR) and the port I/O register (IOR) of the pin function controller (PFC). These conditions allow break signals to be sent.

The DR value is substituted for the marking status until the PFC is set. Consequently, the output port is set to initially output a 1.

To send a break in serial transmission, first clear the DR to 0, then establish the TxD pin as an output port using the PFC.

When the TE bit is cleared to 0, the transmission section is initialized regardless of the present transmission status.

13.9.5 Receive Error Flags and Transmit Operations (Clocked Synchronous Mode Only)

Transmission cannot be started when a receive error flag (ORER, PER, or FER) is set to 1, even if the TDRE flag is cleared to 0. Be sure to clear the receive error flags to 0 before starting transmission. Note also that receive error flags cannot be cleared to 0 even if the RE bit is cleared to 0.

13.9.6 Notes on DMAC and DTC Use

1. When using an external clock source for the serial clock, update TDR with the DMAC or the DTC, and then after the elapse of five peripheral clocks ($P\phi$) or more, input a transmit clock. If a transmit clock is input in the first four $P\phi$ clocks after TDR is written, an error may occur (figure 13.30).
2. Before reading the receive data register (RDR) with the DMAC or the DTC, select the receive-data-full (RXI) interrupt of the SCI as a start-up source.

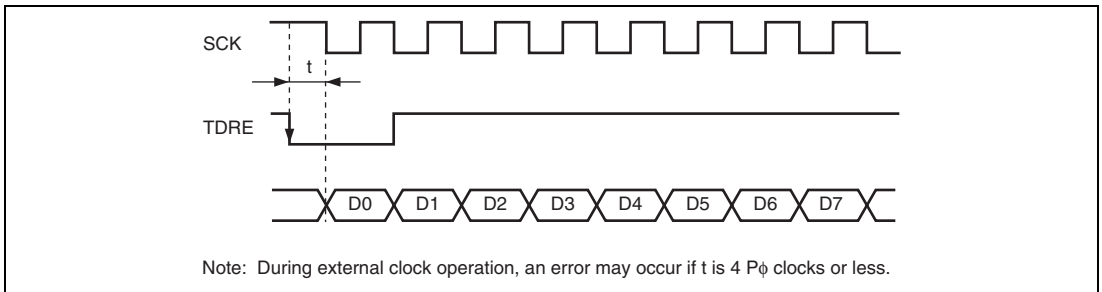

Figure 13.30 Example of Clocked Synchronous Transmission with DMAC/DTC

13.9.7 Notes on Clocked Synchronous External Clock Mode

1. Set $TE = RE = 1$ only when external clock SCK is 1.
2. Do not set $TE = RE = 1$ until at least four $P\phi$ clocks after external clock SCK has changed from 0 to 1.
3. When receiving, RDRF is 1 when RE is cleared to 0 after 2.5 to 3.5 $P\phi$ clocks from the rising edge of the RxD D7 bit SCK input, but copying to RDR is not possible.

13.9.8 Note on Clocked Synchronous Internal Clock Mode

When receiving, RDRF is 1 when RE is cleared to 0 after 1.5 P ϕ clocks from the rising edge of the RxD D7 bit SCK output, but copying to RDR is not possible.

Section 14 I²C Bus Interface (IIC) Option

The I²C bus interface is an optional feature. When using this optional feature, pay attention to the following point:

- A “W” is added to the product-type name of a mask-ROM product which includes an optional feature.
-

This LSI incorporates a single-channel I²C bus interface. The I²C bus interface conforms to the Philips I²C bus (Inter-IC bus) interface system and provides a subset of the functions. Note, however, that the configuration of the registers that control the I²C bus differs on some points from that of Phillips’.

Data transfer is carried out by the data line (SDA0) and clock line (SCL0). This makes the interface efficient in terms of the use of area for connectors and printed circuits.

14.1 Features

- Selection of addressing or non-addressing format
I²C bus format: addressing format with an acknowledge bit, master and slave operation
Synchronous serial format: non-addressing format without an acknowledge bit, and with master operation only
- This I²C bus format complies with the I²C bus interface advocated by Phillips.
- In the I²C bus format, two slave addresses are specifiable for a single device.
- Automatic creation of start and stop conditions in master mode of the I²C bus format
- Selectable acknowledge output level during reception in the I²C bus format
- Automatic loading of the acknowledge bit is available during transmission in the I²C bus format.
- A wait function is available in the I²C bus format in the master mode.
After all data other than the acknowledge bit has been transferred, the system can be placed in the wait state by setting SCL low. The wait state can be cancelled by clearing the interrupt flag to 0.
- A wait function is available in the I²C bus format.
After all data other than the acknowledge bit has been transferred, a request to enter the wait state can be issued by setting SCL low. The request to enter the wait state is cleared when the next transfer becomes possible.
- Interrupt sources
Data transfer end (including when a transition to transmit mode is made in the I²C bus format, when data in ICDR is transferred, or during a wait state)
Address match: when any slave address matches or the general call address is received in slave receive mode of the I²C bus format (including address reception after loss in master contention)
Loss of arbitration
Start condition detection (in master mode)
Stop condition detection (in slave mode)
- Sixteen variants of the internal clock are selectable in the master mode.
- Direct bus drive (SCL/SDA pin)
Pins SCL0 and SDA0 function as NMOS open-drain output.

Figure 14.1 is a block diagram of the I²C bus interface. Figure 14.2 shows an example of the connection of I²C bus interfaces. Since the I/O pins are driven only by the NMOS transistor, they operate in the same way as pins driven by an open-drain NMOS transistor. The voltage that can be applied to the I/O pins depends on the supply voltage of the LSI.

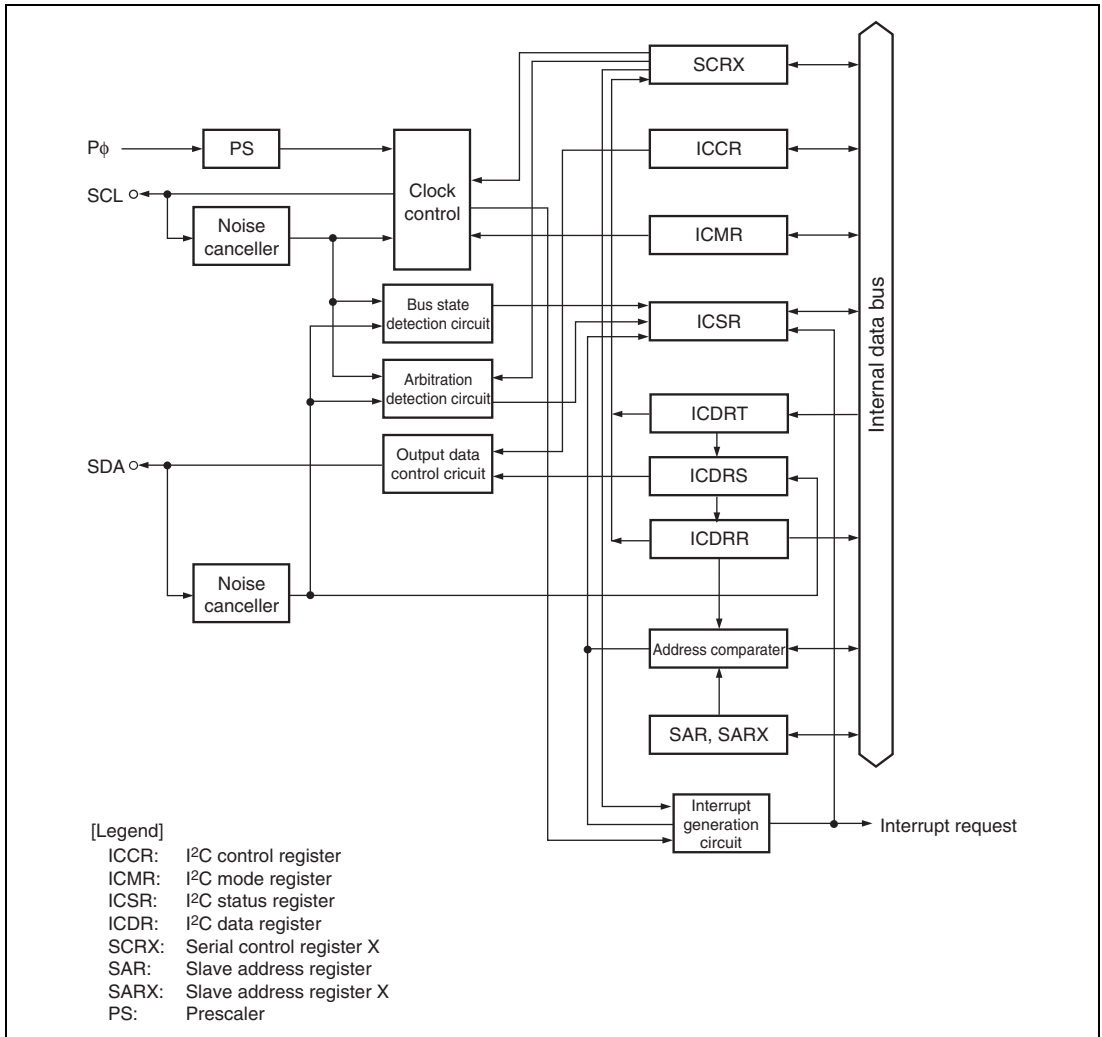
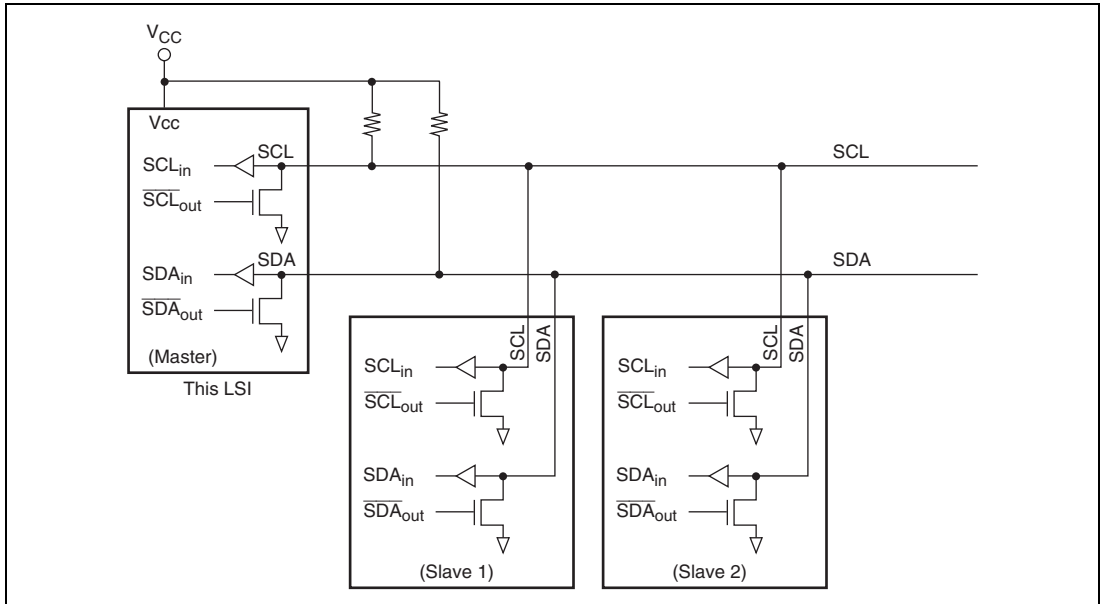

Figure 14.1 A Block Diagram of the I²C Bus Interface



**Figure 14.2 Example of the Connection of I²C Bus Interfaces
(This LSI Is the Master Device)**

14.2 Input/Output Pins

The I/O pins of the I²C bus interface are listed in table 14.1.

Table 14.1 Pin Configuration

| Channel | Pin Name* | I/O | Function |
|---------|-----------|-----|----------------------|
| 0 | SCL0 | I/O | Serial clock I/O pin |
| | SDA0 | I/O | Serial data I/O pin |

Note: * In this manual, these pin names are abbreviated to SCL and SDA, respectively.

14.3 Description of Registers

The I²C bus interface includes the following registers for each channel. For the addresses of these registers and the states of the registers in each state of processing, refer to section 25, List of Registers. Registers ICDR and SARX and registers ICMR and SAR are allocated to the same addresses, and accessible registers differ depending on the state of ICE bit in ICCR. When the ICE bit is 0, SAR and SARX can be accessed, and when the ICE bit is 1, ICMR and ICDR can be accessed.

- I²C bus control register (ICCR)
- I²C bus status register (ICSR)
- I²C bus data register (ICDR)
- I²C bus mode register (ICMR)
- Slave-address register (SAR)
- Second slave-address register (SARX)
- Serial control register X (SCRX)

14.3.1 I²C Bus Data Register (ICDR)

ICDR is an 8-bit readable/writable register that holds the data for transmission during transmission, and holds the received data during reception. Internally, ICDR consists of a shift register (ICDRS), receive buffer (ICDRR), and transmission buffer (ICDRT).

Data is automatically transferred between these three registers according to the bus state; this affects the states of flags, such as the ICDRF flag in SCRX and the internal flag ICDRE.

In master transmit mode of the I²C bus format, writing transmit data to ICDR should be performed after start condition is detected. When the start condition is detected, previous write data is ignored. In slave transmit mode, writing should be performed after the slave addresses match and the TRS bit is automatically changed to 1.

When I²C is in transmit mode (TRS = 1) and the next I²C transmit data is in ICDRT (the ICDRE flag is 0), data is transferred automatically from ICDRT to ICDRS after successful transmission of one frame of data using ICDRS. When the ICDRE flag is 1 and the next transmit data writing is waited, data is transferred automatically from ICDRT to ICDRS by writing to ICDR. In receive mode (TRS = 0), no data is transferred from ICDRT to ICDRS. Note that data should not be written to ICDR in receive mode.

Reading receive data from ICDR is performed after data is transferred from ICDRS to ICDRR.

When I²C is in receive mode and no previous data remains in ICDRR (the ICDRF flag is 0), data is transferred automatically from ICDRS to ICDRR, following reception of one frame of data using ICDRS. When additional data is received while the ICDRF flag is 1, data is transferred automatically from ICDRS to ICDRR by reading from ICDR. In transmit mode, no data is transferred from ICDRS to ICDRR. Always set I²C to receive mode before reading from ICDR.

When, excluding the acknowledge bit, there are fewer than 8 bits in one frame, the alignment of the data for transmission and of received data varies according to the setting of the MLS bit in ICMR. Data for transmission should span the selected number of bits from the MSB when MLS = 0. When MLS is 1, the data should span the selected number of bits from the LSB. Received data is read from the LSB when MLS is 0 and from the MSB when MLS is 1.

ICDR is only accessible when the ICE bit in ICCR is set to 1. The ICDR is undefined at reset.

14.3.2 Slave-Address Register (SAR)

SAR sets the transfer format and stores the slave address. In slave mode of the I²C bus format, if the FS bit is set to 0 and the upper seven bits of SAR match the upper seven bits of the first frame received after a start condition, this module operates as the slave device specified by the master device. SAR can be accessed only when the ICE bit in ICCR is set to 0.

| Bit | Bit Name | Initial Value | R/W | Description |
|-----|----------|---------------|-----|--|
| 7 | SVA6 | 0 | R/W | Slave Address 6 to 0 |
| 6 | SVA5 | 0 | R/W | Set slave address. |
| 5 | SVA4 | 0 | R/W | |
| 4 | SVA3 | 0 | R/W | |
| 3 | SVA2 | 0 | R/W | |
| 2 | SVA1 | 0 | R/W | |
| 1 | SVA0 | 0 | R/W | |
| 0 | FS | 0 | R/W | Format Select In conjunction with the FSX bit in SARX, this bit selects the transfer format. See table 14.2. To identify the general call address, this bit should always be set to 0. |

14.3.3 Second Slave-Address Register (SARX)

SARX sets the transfer format and stores the second slave address. In slave mode of the I²C bus format, if the FS bit is set to 0 and the upper seven bits of SARX match the upper seven bits of the first frame received after a start condition, this module operates as the slave device specified by the master device. SARX can be accessed only when the ICE bit in ICCR is set to 0.

| Bit | Bit Name | Initial Value | R/W | Description |
|-----|----------|---------------|-----|---|
| 7 | SVAX6 | 0 | R/W | Second Slave Address 6 to 0 |
| 6 | SVAX5 | 0 | R/W | Set second slave address. |
| 5 | SVAX4 | 0 | R/W | |
| 4 | SVAX3 | 0 | R/W | |
| 3 | SVAX2 | 0 | R/W | |
| 2 | SVAX1 | 0 | R/W | |
| 1 | SVAX0 | 0 | R/W | |
| 0 | FSX | 1 | R/W | Format Select X In conjunction with the FS bit in SAR, this bit selects the transfer format. See table 14.2. |

Table 14.2 Transfer Format

| SAR | SARX | Operating Mode |
|-----|------|---|
| FS | FSX | |
| 0 | 0 | I ² C bus format <ul style="list-style-type: none"> • Enables the slave addresses in SAR and SARX • Enables the general call address |
| | 1 | I ² C bus format <ul style="list-style-type: none"> • Enables the slave address in SAR • Disables the slave address in SARX • Enables the general call address |
| 1 | 0 | I ² C bus format <ul style="list-style-type: none"> • Disables the slave address in SAR • Enables the slave address in SARX • Disables the general call address |
| | 1 | Synchronous serial format <ul style="list-style-type: none"> • Disables the slave addresses in SAR and SARX • Disables the general call address |

14. I²C Bus Interface (IIC) Option

- I²C bus format:
Addressing format with an acknowledge bit
- Synchronous serial format:
Non-addressing format without an acknowledge bit, and with master operation only

14.3.4 I²C Bus Mode Register (ICMR)

ICMR sets the transfer format and transfer rate. ICMR is only accessible when the ICE bit in ICCR is set to 1.

| Bit | Bit Name | Initial Value | R/W | Description |
|-----|----------|---------------|-----|---|
| 7 | MLS | 0 | R/W | MSB First/LSB First Select 0: MSB first 1: LSB first When this module is used in the I ² C bus format, this bit should be set to 0. |
| 6 | WAIT | 0 | R/W | Wait Insertion This bit is enabled only in master mode of the I ² C bus format. 0: A wait state is not inserted, and data and the acknowledge bit are transferred consecutively. 1: After the clock for the final bit of the data (8th cycle) become low, the IRIC flag in ICCR is set to 1, and a wait state is entered (with SCL at the low level). Clearing the IRIC flag in ICCR to 0 cancels the wait state. The acknowledge bit is then transferred. For details, refer to section 14.4.7, Timing for Setting IRIC and the Control of SCL. |
| 5 | CKS2 | 0 | R/W | Transfer Clock Select 2 to 0 |
| 4 | CKS1 | 0 | R/W | The CKS2 to CKS0 bits, together with the IICX0 bit in |
| 3 | CKS0 | 0 | R/W | SCRX, select the frequency of the transfer clock. This is used in the master mode. See table 14.3. |

| Bit | Bit Name | Initial Value | R/W | Description |
|-----|----------|---------------|-----|---|
| 2 | BC2 | 0 | R/W | Bit Counter |
| 1 | BC1 | 0 | R/W | These bits specify the number of bits to be transferred in the next transfer. Set the BC2 to BC0 bits in the intervals between the transfer of frames. Set the BC2 to BC0 bits to other than 000 when SCL is low. The bit counter is initialized to 000 on detection of the start condition. In addition, this counter returns to 000 on completion of the transfer of all data. |
| 0 | BC0 | 0 | R/W | |
| | | | | |
| | | | | I2C bus format Synchronous serial format |
| | | | | 000: 9 bits 000: 8 bits |
| | | | | 001: 2 bits 001: 1 bit |
| | | | | 010: 3 bits 010: 2 bits |
| | | | | 011: 4 bits 011: 3 bits |
| | | | | 100: 5 bits 100: 4 bits |
| | | | | 101: 6 bits 101: 5 bits |
| | | | | 110: 7 bits 110: 6 bits |
| | | | | 111: 8 bits 111: 7 bits |

Table 14.3 Setting of the Transfer Rate

| SCRX | | | | | Transfer Rate | | | | | | |
|------|------|------|------|---------------|---------------|------------|------------|------------|------------|------------|---------|
| Bit5 | Bit5 | Bit4 | Bit3 | | P ϕ = | P ϕ = | P ϕ = | P ϕ = | P ϕ = | P ϕ = | |
| IICX | CKS2 | CKS1 | CKS0 | Clock | 10MHz | 16MHz | 20MHz | 25MHz | 33MHz | 40MHz | |
| 0 | 0 | 0 | 0 | P ϕ /28 | 357kHz | 571kHz* | 714kHz* | 893kHz* | 1.18MHz* | 1.43MHz* | |
| | | | 1 | P ϕ /40 | 250kHz | 400kHz | 500kHz* | 625kHz* | 825kHz* | 1.00MHz* | |
| | | | 1 | 0 | P ϕ /48 | 208kHz | 333kHz | 417kHz* | 521kHz* | 688kHz* | 833kHz* |
| | | | 1 | P ϕ /64 | 156kHz | 250kHz | 313kHz | 391kHz | 516kHz* | 625kHz* | |
| | 1 | 0 | 0 | 0 | P ϕ /80 | 125kHz | 200kHz | 250kHz | 313kHz | 413kHz* | 500kHz* |
| | | | | 1 | P ϕ /100 | 100kHz | 160kHz | 200kHz | 250kHz | 330kHz | 400kHz |
| | | 1 | 0 | 0 | P ϕ /112 | 89.3kHz | 143kHz | 179kHz | 223kHz | 295kHz | 357kHz |
| | | | | 1 | P ϕ /128 | 78.1kHz | 125kHz | 156kHz | 195kHz | 258kHz | 313kHz |
| 1 | 0 | 0 | 0 | P ϕ /56 | 179kHz | 286kHz | 357kHz | 446kHz* | 589kHz* | 714kHz | |
| | | | 1 | P ϕ /80 | 125kHz | 200kHz | 250kHz | 313kHz | 413kHz* | 500kHz* | |
| | | | 1 | 0 | P ϕ /96 | 104kHz | 167kHz | 208kHz | 260kHz | 344kHz | 417kHz* |
| | | | 1 | P ϕ /128 | 78.1kHz | 125kHz | 156kHz | 195kHz | 258kHz | 313kHz | |
| | 1 | 0 | 0 | 0 | P ϕ /160 | 62.5kHz | 100kHz | 125kHz | 156kHz | 206kHz | 250kHz |
| | | | | 1 | P ϕ /200 | 50.0kHz | 80.0kHz | 100kHz | 125kHz | 165kHz | 200kHz |
| | | 1 | 0 | 0 | P ϕ /224 | 44.6kHz | 71.4kHz | 89.3kHz | 112kHz | 147kHz | 177kHz |
| | | | | 1 | P ϕ /256 | 39.1kHz | 62.5kHz | 78.1kHz | 97.7kHz | 129kHz | 156kHz |

Note: * Out of the I²C bus interface specification (Normal mode: maximum 100 kHz, High speed mode: maximum 400 kHz)

Due to factors such as load conditions, it may not be possible to obtain the designated transfer rate when the value of IICX is 0 and the peripheral clock ϕ frequency exceeds 16 MHz. Set IICX to 1 when P ϕ is greater than 16 MHz.

14.3.5 I²C Bus Control Register (ICCR)

ICCR controls I²C bus interface and confirms the state of interrupt flag.

| Bit | Bit Name | Initial Value | R/W | Description |
|-----|----------|---------------|-----|--|
| 7 | ICE | 0 | R/W | <p>I²C Bus Interface Enable</p> <p>0: This module is not operating. The internal state of the I²C module is cleared. Access to SAR and SARX is enabled.</p> <p>1: This module is in its transfer-enabled state</p> |
| 6 | IEIC | 0 | R/W | <p>I²C Bus Interface Interrupt Enable</p> <p>0: Disables the interrupt from the I²C bus interface to the CPU</p> <p>1: Enables the interrupt from the I²C bus interface to the CPU</p> |

| Bit | Bit Name | Initial Value | R/W | Description |
|-----|----------|---------------|-----|---|
| 5 | MST | 0 | R/W | Master/Slave Select |
| 4 | TRS | 0 | R/W | <p>Transmission/Reception Select</p> <p>00: Slave receive mode 01: Slave transmit mode 10: Master receive mode 11: Master transmit mode</p> <p>Both MST and TRS bits will be cleared by hardware when they lose in a bus contention in master mode of the I²C bus format. The mode changes to slave receive mode. When the I²C bus format is used in the slave-receive mode, transmission or reception is automatically selected by the hardware, according to the setting of the R/\bar{W} bit of the first frame after the start condition has been satisfied.</p> <p>Even if an attempt is made to change the TRS bit during the transfer of data, the change is suspended until transmission of data has been completed; the bit is then changed.</p> <p>[MST clearing conditions]</p> <ol style="list-style-type: none"> 1. Writing of 0 to this bit by software 2. Lose in a bus contention in master mode of the I²C bus format <p>[MST setting conditions]</p> <ol style="list-style-type: none"> 1. Writing of 1 to this bit by software (MST clearing condition 1) 2. Writing of 1 to this bit after reading MST = 0 (MST clearing condition 2) <p>[TRS clearing conditions]</p> <ol style="list-style-type: none"> 1. Writing of 0 to this bit by software (except TRS setting condition 3) 2. Writing of 0 to this bit after TRS = 1 is read (TRS setting condition 3) 3. Lose in a bus contention in master mode of the I²C bus format <p>[TRS setting conditions]</p> <ol style="list-style-type: none"> 1. Writing of 1 to this bit by software (except TRS clearing condition 3) 2. Writing of 1 to this bit after reading TRS = 0 (TRS clearing condition 3) 3. When 1 is received as the R/\bar{W} bit of the first frame address matched in the I²C bus format in slave mode. |

| Bit | Bit Name | Initial Value | R/W | Description |
|-----|----------|---------------|-----|--|
| 3 | ACKE | 0 | R/W | <p>Enables/Disables Acknowledge Bit</p> <p>0: The value of the acknowledge bit is ignored to allow the continuous transfer of data. The received value of the acknowledge bits that are received do not affect the ACKB bit; the value in the ACKB bit in ICSR remains at 0.</p> <p>1: When the value of the acknowledge bits received in the I²C bus format is 1, transmission is suspended.</p> <p>The acknowledge bit is used in two different ways, depending on the situation. One case is that the acknowledge bit is used as a kind of flag to indicate whether or not processing for the reception of data has been completed.</p> <p>The other case is that acknowledge bit is fixed to 1.</p> |
| 2 | BBSY | 0 | R/W | Bus Busy |
| 0 | SCP | 1 | W | <p>Start/Stop Condition Issuance Disable</p> <p>Master mode:</p> <ul style="list-style-type: none"> Write 0 to BBSY and SCP: Issuing stop condition Write 1 to BBSY and 0 to SCP: Issuing start condition and re-transmitting start condition <p>Slave mode:</p> <ul style="list-style-type: none"> Writing to the BBSY flag is disabled <p>[BBSY setting condition]</p> <ul style="list-style-type: none"> When SDA changes from high to low while SCL is high, the system regards the start condition as having been set. <p>[BBSY clearing condition]</p> <ul style="list-style-type: none"> When SDA changes from low to high while SDA is high, the system regards the stop condition as having been set. <p>The start and stop conditions are issued by using the MOV instruction.</p> <p>The I²C bus interface must be set to master transmit mode before the start condition is issued. Before writing 1 to BBSY and 0 to SCP, set MST and TRS to 1.</p> <p>The BBSY flag may be read to confirm whether or not the I²C bus (SCL, SDA) has been released.</p> <p>The SCP bit is always read as 1. Data is not stored even if 0 is written to the SCP bit.</p> |

| Bit | Bit Name | Initial Value | R/W | Description |
|-----|----------|---------------|--------|---|
| 1 | IRIC | 0 | R/(W)* | <p>I²C Bus Interface Interrupt Request Flag</p> <p>The IRIC flag indicates that the I²C bus interface has generated an interrupt request for the CPU.</p> <p>The timing with which the IRIC flag is set changes according to the combination of the values of the FS bit in SAR, the FSX bit in SARX and the WAIT bit in ICMR. Refer to section 14.4.7, Timing for Setting IRIC and the Control of SCL. In addition, the condition on which the IRIC flag is set changes according to the setting of the ACKE bit in ICCR.</p> <p>[Setting conditions]</p> <ul style="list-style-type: none"> I²C bus format in master mode <ul style="list-style-type: none"> When the start condition is detected from the bus line state after the start condition has been set. (i.e., when the ICDRE flag is set to 1 for transmission of the first frame). When WAIT = 1, a wait is inserted between the data bits and the acknowledge bit. (i.e., at the falling edge of the 8th transmit/receive clock) When the transfer of data has been completed. (i.e., at the rising edge of the 9th cycle of transmit/receive clock with no wait inserted) When a slave address is received after bus conflict is lost. (i.e., first frame following start condition) When the ACKE bit is 1, and 1 is received as an acknowledge bit. (i.e., when the ACKB bit is set to 1). When the AL flag is set to 1 because of a bus conflict. |

| Bit | Bit Name | Initial Value | R/W | Description |
|-----|----------|---------------|--------|---|
| 1 | IRIC | 0 | R/(W)* | <ul style="list-style-type: none"> I²C bus format in the slave mode <p>When a slave address (SVA or SVAX) matches (i.e., when the AAS or AASX flag is set to 1), and at the end of data transfer up to the subsequent retransmission start condition or stop condition detection (i.e., at the rising edge of the 9th cycle of transmission or receive clock)</p> <p>When the general call address has been detected (i.e., when 0 is received for R/W and the ADZ flag is set to 1) and at the end of data reception up to the subsequent retransmission start condition or stop condition detection (i.e., at the rising edge of the 9th cycle of receive clock)</p> <p>When the ACKE bit is 1, and 1 is received as an acknowledge bit (i.e., when the ACKB bit is set to 1)</p> <p>When the stop condition is detected while the STOPIM bit is 0 (i.e., when the STOP or the ESTP flag is set to 1)</p> Synchronous serial format <p>When the transfer of data has been completed (i.e., at the rising edge of the 8th transmit/receive clock)</p> <p>When a start condition is detected with serial format</p> When a condition occurs in which the ICDRE or ICDRF flag is set to 1 in any operating mode. <p>When a start condition is detected in transmit mode (i.e., when a start condition is detected and the ICDRE flag is set to 1 in transmit mode)</p> <p>When transmitting the data in the ICDR register buffer (i.e., when data is transferred from ICDRT to ICDDRS in transmit mode and the ICDRE flag is set to 1, or data is transferred from ICDRS to ICDDRR in receive mode and the ICDRF flag is set to 1.)</p> <p>[Clearing conditions]</p> <ul style="list-style-type: none"> When 0 is written in IRIC after reading IRIC = 1 When ICDR is read or written to by DTC <p>(This may not be a clearing condition. For details, see the following operation description on DTC.)</p> |

Note: * Only 0 can be written to clear the flag.

When the DTC is used, the IRIC flag is cleared automatically and transfer can be performed continuously without CPU intervention. When the interface is in the I²C bus format and an interrupt is generated so that IRIC becomes 1, other flags must be checked to locate the cause of the IRIC bit becoming 1. Each possible cause has a corresponding flag. Precautions must be taken when the data transfer has been completed.

When the ICDRE or ICDRF flag is set, the IRTR flag may be set, but in some cases it will not be. In the I²C bus format in the slave mode, the IRTR flag, which is the DTC-activation request flag, is not set during the period between the completion of data transfer after a slave-address (SVA) match or a general call address match and the detection of the stop condition or transmission of the next start condition. Even when the IRIC or IRTR flag has been set, the ICDRE or ICDRF flag may not be set in some cases. When a continuous transfer is performed using the DTC, the IRIC or IRTR flag is not cleared when the specified number of transfers is completed. On the other hand, since the specified number of read/write operations has been completed, the ICDRE or the ICDRF flag will already have been cleared.

The relationship between the flags and the various states of transfer is shown in table 14.4 and table 14.5.

Table 14.4 The Relationship between Flags and Transfer States (Master Mode)

| MST | TRS | BBSY | ESTP | STOP | IRTR | AASX | AL | AAS | ADZ | ACKB | ICDRF | ICDRE | State |
|-----|-----|------|------|------|------|------|----|-----|-----|------|-------|-------|---|
| 1 | 1 | 0 | 0 | 0 | 0 | 0↓ | 0 | 0↓ | 0↓ | 0 | — | 0 | Idle state (flag clearing required) |
| 1 | 1 | 1↑ | 0 | 0 | 1↑ | 0 | 0 | 0 | 0 | 0 | — | 1↑ | Start condition detected |
| 1 | — | 1 | 0 | 0 | — | 0 | 0 | 0 | 0 | — | — | — | Wait state |
| 1 | 1 | 1 | 0 | 0 | — | 0 | 0 | 0 | 0 | 1↑ | — | — | Transmission end (ACKE = 1 and ACKB = 1) |
| 1 | 1 | 1 | 0 | 0 | 1↑ | 0 | 0 | 0 | 0 | 0 | — | 1↑ | Transmission end with ICDRE = 0 |
| 1 | 1 | 1 | 0 | 0 | — | 0 | 0 | 0 | 0 | 0 | — | 0↓ | ICDR write with the above state |
| 1 | 1 | 1 | 0 | 0 | — | 0 | 0 | 0 | 0 | 0 | — | 1 | Transmission end with ICDRE = 1 |
| 1 | 1 | 1 | 0 | 0 | — | 0 | 0 | 0 | 0 | 0 | — | 0↓ | ICDR write with the above state or after start condition detected |
| 1 | 1 | 1 | 0 | 0 | 1↑ | 0 | 0 | 0 | 0 | 0 | — | 1↑ | Automatic data transfer from ICDRT to ICDRS with the above state |
| 1 | 0 | 1 | 0 | 0 | 1↑ | 0 | 0 | 0 | 0 | — | 1↑ | — | Reception end with ICDRF = 0 |
| 1 | 0 | 1 | 0 | 0 | — | 0 | 0 | 0 | 0 | — | 0↓ | — | ICDR read with the above state |
| 1 | 0 | 1 | 0 | 0 | — | 0 | 0 | 0 | 0 | — | 1 | — | Reception end with ICDRF = 1 |
| 1 | 0 | 1 | 0 | 0 | — | 0 | 0 | 0 | 0 | — | 0↓ | — | ICDR read with the above state |
| 1 | 0 | 1 | 0 | 0 | 1↑ | 0 | 0 | 0 | 0 | — | 1↑ | — | Automatic data transfer from ICDRS to ICDRR with the above state |
| 0↓ | 0↓ | 1 | 0 | 0 | — | 0 | 1↑ | 0 | 0 | — | — | — | Arbitration lost |
| 1 | — | 0↓ | 0 | 0 | — | 0 | 0 | 0 | 0 | — | — | 0↓ | Stop condition detected |

[Legend]

0: 0-state retained

1: 1-state retained

—: Previous state retained

0↓: Cleared to 0

1↑: Set to 1

Table 14.5 The Relationship between Flags and Transfer States (Slave Mode)

| MST | TRS | BBSY | ESTP | STOP | IRTR | AASX | AL | AAS | ADZ | ACKB | ICDRF | ICDRE | State |
|-----|--------------|------|--------------|--------------|--------------|------|----|-----|-----|------|-------|-------|--|
| 0 | 0 | 0 | 0 | 0 | 0 | 0 | 0 | 0 | 0 | 0 | — | 0 | Idle state (flag clearing required) |
| 0 | 0 | 1↑ | 0 | 0 | 0 | 0↓ | 0 | 0 | 0 | 0 | — | 1↑ | Start condition detected |
| 0 | 1↑/0 (*1) | 1 | 0 | 0 | 0 | 0 | — | 1↑ | 0 | 0 | 1↑ | 1 | SAR match in the first frame (SARX ≠ SAR) |
| 0 | 0 | 1 | 0 | 0 | 0 | 0 | — | 1↑ | 1↑ | 0 | 1↑ | 1 | General call address match in the first frame (SARX ≠ H'00) |
| 0 | 1↑/0 (*1) | 1 | 0 | 0 | 1↑ | 1↑ | — | 0 | 0 | 0 | 1↑ | 1 | SARX match in the first frame (SAR ≠ SARX) |
| 0 | 1 | 1 | 0 | 0 | — | — | — | — | 0 | 1↑ | — | — | Transmission end (ACKE = 1 and ACKB = 1) |
| 0 | 1 | 1 | 0 | 0 | 1↑/0 (*2) | — | — | — | 0 | 0 | — | 1↑ | Transmission end with ICDRE = 0 |
| 0 | 1 | 1 | 0 | 0 | — | — | 0↓ | 0↓ | 0 | 0 | — | 0↓ | ICDR write with the above state |
| 0 | 1 | 1 | 0 | 0 | — | — | — | — | 0 | 0 | — | 1 | Transmission end with ICDRE = 1 |
| 0 | 1 | 1 | 0 | 0 | — | — | 0↓ | 0↓ | 0 | 0 | — | 0↓ | ICDR write with the above state |
| 0 | 1 | 1 | 0 | 0 | 1↑/0 (*2) | — | 0 | 0 | 0 | 0 | — | 1↑ | Automatic data transfer from ICDR to ICDRS in the above state |
| 0 | 0 | 1 | 0 | 0 | 1↑/0 (*2) | — | — | — | — | — | 1↑ | — | Reception end with ICDRF = 0 |
| 0 | 0 | 1 | 0 | 0 | — | — | 0↓ | 0↓ | 0↓ | — | 0↓ | — | ICDR read with the above state |
| 0 | 0 | 1 | 0 | 0 | — | — | — | — | — | — | 1 | — | Reception end with ICDRF = 1 |
| 0 | 0 | 1 | 0 | 0 | — | — | 0↓ | 0↓ | 0↓ | — | 0↓ | — | ICDR read with the above state |
| 0 | 0 | 1 | 0 | 0 | 1↑/0 (*2) | — | 0 | 0 | 0 | — | 1↑ | — | Automatic data transfer from ICDRS to ICDRR with the above state |
| 0 | — | 0↓ | 1↑/0 (*3) | 0/1↑ (*3) | — | — | — | — | — | — | — | 0↓ | Stop condition detected |

[Legend]

0: 0-state retained

1: 1-state retained

—: Previous state retained

0: Cleared to 0

1: Set to 1

Notes: 1. Set to 1 when 1 is received as a R/ \overline{W} bit following an address.

2. Set to 1 when the AASX bit is set to 1.

3. STOP is 0 when ESTP = 1, or ESTP is 0 when STOP = 1.

14.3.6 I²C Bus Status Register (ICSR)

ICSR includes flags that indicate bus states. See also table 14.4 and table 14.5.

| Bit | Bit Name | Initial Value | R/W | Description |
|-----|----------|---------------|--------|--|
| 7 | ESTP | 0 | R/(W)* | <p>Erroneous Stop Condition Detection Flag</p> <p>This bit is enabled in the I²C bus format in the slave mode.</p> <p>[Setting condition]</p> <ul style="list-style-type: none"> Detection of the stop condition during the transfer of one frame <p>[Clearing conditions]</p> <ul style="list-style-type: none"> Writing of 0 to this bit after reading ESTP = 1 Clearing of the IRIC flag to 0 |
| 6 | STOP | 0 | R/(W)* | <p>Normal Stop Condition Detection Flag</p> <p>This bit is enabled in the I²C bus format in the slave mode.</p> <p>[Setting condition]</p> <ul style="list-style-type: none"> Detection of the stop condition after the transfer of one frame <p>[Clearing conditions]</p> <ul style="list-style-type: none"> Writing of 0 to this bit after reading STOP = 1 Clearing of the IRIC flag to 0 |
| 5 | IRTR | 0 | R/(W)* | <p>I²C Bus Interface Continuous Transfer Interrupt Request Flag</p> <p>The IRTR flag indicates that the I²C bus interface has generated an interrupt for the CPU at the end of transmission and reception one frame of data. The IRIC flag is set to 1 at the same time as the IRTR flag is set to 1.</p> <p>[Setting conditions]</p> <ul style="list-style-type: none"> Setting of the ICDRE or ICDRF flag to 1 while AASX is 1 in the I²C bus interface in the slave mode. Setting of the ICDRE or ICDRF flag to 1, when in master mode in I2C bus interface or synchronous serial format <p>[Clearing conditions]</p> <ul style="list-style-type: none"> Writing of 0 to this bit after reading IRTR = 1 Clearing of the IRIC flag to 0 with ICE = 0 |

| Bit | Bit Name | Initial Value | R/W | Description |
|-----|----------|---------------|--------|---|
| 4 | AASX | 0 | R/(W)* | <p>Second Slave Address Detection Flag</p> <p>In the I²C bus format in the slave mode, this bit indicates that the first frame after the start condition matches bits SVAX6 to SVAX0 in SARX.</p> <p>[Setting condition]</p> <ul style="list-style-type: none"> Detection of the second slave address in the slave receive mode while FSX = 0. <p>[Clearing conditions]</p> <ul style="list-style-type: none"> Writing of 0 to this bit after reading AASX = 1 Detection of the start condition. Entering master mode |
| 3 | AL | 0 | R/(W)* | <p>Arbitration Lost Flag</p> <p>The AL flag indicates that the device, in master mode, has failed to acquire bus-master status.</p> <p>[Setting conditions]</p> <ul style="list-style-type: none"> When the interface is in master transmit mode, the SDA value it is generating internally and the value on the SDA pin do not match on the rising edge of SCL. When the start condition instruction has been executed in master transmit mode, then the SDA is driven to low by another device before drives the pin to low. <p>[Clearing conditions]</p> <ul style="list-style-type: none"> Writing of data to ICDR (during transmission) or reading of data from ICDR (during reception). Writing a 0 to this bit after reading it as 1 |

| Bit | Bit Name | Initial Value | R/W | Description |
|-----|----------|---------------|--------|--|
| 2 | AAS | 0 | R/(W)* | <p>Slave Address Detection Flag</p> <p>When the first frame after the start condition matches the SVA6 to SVA0 bits of SAR or when the general-call address (H'00) is detected in the I²C bus format in the slave receive mode.</p> <p>[Setting condition]</p> <ul style="list-style-type: none"> Detection of the slave address or general call address (one frame, including the R\overline{W} bit, is H'00) while in the slave-receive mode and FS = 0. <p>[Clearing conditions]</p> <ul style="list-style-type: none"> Writing of data to ICDR (during transmission) or reading of data from ICDR (during reception) Writing of 0 to this bit after reading it as 1 Entering the master mode |
| 1 | ADZ | 0 | R/(W)* | <p>General Call Address Detection Flag</p> <p>In the I²C bus format in the slave-reception mode, the general-call address (H'00) is detected in the first frame after the start condition.</p> <p>[Setting condition]</p> <ul style="list-style-type: none"> Detection of the general call address (one frame, including R\overline{W} bit, is H'00) in the slave-receive mode (FSX = 0 or FS = 0). <p>[Clearing conditions]</p> <ul style="list-style-type: none"> Writing of data to ICDR (during transmission) or reading of data from ICDR (during reception). Writing 0 to this bit after reading it as 1 Entering the master mode <p>When the general call address is detected while FS = 1 and FSX = 0, the ADZ flag is set to 1 but the general call address is not identified (the AAS flag is not set to 1).</p> |

| Bit | Bit Name | Initial Value | R/W | Description |
|-----|----------|---------------|-----|---|
| 0 | ACKB | 0 | R/W | <p>Acknowledge</p> <p>This bit stores the acknowledgements.</p> <p>Transmit mode:</p> <p>[Setting condition]</p> <ul style="list-style-type: none"> Reception of 1 as an acknowledge bit when ACKE is 1 in transmit mode. <p>[Clearing conditions]</p> <ul style="list-style-type: none"> Reception of 0 as an acknowledge bit when ACKE is 1 in transmit mode. Writing 0 to the ACKE bit <p>Receive mode:</p> <p>0: After reception of data, 0 is output as acknowledge data</p> <p>1: After reception of data, 1 is output as acknowledge data</p> <p>When this bit is read, the value that was loaded here (the value returned from the receiving device) is read during transmission (TRS = 1). During receive operations (TRS = 0), the value that was set is read.</p> <p>When this bit is written, acknowledge data that is returned after receiving is rewritten regardless of the TRS value. If the ICSR register flag is written using bit-manipulation instructions, the acknowledge data should be set again since the acknowledge data setting is rewritten by the reading value of ACKB bit.</p> <p>Write the ACKE bit to 0 to clear the ACKB flag to 0, before transmission is ended and a stop condition is issued in master mode, or before transmission is ended and SDA is released to issue a stop condition by a master device.</p> |

Note: * Only 0 can be written to clear the flag.

14.3.7 Serial Control Register X (SCRX)

SCRX enables or disables I²C bus interface interrupts and confirms the state of reception and transmission.

| Bit | Bit Name | Initial Value | R/W | Description |
|------|----------|---------------|-----|---|
| 7, 6 | — | All 0 | R | Reserved These bits are always read as 0. The write value should always be 0. |
| 5 | IICX | 0 | R/W | I ² C Transfer Rate Select Along with bits CKS2 to CKS0 in the I ² C bus mode register (ICMR), this bit selects the transfer rate in the master mode. For details on setting the transfer rate, see table 14.3. |
| 4 | IICE | 0 | R/W | I ² C master Enable This bit controls access by the CPU to the I ² C bus interface registers (ICCR, ICSR, ICDR/SARX, and ICMR/SAR) of the I ² C bus interface. 0: Disables CPU access to the registers of the I ² C bus interface. 1: Enables CPU access to the registers of the I ² C bus interface. |
| 3 | HNDS | 0 | R/W | Hand-Shake Receive Select This bit enables/disables continuous reception in receive mode. When the HNDS bit is cleared to 0, receive operation is performed continuously after data has been received successfully while ICDRF flag is 0. When the HNDS bit is set to 1, SCL is fixed to the low level thus disabling the next data to be transferred. The bus line is released and next frame receive operation is enabled by reading the receive data in ICDR. |
| 2 | — | 0 | R | Reserved This bit is always read as 0. The write value should always be 0. |

| Bit | Bit Name | Initial Value | R/W | Description |
|-----|----------|---------------|-----|---|
| 1 | ICDRF0 | 0 | R | <p>Receive Data Read Request Flag</p> <p>Indicates the ICDR (ICDRR) state in receive mode.</p> <p>0: Indicates that the data has already been read from ICDR (ICDRR) or ICDR is initialized.</p> <p>1: Indicates that data has been received successfully and transferred from ICDRS to ICDRR, and the data is not read yet.</p> <p>[Setting condition]</p> <ul style="list-style-type: none"> • When data is received successfully and transferred from ICDRS to ICDRR. <ul style="list-style-type: none"> A. When data is received successfully while ICDRF = 0 (at the rising edge of the 9th cycle of the clock). B. When ICDR is read in receive mode after data was received while ICDRF = 1. <p>[Clearing conditions]</p> <ul style="list-style-type: none"> • When ICDR (ICDRR) is read. • When 0 is written to the ICE bit. <p>Due to the condition B above, ICDRF is temporarily cleared to 0 when ICDR (ICDRR) is read; however, since data is transferred from ICDRS to ICDRR immediately, ICDRF is set to 1 again.</p> <p>Note that ICDR cannot be read successfully in transmit mode (TRS = 1) because data is not transferred from ICDRS to ICDRR. Read data from ICDR in receive mode (TRS = 0) to read data in ICDR.</p> |
| 0 | STOPIM | 0 | R/W | <p>Stop Condition Detected Interrupt Mask</p> <p>This bit enables/disables the issuing of stop-condition-detected interrupt requests in the I²C bus format in the slave mode.</p> <p>0: This setting enables the IRIC flag setting and the stop-condition-detected interrupt requests (STOP = 1 or ESTP = 1) in the I²C bus format in slave mode.</p> <p>1: This setting disables the IRIC flag setting or the stop-condition-detected interrupt requests in the I²C bus format in slave mode.</p> |

14.3.8 ICDRE Flag (Internal Flag)

The ICDRE flag is set and cleared under the conditions as shown below. Since the ICDRE flag is an internal flag, it cannot be accessed.

| Bit Name | Initial Value | Description |
|----------|---------------|---|
| ICDRE | 0 | <p>Transmit Data Write Request Flag</p> <p>This flag is an internal flag that indicates the ICDR (ICDRT) state in transmission mode.</p> <p>0: Indicates that the data to be transmitted has been already written to ICDR (ICDRT) or ICDR is initialized.</p> <p>1: Indicates that data has been transferred from ICDRT to ICDRS and is being transmitted, or the start condition has been detected or transmission has been completed, thus allowing the next data to be written to.</p> <p>[Setting conditions]</p> <ul style="list-style-type: none"> • When the start condition is detected from the bus line state in I²C bus format or serial format. • When data is transferred from ICDRT to ICDRS. <ul style="list-style-type: none"> A. When data transmission is completed while ICDRE = 0 (at the rising edge of the 9th cycle of the clock). B. When ICDR is written to in transmit mode after data transmission is completed while ICDRE = 1. <p>[Clearing conditions]</p> <ul style="list-style-type: none"> • When transmit data is written to ICDR (ICDRT). • When the stop condition is detected in I²C bus format or serial format. • When 0 is written to the ICE bit. <p>Note that if the ACKE bit is set to 1 in I²C bus format thus enabling acknowledge bit decision, ICDRE is not set when data transmission is completed while the acknowledge bit is 1.</p> <p>Due to the set condition B above, ICDRE is temporarily cleared to 0 when data is written to ICDR (ICDRT); however, since data is transferred from ICDRT to ICDRS immediately, ICDRE is set to 1 again. Do not write data to ICDR when TRS = 0 because the ICDRE flag value is invalid during the time.</p> |

14.4 Operation

The I²C bus interface is capable of transferring data in either the serial format or the I²C bus format.

14.4.1 I²C Bus Data Formats

The I²C bus format is referred to as an addressing format. The transfer of data in this addressing format includes the transfer of acknowledge bits. This is shown in figure 14.3. The first frame after the start condition always consists of nine bits.

The serial format is referred to as a 'non-addressing format'. The transfer of data in this non-addressing format does not include the transfer of an acknowledge bit. This is shown in figure 14.4. The I²C bus timing is shown in figure 14.5.

The symbols used in figures 14.3 to 14.5 are described in table 14.6.

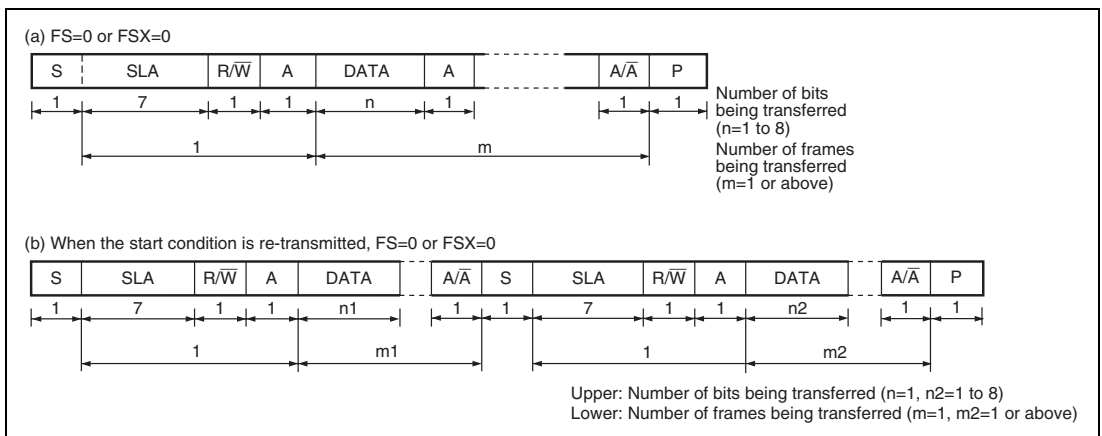

Figure 14.3 I²C Bus Data Format (I²C Bus Format)

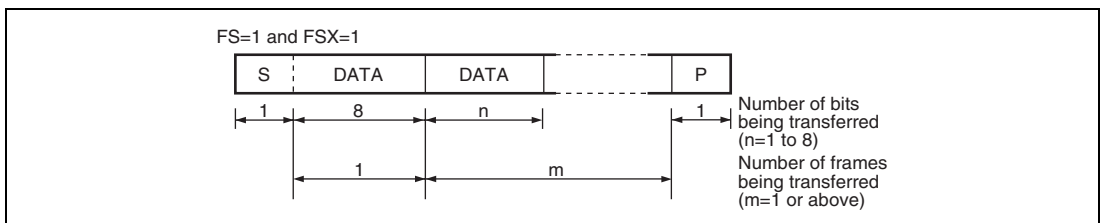

Figure 14.4 I²C Bus Data Format (Serial Format)

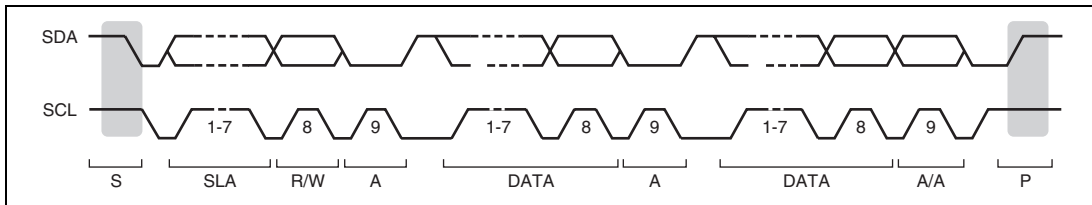

Figure 14.5 I²C Bus Timing

Table 14.6 I²C Bus Data Format: Description of Symbols

| | |
|------|--|
| S | This represents the start condition. The master device changes the level on SDA from high to low while SCL is high. |
| SLA | This represents the slave address. The master device sends this to select the slave device. |
| R/W | This represents the direction of transmission/reception. When the R/W bit is 1, data is transferred from the slave to the master device. When the R/W bit is 0, data is transferred from the master to the slave device. |
| A | This represents an acknowledgement. The receiving device sends this acknowledge bit by setting the level on SDA to low (during master transmission, the slave returns the acknowledge bits; during master reception, the master returns the acknowledge bits). |
| DATA | This represents the transfer of data. The amount of bits to be transferred in each such operation is set by the BC2 to BC0 bits of ICMR. The MLS bit in ICMR determines whether the data is transferred MSB first or LSB first. |
| P | This represents the stop condition. The master device changes the level on SDA from low to high while SCL is high. |

14.4.2 Initialization

Initialize the IIC following the procedure shown below before starting the data transmission or reception.

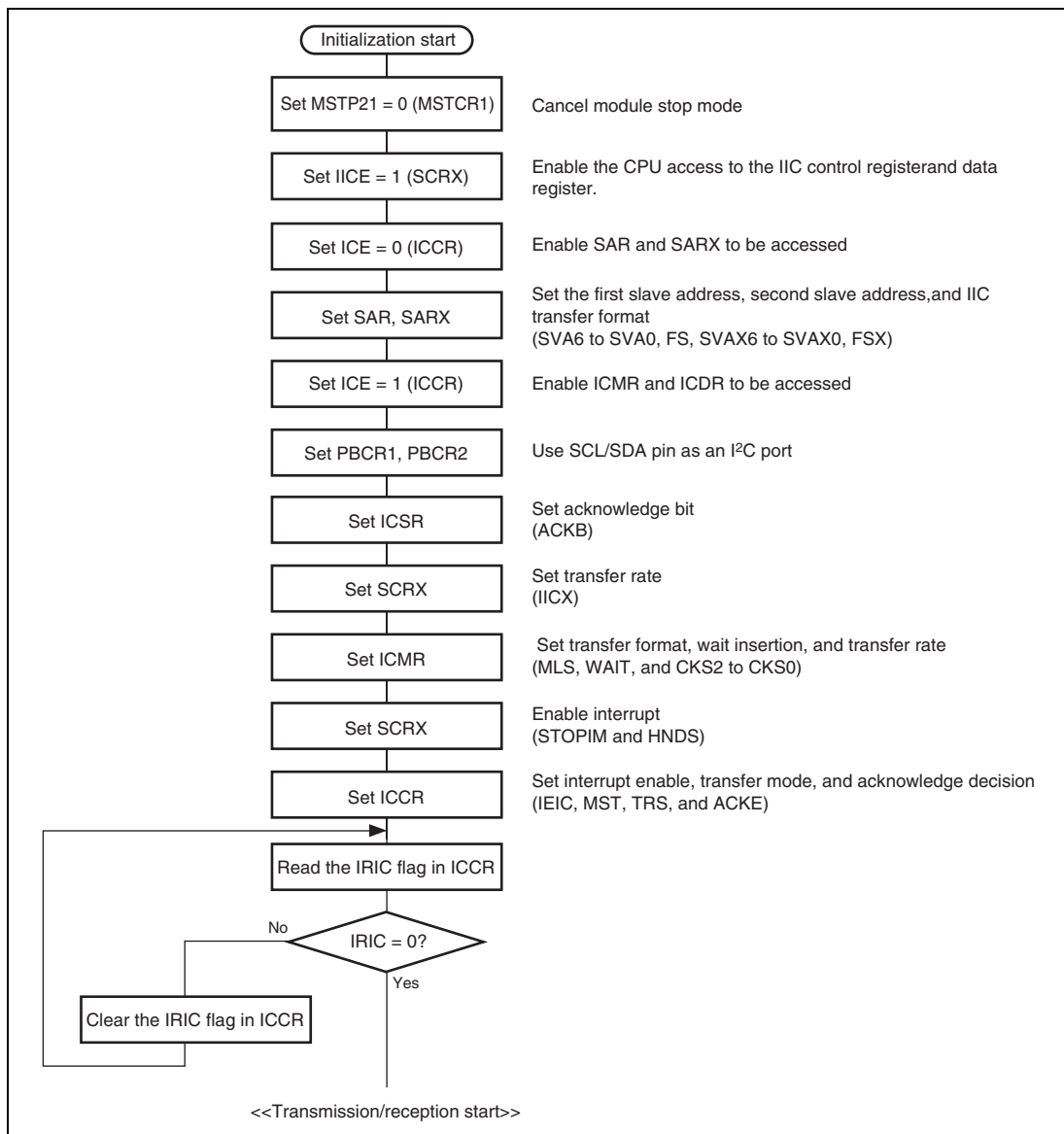

Figure 14.6 An Example of IIC Initialization Flowchart

Note: The ICMR register should be modified after transmit/receive operation has been completed. If the ICMR register is modified during transmit/receive operation, bit counter BC2 to BC0 will be modified illegally, thus causing malfunction.

14.4.3 Operations in Master Transmission

In I²C bus format in the master transmit mode, the master device outputs the transmit clock and data for transmission, and the slave device acknowledges its reception of data.

Figure 14.7 is a flowchart that gives an example of operations in master transmit mode.

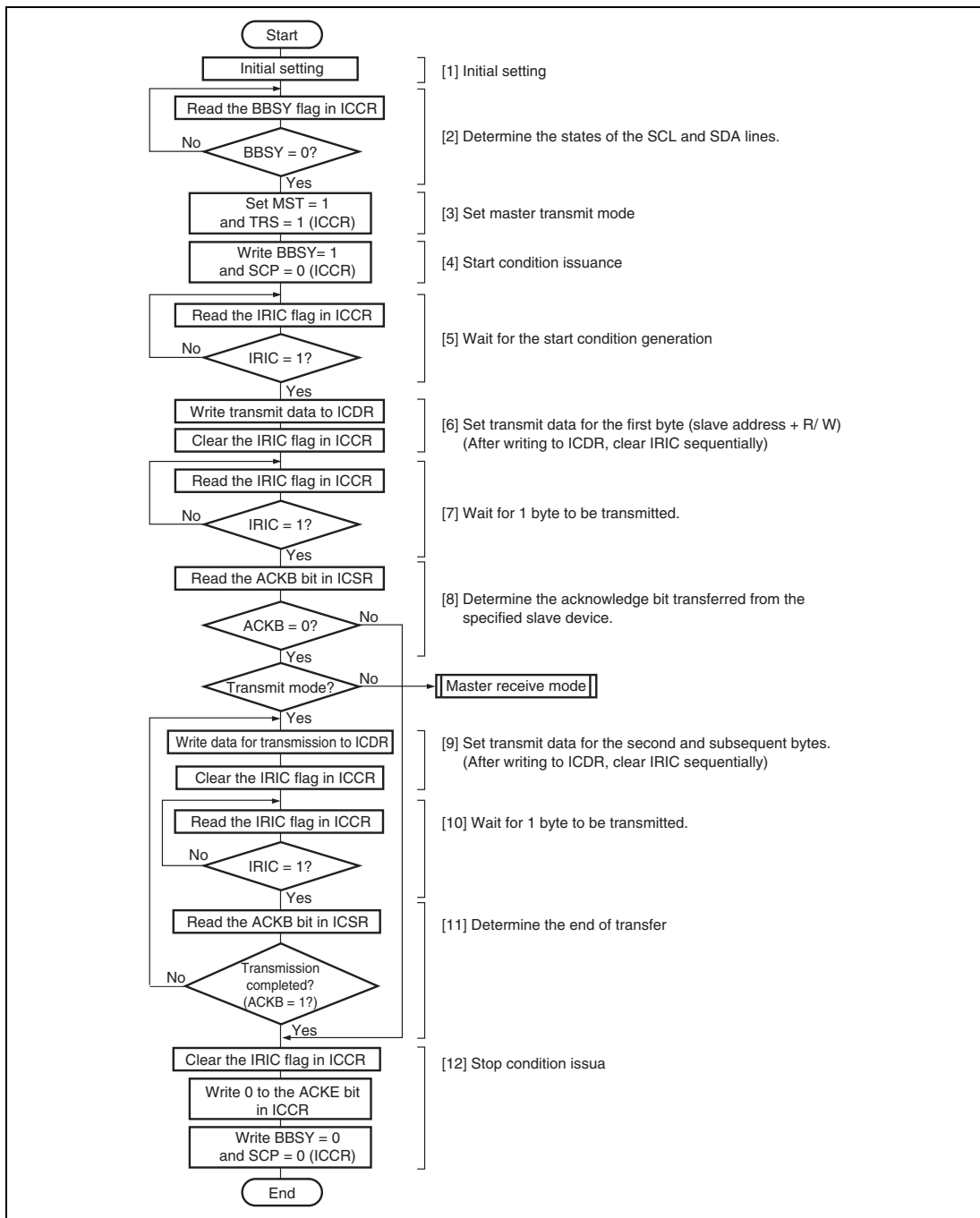

Figure 14.7 Example: Flowchart of Operations in the Master Transmit Mode

The following description gives the procedures to transmit data serially in synchronization with ICDR (ICDRT) writing operation.

1. Perform initialization according to the procedure described in section 14.4.2, Initialization.
2. Confirm that the bus is free by reading the BBSY flag in ICCR.
3. Set the MST and TRS bits in ICCR to 1 to select the master transmit mode.
4. Then write 1 to BBSY and 0 to SCP. This changes the level on SDA from high to low while SCL is high, and is thus the generation of the start condition.
5. With the generation of the start condition, the IRIC and IRTR flags are set to 1. When the IEIC bit in ICCR has been set to 1, an interrupt request is generated for the CPU.
6. Write the data (slave address + R/\overline{W}) to ICDR after the start condition is detected.
In the I²C bus format (when the FS bit in SAR or the FSX bit in SARX is 0), the first frame data following the start condition indicates the 7-bit slave address and transmit/receive direction (R/\overline{W}).
To determine the end of the transfer, the IRIC flag is cleared to 0.
After writing to ICDR, clear IRIC continuously in order that no other interrupt processing is executed. If the time for transmission of one frame of data has passed before the IRIC flag clearing, the end of transmission cannot be determined.
The master device transmits the transmit clock signal and the data written in the ICDR. To acknowledge its selection, the slave device that has been selected (that matches the slave address) sets the level on SDA low in the 9th cycle of the transmit clock.
7. When the transmission of one frame has been completed, the IRIC flag is set to 1 on the rising edge of the 9th cycle of the transmit clock. The level on SCL is automatically fixed low in synchronization with the internal clock until the next data for transmission has been written to ICDR.
8. Read the ACKB bit in ICSR to confirm $ACKB = 0$.
When the slave device does not return acknowledgement and $ACKB = 1$, execute transmit end processing in step 12 and carry out transmission again.
9. Write the transmit data to ICDR.
The IRIC flag is cleared to 0 to determine the end of the transfer.
Perform the ICDR writing and the IRIC flag clearing sequentially as in step 6.
Transmission of the next frame is performed in synchronization with the internal clock.
10. When the transmission of one frame has been completed, the IRIC flag is set to 1 on the rising edge of the 9th cycle of the transmit clock. The level on SCL is automatically fixed low in synchronization with the internal clock until the next data for transmission has been written to ICDR.

11. Read the ACKB bit in ICSR.

Confirm that the slave device returns acknowledgement (ACKB bit is 0). When there is still data to be transmitted, go to step 9 to continue the next transmission. When the slave device does not return acknowledgement (ACKB bit is set to 1), follow step 12 to end transmission.

12. Clear the IRIC flag to 0.

Write 0 to the ACKE bit in ICCR, to clear the received ACKB bit to 0.

Write 0 to BBSY and SCP in ICCR. This changes SDA from low to high when SCL is high, and generates the stop condition.

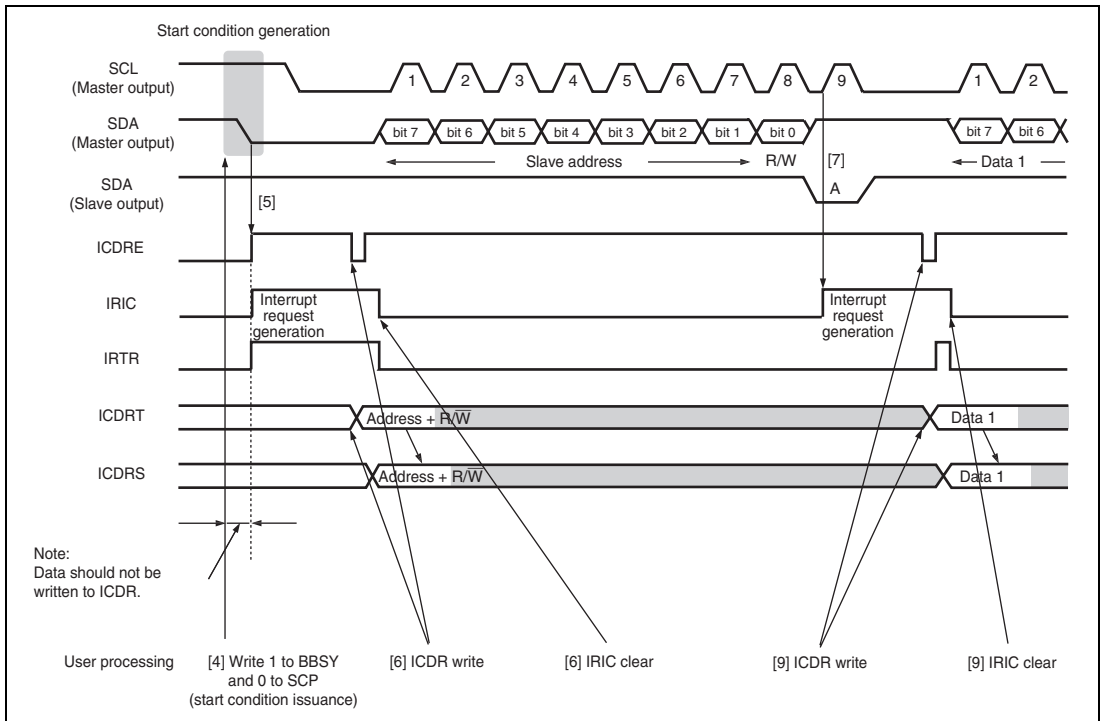

Figure 14.8 An Example of the Timing of Operations in Master Transmit Mode (MLS = WAIT = 0)

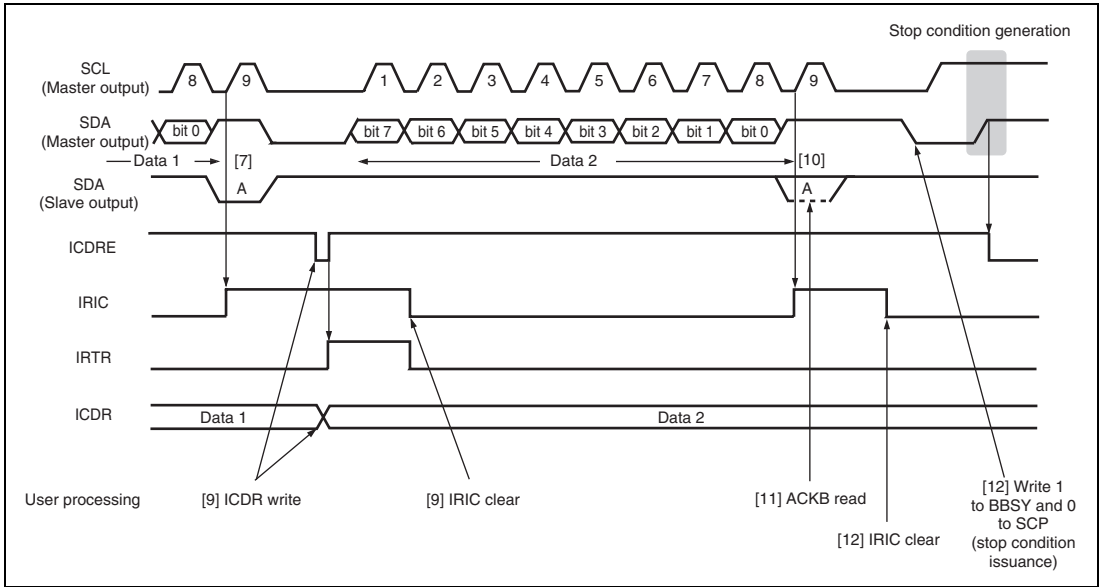

Figure 14.9 An Example of the Stop Condition Issuance Timing in Master Transmit Mode (MLS = WAIT = 0)

14.4.4 Operations in Master Reception

In master receive mode, the master device outputs the receive clock, receives data, and returns acknowledgements of reception. The slave device transmits the data.

The master device transmits data of the slave address + R/\overline{W} (1: Read) in the first frame after start condition issuance in master transmit mode. After the slave device is selected, operation is changed to reception.

Reception with HNDS Function (HNDS = 1):

Figure 14.10 is a flowchart that gives an example of operations in master receive mode (HNDS = 1).

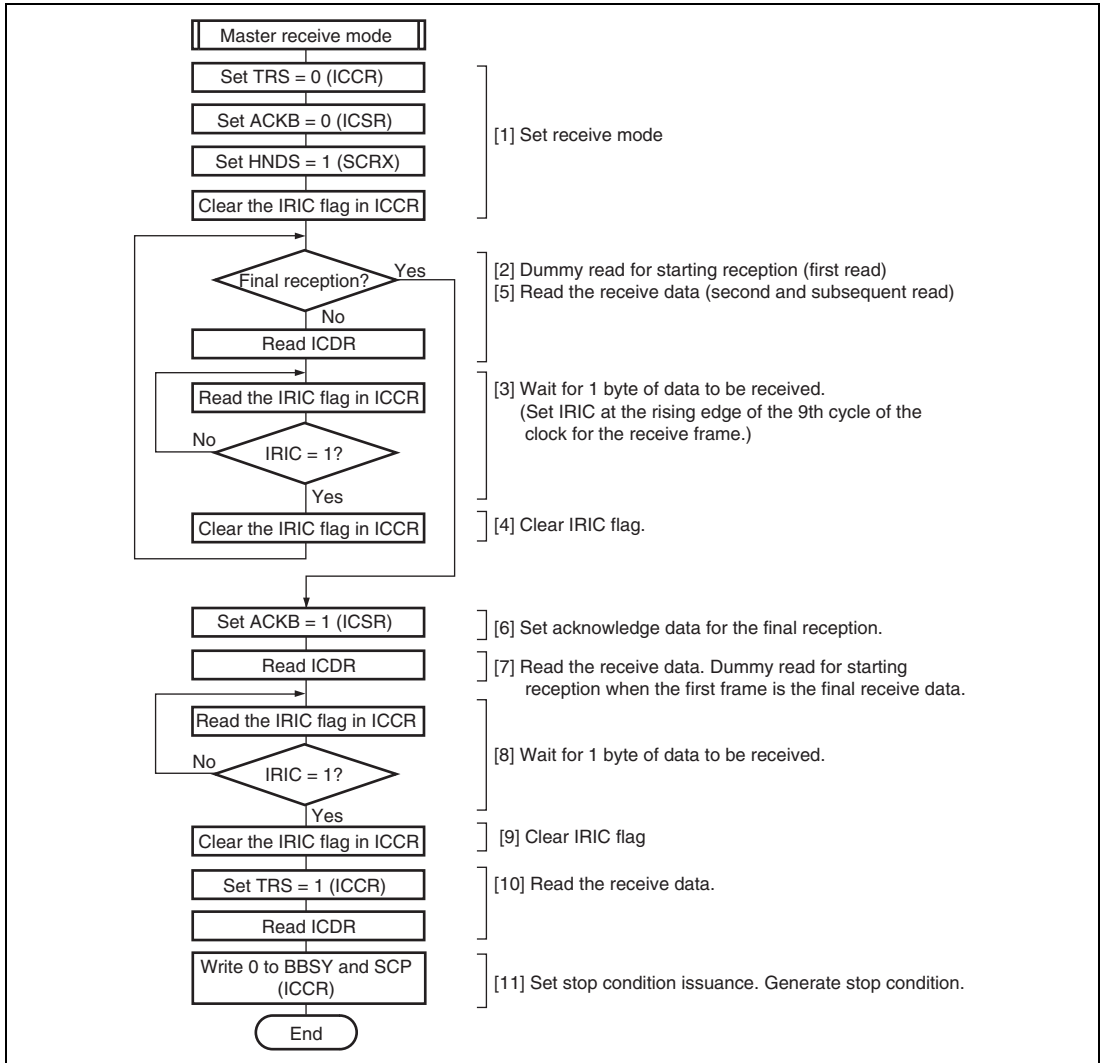

Figure 14.10 Example: Flowchart of Operations in the Master Receive Mode (HNDS = 1)

The following description gives the procedures for and operations of receiving data in one byte units by fixing SCL low for every data reception using the HNDS bit function.

1. Clear the TRS bit in ICCR to 0 to change from the transmit mode to the receive mode.
Clear the ACKB bit in ICSR to 0 (setting of the acknowledge data).
Set the HNDS bit in SCRX to 1.
Clear the IRIC flag to 0 to confirm that reception has been completed.
When the first frame is the final receive data, perform end processing in step 6 and subsequent steps.
2. When ICDR is read (a dummy read operation), the receiving of data starts; the receive clock is output in synchronization with the internal clock, and the first datum is then received. (Data of the SDA pin is stored in ICDRS in synchronization with the rising edge of receive clock.)
3. The master device sets SDA to low on the 9th cycle of the receive clock and returns the acknowledge bit. The receive data is transferred from ICDRS to ICDRR at the rising edge of the 9th cycle of the receive clock, and the ICDRF, IRIC, and IRTR flags are set to 1. When the IEIC bit in ICCR has been set to 1, an interrupt request is generated for the CPU. The master device fixes SCL low between at the falling edge of 9th cycle of the receive clock and read of ICDR data.
4. To identify the next interrupt, the IRIC flag is cleared to 0.
When the next frame is the final receive data, perform end processing in step 6 and subsequent steps.
5. Read the receive data of ICDR. This clears the ICDRF flag to 0, and the master device outputs the receive clock continuously for the reception of the next data.

Data can be received by repeating the steps 3 to 5.

6. Set the ACKB bit to 1 (setting of acknowledge data for the final reception).
7. Read ICDR receive data. This clears the ICDRF flag to 0. The master device outputs the receive clock to receive data.
8. When one frame of data has been received, the ICDRF, IRIC, and IRTR flags are set to 1 at the rising edge of the 9th cycle of receive clock.
9. Clear the IRIC flag to 0.
10. Read ICDR receives data after setting the TRS bit to 1. This clears the ICDRF flag to 0.
11. Write 0 to BBSY and SCP in ICCR to generate the stop condition.
This changes SDA from low to high when SCL is high, and generates the stop condition.

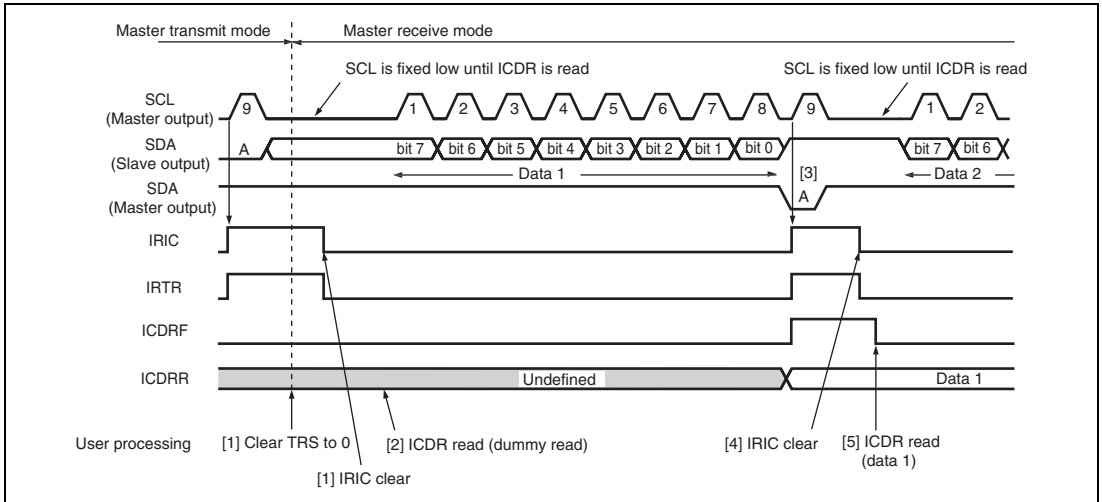

Figure 14.11 An Example of the Timing of Operations in Master Receive Mode (MLS = WAIT = 0, HNDS = 1)

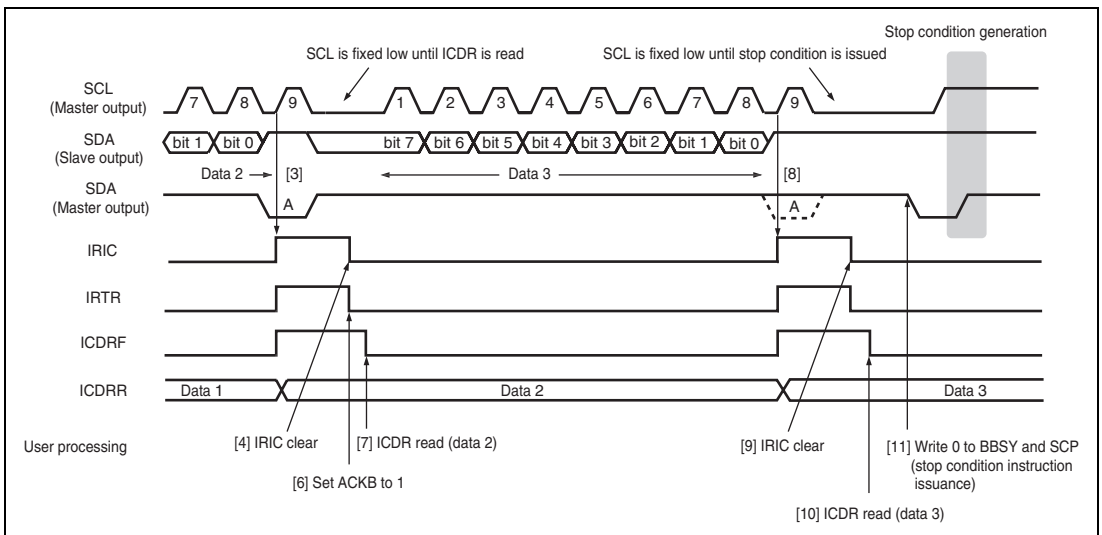

Figure 14.12 An Example of the Stop Condition Issuance Timing in Master Receive Mode (MLS = WAIT = 0, HNDS = 1)

Receive Operation with Wait:

Figure 14.13 and figure 14.14 are flowcharts that give examples of operations (WAIT = 1) in master receive mode.

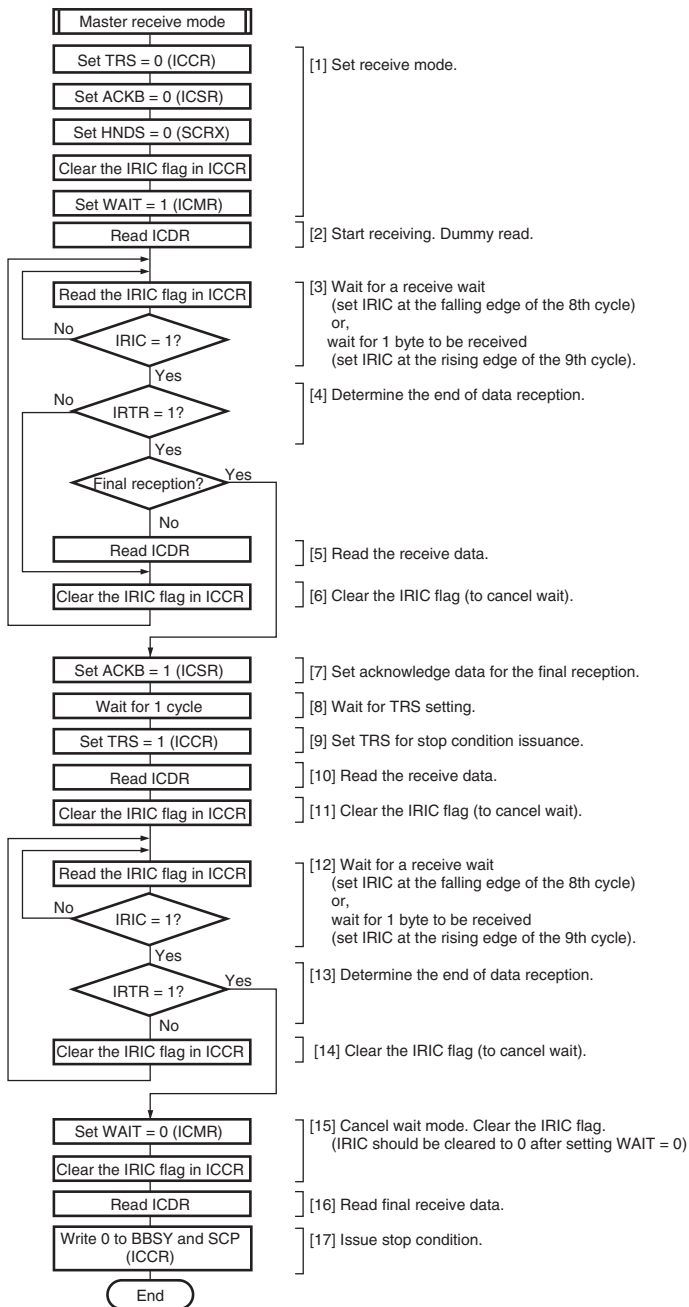

Figure 14.13 Example: Flowchart of Operations in Master Receive Mode (Multiple Bytes Reception) (WAIT = 1)

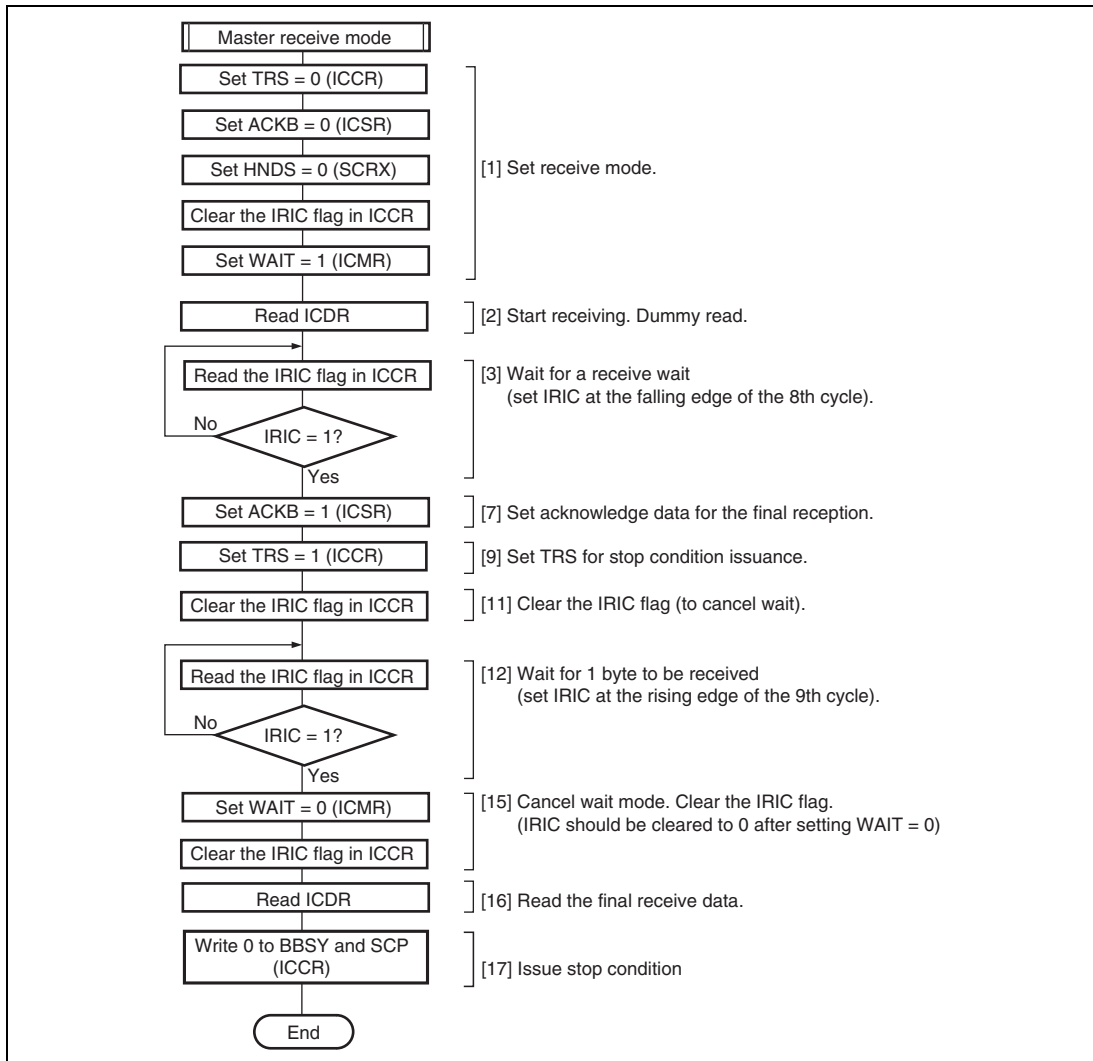

Figure 14.14 Example: Flowchart of Operations in Master Receive Mode (One Byte Reception) (WAIT = 1)

The following description gives the procedures to receive data serially in synchronization with ICDR (ICDRR) reading operation using wait operation (WAIT bit). The following description gives the procedures to receive multiple bytes. For the operation of receiving only one byte, see the flowchart in figure 14.14, since some procedures are omitted in the following description.

1. Clear the TRS bit in ICCR to 0 to change from the transmit mode to the receive mode.
Clear the ACKB bit in ICSR to 0 (setting of the acknowledge data).
Clear the HNDS bit in SCRX to 0 (canceling of the hand-shake function).
Clear the IRIC flag to 0, and then set the WAIT bit to 1.
2. When ICDR is read (a dummy read operation), the receiving of data starts; the receive clock is output in synchronization with the internal clock, and the first datum is then received.
3. The IRIC flag is set to 1 according to the following two. In this case, if the IEIC bit in ICCR is set to 1, an interrupt request is generated to the CPU.
 - A. The IRIC flag is set to 1 at the falling edge of the 8th cycle of one frame of the receive clock.
The SCL is automatically fixed low in synchronization with the internal clock until the IRIC flag is cleared.
 - B. The IRIC flag is set to 1 at the rising edge of the 9th cycle of one frame of the receive clock.
The IRTR and ICDRF flags are set to 1, indicating that one frame of data has been completely received. The master device continues outputting the receive clock for the next receive data.
4. Read the IRTR flag in ICSR.
When the IRTR flag is 0, cancel the wait operation by clearing the IRIC flag as described in step 6.
When the IRTR flag is 1 and the next data to be received is the final data, perform the end operation described in step 7.
5. When the IRTR flag is 1, read the receive data in ICDR.
6. Clear the IRIC flag to 0. In the case of step 3 A, the master device outputs the 9th cycle of the receive clock, drives the SDA to low, and returns acknowledgement.

Data can be received by repeating steps 3 to 6.

7. Set the ACKB bit in ICSR to 1 and set the acknowledge data for the final reception.
8. Wait for at least one cycle of clock and the first cycle of the next receive data rises since the IRIC flag is set to 1.
9. Change the mode from receive to transmit by setting the TRS bit in ICCR to 1. The set value of the TRS bit becomes valid after the rising edge of the 9th cycle of the clock is input.
10. Read the receive data in ICDR.

11. Clear the IRIC flag to 0.
12. The IRIC flag is set to 1 according to the following two conditions.
 - A. The IRIC flag is set to 1 at the falling edge of the 8th cycle of one frame of the receive clock.

SCL is automatically fixed low in synchronization with the internal clock until the IRIC flag is cleared.
 - B. The IRIC flag is set to 1 at the rising edge of the 9th cycle of one frame of the receive clock.

The IRTR and ICDRF flags are set to 1, indicating that one frame of data have been completely received. The master device continues outputting the receive clock for the next receive data.
13. Read the IRTR flag in ICSR.

When the IRTR flag is 0, cancel wait mode by clearing the IRIC flag as described in step 14.

When the IRTR flag is 1 and the receive operation has been completed, issue the stop condition as described in step 15.
14. When the IRTR flag is 0, clear the IRIC flag to 0 to cancel the wait operation.

To detect the completion of receive operation, go back to step 12 and read the IRIC flag.
15. Clear the WAIT bit in ICMR to 0 to cancel the wait mode, and then clear the IRIC flag to 0.

Clear the IRIC flag while WAIT is 0. (If the stop condition issuance instruction is executed by clearing the WAIT bit to 0 after clearing the IRIC flag to 0, the stop condition may not be output normally.)
16. Read the final receive data in ICDR.
17. Write BBSY = 0 and SCP = 0 to ICCR. When SCL is high, SDA is driven from low to high, and the stop condition is generated.

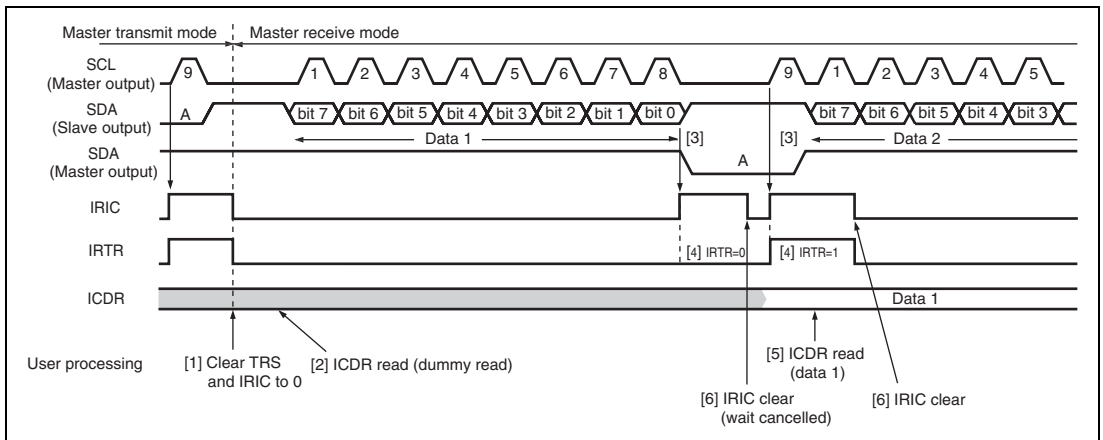

Figure 14.15 An Example of the Timing of Operations in Master Receive Mode
(MLS = ACKB = 0, WAIT = 1)

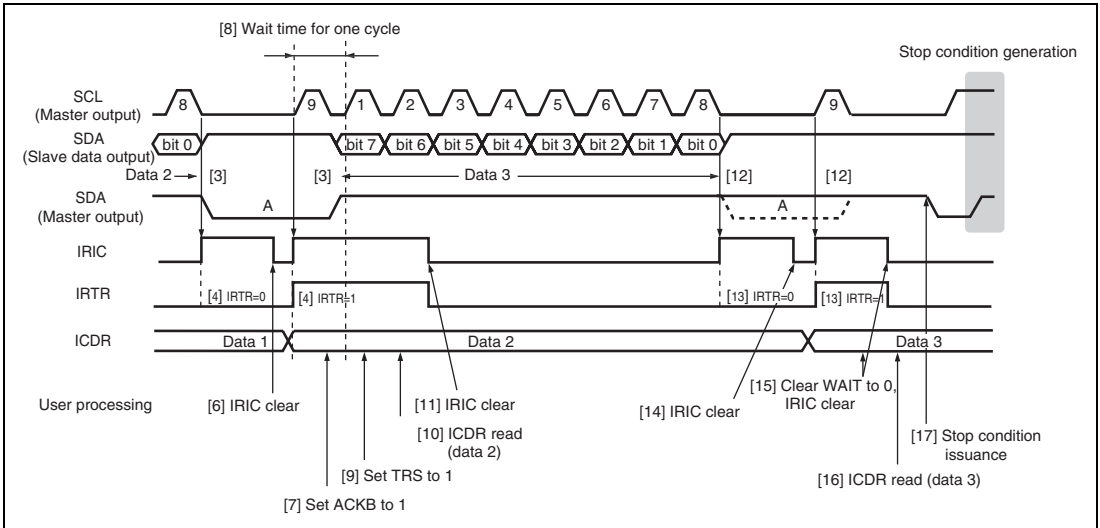

Figure 14.16 An Example of the Stop Condition Issuance Timing in Master Receive Mode (MLS = ACKB = 0, WAIT = 1)

14.4.5 Operations in Slave Reception

In the slave receive mode of the I²C bus format, the master device transmits the transmit clock and data, and the slave device returns acknowledgements of reception. The slave device compares the address of the slave address and the slave address of the first frame issued after the start condition issuance by the master device. If the addresses match, the slave device operates as a slave device specified by the master device.

Reception with HNDS Function (HNDS = 1):

Figure 14.17 is a flowchart that gives an example of operations in slave receive mode (HNDS = 1).

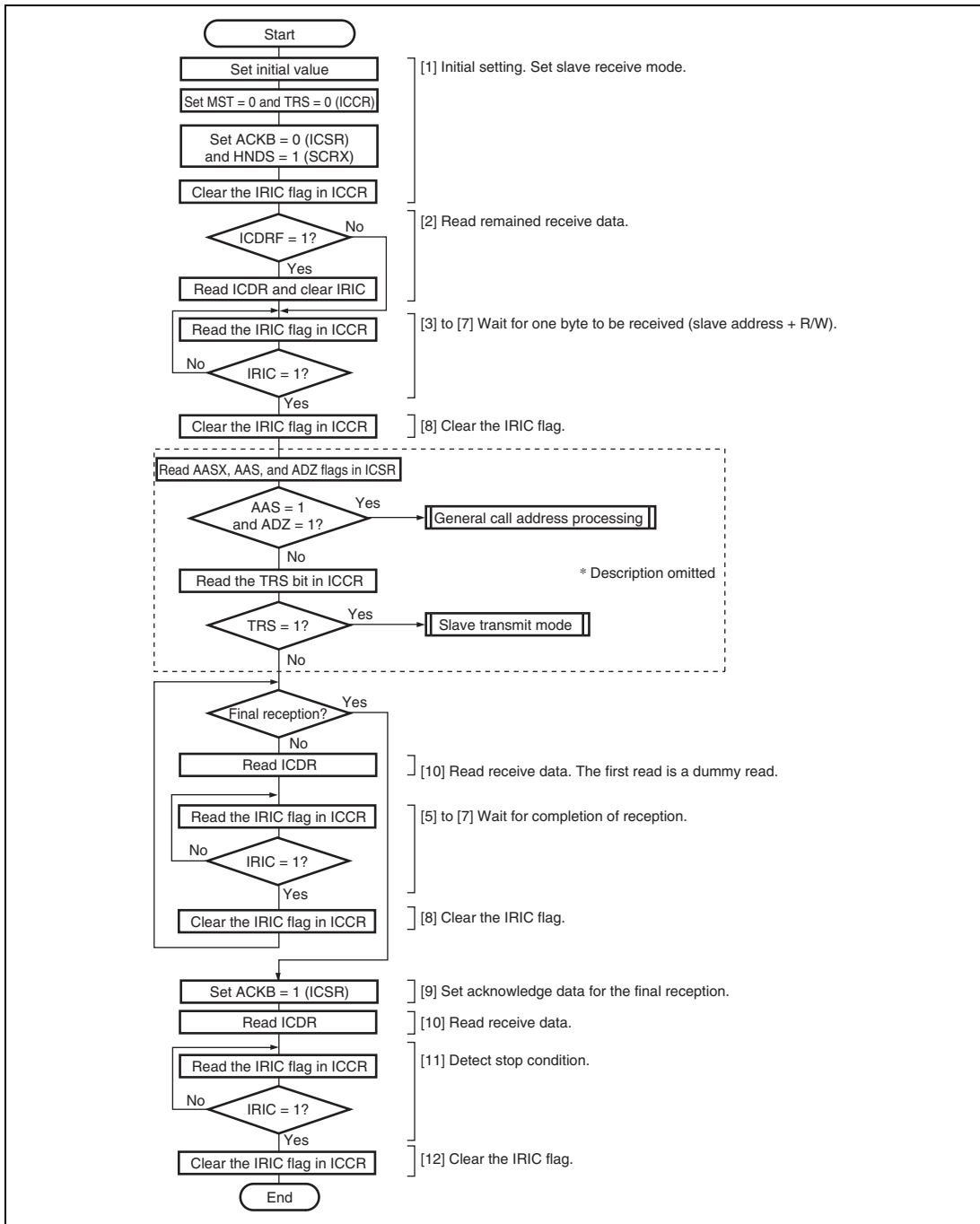

Figure 14.17 Example: Flowchart of Operations in the Slave Receive Mode (HNDS = 1)

The following description gives the procedures for and operations of receiving data in one byte units by fixing SCL low for every data reception using the HNDS bit function.

1. Perform initialization according to the procedure described in section 14.4.2, Initialization. Set slave receive mode by clearing the MST and TRS bits to 0. Set the HNDS bit to 1 and the ACKB bit to 0. To confirm the receive completion, clear the IRIC flag in ICCR to 0.
2. Confirm that the ICDRF flag is 0. If the ICDRF flag is set to 1, read ICDR and then clear the IRIC flag to 0.
3. When the start condition output by the master device is detected, the BBSY flag in ICCR is set to 1. The master device then outputs the 7-bit slave address and transmit/receive direction (R/\overline{W}) data in synchronization with the transmit clock pulses.
4. When the slave address matches the address in the first frame following the start condition generation, the slave device operates as the slave device specified by the master device. When the 8th bit of data (R/\overline{W}) is 0, the TRS bit remains 0 and slave receive operation is performed. When the 8th bit of data (R/\overline{W}) is 1, the TRS bit is set to 1 and slave transmit operation is performed.
When addresses do not match, data receive operation is not performed until the next start condition is detected.
5. The slave device returns the data set in the ACKB bit as an acknowledgement at the 9th cycle of the receive frame of the clock.
6. The IRIC flag is set to 1 at the 9th cycle of the clock. At this time, if the IEIC bit is set to 1, an interrupt request is generated for the CPU.
If the AASX bit is also set to 1, the IRTR flag is set to 1.
7. At the rising edge of the 9th cycle of the clock, the receive data is transferred from ICDRS to ICDRR and the ICDRF flag is set to 1. The slave device keeps SCL low from the falling edge of the 9th cycle of the receive clock until data in ICDR is read.
8. Confirm that the STOP bit is cleared to 0, and then clear the IRIC flag to 0.
9. When the next frame is the final receive frame, clear the ACKB bit to 1.
10. After ICDR has been read, the ICDRF flag is cleared to 0 and the SCL bus line is released. This enables master device to transfer the next data.

Receive operation can be continued by repeating steps 5 to 10.

11. After the stop condition (when SCL is high, the SDA is changed from low to high) is detected, the BBSY flag is cleared to 0 and the STOP bit is set to 1. At this time, if the STOPIM bit is cleared to 0, the IRIC flag is set to 1.
12. Confirm that the STOP bit is set to 1, and then clear the IRIC flag to 0.

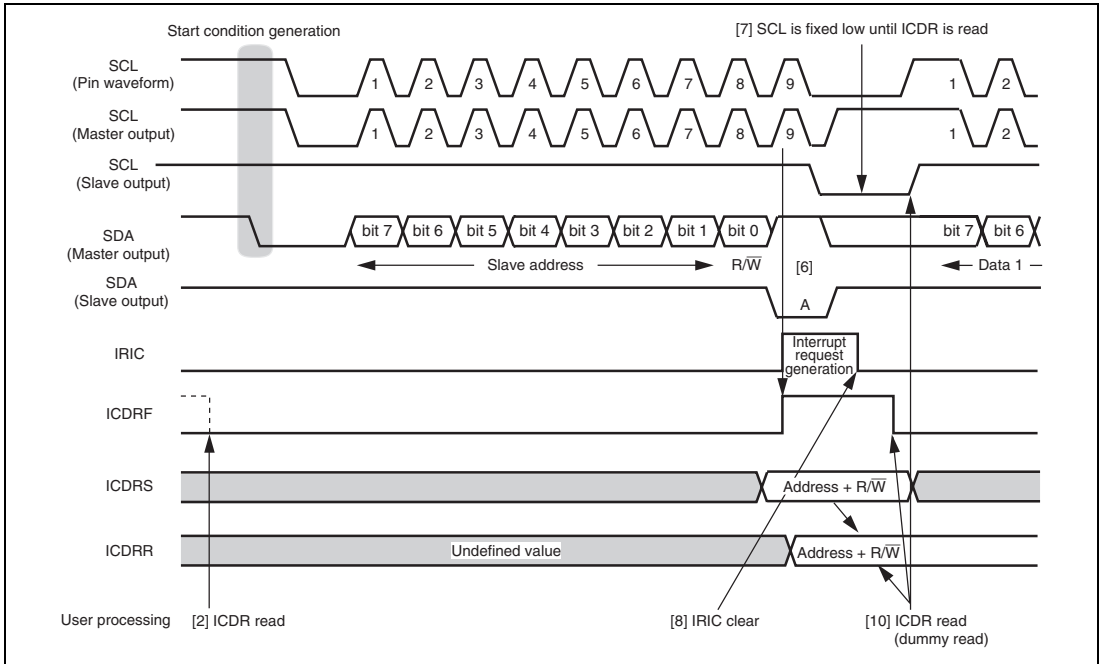

Figure 14.18 An Example of the Timing of Operations in Slave Receive Mode 1 (MLS = 0, HNDS = 1)

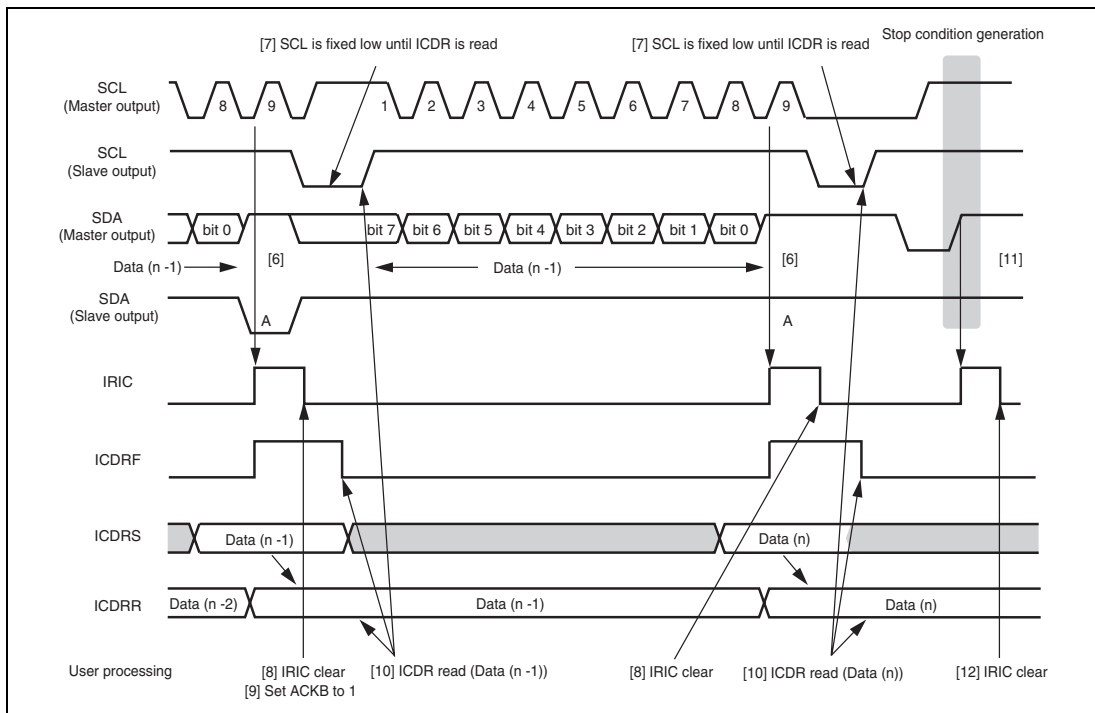

Figure 14.19 An Example of the Timing of Operations in Slave Receive Mode 2 (MLS = 0, HNDS = 1)

Continuous Receive Operation:

Figure 14.20 is a flowchart that gives an example of operations in slave receive mode (HNDS = 0).

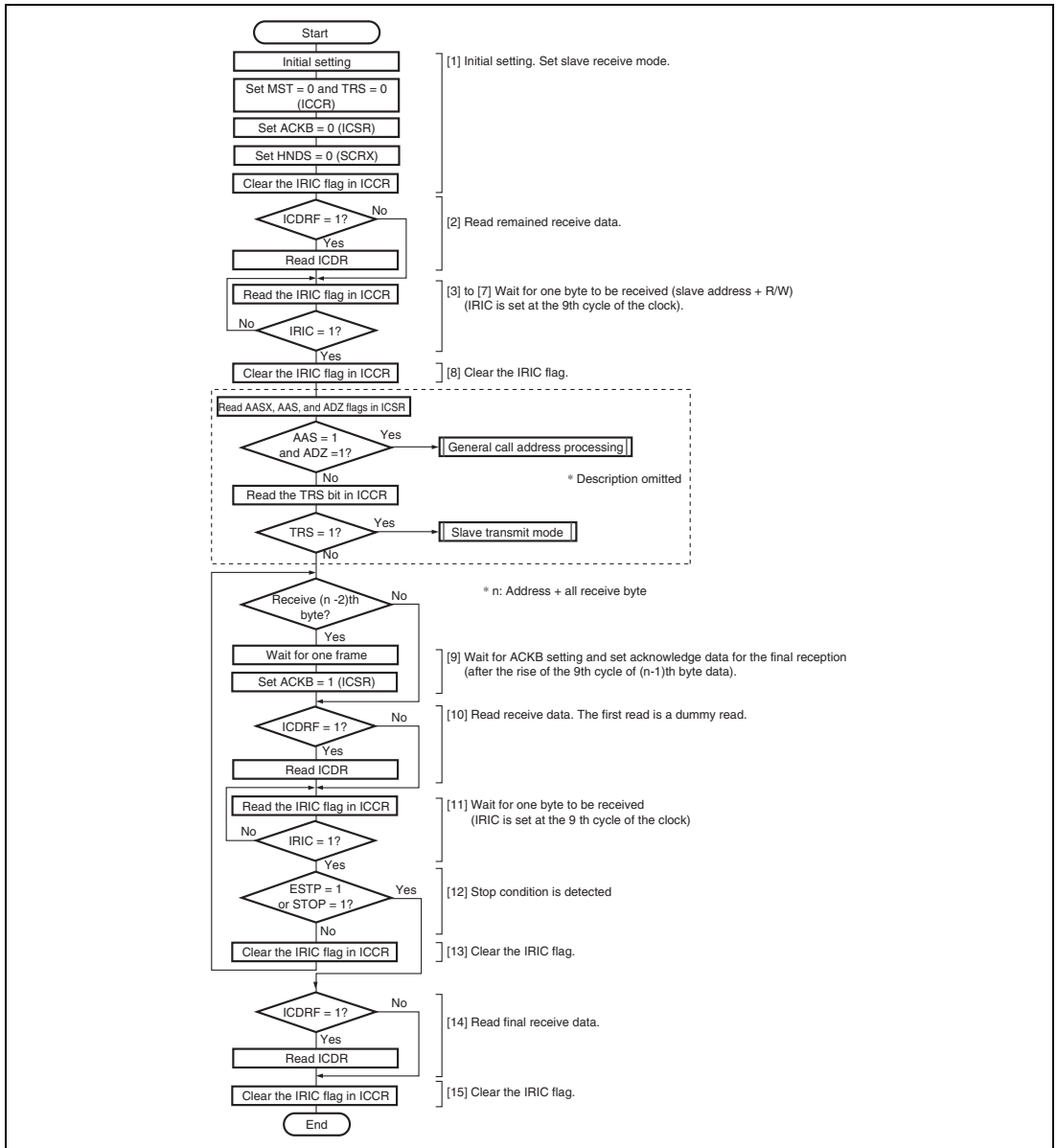

Figure 14.20 Example: Flowchart of Operations in Slave Transmit Mode (HNDS = 0)

The following description gives the procedures for and operations of receiving data in slave receive mode.

1. Perform initialization according to the procedure described in section 14.4.2, Initialization.
Set slave receive mode by clearing the MST and TRS bits to 0. Set the HNDS and ACKB bits to 0. To confirm the receive completion, clear the IRIC flag in ICCR to 0.
2. Confirm that the ICDRF flag is 0. If the ICDRF flag is set to 1, read ICDR and then clear the IRIC flag to 0.
3. When the start condition output by the master device is detected, the BBSY flag in ICCR is set to 1. The master device then outputs the 7-bit slave address and transmit/receive direction (R/\overline{W}) data in synchronization with the transmit clock pulses.
4. When the slave address matches the address in the first frame following the start condition generation, the slave device operates as the slave device specified by the master device. When the 8th bit of data (R/\overline{W}) is 0, the TRS bit remains 0 and slave receive operation is performed. When the 8th bit of data (R/\overline{W}) is 1, the TRS bit is set to 1 and slave transmit operation is performed.
When addresses do not match, data receive operation is not performed until the next start condition is detected.
5. The slave device returns the data set in the ACKB bit as an acknowledgement at the 9th cycle of the receive frame of the clock.
6. The IRIC flag is set to 1 at the 9th cycle of the clock. At this time, if the IEIC bit is set to 1, an interrupt request is generated for the CPU.
If the AASX bit is also set to 1, the IRTR flag is set to 1.
7. At the rising edge of the 9th cycle of the clock, the receive data is transferred from ICDRS to ICDRR and the ICDRF flag is set to 1.
8. Confirm that the STOP bit is cleared to 0, and then clear the IRIC flag to 0.
9. When the data to be read next is in two frames before the final receive frame, ensure at least one frame of wait time. Set the ACKB bit to 1 after the 9th cycle of the receive frame preceding the final receive frame.
10. Confirm that the ICDRF flag is set to 1, and then read ICDR.
After ICDR has been read, the ICDRF flag is cleared to 0.
11. If the receive data is transferred from ICDRS to ICDRR at the rising edge of the 9th cycle of the clock or ICDR read, IRIC and ICDRF flags are set to 1.
12. After the stop condition (when SCL is high, the SDA is changed from low to high) is detected, the BBSY flag is cleared to 0 and the STOP or ESTP flag is set to 1. At this time, if the STOPIM bit is cleared to 0, the IRIC flag is set to 1. In this case, read the final receive data as described in step 14.
13. Clear IRIC flag to 0.
Receive operation can be continued by repeating steps 9 to 13

14. Confirm that the ICDRF flag is set to 1, and then read ICDR.

15. Clear the IRIC flag to 0.

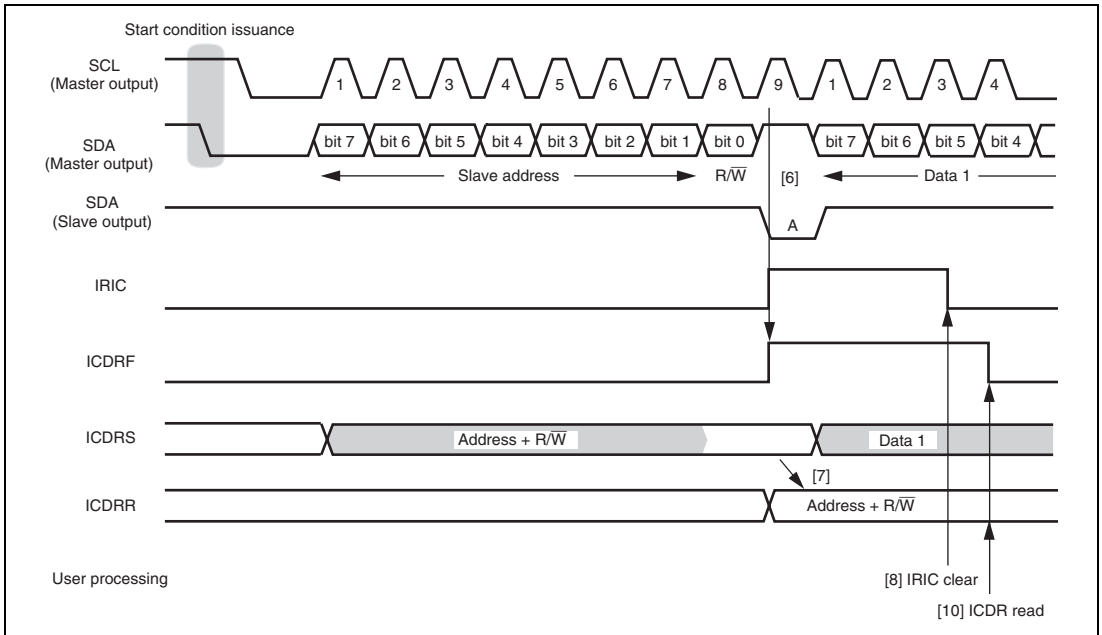
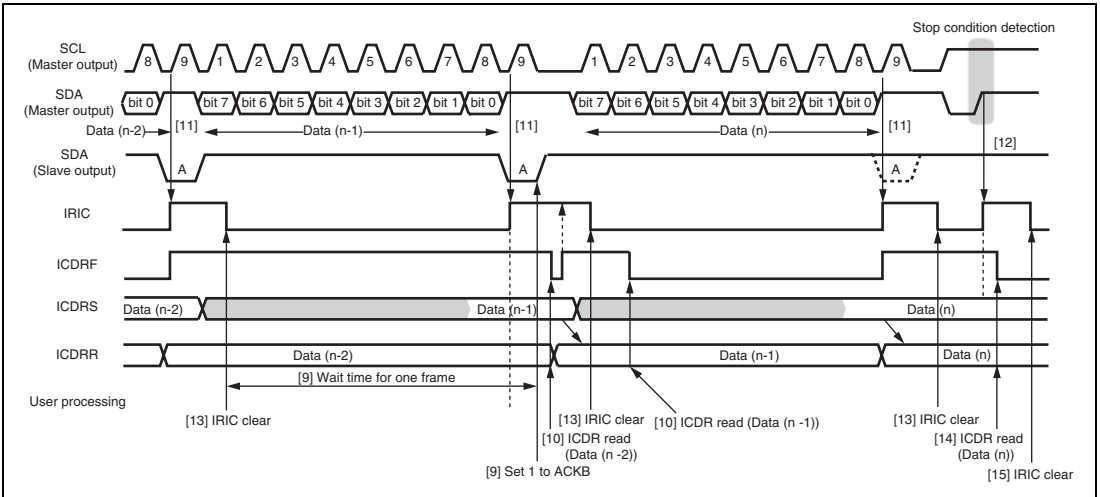

Figure 14.21 An Example of the Timing of Operations in Slave Receive Mode 1 (MLS = ACKB = 0, HNDS = 0)



**Figure 14.22 An Example of the Timing of Operations in Slave Receive Mode 2
(MLS = ACKB = 0, HNDS = 0)**

14.4.6 Operations in Slave Transmission

When the address of the slave device matches the address which the master device transfers in the first frame (address receive frame) after start condition detection in slave receive mode, and the 8th bit of data (R/ \bar{W}) is 1 (read), the TRS bit in ICCR is automatically set to 1 and slave transmit mode is entered.

Figure 14.23 is a flowchart that gives as example of operations in slave transmit mode.

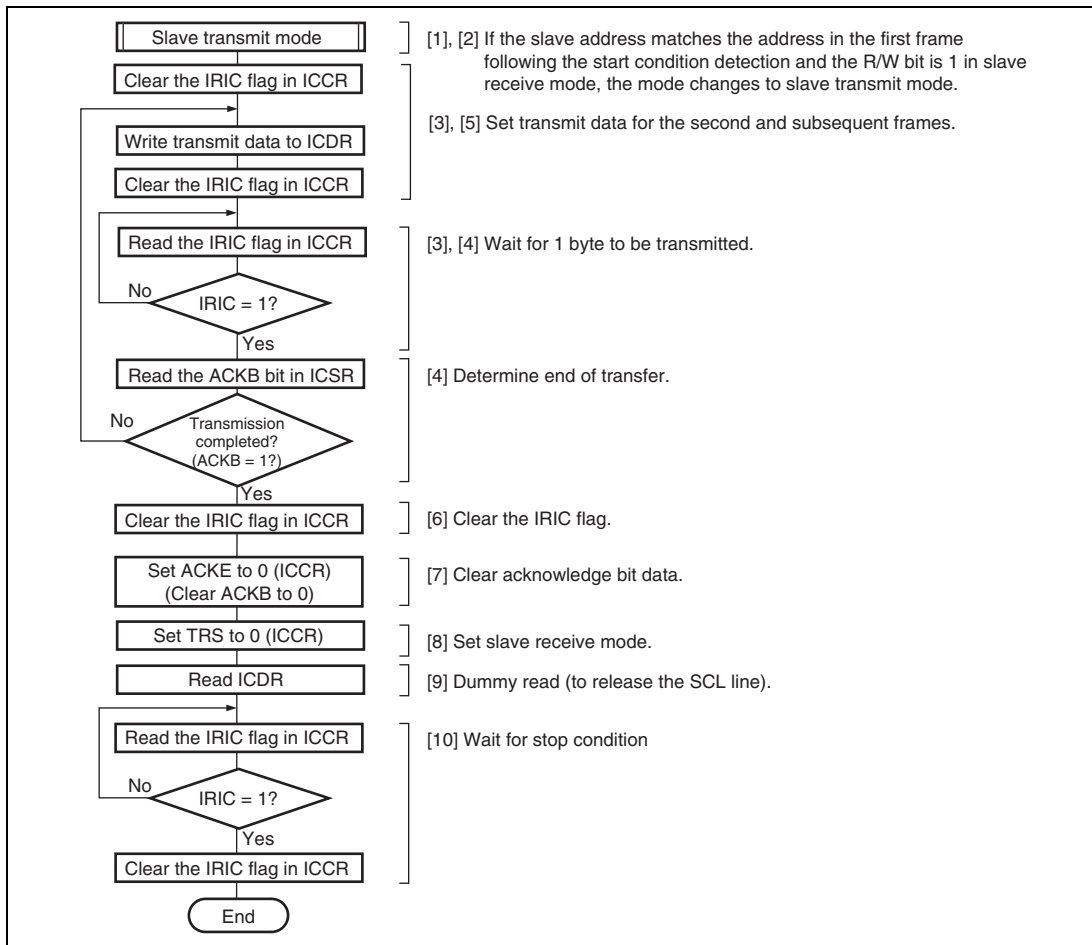

Figure 14.23 Example: Flowchart of Operations in Slave Transmit Mode

In the slave transmit mode, the slave device transmits data while the master device outputs the receive clock and returns acknowledgements of reception. The following description gives the procedures for and operations of transmitting in slave transmit mode.

1. Perform initialization of slave receive mode and wait for slave address reception.
2. When the slave address matches the address in the first frame following the start condition detection, the slave device drives SDA to low at the 9th cycle of the clock and returns acknowledgement. When the 8th bit of data (R/ \overline{W}) is 1, the TRS bit is set to 1 and slave transmit mode is automatically entered. The IRIC flag is set to 1 at the rising edge of the 9th cycle of the clock. At this time, if the IEIC bit is set to 1, an interrupt request is generated for the CPU. The ICDRE flag is set to 1. The slave device keeps SCL low to prevent the master device from outputting the next transmit clock from the falling edge of the 9th cycle of the transmit clock until data is written to ICDR.
3. After the IRIC flag is cleared to 0, the transmit data is written to ICDR. In this case, the ICDRE flag is cleared to 0. The written data is transferred to ICDRS, and the ICDRE and IRIC flags are again set to 1. The slave device sequentially transmits the data transferred to ICDRS, on the basis of the clock from the master device.
To detect the completion of transmission, clear the IRIC flag to 0. After writing the ICDR register, sequentially clear the IRIC flag so that no other process is inserted.
4. The master device drives SDA to low at the 9th cycle of the transfer frame and returns the acknowledgement. Since the acknowledgement is stored in the ACKB bit in ICSR, it can be checked whether transfer operation is performed normally. One frame of data transmission is completed and the IRIC flag is set to 1 at the rising edge of the 9th cycle of the transmit clock. When the ICDRE flag is 0, data written to the ICDR is transferred to ICDRS and one frame of data transmission is started, and then the ICDRE and IRIC flags are again set to 1. If the ICDRE flag is set to 1, SCL is kept low from the falling edge of the 9th cycle of the transmit clock until the data is written to the ICDR.
5. To continue with the transmission, write the next data for transmission to ICDR. In this case, the ICDRE flag is cleared to 0. To detect the completion of transmission, clear the IRIC flag to 0. Perform the ICDR register writing and the IRIC flag clearing sequentially so that no other process is inserted.

Transmission can be continued by repeating steps 4 and 5.

6. Clear the IRIC flag to 0.
7. To end the transmission, clear the ACKE bit in ICCR and the acknowledge bit stored in the ACKB bit to 0.
8. For the next address reception, clear the TRS bit to 0 and enter slave receive mode.
9. To release SDA on the slave side, dummy read ICDR.

10. When SCL is high and the stop condition is detected due to the change of SDA from low to high, the BBSY flag in ICCR is cleared to 0 and the STOP flag in ICSR is set to 1. When the STOPIM bit in ICXR is 0, the IRIC flag is set to 1. When the IRIC flag is set to 1, clear the flag to 0.

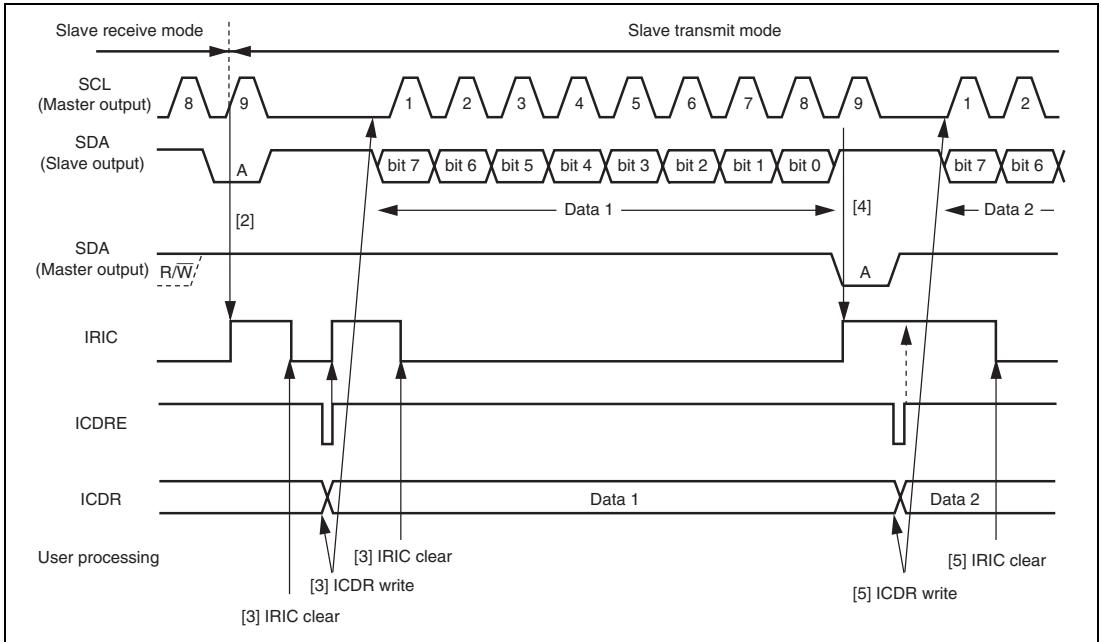

Figure 14.24 An Example of the Timing of Operations in Slave Transmit Mode (MLS = 0)

14.4.7 Timing for Setting IRIC and the Control of SCL

The timing with which the interrupt-request flag (IRIC) is set varies according to the settings of the WAIT bit in ICMR, FS bit in SAR, and the FSX bit in SARX. When the ICDRE and ICDRF flags are set to 1, the level on SCL is automatically set low in synchronization with the internal clock after the transfer of one frame of data. Figures 14.25 to 14.27 show the timing with which IRIC is set and the control of SCL.

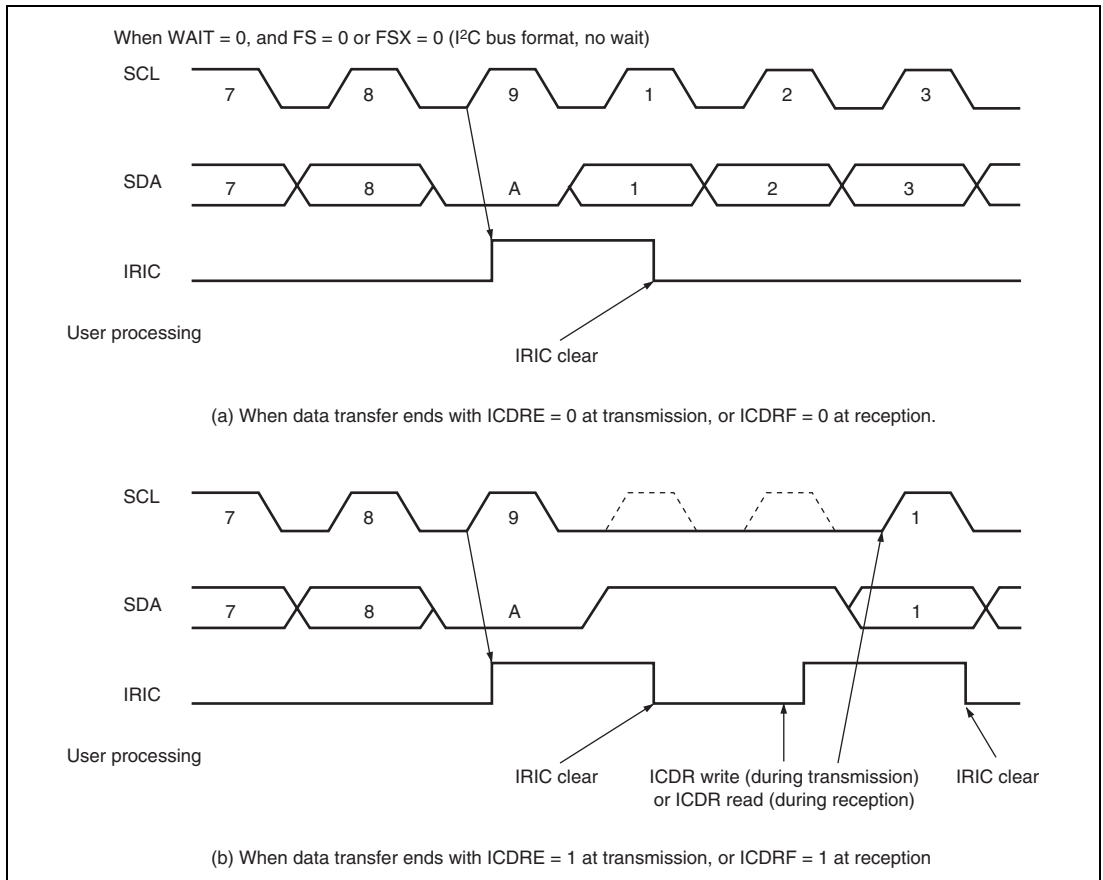
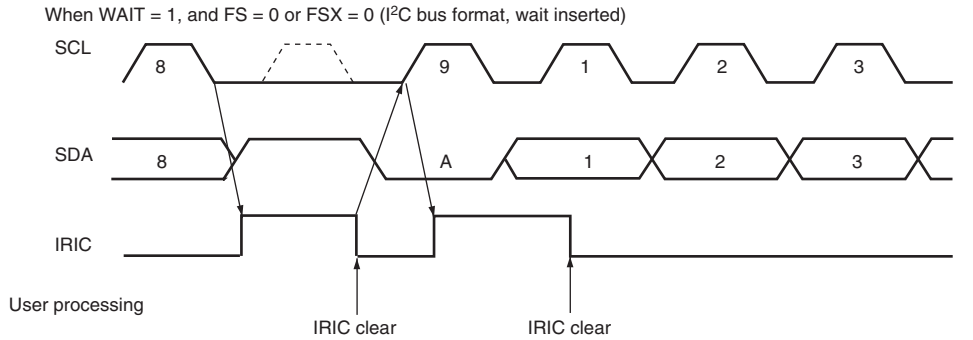
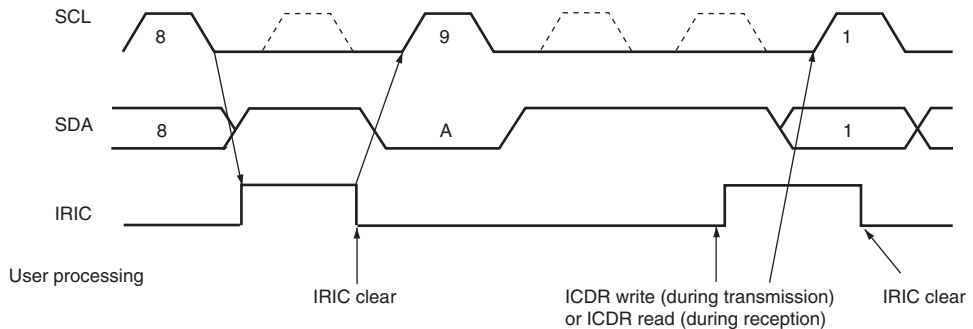

Figure 14.25 IRIC Flag Set Timing and the Control of SCL (1)



(a) When data transfer ends with ICDRE = 0 at transmission, or ICDRF = 0 at reception.



(b) When data transfer ends with ICDRE = 1 at transmission, or ICDRF = 1 at reception.

Figure 14.26 IRIC Flag Set Timing and the Control of SCL (2)

When FS = 1 and FSX = 1 (synchronous serial format)

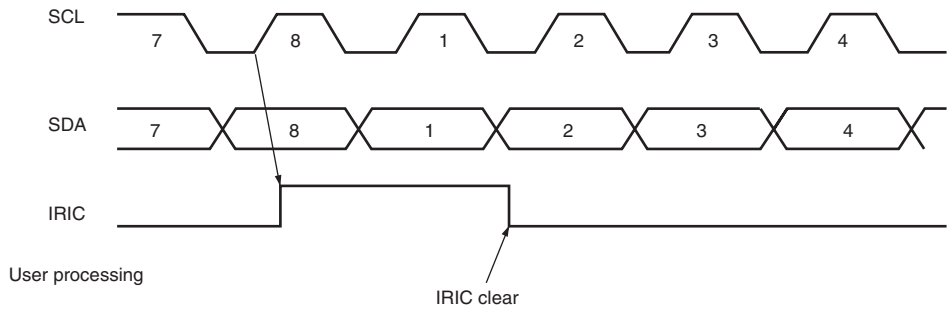

(a) When data transfer ends with ICDRE = 0 at transmission, or ICDRF = 0 at reception.

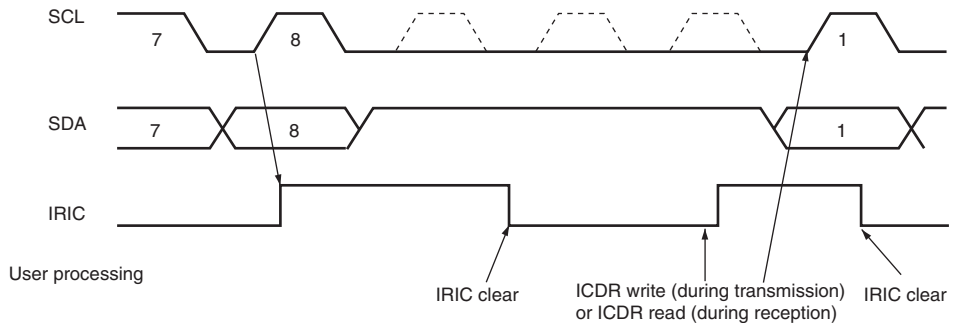

(b) When data transfer ends with ICDRE = 1 at transmission, or ICDRF = 1 at reception.

Figure 14.27 IRIC Flag Set Timing and the Control of SCL (3)

14.4.8 DTC Operation

This LSI provides the DTC to allow continuous data transfer. The DTC is initiated when the IRTR flag is set to 1, which is one of the two interrupt flags (IRIC and IRTR). When the ACKE bit is 0, the ICDRE, IRIC, and IRTR flags are set at the end of data transmission regardless of the acknowledge bit value. When the ACKE bit is 1, the ICDRE, IRIC, and IRTR flags are set if data transmission is completed with the acknowledge bit value of 0, or only the IRIC flag is set if data transmission is completed with the acknowledge bit value of 1.

When initiated, DTC transfers specified number of bytes, clears the ICDRE, IRIC, and IRTR flags to 0. Therefore, no interrupt is generated during continuous data transfer; however, if data transmission is completed with the acknowledge bit value of 1 when the ACKE bit is 1, DTC is not initiated, thus allowing an interrupt to be generated if enabled.

The acknowledge bit may indicate specific events such as completion of receive processing for some receiving device, and for other receiving device, the acknowledge bit may be held to 1, indicating no specific event.

In the I²C bus format, since the slave device or the direction of transfer is selected by the slave address or the R/ \bar{W} bit, and the acknowledge bit may indicate the end of reception or reception of the final frame, the continuous transfer of data by the DTC must be combined with interrupt-driven processing by the CPU.

Table 14.7 shows examples of processes in which the DTC is used. For the slave-mode processes, it is assumed that the amount of data to be transferred is defined in advance.

Table 14.7 Examples of Operations in which the DTC Is Used

| Item | Master Transmit Mode | Master Receive Mode | Slave Transmit Mode | Slave Receive Mode |
|---|--|---|--|---|
| Slave address + R/W bit transmission/reception | DTC transmission (ICDR write) | CPU transmission (ICDR write) | CPU reception (ICDR read) | CPU reception (ICDR read) |
| Dummy data read | — | CPU processing (ICDR read) | — | — |
| Main unit data transmission/reception | DTC transmission (ICDR write) | DTC reception (ICDR read) | DTC transmission (ICDR write) | DTC reception (ICDR read) |
| Final frame processing | Unnecessary | CPU reception (ICDR read) | Unnecessary | CPU reception (ICDR read) |
| Setting the number of frames of data to be transferred in DTC | Transmission: Number of actual frames of data + 1 (+1 represents the frame for slave address + R/W bits) | Reception: Number of actual frames of data | Transmission: Number of actual frames of data | Reception: Number of actual frames of data |

14.4.9 Noise Canceller

The states on the SCL and SDA pins are fetched internally via the noise canceller. Figure 14.28 is a block diagram of the noise canceller.

The noise canceller consists of a 2-stage latch circuit and match-detection circuit, which are connected in series. The input signal on the SCL pin (or on the SDA pin) is sampled on the system clock; when the two latch outputs match, the given level is then sent to the next stage. If the two values do not match, the existing value is maintained.

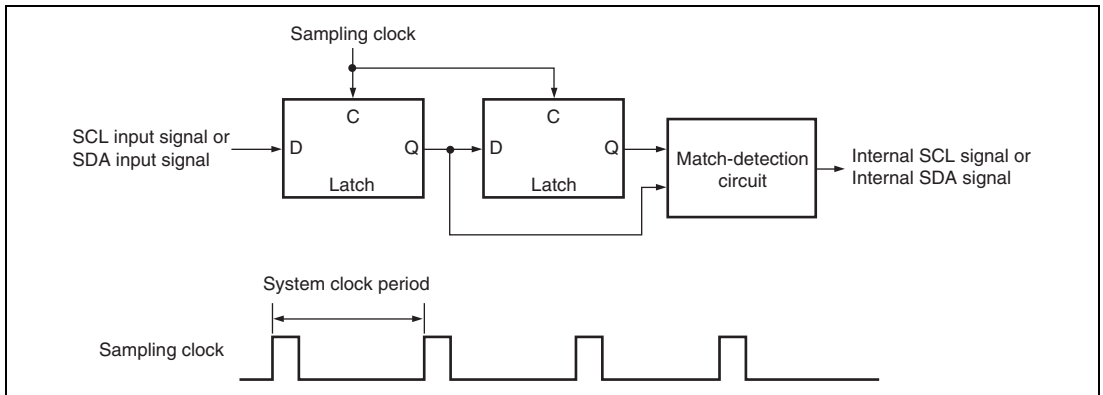

Figure 14.28 Block Diagram of the Noise Canceller

14.4.10 Initialization of Internal State

This IIC module has a function for forcible initialization of its internal state if a deadlock occurs during communication.

Initialization is executed by clearing ICE bit.

Scope of Initialization:

The initialization executed by this function covers the following items:

- ICDRE and ICDRF internal flags
- Transmit/receive sequencer and internal operating clock counter
- Internal latches for retaining the output state of the SCL and SDA pins (wait, clock, data output, etc.)

The following items are not initialized:

- Actual register values (ICDR, SAR, SARX, ICMR, ICCR, ICSR, SCRX (except for the ICDRE and ICDRF flags))
- Internal latches used to retain register read information for setting/clearing flags in the ICMR, ICCR, and ICSR registers
- The value of the ICMR register bit counter (BC2 to BC0)
- Generated interrupt sources (interrupt sources transferred to the interrupt controller)

Notes on Initialization:

- Interrupt flags and interrupt sources are not cleared; therefore, flag clearing measures must be taken as necessary.
- Basically, other register flags are not cleared either; therefore, flag clearing measures must be taken as necessary.
- If a flag clearing setting is made during transmission/reception, the IIC module will stop transmitting/receiving at that point and the SCL and SDA pins will be released. When transmission/reception is started again, register initialization, etc., must be carried out as necessary to enable correct communication as a system.

The value of the BBSY bit cannot be modified directly by this module clear function, but since pin waveforms with stop condition may be generated depending on the state and release timing of the SCL and SDA pins, causing the BBSY bit to be cleared. Similarly, switching of the state may influence other bits and flags.

To prevent problems caused by these factors, the following procedure should be used when initializing the IIC state.

1. Execute initialization of the internal state by clearing the ICE bit.
2. Execute a stop condition issue instruction (write 0 to BBSY and SCP) to clear the BBSY bit to 0, and wait for two transfer rate clock cycles.
3. Re-execute initialization of the internal state by clearing the ICE bit.
4. Initialize (reset) the IIC registers.

14.5 Usage Notes

- In master mode, when the instruction that generates the start condition is issued immediately after the instruction that generates the stop condition, neither the start condition nor the stop condition will be correctly output. For the consecutive output of the start condition and stop condition, read the port after issuing the instruction that generates the start condition, and make sure that the levels on both SCL and SDA are low. Then issue the instruction that generates the stop condition. Note that SCL may not have completely reached its low level when BBSY becomes 1.
- The following two conditions apply to the start of the next transfer: take note when reading from/writing to ICDR.
 - ICE = 1, TRS = 1, and data is written to ICDR (including automatic transfer from ICDRT to ICDRS)
 - ICE = 1, TRS = 0, and data is read from ICDR (including automatic transfer from ICDRS to ICDRR)
- In synchronization with the internal clock, SCL and SDA are output with the timing shown in table 14.8. The timing on the bus is determined by the rise/fall times of the signals, and these are affected by the bus-load's capacitance, series resistance, and parallel resistance.

Table 14.8 I²C Bus Timing (output of SCL and SDA)

| Item | Symbol | Output Timing | Unit | Remarks |
|--|--------------------|---|------|---------|
| SCL-output cycle time | t_{SCLO} | 28 $t_{\text{p}yc}$ to 256 $t_{\text{p}yc}$ | ns | |
| SCL-output high-pulse width | t_{SCLHO} | 0.5 t_{SCLO} | ns | |
| SCL-output low-pulse width | t_{SCLLO} | 0.5 t_{SCLO} | ns | |
| SDA-output bus-free time | t_{BUFO} | 0.5 t_{SCLO} - 1 $t_{\text{p}yc}$ | ns | |
| Start-condition-output hold time | t_{STAHO} | 0.5 t_{SCLO} - 1 $t_{\text{p}yc}$ | ns | |
| Output setup time for re-transmission of start condition | t_{STASO} | 1 t_{SCLO} | ns | |
| Setup time for output of the stop condition | t_{STOSO} | 0.5 t_{SCLO} + 2 $t_{\text{p}yc}$ | ns | |
| Setup time for the output of data (master) | t_{SDASO} | 1 t_{SCLLO} - 3 $t_{\text{p}yc}$ | ns | |
| Setup time for the output of data (slave) | | 1 t_{SCLL} - (6 $t_{\text{p}yc}$ or 12 $t_{\text{p}yc}$ *) | ns | |
| Data-output hold time | t_{SDAHO} | 3 $t_{\text{p}yc}$ | ns | |

Note: * When the IICX is 0, 6 $t_{\text{p}yc}$. When IICX is 1, 12 $t_{\text{p}yc}$.

4. The SCL and SDA inputs are sampled in synchronization with P ϕ . Therefore, the AC timing depends on the period of P ϕ cycle t_{pcyc} . When the P ϕ frequency does not reach 5 MHz, the AC timing specifications of the I²C bus interface are not satisfied.
5. The SCL rising time t_{sr} is defined as being within 1,000 ns (300 ns in the high-speed mode). The I²C bus interface monitors SCL in the master mode, and communication is synchronized in a bit-by-bit basis. When the rise time t_{sr} (the time required to reach V_{IH} from an initially low level) of SCL exceeds the time determined by the input clock of the I²C bus interface, the high-level period of SCL is extended. The time SCL takes to rise is determined by the pull-up resistance and the load capacitance. Therefore, to operate at the specified transfer rate, set the pull-up resistance and load capacitance so that each time is within the corresponding value given in table 14.9.

Table 14.9 Tolerance of the SCL Rise Time (t_{sr})

| IICX | t_{pcyc} | I ² C bus specification (Max.) | Time [ns] | | | | | | |
|------|------------------------|---|------------------|------------------|------------------|------------------|------------------|------------------|-----|
| | | | P ϕ = 10MHz | P ϕ = 16MHz | P ϕ = 20MHz | P ϕ = 25MHz | P ϕ = 33MHz | P ϕ = 40MHz | |
| 0 | 7.5 t_{pcyc} | Standard mode | 1000 | 750 | 468 | 375 | 300 | 227 | 188 |
| | | High-speed mode | 300 | ← | ← | ← | ← | 227 | 188 |
| 1 | 17.5 t_{pcyc} | Standard mode | 1000 | ← | ← | 875 | 700 | 530 | 438 |
| | | High-speed mode | 300 | ← | ← | ← | ← | ← | ← |

6. The rise and fall times of SCL and SDA are respectively prescribed as being 1000 ns or less and 300 ns or less by the I²C bus specification. The output timing of SCL and SDA for the I²C bus interface of this LSI are described by t_{pcyc} as shown in table 14.8. However, due to the effect of the rise and fall times, the I²C bus interface specifications may not be satisfied at the maximum transfer rate. Table 14.10 shows the results of calculating the output timing for each available operating frequency, by considering the worst-case rise and fall times. t_{BUFO} does not satisfy the specifications of the I²C bus interface specifications. Take either of the following countermeasures against this problem:
 - A. Ensure that your program provides the required interval (approximately 1 μ s) between issuing of the stop condition and of the next start condition.
 - B. Select a slave device with an input timing that permits use with this output timing for connection to the I²C bus.

For t_{SCLLO} in high-speed mode and t_{STASO} in standard mode, the I²C bus interface specification is not satisfied when the worst case for t_{sr}/t_{sf} is assumed. Take one of the following steps:

- A. Adjust the rise and fall times by changing the pull-up resistors and load capacitance.
- B. Reduce the transfer rate until the specification is satisfied.
- C. For connection to the I²C bus, select a slave device with an input timing that permits use with this output timing.

Table 14.10 I²C Bus Timing (when the effect of t_{Sr}/t_{Sf} is at its maximum)

| Item | $t_{p\text{cyc}}$ | | Time (at Maximum Transfer Rate) [ns] | | | | | | | |
|--------------------------|--|-----------------|--------------------------------------|--|--------------------|--------------------|--------------------|--------------------|--------------------|--------------------|
| | | | Effect of t_{Sr}/t_{Sf} (max) | I ² C bus specification (min) | P ϕ = 10MHz | P ϕ = 16MHz | P ϕ = 20MHz | P ϕ = 25MHz | P ϕ = 33MHz | P ϕ = 40MHz |
| t_{SCLHO} | $0.5 t_{SCLO}$ ($-t_{Sr}$) | Standard mode | -1000 | 4000 | 4000 | 4000 | 4000 | 4000 | 4000 | 4000 |
| | | High-speed mode | -300 | 600 | 950 | 950 | 950 | 950 | 950 | 950 |
| t_{SCLLO} | $0.5 t_{SCLO}$ ($-t_{Sr}$) | Standard mode | -250 | 4700 | 4750 | 4750 | 4750 | 4750 | 4750 | 4750 |
| | | High-speed mode | -250 | 1300 | 1000* ¹ | 1000* ¹ | 1000* ¹ | 1000* ¹ | 1000* ¹ | 1000* ¹ |
| t_{BUFO} | $0.5 t_{SCLO} - 1 t_{p\text{cyc}}$ ($-t_{Sr}$) | Standard mode | -1000 | 4700 | 3900* ¹ | 3938* ¹ | 3950* ¹ | 3960* ¹ | 3970* ¹ | 3975* ¹ |
| | | High-speed mode | -300 | 1300 | 850* ¹ | 888* ¹ | 900* ¹ | 910* ¹ | 920* ¹ | 925* ¹ |
| t_{STAHO} | $0.5 t_{SCLO} - 1 t_{p\text{cyc}}$ ($-t_{Sr}$) | Standard mode | -250 | 4000 | 4650 | 4688 | 4700 | 4710 | 4720 | 4725 |
| | | High-speed mode | -250 | 600 | 900 | 938 | 950 | 960 | 970 | 975 |
| t_{STASO} | $1 t_{SCLO}$ ($-t_{Sr}$) | Standard mode | -1000 | 4700 | 9000 | 9000 | 9000 | 9000 | 9000 | 9000 |
| | | High-speed mode | -300 | 600 | 2200 | 2200 | 2200 | 2200 | 2200 | 2200 |
| t_{STOSO} | $0.5 t_{SCLO} + 2 t_{p\text{cyc}}$ ($-t_{Sr}$) | Standard mode | -1000 | 4000 | 4200 | 4125 | 4100 | 4080 | 4061 | 4050 |
| | | High-speed mode | -300 | 600 | 1150 | 1075 | 1050 | 1030 | 1011 | 1000 |
| t_{SDASO} As master | $1 t_{SCLLO}^{*3} - 3 t_{p\text{cyc}}$ ($-t_{Sr}$) | Standard mode | -1000 | 250 | 3400 | 3513 | 3550 | 3580 | 3609 | 3625 |
| | | High-speed mode | -300 | 100 | 700 | 813 | 850 | 880 | 909 | 925 |
| t_{SDASO} As slave | $1 t_{SCLL}^{*3} - 12 t_{p\text{cyc}}^{*2}$ ($-t_{Sr}$) | Standard mode | -1000 | 250 | 2500 | 2950 | 3100 | 3220 | 3336 | 3400 |
| | | High-speed mode | -300 | 100 | -200* ¹ | 250 | 400 | 520 | 636 | 700 |
| t_{SDAHO} | $3 t_{p\text{cyc}}$ | Standard mode | 0 | 0 | 300 | 188 | 150 | 120 | 91 | 75 |
| | | High-speed mode | 0 | 0 | 300 | 188 | 150 | 120 | 91 | 75 |

Notes: 1. Apply one or more of the following measures to satisfy the I²C bus interface specification.

- Ensure that the interval between the setting of the start condition and of the stop condition is sufficient.
- Adjust the rise and fall times by changing the values of the pull-up resistors and load capacitance.
- Adjust the system by decreasing the transfer rate.
- Select a slave device with an input timing that permits the I/O timing.

The values in the above table are changed by the setting of the IICX bit and the CKS2 to CKS0 bits. Since the maximum transfer rate may not be achievable, depending on the frequency, check whether or not the I²C bus interface specification is satisfied under the actual conditions that are set.

2. When the IICX bit is 1. When the IICX bit is 0, ($t_{SCLL} - 6t_{PcyC}$).
3. Calculated from the I²C bus specifications (standard 4700 ns/min, high-speed: 1300 ns/min.)

7. Points for caution when reading ICDR at the end of master reception

To halt the reception of data after a receive operation in the master receive mode has been completed, set the TRS bit to 1 and write 0 to BBSY and SCP. By doing so, the level on SDA will be changed from low to high while SCL is high, that is, the stop condition will be generated. The received data can be read by reading ICDR. If there is data in the buffer, however, the data received in ICDRS cannot be transferred to ICDR (ICDRR). Therefore, the second-byte of data cannot be read.

When reading of the second-byte of data is required, set the stop condition in the master receive mode (with the TRS bit being 0). When reading the received data, confirm that the BBSY bit in ICCR is 0, the stop condition has been generated, and the bus is released. After that, read the ICDR register while TRS is 0.

In this case, if an attempt is made to read the received data (data in ICDR) during the period from the execution of the instruction (write 0 to BBSY and SCP of ICCR) that sets the stop condition and the actual generation of the stop condition, it is not possible to generate the clock correctly for a the subsequent master transmission.

Rewriting of the I²C control bit to change the mode of operation or setting of transmission/reception, such as clearing of the MST bit after the completion of transmission/reception by the master, must not take place in any period other than period (a) (after confirming that the BBSY bit in ICCR has been cleared to 0) in figure 14.29.

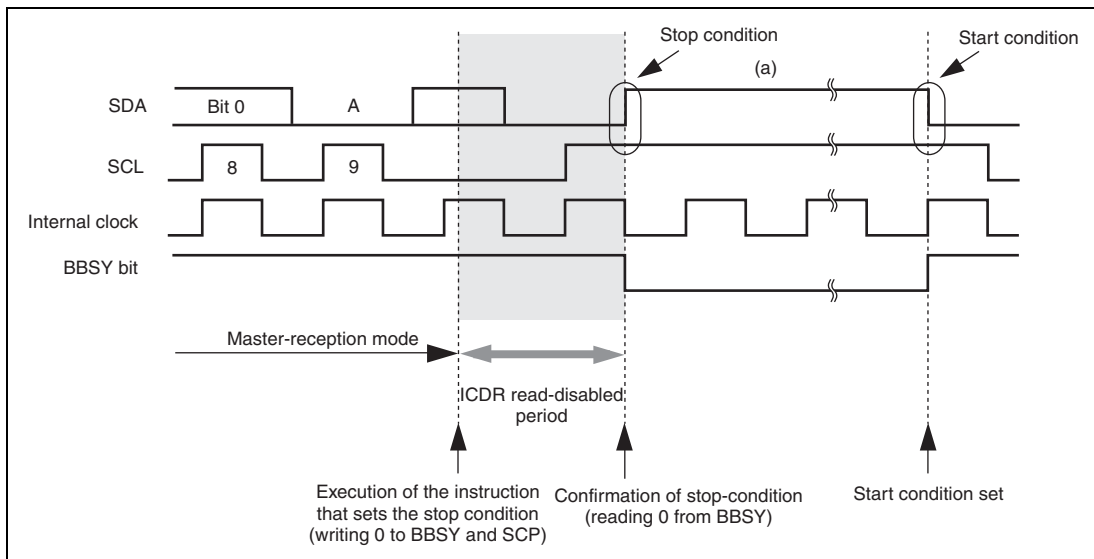

Figure 14.29 Points for Caution in Reading Data Received by Master Reception

8. Points for Caution in Setting the Start Condition for Re-transmission

Figure 14.30 shows the timing and flowchart of the setting of the start condition for re-transmission, and the timing with which the data is continuously written to ICDR. Write the transmit data to ICDR after the start condition for re-transmission is issued and then the start condition is actually generated.

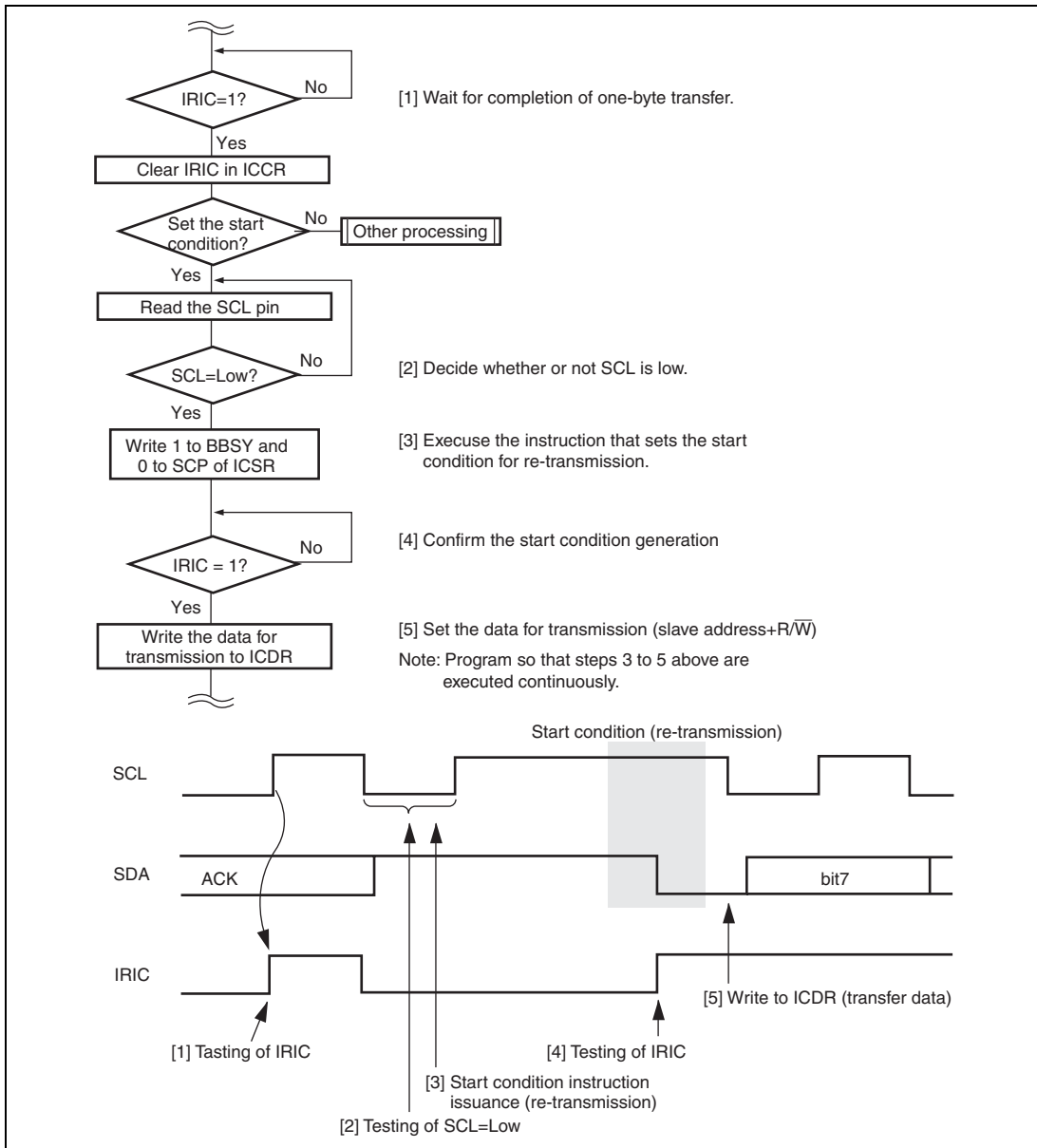

Figure 14.30 Flowchart and Timing of the Execution of the Instruction that Sets the Start Condition for Re-Transmission

9. Points for caution in the execution of the instruction that sets the I²C bus interface stop condition

If the rise time in the 9th cycle of SCL exceeds the specified value due to a high bus-load capacitance, or if a slave device inserts a wait by setting the level on SCL low, read SCL after the rise of 9th cycle of the clock to confirm that the level is low, and then execute the instruction that sets the stop condition.

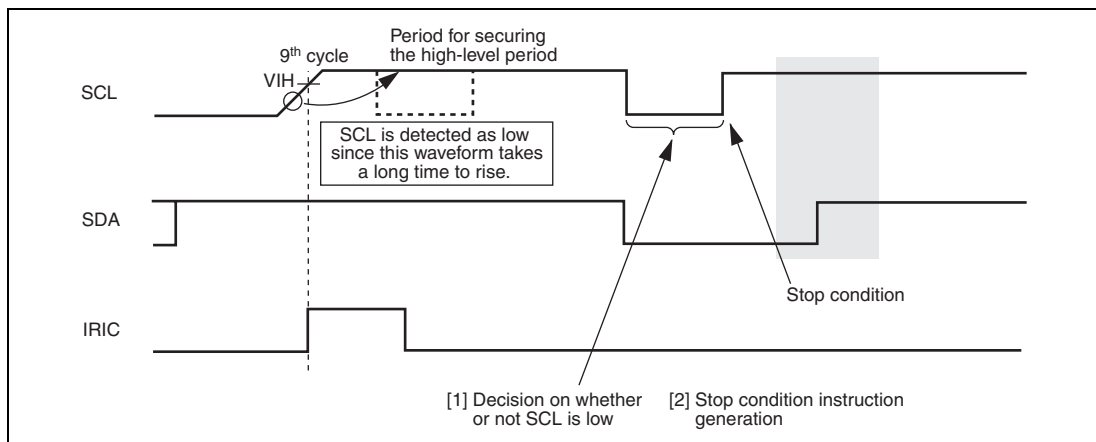

Figure 14.31 Timing for the Setting of the Stop Condition

10. Notes on WAIT function

— Conditions to cause this phenomenon

When both of the following conditions are satisfied, the clock pulse of the 9th clock could be outputted continuously in master mode using the WAIT function due to the failure of the WAIT insertion after the 8th clock fall.

- (1) Setting the WAIT bit of the ICMR register to 1 and operating WAIT, in master mode
- (2) If the IRIC bit of interrupt flag is cleared from 1 to 0 between the fall of the 7th clock and the fall of the 8th clock.

— Error phenomenon

Normally, WAIT State will be cancelled by clearing the IRIC flag bit from 1 to 0 after the fall of the 8th clock in WAIT State. In this case, if the IRIC flag bit is cleared between the 7th clock fall and the 8th clock fall, the IRIC flag clear-data will be retained internally. Therefore, the WAIT State will be cancelled right after WAIT insertion on 8th clock fall.

— Restrictions

Please clear the IRIC flag before the rise of the 7th clock (the counter value of BC2 through BC0 should be 2 or greater), after the IRIC flag is set to 1 on the rise of the 9th clock.

If the IRIC flag-clear is delayed due to the interrupt or other processes and the value of BC counter is turned to 1 or 0, please confirm the SCL pins are in L' state after the counter value of BC2 through BC0 is turned to 0, and clear the IRIC flag. (See figure 14.32.)

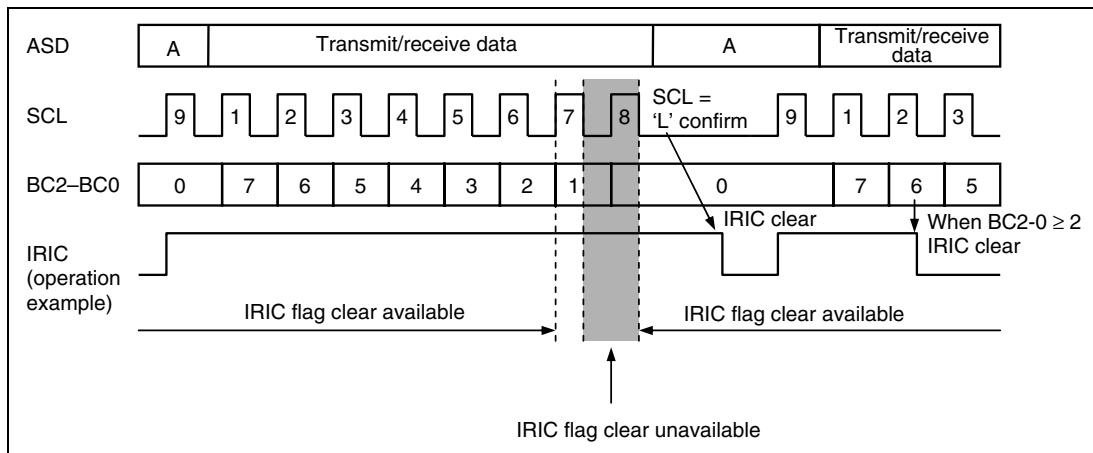

Figure 14.32 IRIC Flag Clear Timing on WAIT Operation

11. Points for caution of clearing the IRIC flag when the wait function is used

While the wait function is used in I²C bus interface master mode, if the rise time of SCL exceeds the specified value or if a slave device in which a wait can be inserted by driving SCL low is used, read SCL in the following way to confirm that SCL has become low, and then clear the IRIC flag.

If the IRIC flag is cleared to 0 with WAIT = 1 while SCL is extending the high level period, the SDA level may change before SCL becomes low, generate a start or stop condition erroneously.

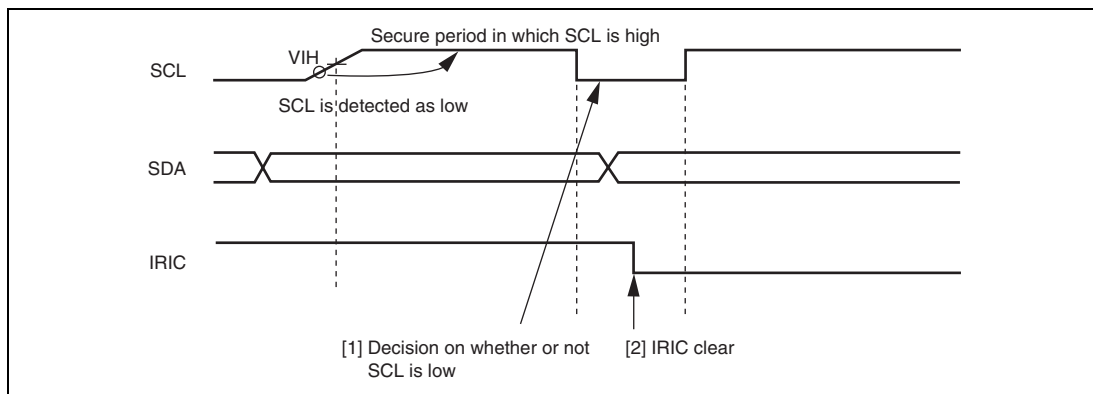

Figure 14.33 Timing for Clearing IRIC Flag When WAIT = 1

12. Points for caution when reading ICDR and accessing ICCR in slave transmit mode

In I²C bus interface slave transmit mode, do not read ICDR or do not read/write to ICCR during the period shaded in figure 14.34. However, in interrupt handling processing that is generated in synchronization with the rising edge of the 9th cycle of the clock, reading ICDR or reading/writing to ICCR causes no error because the shaded period has passed before making the transition to interrupt handling.

To handle interrupts securely, be sure to keep either of the following conditions.

- Before starting the receive operation of the next slave address, finish the read of ICDR data that has been received so far or the read/write of ICCR.
- Monitor the BC2 to BC0 counter in ICMR; when the count is 000 (8th or 9th cycle of the clock), wait for at least two transfer clocks to let the shaded period pass. Then, read ICDR or read/write to ICCR.

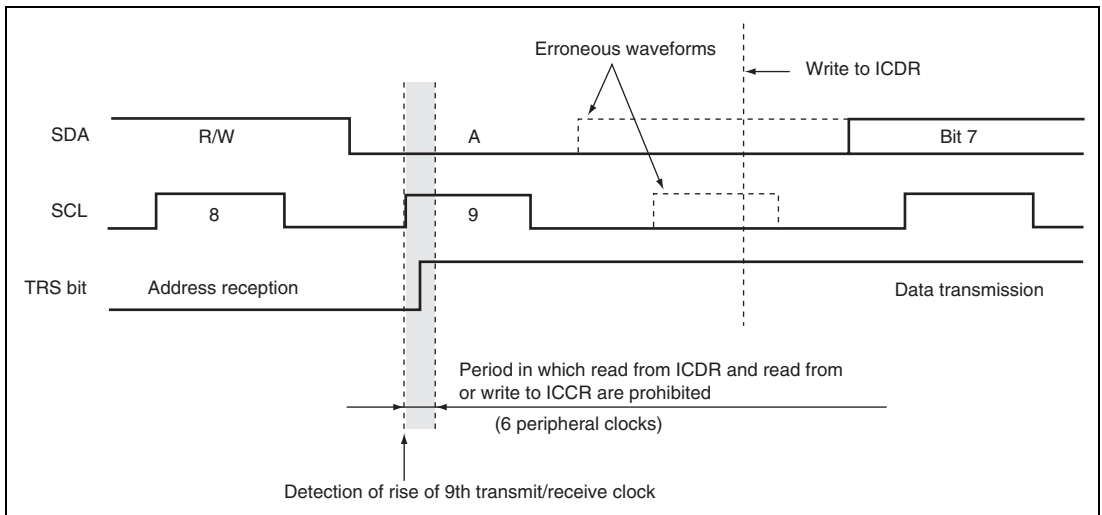

Figure 14.34 Timing for Reading ICDR and Accessing ICCR in Slave Transmit Mode

13. Points for cautions when setting TRS bit in slave mode

In I²C bus interface slave mode, the value set to the TRS bit in ICCR immediately becomes valid if it is set from the time when the rising edge of the 9th cycle or the stop condition is detected until the time when the next rising edge on the SCL pin is detected (the period indicated as (a) in figure 14.35).

However, if the TRS bit is set outside the period mentioned above (the period indicated as (b) in figure 14.35), the bit value does not become valid immediately because it is suspended until the rising edge of the 9th cycle or the stop condition is detected. Therefore, when the address is received after the re-transmission start condition input without the stop condition, the effective TRS bit value remains 1 (transmit mode) internally and thus the acknowledge bit is not transmitted after the address has been received at the 9th cycle of the clock.

To receive the address in slave mode, clear the TRS bit to 0 during the time indicated as (a) in figure 14.35.

To release SCL low-level fixation that is held by means of the wait function in slave mode, clear the TRS bit to 0 and then dummy-read ICDR.

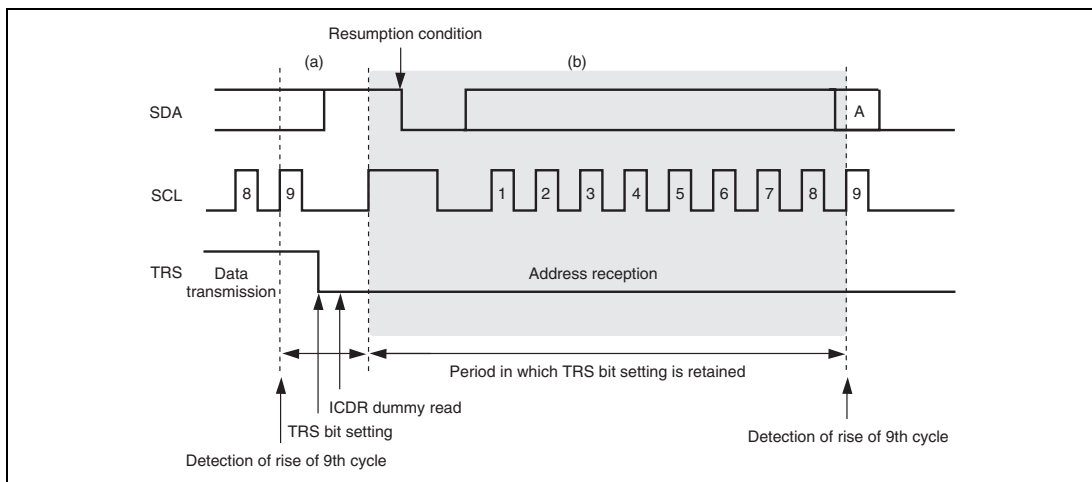

Figure 14.35 Timing for Setting TRS Bit in Slave Mode

14. Points for cautions when reading ICDR in transmit mode and writing to ICDR in receive mode

When ICDR is read in transmit mode (TRS = 1) or ICDR is written to in receive mode (TRS = 0), the SCL pin may not be held low in some cases after transmit/receive operation has been completed, thus inconveniently allowing clock pulses to be output on the SCL bus line before ICDR is accessed correctly. To access ICDR correctly, read the ICDR after setting to receive mode or write to the ICDR after setting to transmit mode.

15. Points for cautions on ACKE and TRS bits in slave mode

In the I²C bus interface, if 1 is received as the acknowledge bit value (ACKB = 1) in transmit mode (TRS = 1) and then the address is received in slave mode without performing appropriate processing, interrupt handling may start at the rising edge of the 9th cycle of the clock even when the address does not match.

Similarly, in slave mode, if the start condition or address is transmitted from the master device in transmit mode (TRS = 1), the IRIC flag may be set as a result of the ICDRE flag set or receiving 1 as the acknowledge bit value (ACKB = 1), thus causing an interrupt source to occur even when the address does not match.

To use the I²C bus interface module in slave mode, be sure to follow the procedures below.

- When 1 is received as the acknowledge bit value for the final transmit data at the end of a series of transmit operations, clear the ACKE bit in ICCR once to initialize the ACKB bit to 0.
- Set to receive mode (TRS = 0) before the next start condition is input in slave mode. Complete transmit operation by the procedure shown in figure 14.23, in order to switch from slave transmit mode to slave receive mode.

14.5.1 Module Stop Mode Setting

IIC is enabled or disabled using the module stop control register. IIC is disabled with the initial value. Cancelling module stop mode allows the register to be accessed. For details, see section 24, Power-Down Modes.

Section 15 A/D Converter

This LSI includes a successive approximation type 10-bit A/D converter. The block diagram of the A/D converter is shown in figure 15.1.

15.1 Features

- 10-bit resolution
- Input channels
 - 8 channels (two independent A/D conversion modules)
- Conversion time: 5.4 μ s per channel (at $P\phi = 25$ -MHz operation), 6.7 μ s per channel (at $P\phi = 20$ -MHz operation)
- Three operating modes
 - Single mode: Single-channel A/D conversion
 - Continuous scan mode: Continuous A/D conversion on 1 to 4 channels
 - Single-cycle scan mode: Single-cycle A/D conversion on 1 to 4 channels
- Data registers
 - Conversion results are held in a 16-bit data register for each channel
- Sample and hold function
- Three methods for conversion start
 - Software
 - Conversion start trigger from multifunction timer pulse unit (MTU)
 - External trigger signal
- Interrupt request
 - An A/D conversion end interrupt request (ADI) can be generated
- Module standby mode can be set

15. A/D Converter

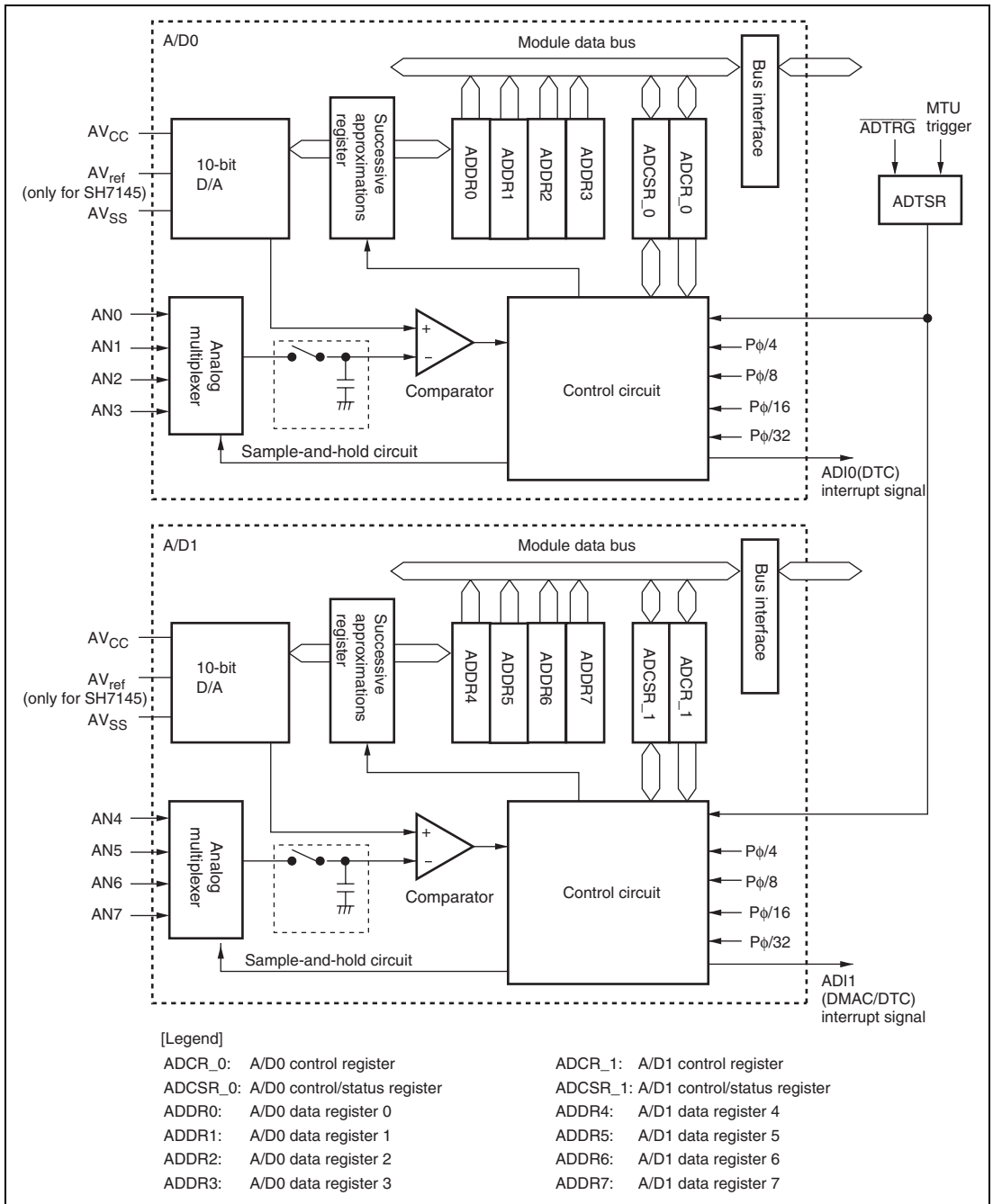

Figure 15.1 Block Diagram of A/D Converter

15.2 Input/Output Pins

Table 15.1 summarizes the input pins used by the A/D converter. This LSI has two A/D conversion modules, each of which can be operated independently. The input channels are divided into four channel sets.

The analog input pins are as shown in table 15.1.

Table 15.1 Pin Configuration

| Module Type | Pin Name | I/O | Function |
|---------------------|------------|-------|---|
| Common | AV_{cc} | Input | Analog block power supply and reference voltage |
| | AV_{ref} | Input | A/D conversion reference voltage (Only for SH7145) |
| | AV_{ss} | Input | Analog block ground and reference voltage |
| | $ADTRG$ | Input | A/D external trigger input pin |
| A/D module 0 (A/D0) | AN0 | Input | Analog input pin 0 |
| | AN1 | Input | Analog input pin 1 |
| | AN2 | Input | Analog input pin 2 |
| | AN3 | Input | Analog input pin 3 |
| A/D module 1 (A/D1) | AN4 | Input | Analog input pin 4 |
| | AN5 | Input | Analog input pin 5 |
| | AN6 | Input | Analog input pin 6 |
| | AN7 | Input | Analog input pin 7 |

Note: The connected A/D module differs for each pin. The control registers of each must be set each module. The AV_{ref} pin is internally connected to the AV_{cc} pin in the SH7144.

15.3 Register Descriptions

The A/D converter has the following registers. For details on register addresses and register states in each processing state, refer to section 25, List of Registers.

- A/D data register 0 (ADDR0)
- A/D data register 1 (ADDR1)
- A/D data register 2 (ADDR2)
- A/D data register 3 (ADDR3)
- A/D data register 4 (ADDR4)
- A/D data register 5 (ADDR5)
- A/D data register 6 (ADDR6)
- A/D data register 7 (ADDR7)
- A/D control/status register_0 (ADCSR_0)
- A/D control/status register_1 (ADCSR_1)
- A/D control register_0 (ADCR_0)
- A/D control register_1 (ADCR_1)
- A/D trigger select register (ADTSR)

15.3.1 A/D Data Registers 0 to 7 (ADDR0 to ADDR7)

ADDRs are 16-bit read-only registers. The conversion result for each analog input channel is stored in ADDR with the corresponding number. (For example, the conversion result of AN4 is stored in ADDR4.)

The converted 10-bit data is stored in bits 6 to 15. The lower 6 bits are always read as 0.

The data bus between the CPU and the A/D converter is 8 bits wide. The upper byte can be read directly from the CPU, however the lower byte should be read via a temporary register. The temporary register contents are transferred from the ADDR when the upper byte data is read. When reading the ADDR, read the upper byte before the lower byte, or read in word unit.

The initial value of ADDR is H'0000.

15.3.2 A/D Control/Status Register_0, 1 (ADCSR_0, ADCSR_1)

ADCSR for each module controls A/D conversion operations.

| Bit | Bit Name | Initial Value | R/W | Description |
|-----|----------|---------------|--------|--|
| 7 | ADF | 0 | R/(W)* | <p>A/D End Flag</p> <p>A status flag that indicates the end of A/D conversion.</p> <p>[Setting conditions]</p> <ul style="list-style-type: none"> When A/D conversion ends in single mode When A/D conversion ends on all specified channels in scan mode <p>[Clearing conditions]</p> <ul style="list-style-type: none"> When 0 is written after reading ADF = 1 When the DMAC or the DTC is activated by an ADI interrupt and data is read from ADDR while the DTMR bit in the DTC is cleared to 0 |
| 6 | ADIE | 0 | R/W | <p>A/D Interrupt Enable</p> <p>The A/D conversion end interrupt (ADI) request is enabled when 1 is set</p> <p>When changing the operating mode, first clear the ADST bit in the A/D control registers (ADCR) to 0.</p> |
| 5 | — | 0 | R | <p>Reserved</p> <p>This bit is always read as 0. The write value should always be 0.</p> |
| 4 | ADM | 0 | R/W | <p>A/D Operating Mode Select</p> <p>Selects the A/D conversion mode.</p> <p>0: Single mode 1: Scan mode</p> <p>When changing the operating mode, first clear the ADST bit in the A/D control registers (ADCR) to 0.</p> |
| 3 | — | 1 | R | <p>Reserved</p> <p>This bit is always read as 1. The write value should always be 1.</p> |
| 2 | — | 0 | R | <p>Reserved</p> <p>This bit is always read as 0. The write value should always be 0.</p> |

| Bit | Bit Name | Initial Value | R/W | Description |
|-----|----------|---------------|-----|---|
| 1 | CH1 | 0 | R/W | Channel Select 1, 0 |
| 0 | CH0 | 0 | R/W | Select analog input channels. See table 15.2. When changing the operating mode, first clear the ADST bit in the A/D control registers (ADCR) to 0. |

Note: * Only 0 can be written to clear the flag.

Table 15.2 Channel Select List

| Bit 1 | Bit 0 | Analog Input Channels | | | |
|-------|-------|-----------------------|------|------------|------------|
| | | Single Mode | | Scan Mode | |
| CH1 | CH0 | A/D0 | A/D1 | A/D0 | A/D1 |
| 0 | 0 | AN0 | AN4 | AN0 | AN4 |
| | 1 | AN1 | AN5 | AN0, AN1 | AN4, AN5 |
| 1 | 0 | AN2 | AN6 | AN0 to AN2 | AN4 to AN6 |
| | 1 | AN3 | AN7 | AN0 to AN3 | AN4 to AN7 |

15.3.3 A/D Control Register_0, 1 (ADCR_0, ADCR_1)

ADCR for each module controls A/D conversion started by an external trigger signal and selects the operating clock.

| Bit | Bit Name | Initial Value | R/W | Description |
|-----|----------|---------------|-----|---|
| 7 | TRGE | 0 | R/W | <p>Trigger Enable</p> <p>Enables or disables triggering of A/D conversion by ADTRG or an MTU trigger.</p> <p>0: A/D conversion triggering is disabled</p> <p>1: A/D conversion triggering is enabled</p> |
| 6 | CKS1 | 0 | R/W | Clock Select 1, 0 |
| 5 | CKS0 | 0 | R/W | <p>Select the A/D conversion time.</p> <p>00: $P\phi/32$</p> <p>01: $P\phi/16$</p> <p>10: $P\phi/8$</p> <p>11: $P\phi/4$</p> <p>When changing the operating mode, first clear the ADST bit in the A/D control registers (ADCR) to 0.</p> <p>CKS[1,0] = b'11 can be set while $P\phi \leq 25$ MHz.</p> |
| 4 | ADST | 0 | R/W | <p>A/D Start</p> <p>Starts or stops A/D conversion. When this bit is set to 1, A/D conversion is started. When this bit is cleared to 0, A/D conversion is stopped and the A/D converter enters the idle state. In single or single-cycle scan mode, this bit is automatically cleared to 0 when A/D conversion ends on the selected single channel. In continuous scan mode, A/D conversion is continuously performed for the selected channels in sequence until this bit is cleared by a software, reset, or in software standby mode, or module standby mode.</p> |
| 3 | ADCS | 0 | R/W | <p>A/D Continuous Scan</p> <p>Selects either single-cycle scan or continuous scan in scan mode. This bit is valid only when scan mode is selected.</p> <p>0: Single-cycle scan</p> <p>1: Continuous scan</p> <p>When changing the operating mode, first clear the ADST bit in the A/D control registers (ADCR) to 0.</p> |

| Bit | Bit Name | Initial Value | R/W | Description |
|--------|----------|---------------|-----|--|
| 2 to 0 | — | All 1 | R | Reserved These bits are always read as 1. The write value should always be 1. |

15.3.4 A/D Trigger Select Register (ADTSR)

The ADTSR enables an A/D conversion started by an external trigger signal.

| Bit | Bit Name | Initial Value | R/W | Description |
|--------|----------|---------------|-----|---|
| 7 to 4 | — | All 0 | R | Reserved These bits are always read as 0. The write value should always be 0. |
| 3 | TRG1S1 | 0 | R/W | AD Trigger 1 Select 1 and 0 |
| 2 | TRG1S0 | 0 | R/W | Enable the start of A/D conversion by A/D1 with a trigger signal. 00: A/D conversion start by external trigger pin (ADTRG) or MTU trigger is enabled 01: A/D conversion start by external trigger pin (ADTRG) is enabled 10: A/D conversion start by MTU trigger is enabled 11: Setting prohibited When changing the operating mode, first clear the ADST and TRGE bit in the A/D control registers (ADCR) to 0. |
| 1 | TRG0S1 | 0 | R/W | AD Trigger 0 Select 1 and 0 |
| 0 | TRG0S0 | 0 | R/W | Enable the start of A/D conversion by A/D0 with a trigger signal. 00: A/D conversion start by external trigger pin (ADTRG) or MTU trigger is enabled 01: A/D conversion start by external trigger pin (ADTRG) is enabled 10: A/D conversion start by MTU trigger is enabled 11: Setting prohibited When changing the operating mode, first clear the ADST and TRGE bit in the A/D control registers (ADCR) to 0. |

15.4 Operation

The A/D converter operates by successive approximation with 10-bit resolution. It has two operating modes; single mode and scan mode. There are two kinds of scan mode: continuous mode and single-cycle mode. When changing the operating mode or analog input channel, in order to prevent incorrect operation, first clear the ADST bit to 0 in ADCR. The ADST bit can be set at the same time when the operating mode or analog input channel is changed.

15.4.1 Single Mode

In single mode, A/D conversion is to be performed only once on the specified single channel. The operations are as follows.

1. A/D conversion is started when the ADST bit in ADCR is set to 1, according to software, MTU, or external trigger input.
2. When A/D conversion is completed, the result is transferred to the A/D data register corresponding to the channel.
3. On completion of conversion, the ADF bit in ADCSR is set to 1. If the ADIE bit is set to 1 at this time, an ADI interrupt request is generated.
4. The ADST bit remains set to 1 during A/D conversion. When A/D conversion ends, the ADST bit is automatically cleared to 0 and the A/D converter enters the idle state.

15.4.2 Continuous Scan Mode

In continuous scan mode, A/D conversion is to be performed sequentially on the specified channels. The operations are as follows.

1. When the ADST bit in ADCR is set to 1 by software, MTU, or external trigger input, A/D conversion starts on the channel with the lowest number in the group (AN0, AN1, ..., AN3).
2. When A/D conversion for each channel is completed, the result is sequentially transferred to the A/D data register corresponding to each channel.
3. When conversion of all the selected channels is completed, the ADF bit in ADCSR is set to 1. If the ADIE bit is set to 1 at this time, an ADI interrupt is requested after A/D conversion ends. Conversion of the first channel in the group starts again.
4. Steps 2 to 3 are repeated as long as the ADST bit remains set to 1. When the ADST bit is cleared to 0, A/D conversion stops and the A/D converter enters the idle state.

15.4.3 Single-Cycle Scan Mode

In single-cycle scan mode, A/D conversion is to be performed once on the specified channels. Operations are as follows.

1. When the ADST bit in ADCR is set to 1 by a software, MTU, or external trigger input, A/D conversion starts on the channel with the lowest number in the group (AN0, AN1, ..., AN3).
2. When A/D conversion for each channel is completed, the result is sequentially transferred to the A/D data register corresponding to each channel.
3. When conversion of all the selected channels is completed, the ADF bit in ADCSR is set to 1. If the ADIE bit is set to 1 at this time, an ADI interrupt is requested after A/D conversion ends.
4. After A/D conversion ends, the ADST bit is automatically cleared to 0 and the A/D converter enters the idle state. When the ADST bit is cleared to 0 during A/D conversion, A/D conversion stops and the A/D converter enters the idle state.

15.4.4 Input Signal Sampling and A/D Conversion Time

The A/D converter has a built-in sample-and-hold circuit for each module. The A/D converter samples the analog input when the A/D conversion start delay time (t_d) has passed after the ADST bit in ADCR is set to 1, then starts conversion. Figure 15.2 shows the A/D conversion timing. Table 15.3 shows the A/D conversion time.

As indicated in figure 15.2, the A/D conversion time (t_{CONV}) includes t_d and the input sampling time (t_{SPL}). The length of t_d varies depending on the timing of the write access to ADCR. The total conversion time therefore varies within the ranges indicated in table 15.3.

In scan mode, the values given in table 15.3 apply to the first conversion time. The values given in table 15.4 apply to the second and subsequent conversions.

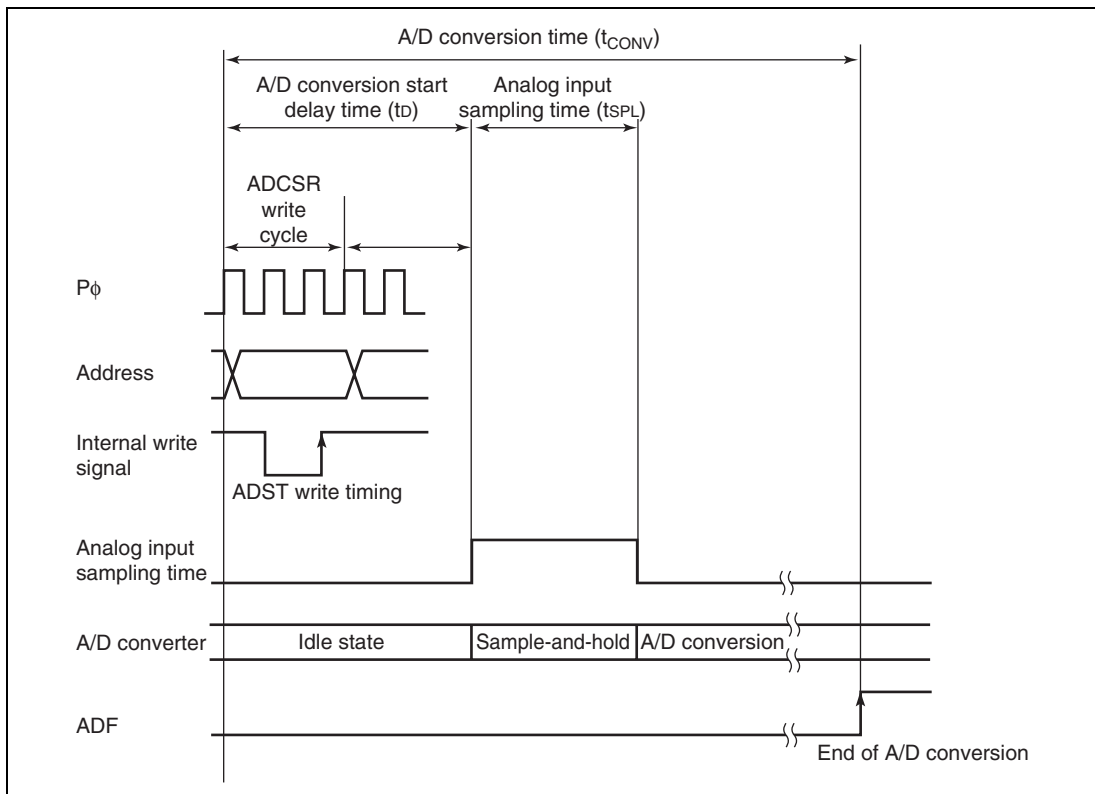

Figure 15.2 A/D Conversion Timing

Table 15.3 A/D Conversion Time (Single Mode)

| Item | Symbol | CKS1 = 0 | | | | | | CKS1 = 1 | | | | | |
|----------------------------|------------|----------|-----|------|----------|-----|-----|----------|-----|-----|----------|-----|-----|
| | | CKS0 = 0 | | | CKS0 = 1 | | | CKS0 = 0 | | | CKS0 = 1 | | |
| | | Min | Typ | Max | Min | Typ | Max | Min | Typ | Max | Min | Typ | Max |
| A/D conversion start delay | t_d | 31 | — | 62 | 15 | — | 30 | 7 | — | 14 | 3 | — | 6 |
| Input sampling time | t_{SPL} | — | 256 | — | — | 128 | — | — | 64 | — | — | 32 | — |
| A/D conversion time | t_{CONV} | 1024 | — | 1055 | 515 | — | 530 | 259 | — | 266 | 131 | — | 134 |

Note: All values represent the number of states for Pφ.

Table 15.4 A/D Conversion Time (Scan Mode)

| CKS1 | CKS0 | Conversion Time (State) |
|------|------|-------------------------|
| 0 | 0 | 1024 (Fixed) |
| | 1 | 512 (Fixed) |
| 1 | 0 | 256 (Fixed) |
| | 1 | 128 (Fixed) |

15.4.5 A/D Converter Activation by MTU

The A/D converter can be independently activated by an A/D conversion request from the interval timer of the MTU.

To activate the A/D converter by the MTU, set the A/D trigger select register (ADTSR). After this register setting has been made, the ADST bit in ADCR is automatically set to 1 when an A/D conversion request from the interval timer of the MTU occurs. The timing from setting of the ADST bit until the start of A/D conversion is the same as when 1 is written to the ADST bit by software.

15.4.6 External Trigger Input Timing

A/D conversion can be externally triggered. When the TRGS1 and TRGS0 bits are set to 00 or 01 in ADTSR, external trigger input is enabled at the $\overline{\text{ADTRG}}$ pin. A falling edge of the $\overline{\text{ADTRG}}$ pin sets the ADST bit to 1 in ADCR, starting A/D conversion. Other operations, in both single and scan modes, are the same as when the ADST bit has been set to 1 by software. Figure 15.3 shows the timing.

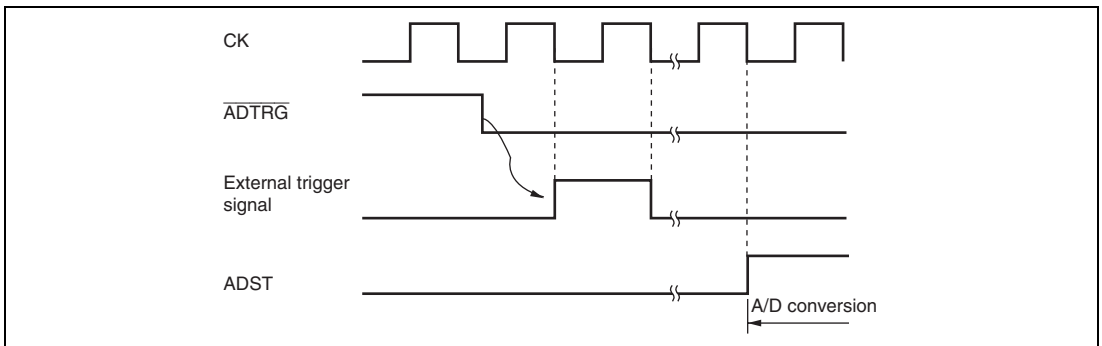

Figure 15.3 External Trigger Input Timing

15.5 Interrupt Sources and DTC, DMAC Transfer Requests

The A/D converter generates an A/D conversion end interrupt (ADI) upon the completion of A/D conversion. ADI interrupt requests are enabled when the ADIE bit is set to 1 while the ADF bit in ADCSR is set to 1 after A/D conversion is completed. The data transfer controller (DTC) or the direct memory access controller (DMAC) can be activated by an ADI interrupt. Having the converted data read by the DTC or the DMAC in response to an ADI interrupt enables continuous conversion to be achieved without imposing a load on software.

When the DTC or the DMAC is activated by an ADI interrupt, the ADF bit in ADCSR is automatically cleared when data is transferred by the DTC or the DMAC.

Table 15.5 A/D Converter Interrupt Sources

| Name | Interrupt Source | Interrupt Source Flag | DTC Activation | DMAC Activation |
|-------------|---------------------------|------------------------------|-----------------------|------------------------|
| ADI0 | A/D0 conversion completed | ADF in ADCSR_0 | Possible | Impossible |
| ADI1 | A/D1 conversion completed | ADF in ADCSR_1 | Possible | Possible |

15.6 Definitions of A/D Conversion Accuracy

This LSI's A/D conversion accuracy definitions are given below.

- Resolution
The number of A/D converter digital output codes
- Quantization error
The deviation inherent in the A/D converter, given by 1/2 LSB (see figure 15.4).
- Offset error
The deviation of the analog input voltage value from the ideal A/D conversion characteristic when the digital output changes from the minimum voltage value B'0000000000 (H'00) to B'0000000001 (H'01) (see figure 15.5).
- Full-scale error
The deviation of the analog input voltage value from the ideal A/D conversion characteristic when the digital output changes from B'1111111110 (H'3FE) to B'1111111111 (H'3FF) (see figure 15.5).
- Nonlinearity error
The error with respect to the ideal A/D conversion characteristic between zero voltage and full-scale voltage. Does not include offset error, full-scale error, or quantization error (see figure 15.5).
- Absolute accuracy
The deviation between the digital value and the analog input value. Includes offset error, full-scale error, quantization error, and nonlinearity error.

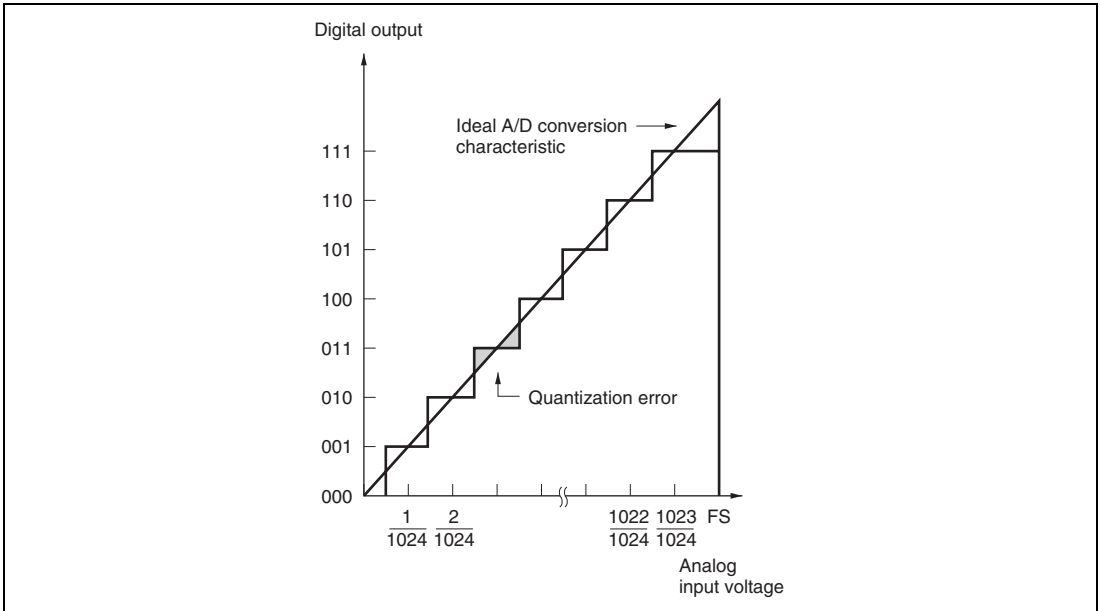

Figure 15.4 Definitions of A/D Conversion Accuracy

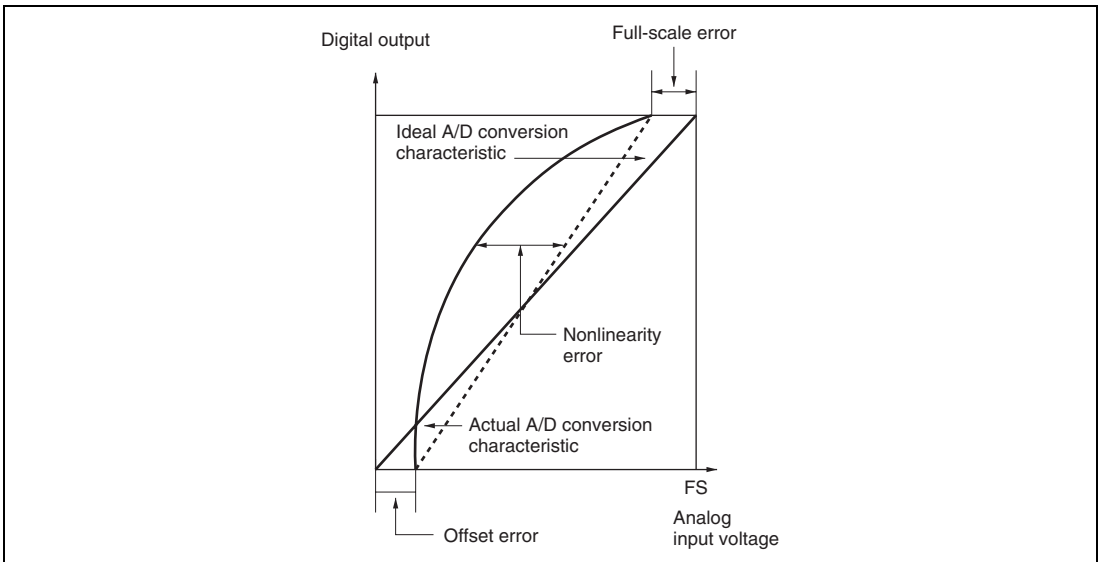

Figure 15.5 Definitions of A/D Conversion Accuracy

15.7 Usage Notes

15.7.1 Module Standby Mode Setting

Operation of the A/D converter can be disabled or enabled using the module standby control register. The initial setting is for operation of the A/D converter to be halted. Register access is enabled by clearing module standby mode. For details, refer to section 24, Power-Down Modes.

15.7.2 Permissible Signal Source Impedance

This LSI's analog input is designed such that conversion accuracy is guaranteed for an input signal for which the signal source impedance is $1\text{ k}\Omega$ or less. This specification is provided to enable the A/D converter's sample-and-hold circuit input capacitance to be charged within the sampling time; if the sensor output impedance exceeds $1\text{ k}\Omega$, charging may be insufficient and it may not be possible to guarantee A/D conversion accuracy. With a large capacitance provided externally for A/D conversion in single mode, the input impedance will essentially comprise only the internal input resistance of $10\text{ k}\Omega$, and the signal source impedance is ignored. However, as a low-pass filter effect is obtained in this case, it may not be possible to follow a high speed switching analog signal (e.g., $5\text{ mV}/\mu\text{s}$ or greater) (see figure 15.6). When converting a high-speed analog signal or performing conversion in scan mode, a low-impedance buffer should be inserted.

15.7.3 Influences on Absolute Accuracy

Adding capacitance results in coupling with GND, and therefore noise in GND may adversely affect absolute accuracy. Be sure to make the connection to an electrically stable GND such as AVss.

Care is also required to insure that filter circuits do not interfere in the accuracy by the digital signals on the printed circuit board (i.e, acting as antennas).

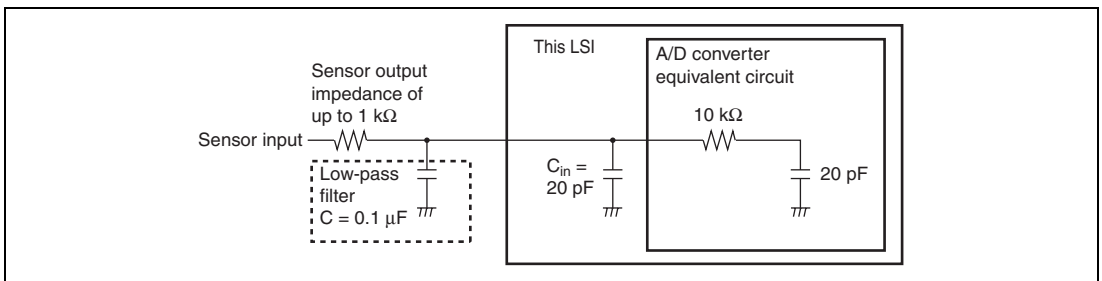

Figure 15.6 Example of Analog Input Circuit

15.7.4 Range of Analog Power Supply and Other Pin Settings

If the conditions below are not met, the reliability of the device may be adversely affected.

- Analog input voltage range
The voltage applied to analog input pin ANn (VANn) during A/D conversion should be in the range $AV_{SS} \leq VANn \leq AV_{CC}$.
- Relationship between AVcc, Avss and Vcc, Vss
The Relationship between AVcc, AVss and Vcc, Vss should be $AV_{CC} = V_{CC} \pm 0.3V$ and $AV_{SS} = V_{SS}$. If the A/D converter is not used, this relationship should be $AV_{CC} = V_{CC}$ and $AV_{SS} = V_{SS}$.
- Setting range of AVref input voltage (only for SH7145)
Set the AVref pin input voltage as $AV_{ref} \leq AV_{CC}$. If the A/D converter is not used, set the AVref pin as $AV_{ref} = AV_{CC}$.

15.7.5 Notes on Board Design

In board design, digital circuitry and analog circuitry should be as mutually isolated as possible, and layout in which digital circuit signal lines and analog circuit signal lines cross or are in close proximity should be avoided as far as possible. Failure to do so may result in incorrect operation of the analog circuitry due to inductance, adversely affecting A/D conversion values. Also, digital circuitry must be isolated from the analog input signals (AN0 to AN7), and analog power supply (AVcc) by the analog ground (AVss). Also, the analog ground (AVss) should be connected at one point to a stable digital ground (Vss) on the board.

15.7.6 Notes on Noise Countermeasures

A protection circuit should be connected in order to prevent damage due to abnormal voltage, such as an excessive surge at the analog input pins (AN0 to AN7), to AVcc and AVss, as shown in figure 15.7. Also, the bypass capacitors connected to AVcc and the filter capacitor connected to AN0 to AN7 must be connected to AVss.

If a filter capacitor is connected, the input currents at the analog input pins (AN0 to AN7) are averaged, and so an error may arise. Also, when A/D conversion is performed frequently, as in scan mode, if the current charged and discharged by the capacitance of the sample-and-hold circuit in the A/D converter exceeds the current input via the input impedance (R_m), an error will arise in the analog input pin voltage. Careful consideration is therefore required when deciding circuit constants.

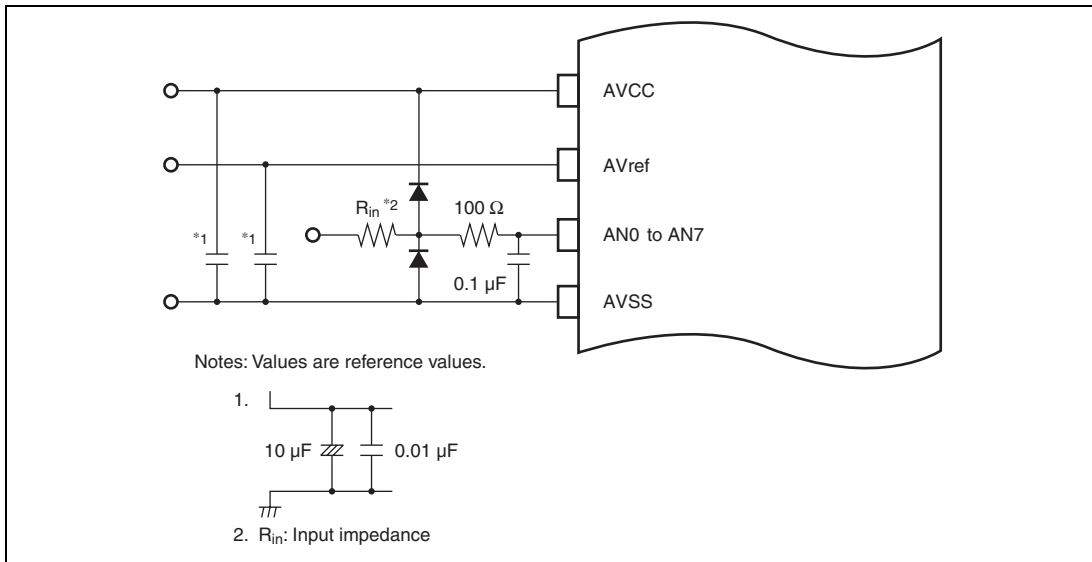

Figure 15.7 Example of Analog Input Protection Circuit

Table 15.6 Analog Pin Specifications

| Item | Min | Max | Unit |
|-------------------------------------|-----|-----|------------|
| Analog input capacitance | — | 20 | pF |
| Permissible signal source impedance | — | 1 | k Ω |

Section 16 Compare Match Timer (CMT)

This LSI has an on-chip compare match timer (CMT) comprising two 16-bit timer channels. The CMT has 16-bit counters and can generate interrupts at specified intervals.

16.1 Features

The CMT has the following features:

- Four kinds of counter input clock can be selected
 - One of four internal clocks ($P\phi/8$, $P\phi/32$, $P\phi/128$, $P\phi/512$) can be selected independently for each channel.
- Interrupt sources
 - A compare match interrupt can be requested independently for each channel.
- Module standby mode can be set

Figure 16.1 shows a block diagram of the CMT.

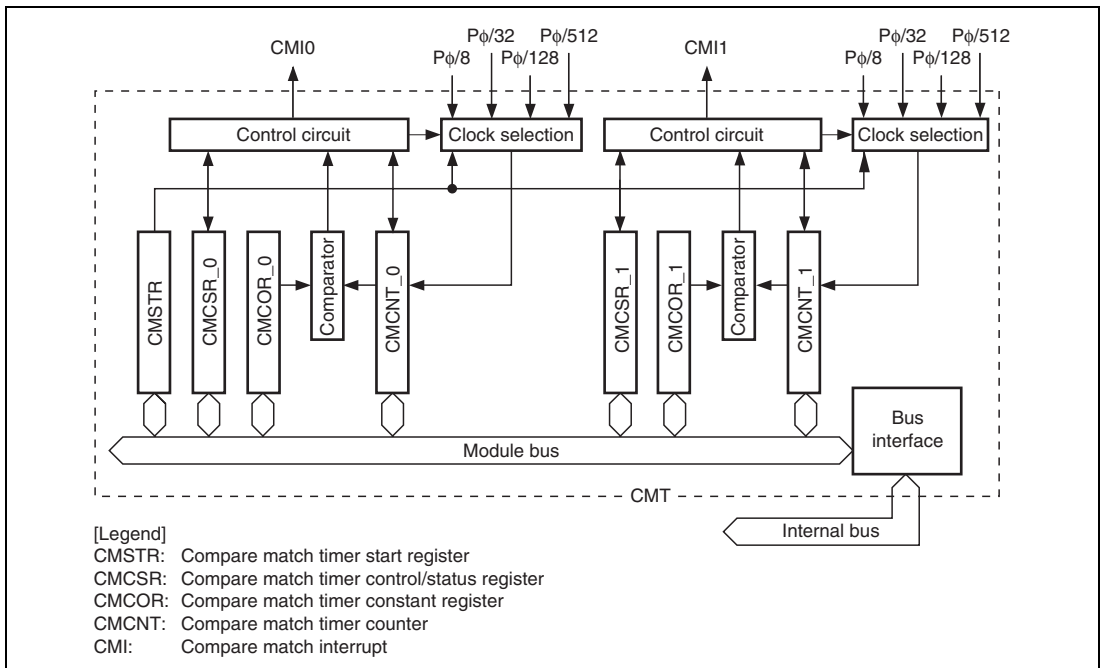

Figure 16.1 CMT Block Diagram

16.2 Register Descriptions

The CMT has the following registers. For details on register addresses and register states during each processing, refer to section 25, List of Registers.

- Compare match timer start register (CMSTR)
- Compare match timer control/status register_0 (CMCSR_0)
- Compare match timer counter_0 (CMCNT_0)
- Compare match timer constant register_0 (CMCOR_0)
- Compare match timer control/status register_1 (CMCSR_1)
- Compare match timer counter_1 (CMCNT_1)
- Compare match timer constant register_1 (CMCOR_1)

16.2.1 Compare Match Timer Start Register (CMSTR)

The compare match timer start register (CMSTR) is a 16-bit register that selects whether to operate or halt the channel 0 and channel 1 counters (CMCNT).

| Bit | Bit Name | Initial Value | R/W | Description |
|---------|----------|---------------|-----|--|
| 15 to 2 | — | All 0 | R | Reserved These bits are always read as 0. The write value should always be 0. |
| 1 | STR1 | 0 | R/W | Count Start 1 This bit selects whether to operate or halt compare match timer counter_1. (CMCNT_1) 0: CMCNT_1 count operation halted 1: CMCNT_1 count operation |
| 0 | STR0 | 0 | R/W | Count Start 0 This bit selects whether to operate or halt compare match timer counter_0. (CMCNT_0) 0: CMCNT_0 count operation halted 1: CMCNT_0 count operation |

16.2.2 Compare Match Timer Control/Status Register_0, 1 (CMCSR_0, CMCSR_1)

The compare match timer control/status register (CMCSR) is a 16-bit register that indicates the occurrence of compare matches, sets the enable/disable status of interrupts, and establishes the clock used for incrementation.

| Bit | Bit Name | Initial Value | R/W | Description |
|---------|----------|---------------|--------|---|
| 15 to 8 | — | All 0 | R | Reserved These bits are always read as 0. The write value should always be 0. |
| 7 | CMF | 0 | R/(W)* | Compare Match Flag This flag indicates whether or not the CMCNT and CMCOR values have matched. 0: CMCNT and CMCOR values have not matched 1: CMCNT and CMCOR values have matched [Clearing condition] <ul style="list-style-type: none"> • Write 0 to CMF after reading 1 from it • When the DTC is activated by an CMI interrupt and data is transferred with the DISEL bit in DTMR of DTC = 0 |
| 6 | CMIE | 0 | R/W | Compare Match Interrupt Enable This bit selects whether to enable or disable a compare match interrupt (CMI) when the CMCNT and CMCOR values have matched (CMF = 1). 0: Compare match interrupt (CMI) disabled 1: Compare match interrupt (CMI) enabled |
| 5 to 2 | — | All 0 | R | Reserved These bits are always read as 0. The write value should always be 0. |
| 1 | CKS1 | 0 | R/W | These bits select the clock input to CMCNT from among the four internal clocks obtained by dividing the peripheral clock ($P\phi$). When the STR bit of CMSTR is set to 1, CMCNT begins incrementing with the clock selected by CKS1 and CKS0. 00: $P\phi/8$ 01: $P\phi/32$ 10: $P\phi/128$ 11: $P\phi/512$ |
| 0 | CKS0 | 0 | R/W | |

Note: * Only 0 can be written for flag clearing.

16.2.3 Compare Match Timer Counter_0, 1 (CMCNT_0, CMCNT_1)

The compare match timer counter (CMCNT) is a 16-bit register used as an up-counter for generating interrupt requests.

The initial value of CMCNT is H'0000.

16.2.4 Compare Match Timer Constant Register_0, 1 (CMCOR_0, CMCOR_1)

The compare match timer constant register (CMCOR) is a 16-bit register that sets the period for compare match with CMCNT.

The initial value of CMCOR is H'FFFF.

16.3 Operation

16.3.1 Compare Match Counter Operation

When an internal clock is selected with the CKS1, CKS0 bits of the CMCSR register and the STR bit of CMSTR is set to 1, CMCNT begins incrementing with the selected clock. When the CMCNT counter value matches that of the compare match constant register (CMCOR), the CMCNT counter is cleared to H'0000 and the CMF flag of the CMCSR register is set to 1. If the CMIE bit of the CMCSR register is set to 1 at this time, a compare match interrupt (CMI) is requested. The CMCNT counter begins counting up again from H'0000.

Figure 16.2 shows the compare match counter operation.

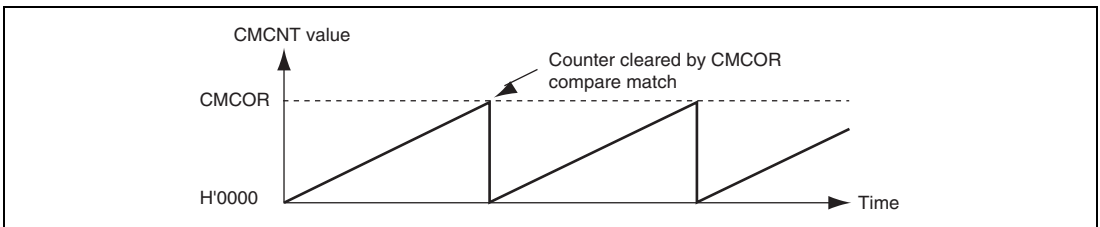

Figure 16.2 Counter Operation

16.3.2 CMCNT Count Timing

One of four clocks ($P\phi/8$, $P\phi/32$, $P\phi/128$, $P\phi/512$) obtained by dividing the peripheral clock ($P\phi$) can be selected by the CKS1 and CKS0 bits of CMCSR. Figure 16.3 shows the CMCNT count timing.

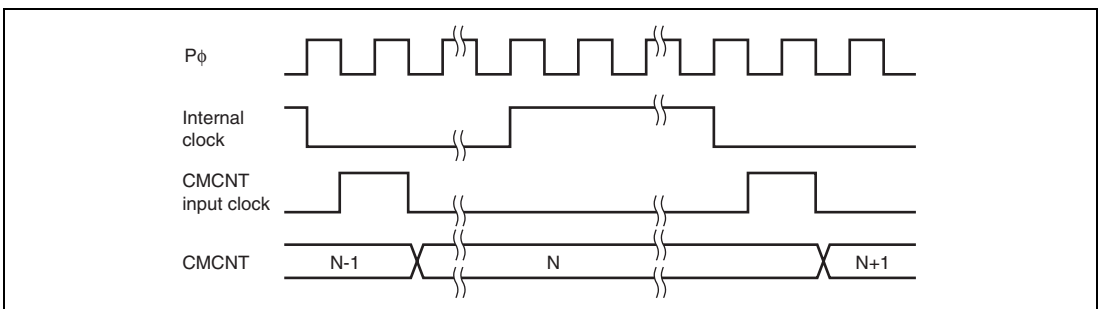

Figure 16.3 Count Timing

16.4 Interrupts

16.4.1 Interrupt Sources and DTC Activation

The CMT has a compare match interrupt for each channel, with independent vector addresses allocated to each of them. The corresponding interrupt request is output when interrupt request flag CMF is set to 1 and interrupt enable bit CMIE has also been set to 1.

When activating CPU interrupts by interrupt request, the priority between the channels can be changed by means of interrupt controller settings. See section 6, Interrupt Controller (INTC), for details.

The data transfer controller (DTC) can be activated by an interrupt request. In this case, the priority between channels is fixed. See section 8, Data Transfer Controller (DTC), for details.

16.4.2 Compare Match Flag Set Timing

The CMF bit of the CMCSR register is set to 1 by the compare match signal generated when the CMCOR register and the CMCNT counter match. The compare match signal is generated upon the final state of the match (timing at which the CMCNT counter matching count value is updated). Consequently, after the CMCOR register and the CMCNT counter match, a compare match signal will not be generated until a CMCNT counter input clock occurs. Figure 16.4 shows the CMF bit set timing.

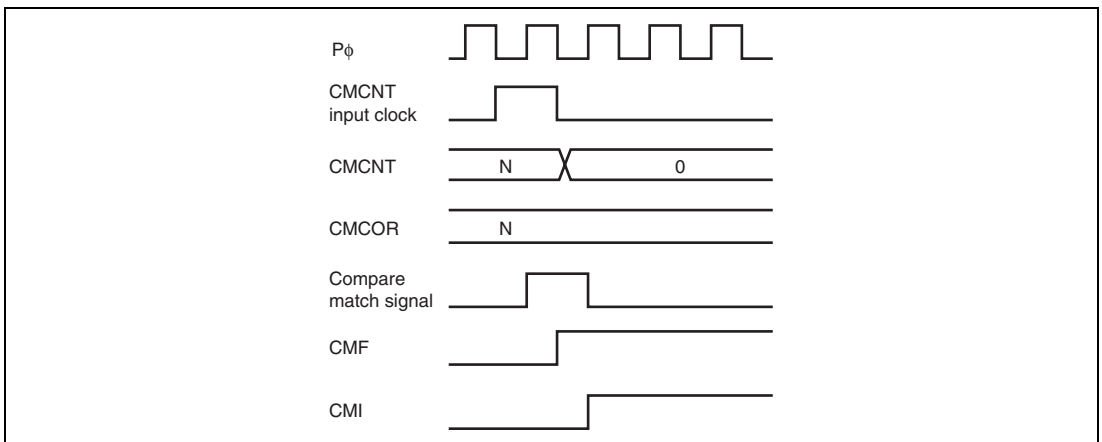

Figure 16.4 CMF Set Timing

16.4.3 Compare Match Flag Clear Timing

The CMF bit of the CMCSR register is cleared by writing a 0 to it after reading a 1 or the clearing signal after the DTC transfer. Figure 16.5 shows the timing when the CMF bit is cleared by the CPU.

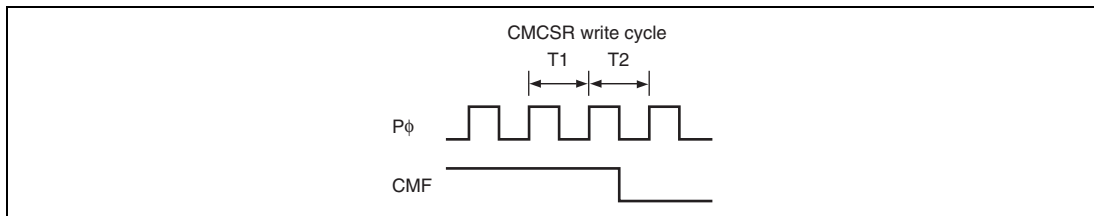

Figure 16.5 Timing of CMF Clear by CPU

16.5 Usage Notes

16.5.1 Contention between CMCNT Write and Compare Match

If a compare match signal is generated during the T2 state of the CMCNT counter write cycle, the CMCNT counter clear has priority, so the write to the CMCNT counter is not performed. Figure 16.6 shows the timing.

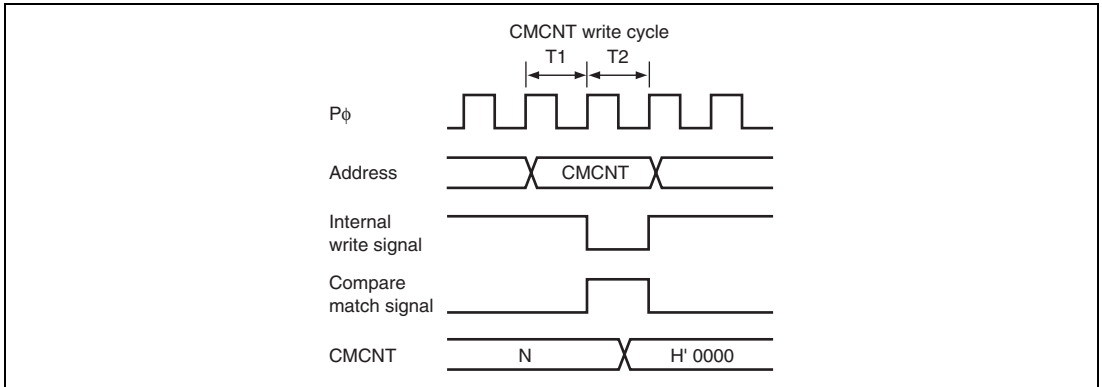

Figure 16.6 CMCNT Write and Compare Match Contention

16.5.2 Contention between CMCNT Word Write and Counter Incrementation

If an increment occurs during the T2 state of the CMCNT counter word write cycle, the counter write has priority, so no increment occurs. Figure 16.7 shows the timing.

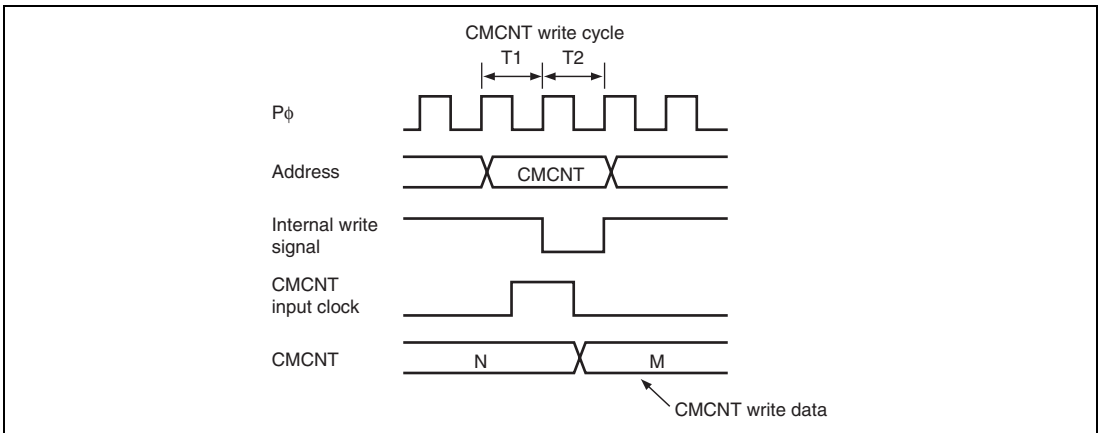

Figure 16.7 CMCNT Word Write and Increment Contention

16.5.3 Contention between CMCNT Byte Write and Counter Incrementation

If an increment occurs during the T2 state of the CMCNT byte write cycle, the counter write has priority, so no increment of the write data results on the side on which the write was performed. The byte data on the side on which writing was not performed is also not incremented, so the contents are those before the write.

Figure 16.8 shows the timing when an increment occurs during the T2 state of the CMCNT (Upper byte) write cycle.

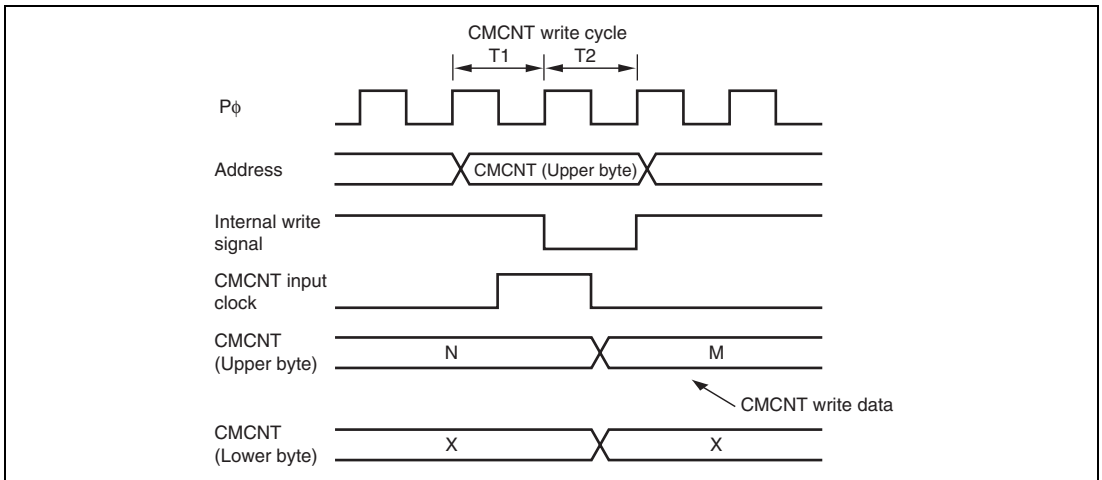

Figure 16.8 CMCNT Byte Write and Increment Contention

Section 17 Pin Function Controller (PFC)

The pin function controller (PFC) is composed of registers that are used to select the functions of multiplexed pins and assign pins to be inputs or outputs. Tables 17.1 to 17.12 list the multiplexed pins of this LSI.

Tables 17.13 and 17.14 list the pin functions in each operating mode.

Table 17.1 SH7144 Multiplexed Pins (Port A)

| Port | Function 1 (Related Module) | Function 2 (Related Module) | Function 3 (Related Module) | Function 4 (Related Module) |
|------|--------------------------------|--------------------------------------|--|---------------------------------------|
| A | PA0 I/O (port) | RXD0 input (SCI) | — | — |
| | PA1 I/O (port) | TXD0 output (SCI) | — | — |
| | PA2 I/O (port) | SCK0 I/O (SCI) | $\overline{\text{DREQ0}}$ input (DMAC) | $\overline{\text{IRQ0}}$ input (INTC) |
| | PA3 I/O (port) | RXD1 input (SCI) | — | — |
| | PA4 I/O (port) | TXD1 output (SCI) | — | — |
| | PA5 I/O (port) | SCK1 I/O (SCI) | $\overline{\text{DREQ1}}$ input (DMAC) | $\overline{\text{IRQ1}}$ input (INTC) |
| | PA6 I/O (port) | TCLKA input (MTU) | $\overline{\text{CS2}}$ output (BSC) | — |
| | PA7 I/O (port) | TCLKB input (MTU) | $\overline{\text{CS3}}$ output (BSC) | — |
| | PA8 I/O (port) | TCLKC input (MTU) | $\overline{\text{IRQ2}}$ input (INTC) | — |
| | PA9 I/O (port) | TCLKD input (MTU) | $\overline{\text{IRQ3}}$ input (INTC) | — |
| | PA10 I/O (port) | $\overline{\text{CS0}}$ output (BSC) | — | — |
| | PA11 I/O (port) | $\overline{\text{CS1}}$ output (BSC) | — | — |
| | PA12 I/O (port) | $\overline{\text{WRL}}$ output (BSC) | — | — |
| | PA13 I/O (port) | $\overline{\text{WRH}}$ output (BSC) | — | — |
| | PA14 I/O (port) | $\overline{\text{RD}}$ output (BSC) | — | — |
| | PA15 I/O (port) | CK output (CPG) | — | — |

Table 17.2 SH7144 Multiplexed Pins (Port B)

| Port | Function 1 (Related Module) | Function 2 (Related Module) | Function 3 (Related Module) | Function 4 (Related Module) | Function 5 (Related Module) |
|------|--------------------------------|---------------------------------------|---------------------------------------|---------------------------------------|--------------------------------|
| B | PB0 I/O (port) | A16 output (BSC) | — | — | — |
| | PB1 I/O (port) | A17 output (BSC) | — | — | — |
| | PB2 I/O (port) | $\overline{\text{IRQ0}}$ input (INTC) | $\overline{\text{POE0}}$ input (port) | — | SCL0 I/O (IIC) |
| | PB3 I/O (port) | $\overline{\text{IRQ1}}$ input (INTC) | $\overline{\text{POE1}}$ input (port) | — | SDA0 I/O (IIC) |
| | PB4 I/O (port) | $\overline{\text{IRQ2}}$ input (INTC) | $\overline{\text{POE2}}$ input (port) | $\overline{\text{CS6}}$ output (BSC)* | — |
| | PB5 I/O (port) | $\overline{\text{IRQ3}}$ input (INTC) | $\overline{\text{POE3}}$ input (port) | $\overline{\text{CS7}}$ output (BSC)* | — |
| | PB6 I/O (port) | $\overline{\text{IRQ4}}$ input (INTC) | A18 output (BSC) | $\overline{\text{BACK}}$ output (BSC) | — |
| | PB7 I/O (port) | $\overline{\text{IRQ5}}$ input (INTC) | A19 output (BSC) | $\overline{\text{BREQ}}$ input (BSC) | — |
| | PB8 I/O (port) | $\overline{\text{IRQ6}}$ input (INTC) | A20 output (BSC) | $\overline{\text{WAIT}}$ input (BSC) | — |
| | PB9 I/O (port) | $\overline{\text{IRQ7}}$ input (INTC) | A21 output (BSC) | $\overline{\text{ADTRG}}$ input (A/D) | — |

Note: * Masked ROM version and ROM less version only

Table 17.3 SH7144 Multiplexed Pins (Port C)

| Port | Function 1 (Related Module) | Function 2 (Related Module) | Function 3 (Related Module) | Function 4 (Related Module) |
|------|--------------------------------|--------------------------------|--------------------------------|--------------------------------|
| C | PC0 I/O (port) | A0 output (BSC) | — | — |
| | PC1 I/O (port) | A1 output (BSC) | — | — |
| | PC2 I/O (port) | A2 output (BSC) | — | — |
| | PC3 I/O (port) | A3 output (BSC) | — | — |
| | PC4 I/O (port) | A4 output (BSC) | — | — |
| | PC5 I/O (port) | A5 output (BSC) | — | — |
| | PC6 I/O (port) | A6 output (BSC) | — | — |
| | PC7 I/O (port) | A7 output (BSC) | — | — |
| | PC8 I/O (port) | A8 output (BSC) | — | — |
| | PC9 I/O (port) | A9 output (BSC) | — | — |
| | PC10 I/O (port) | A10 output (BSC) | — | — |
| | PC11 I/O (port) | A11 output (BSC) | — | — |
| | PC12 I/O (port) | A12 output (BSC) | — | — |
| | PC13 I/O (port) | A13 output (BSC) | — | — |
| | PC14 I/O (port) | A14 output (BSC) | — | — |
| | PC15 I/O (port) | A15 output (BSC) | — | — |

Table 17.4 SH7144 Multiplexed Pins (Port D)

| Port | Function 1 (Related Module) | Function 2 (Related Module) | Function 3 (Related Module) | Function 4 (Related Module) |
|-----------------|--|--|---|--|
| D | PD0 I/O (port) | D0 I/O (BSC) | — | — |
| | PD1 I/O (port) | D1 I/O (BSC) | — | — |
| | PD2 I/O (port) | D2 I/O (BSC) | — | — |
| | PD3 I/O (port) | D3 I/O (BSC) | — | — |
| | PD4 I/O (port) | D4 I/O (BSC) | — | — |
| | PD5 I/O (port) | D5 I/O (BSC) | — | — |
| | PD6 I/O (port) | D6 I/O (BSC) | — | — |
| | PD7 I/O (port) | D7 I/O (BSC) | — | — |
| | PD8 I/O (port) | D8 I/O (BSC) | AUDATA0 I/O (AUD)* | — |
| | PD9 I/O (port) | D9 I/O (BSC) | AUDATA1 I/O (AUD)* | — |
| | PD10 I/O (port) | D10 I/O (BSC) | AUDATA2 I/O (AUD)* | — |
| | PD11 I/O (port) | D11 I/O (BSC) | AUDATA3 I/O (AUD)* | — |
| | PD12 I/O (port) | D12 I/O (BSC) | $\overline{\text{AUDRST}}$ input (AUD)* | — |
| | PD13 I/O (port) | D13 I/O (BSC) | AUDMD input (AUD)* | — |
| | PD14 I/O (port) | D14 I/O (BSC) | AUDCK I/O (AUD)* | — |
| PD15 I/O (port) | D15 I/O (BSC) | $\overline{\text{AUDSYNC}}$ I/O (AUD)* | — | |

Note: * F-ZTAT version only

Table 17.5 SH7144 Multiplexed Pins (Port E)

| Port | Function 1 (Related Module) | Function 2 (Related Module) | Function 3 (Related Module) | Function 4 (Related Module) |
|------|--------------------------------|--------------------------------|--|--|
| E | PE0 I/O port | TIOC0A I/O (MTU) | $\overline{\text{DREQ0}}$ input (DMAC) | TMS input (H-UDI)* |
| | PE1 I/O port | TIOC0B I/O (MTU) | DRAK0 output (DMAC) | $\overline{\text{TRST}}$ input (H-UDI)* |
| | PE2 I/O port | TIOC0C I/O (MTU) | $\overline{\text{DREQ1}}$ input (DMAC) | TDI input (H-UDI)* |
| | PE3 I/O port | TIOC0D I/O (MTU) | DRAK1 output (DMAC) | TDO output (H-UDI)* |
| | PE4 I/O port | TIOC1A I/O (MTU) | RXD3 input (SCI) | TCK input (H-UDI)* |
| | PE5 I/O port | TIOC1B I/O (MTU) | TXD3 output (SCI) | — |
| | PE6 I/O port | TIOC2A I/O (MTU) | SCK3 I/O (SCI) | — |
| | PE7 I/O port | TIOC2B I/O (MTU) | RXD2 input (SCI) | — |
| | PE8 I/O port | TIOC3A I/O (MTU) | SCK2 I/O (SCI) | — |
| | PE9 I/O port | TIOC3B I/O (MTU) | — | SCK3 I/O (SCI) |
| | PE10 I/O port | TIOC3C I/O (MTU) | TXD2 output (SCI) | — |
| | PE11 I/O port | TIOC3D I/O (MTU) | — | RXD3 input (SCI) |
| | PE12 I/O port | TIOC4A I/O (MTU) | — | TXD3 output (SCI) |
| | PE13 I/O port | TIOC4B I/O (MTU) | $\overline{\text{MRES}}$ input (INTC) | — |
| | PE14 I/O port | TIOC4C I/O (MTU) | DACK0 output (DMAC) | — |
| | PE15 I/O port | TIOC4D I/O (MTU) | DACK1 output (DMAC) | $\overline{\text{IRQOUT}}$ output (INTC) |

Note: * F-ZTAT version only

Table 17.6 SH7144 Multiplexed Pins (Port F)

| Port | Function 1 (Related Module) | Function 2 (Related Module) | Function 3 (Related Module) | Function 4 (Related Module) |
|------|--------------------------------|--------------------------------|--------------------------------|--------------------------------|
| F | PF0 input (port) | AN0 input (A/D) | — | — |
| | PF1 input (port) | AN1 input (A/D) | — | — |
| | PF2 input (port) | AN2 input (A/D) | — | — |
| | PF3 input (port) | AN3 input (A/D) | — | — |
| | PF4 input (port) | AN4 input (A/D) | — | — |
| | PF5 input (port) | AN5 input (A/D) | — | — |
| | PF6 input (port) | AN6 input (A/D) | — | — |
| | PF7 input (port) | AN7 input (A/D) | — | — |

Table 17.7 SH7145 Multiplexed Pins (Port A)

| Port | Function 1 (Related Module) | Function 2 (Related Module) | Function 3 (Related Module) | Function 4 (Related Module) |
|------|--------------------------------|--|--|---|
| A | PA0 I/O (port) | RXD0 input (SCI) | — | — |
| | PA1 I/O (port) | TXD0 output (SCI) | — | — |
| | PA2 I/O (port) | SCK0 I/O (SCI) | $\overline{\text{DREQ0}}$ input (DMAC) | $\overline{\text{IRQ0}}$ input (INTC) |
| | PA3 I/O (port) | RXD1 input (SCI) | — | — |
| | PA4 I/O (port) | TXD1 output (SCI) | — | — |
| | PA5 I/O (port) | SCK1 I/O (SCI) | $\overline{\text{DREQ1}}$ input (DMAC) | $\overline{\text{IRQ1}}$ input (INTC) |
| | PA6 I/O (port) | TCLKA input (MTU) | $\overline{\text{CS2}}$ output (BSC) | — |
| | PA7 I/O (port) | TCLKB input (MTU) | $\overline{\text{CS3}}$ output (BSC) | — |
| | PA8 I/O (port) | TCLKC input (MTU) | $\overline{\text{IRQ2}}$ input (INTC) | — |
| | PA9 I/O (port) | TCLKD input (MTU) | $\overline{\text{IRQ3}}$ input (INTC) | — |
| | PA10 I/O (port) | $\overline{\text{CS0}}$ output (BSC) | — | — |
| | PA11 I/O (port) | $\overline{\text{CS1}}$ output (BSC) | — | — |
| | PA12 I/O (port) | $\overline{\text{WRL}}$ output (BSC) | — | — |
| | PA13 I/O (port) | $\overline{\text{WRH}}$ output (BSC) | — | — |
| | PA14 I/O (port) | $\overline{\text{RD}}$ output (BSC) | — | — |
| | PA15 I/O (port) | CK output (CPG) | — | — |
| | PA16 I/O (port) | — | — | $\overline{\text{AUDSYNC}}$ I/O (AUD)* ¹ |
| | PA17 I/O (port) | $\overline{\text{WAIT}}$ input (BSC) | — | — |
| | PA18 I/O (port) | $\overline{\text{BREQ}}$ input (BSC) | DRAK0 output (DMAC) | — |
| | PA19 I/O (port) | $\overline{\text{BACK}}$ output (BSC) | DRAK1 output (DMAC) | — |
| | PA20 I/O (port) | $\overline{\text{CS4}}$ output (BSC)* ² | — | — |
| | PA21 I/O (port) | $\overline{\text{CS5}}$ output (BSC)* ² | — | — |
| | PA22 I/O (port) | $\overline{\text{WRHL}}$ output (BSC) | — | — |
| | PA23 I/O (port) | $\overline{\text{WRHH}}$ output (BSC) | — | — |

Notes: 1. F-ZTAT version only

2. Masked ROM version and ROM less version only

Table 17.8 SH7145 Multiplexed Pins (Port B)

| Port | Function 1 (Related Module) | Function 2 (Related Module) | Function 3 (Related Module) | Function 4 (Related Module) | Function 5 (Related Module) |
|------|--------------------------------|---------------------------------------|---------------------------------------|---------------------------------------|--------------------------------|
| B | PB0 I/O (port) | A16 output (BSC) | — | — | — |
| | PB1 I/O (port) | A17 output (BSC) | — | — | — |
| | PB2 I/O (port) | $\overline{\text{IRQ0}}$ input (INTC) | $\overline{\text{POE0}}$ input (port) | — | SCL0 I/O (IIC) |
| | PB3 I/O (port) | $\overline{\text{IRQ1}}$ input (INTC) | $\overline{\text{POE1}}$ input (port) | — | SDA0 I/O (IIC) |
| | PB4 I/O (port) | $\overline{\text{IRQ2}}$ input (INTC) | $\overline{\text{POE2}}$ input (port) | $\overline{\text{CS6}}$ output (BSC)* | — |
| | PB5 I/O (port) | $\overline{\text{IRQ3}}$ input (INTC) | $\overline{\text{POE3}}$ input (port) | $\overline{\text{CS7}}$ output (BSC)* | — |
| | PB6 I/O (port) | $\overline{\text{IRQ4}}$ input (INTC) | A18 output (BSC) | $\overline{\text{BACK}}$ output (BSC) | — |
| | PB7 I/O (port) | $\overline{\text{IRQ5}}$ input (INTC) | A19 output (BSC) | $\overline{\text{BREQ}}$ input (BSC) | — |
| | PB8 I/O (port) | $\overline{\text{IRQ6}}$ input (INTC) | A20 output (BSC) | $\overline{\text{WAIT}}$ input (BSC) | — |
| | PB9 I/O (port) | $\overline{\text{IRQ7}}$ input (INTC) | A21 output (BSC) | $\overline{\text{ADTRG}}$ input (A/D) | — |

Note * Masked ROM version and ROM less version only

Table 17.9 SH7145 Multiplexed Pins (Port C)

| Port | Function 1 (Related Module) | Function 2 (Related Module) | Function 3 (Related Module) | Function 4 (Related Module) |
|------|--------------------------------|--------------------------------|--------------------------------|--------------------------------|
| C | PC0 I/O (port) | A0 output (BSC) | — | — |
| | PC1 I/O (port) | A1 output (BSC) | — | — |
| | PC2 I/O (port) | A2 output (BSC) | — | — |
| | PC3 I/O (port) | A3 output (BSC) | — | — |
| | PC4 I/O (port) | A4 output (BSC) | — | — |
| | PC5 I/O (port) | A5 output (BSC) | — | — |
| | PC6 I/O (port) | A6 output (BSC) | — | — |
| | PC7 I/O (port) | A7 output (BSC) | — | — |
| | PC8 I/O (port) | A8 output (BSC) | — | — |
| | PC9 I/O (port) | A9 output (BSC) | — | — |
| | PC10 I/O (port) | A10 output (BSC) | — | — |
| | PC11 I/O (port) | A11 output (BSC) | — | — |
| | PC12 I/O (port) | A12 output (BSC) | — | — |
| | PC13 I/O (port) | A13 output (BSC) | — | — |
| | PC14 I/O (port) | A14 output (BSC) | — | — |
| | PC15 I/O (port) | A15 output (BSC) | — | — |

Table 17.10 SH7145 Multiplexed Pins (Port D)

| Port | Function 1 (Related Module) | Function 2 (Related Module) | Function 3 (Related Module) | Function 4 (Related Module) |
|------|--------------------------------|--------------------------------|--|--------------------------------|
| D | PD0 I/O (port) | D0 I/O (BSC) | — | — |
| | PD1 I/O (port) | D1 I/O (BSC) | — | — |
| | PD2 I/O (port) | D2 I/O (BSC) | — | — |
| | PD3 I/O (port) | D3 I/O (BSC) | — | — |
| | PD4 I/O (port) | D4 I/O (BSC) | — | — |
| | PD5 I/O (port) | D5 I/O (BSC) | — | — |
| | PD6 I/O (port) | D6 I/O (BSC) | — | — |
| | PD7 I/O (port) | D7 I/O (BSC) | — | — |
| | PD8 I/O (port) | D8 I/O (BSC) | — | — |
| | PD9 I/O (port) | D9 I/O (BSC) | — | — |
| | PD10 I/O (port) | D10 I/O (BSC) | — | — |
| | PD11 I/O (port) | D11 I/O (BSC) | — | — |
| | PD12 I/O (port) | D12 I/O (BSC) | — | — |
| | PD13 I/O (port) | D13 I/O (BSC) | — | — |
| | PD14 I/O (port) | D14 I/O (BSC) | — | — |
| | PD15 I/O (port) | D15 I/O (BSC) | — | — |
| | PD16 I/O (port) | D16 I/O (BSC) | $\overline{\text{IRQ0}}$ input (INTC) | AUDATA0 I/O (AUD)* |
| | PD17 I/O (port) | D17 I/O (BSC) | $\overline{\text{IRQ1}}$ input (INTC) | AUDATA1 I/O (AUD)* |
| | PD18 I/O (port) | D18 I/O (BSC) | $\overline{\text{IRQ2}}$ input (INTC) | AUDATA2 I/O (AUD)* |
| | PD19 I/O (port) | D19 I/O (BSC) | $\overline{\text{IRQ3}}$ input (INTC) | AUDATA3 I/O (AUD)* |
| | PD20 I/O (port) | D20 I/O (BSC) | $\overline{\text{IRQ4}}$ input (INTC) | AUDRST input (AUD)* |
| | PD21 I/O (port) | D21 I/O (BSC) | $\overline{\text{IRQ5}}$ input (INTC) | AUDMD input (AUD)* |
| | PD22 I/O (port) | D22 I/O (BSC) | $\overline{\text{IRQ6}}$ input (INTC) | AUDCK I/O (AUD)* |
| | PD23 I/O (port) | D23 I/O (BSC) | $\overline{\text{IRQ7}}$ input (INTC) | AUDSYNC I/O (AUD)* |
| | PD24 I/O (port) | D24 I/O (BSC) | $\overline{\text{DREQ0}}$ input (DMAC) | — |
| | PD25 I/O (port) | D25 I/O (BSC) | $\overline{\text{DREQ1}}$ input (DMAC) | — |
| | PD26 I/O (port) | D26 I/O (BSC) | DACK0 output (DMAC) | — |
| | PD27 I/O (port) | D27 I/O (BSC) | DACK1 output (DMAC) | — |
| | PD28 I/O (port) | D28 I/O (BSC) | $\overline{\text{CS2}}$ output (BSC) | — |
| | PD29 I/O (port) | D29 I/O (BSC) | $\overline{\text{CS3}}$ output (BSC) | — |
| | PD30 I/O (port) | D30 I/O (BSC) | $\overline{\text{IRQOUT}}$ output (INTC) | — |
| | PD31 I/O (port) | D31 I/O (BSC) | $\overline{\text{ADTRG}}$ input (A/D) | — |

Note: * F-ZTAT version only

Table 17.11 SH7145 Multiplexed Pins (Port E)

| Port | Function 1 (Related Module) | Function 2 (Related Module) | Function 3 (Related Module) | Function 4 (Related Module) |
|-----------------|--------------------------------|--------------------------------|--|---|
| E | PE0 I/O (port) | TIOC0A I/O (MTU) | $\overline{\text{DREQ0}}$ input (DMAC) | AUDCK I/O (AUD)* |
| | PE1 I/O (port) | TIOC0B I/O (MTU) | DACK0 output (DMAC) | AUDMD input (AUD)* |
| | PE2 I/O (port) | TIOC0C I/O (MTU) | $\overline{\text{DREQ1}}$ input (DMAC) | $\overline{\text{AUDRST}}$ input (AUD)* |
| | PE3 I/O (port) | TIOC0D I/O (MTU) | DACK1 output (DMAC) | AUDATA3 I/O (AUD)* |
| | PE4 I/O (port) | TIOC1A I/O (MTU) | RXD3 input (SCI) | AUDATA2 I/O (AUD)* |
| | PE5 I/O (port) | TIOC1B I/O (MTU) | TXD3 output (SCI) | AUDATA1 I/O (AUD)* |
| | PE6 I/O (port) | TIOC2A I/O (MTU) | SCK3 I/O (SCI) | AUDATA0 I/O (AUD)* |
| | PE7 I/O (port) | TIOC2B I/O (MTU) | RXD2 input (SCI) | — |
| | PE8 I/O (port) | TIOC3A I/O (MTU) | SCK2 I/O (SCI) | TMS input (H-UDI)* |
| | PE9 I/O (port) | TIOC3B I/O (MTU) | $\overline{\text{TRST}}$ input (H-UDI)* | SCK3 I/O (SCI) |
| | PE10 I/O (port) | TIOC3C I/O (MTU) | TXD2 output (SCI) | TDI input (H-UDI)* |
| | PE11 I/O (port) | TIOC3D I/O (MTU) | TDO output (H-UDI)* | RXD3 input (SCI) |
| | PE12 I/O (port) | TIOC4A I/O (MTU) | TCK input (H-UDI)* | TXD3 output (SCI) |
| | PE13 I/O (port) | TIOC4B I/O (MTU) | $\overline{\text{MRES}}$ input (INTC) | — |
| | PE14 I/O (port) | TIOC4C I/O (MTU) | DACK0 output (DMAC) | — |
| PE15 I/O (port) | TIOC4D I/O (MTU) | DACK1 output (DMAC) | $\overline{\text{IRQOUT}}$ output (INTC) | |

Note: * F-ZTAT version only

Table 17.12 SH7145 Multiplexed Pins (Port F)

| Port | Function 1 (Related Module) | Function 2 (Related Module) | Function 3 (Related Module) | Function 4 (Related Module) |
|------|--------------------------------|--------------------------------|--------------------------------|--------------------------------|
| F | PF0 input (port) | AN0 input (A/D) | — | — |
| | PF1 input (port) | AN1 input (A/D) | — | — |
| | PF2 input (port) | AN2 input (A/D) | — | — |
| | PF3 input (port) | AN3 input (A/D) | — | — |
| | PF4 input (port) | AN4 input (A/D) | — | — |
| | PF5 input (port) | AN5 input (A/D) | — | — |
| | PF6 input (port) | AN6 input (A/D) | — | — |
| | PF7 input (port) | AN7 input (A/D) | — | — |

Table 17.13 SH7144 Pin Functions in Each Mode (1)

| Pin No. | Pin Name | | | |
|-------------------------------------|-----------------------------------|-------------------------------------|-----------------------------------|-------------------------------------|
| | On-Chip ROM Disabled (MCU Mode 0) | | On-Chip ROM Disabled (MCU Mode 1) | |
| | Initial Function | PFC Selected Function Possibilities | Initial Function | PFC Selected Function Possibilities |
| SH7144 | | | | |
| 21, 37, 65, 103 | Vcc | Vcc | Vcc | Vcc |
| 3, 23, 39, 55, 61, 71, 90, 101, 109 | Vss | Vss | Vss | Vss |
| 100 | AVcc | AVcc | AVcc | AVcc |
| 97 | AVss | AVss | AVss | AVss |
| 80 | PLLvcc | PLLvcc | PLLvcc | PLLvcc |
| 81 | PLLCAP | PLLCAP | PLLCAP | PLLCAP |
| 82 | PLLvss | PLLvss | PLLvss | PLLvss |
| 1 | PE14 | PE14/TIOC4C/DACK0 | PE14 | PE14/TIOC4C/DACK0 |
| 2 | PE15 | PE15/TIOC4D/DACK1/IRQOUT | PE15 | PE15/TIOC4D/DACK1/IRQOUT |
| 4 | A0 | PC0/A0 | A0 | PC0/A0 |
| 5 | A1 | PC1/A1 | A1 | PC1/A1 |
| 6 | A2 | PC2/A2 | A2 | PC2/A2 |
| 7 | A3 | PC3/A3 | A3 | PC3/A3 |
| 8 | A4 | PC4/A4 | A4 | PC4/A4 |
| 9 | A5 | PC5/A5 | A5 | PC5/A5 |
| 10 | A6 | PC6/A6 | A6 | PC6/A6 |
| 11 | A7 | PC7/A7 | A7 | PC7/A7 |
| 12 | A8 | PC8/A8 | A8 | PC8/A8 |
| 13 | A9 | PC9/A9 | A9 | PC9/A9 |
| 14 | A10 | PC10/A10 | A10 | PC10/A10 |
| 15 | A11 | PC11/A11 | A11 | PC11/A11 |
| 16 | A12 | PC12/A12 | A12 | PC12/A12 |
| 17 | A13 | PC13/A13 | A13 | PC13/A13 |
| 18 | A14 | PC14/A14 | A14 | PC14/A14 |
| 19 | A15 | PC15/A15 | A15 | PC15/A15 |
| 20 | A16 | PB0/A16 | A16 | PB0/A16 |
| 22 | A17 | PB1/A17 | A17 | PB1/A17 |

17. Pin Function Controller (PFC)

Pin Name

| Pin No. | On-Chip ROM Disabled (MCU Mode 0) | | On-Chip ROM Disabled (MCU Mode 1) | |
|---------|-----------------------------------|---|-----------------------------------|---|
| | Initial Function | PFC Selected Function Possibilities | Initial Function | PFC Selected Function Possibilities |
| SH7144 | | | | |
| 24 | PB2 | PB2/ $\overline{\text{IRQ0}}$ / $\overline{\text{POE0}}$ / $\overline{\text{SCL0}}$ | PB2 | PB2/ $\overline{\text{IRQ0}}$ / $\overline{\text{POE0}}$ / $\overline{\text{SCL0}}$ |
| 25 | PB3 | PB3/ $\overline{\text{IRQ1}}$ / $\overline{\text{POE1}}$ / $\overline{\text{SDA0}}$ | PB3 | PB3/ $\overline{\text{IRQ1}}$ / $\overline{\text{POE1}}$ / $\overline{\text{SDA0}}$ |
| 26 | PB4 | PB4/ $\overline{\text{IRQ2}}$ / $\overline{\text{POE2}}$ / $\overline{\text{CS6}}^{*3}$ | PB4 | PB4/ $\overline{\text{IRQ2}}$ / $\overline{\text{POE2}}$ / $\overline{\text{CS6}}^{*3}$ |
| 27 | $\overline{\text{ASEBRKAK}}^{*1}$ | $\overline{\text{ASEBRKAK}}^{*1}$ | $\overline{\text{ASEBRKAK}}^{*1}$ | $\overline{\text{ASEBRKAK}}^{*1}$ |
| 28 | PB5 | PB5/ $\overline{\text{IRQ3}}$ / $\overline{\text{POE3}}$ / $\overline{\text{CS7}}^{*3}$ | PB5 | PB5/ $\overline{\text{IRQ3}}$ / $\overline{\text{POE3}}$ / $\overline{\text{CS7}}^{*3}$ |
| 29 | PB6 | PB6/ $\overline{\text{IRQ4}}$ /A18/ $\overline{\text{BACK}}$ | PB6 | PB6/ $\overline{\text{IRQ4}}$ /A18/ $\overline{\text{BACK}}$ |
| 30 | PB7 | PB7/ $\overline{\text{IRQ5}}$ /A19/ $\overline{\text{BREQ}}$ | PB7 | PB7/ $\overline{\text{IRQ5}}$ /A19/ $\overline{\text{BREQ}}$ |
| 31 | PB8 | PB8/ $\overline{\text{IRQ6}}$ /A20/ $\overline{\text{WAIT}}$ | PB8 | PB8/ $\overline{\text{IRQ6}}$ /A20/ $\overline{\text{WAIT}}$ |
| 32 | PB9 | PB9/ $\overline{\text{IRQ7}}$ /A21/ $\overline{\text{ADTRG}}$ | PB9 | PB9/ $\overline{\text{IRQ7}}$ /A21/ $\overline{\text{ADTRG}}$ |
| 33 | $\overline{\text{DBGMD}}^{*1}$ | $\overline{\text{DBGMD}}^{*1}$ | $\overline{\text{DBGMD}}^{*1}$ | $\overline{\text{DBGMD}}^{*1}$ |
| 34 | $\overline{\text{RD}}$ | PA14/ $\overline{\text{RD}}$ | $\overline{\text{RD}}$ | PA14/ $\overline{\text{RD}}$ |
| 35 | $\overline{\text{WDTOVF}}$ | $\overline{\text{WDTOVF}}$ | $\overline{\text{WDTOVF}}$ | $\overline{\text{WDTOVF}}$ |
| 36 | $\overline{\text{WRH}}$ | PA13/ $\overline{\text{WRH}}$ | $\overline{\text{WRH}}$ | PA13/ $\overline{\text{WRH}}$ |
| 38 | $\overline{\text{WRL}}$ | PA12/ $\overline{\text{WRL}}$ | $\overline{\text{WRL}}$ | PA12/ $\overline{\text{WRL}}$ |
| 40 | $\overline{\text{CS1}}$ | PA11/ $\overline{\text{CS1}}$ | $\overline{\text{CS1}}$ | PA11/ $\overline{\text{CS1}}$ |
| 41 | $\overline{\text{CS0}}$ | PA10/ $\overline{\text{CS0}}$ | $\overline{\text{CS0}}$ | PA10/ $\overline{\text{CS0}}$ |
| 42 | PA9 | PA9/ $\overline{\text{TCLKD}}$ / $\overline{\text{IRQ3}}$ | PA9 | PA9/ $\overline{\text{TCLKD}}$ / $\overline{\text{IRQ3}}$ |
| 43 | PA8 | PA8/ $\overline{\text{TCLKC}}$ / $\overline{\text{IRQ2}}$ | PA8 | PA8/ $\overline{\text{TCLKC}}$ / $\overline{\text{IRQ2}}$ |
| 44 | PA7 | PA7/ $\overline{\text{TCLKB}}$ / $\overline{\text{CS3}}$ | PA7 | PA7/ $\overline{\text{TCLKB}}$ / $\overline{\text{CS3}}$ |
| 45 | PA6 | PA6/ $\overline{\text{TCLKA}}$ / $\overline{\text{CS2}}$ | PA6 | PA6/ $\overline{\text{TCLKA}}$ / $\overline{\text{CS2}}$ |
| 46 | PA5 | PA5/ $\overline{\text{SCK1}}$ / $\overline{\text{DREQ1}}$ / $\overline{\text{IRQ1}}$ | PA5 | PA5/ $\overline{\text{SCK1}}$ / $\overline{\text{DREQ1}}$ / $\overline{\text{IRQ1}}$ |
| 47 | PA4 | PA4/ $\overline{\text{TXD1}}$ | PA4 | PA4/ $\overline{\text{TXD1}}$ |
| 48 | PA3 | PA3/ $\overline{\text{RXD1}}$ | PA3 | PA3/ $\overline{\text{RXD1}}$ |
| 49 | PA2 | PA2/ $\overline{\text{SCK0}}$ / $\overline{\text{DREQ0}}$ / $\overline{\text{IRQ0}}$ | PA2 | PA2/ $\overline{\text{SCK0}}$ / $\overline{\text{DREQ0}}$ / $\overline{\text{IRQ0}}$ |
| 50 | PA1 | PA1/ $\overline{\text{TXD0}}$ | PA1 | PA1/ $\overline{\text{TXD0}}$ |
| 51 | PA0 | PA0/ $\overline{\text{RXD0}}$ | PA0 | PA0/ $\overline{\text{RXD0}}$ |
| 52 | PD15 | PD15/D15/ $\overline{\text{AUDSYNC}}^{*1}$ | D15 | PD15/D15/ $\overline{\text{AUDSYNC}}^{*1}$ |
| 53 | PD14 | PD14/D14/ $\overline{\text{AUDCK}}^{*1}$ | D14 | PD14/D14/ $\overline{\text{AUDCK}}^{*1}$ |
| 54 | PD13 | PD13/D13/ $\overline{\text{AUDMD}}^{*1}$ | D13 | PD13/D13/ $\overline{\text{AUDMD}}^{*1}$ |
| 56 | PD12 | PD12/D12/ $\overline{\text{AUDRST}}^{*1}$ | D12 | PD12/D12/ $\overline{\text{AUDRST}}^{*1}$ |
| 57 | PD11 | PD11/D11/ $\overline{\text{AUDATA3}}^{*1}$ | D11 | PD11/D11/ $\overline{\text{AUDATA3}}^{*1}$ |
| 58 | PD10 | PD10/D10/ $\overline{\text{AUDATA2}}^{*1}$ | D10 | PD10/D10/ $\overline{\text{AUDATA2}}^{*1}$ |

| Pin No. | Pin Name | | | |
|---------|--|-------------------------------------|--|-------------------------------------|
| | On-Chip ROM Disabled (MCU Mode 0) | | On-Chip ROM Disabled (MCU Mode 1) | |
| | Initial Function | PFC Selected Function Possibilities | Initial Function | PFC Selected Function Possibilities |
| SH7144 | | | | |
| 59 | PD9 | PD9/D9/AUDATA1* ¹ | D9 | PD9/D9/AUDATA1* ¹ |
| 60 | PD8 | PD8/D8/AUDATA0* ¹ | D8 | PD8/D8/AUDATA0* ¹ |
| 62 | D7 | PD7/D7 | D7 | PD7/D7 |
| 63 | D6 | PD6/D6 | D6 | PD6/D6 |
| 64 | D5 | PD5/D5 | D5 | PD5/D5 |
| 66 | D4 | PD4/D4 | D4 | PD4/D4 |
| 67 | D3 | PD3/D3 | D3 | PD3/D3 |
| 68 | D2 | PD2/D2 | D2 | PD2/D2 |
| 69 | D1 | PD1/D1 | D1 | PD1/D1 |
| 70 | D0 | PD0/D0 | D0 | PD0/D0 |
| 72 | XTAL | XTAL | XTAL | XTAL |
| 73 | MD3 | MD3 | MD3 | MD3 |
| 74 | EXTAL | EXTAL | EXTAL | EXTAL |
| 75 | MD2 | MD2 | MD2 | MD2 |
| 76 | NMI | NMI | NMI | NMI |
| 77 | FWP* ¹ | FWP* ¹ | FWP* ¹ | FWP* ¹ |
| 78 | MD1 | MD1 | MD1 | MD1 |
| 79 | MD0 | MD0 | MD0 | MD0 |
| 83 | CK | PA15/CK | CK | PA15/CK |
| 84 | $\overline{\text{RES}}$ | $\overline{\text{RES}}$ | $\overline{\text{RES}}$ | $\overline{\text{RES}}$ |
| 85 | PE0/(TMS* ¹ * ²) | PE0/TIOC0A/DREQ0 | PE0/(TMS* ¹ * ²) | PE0/TIOC0A/DREQ0 |
| 86 | PE1/(TRST* ¹ * ²) | PE1/TIOC0B/DRAK0 | PE1/(TRST* ¹ * ²) | PE1/TIOC0B/DRAK0 |
| 87 | PE2/(TDI* ¹ * ²) | PE2/TIOC0C/DREQ1 | PE2/(TDI* ¹ * ²) | PE2/TIOC0C/DREQ1 |
| 88 | PE3/(TDO* ¹ * ²) | PE3/TIOC0D/DRAK1 | PE3/(TDO* ¹ * ²) | PE3/TIOC0D/DRAK1 |
| 89 | PE4/(TCK* ¹ * ²) | PE4/TIOC1A/RXD3 | PE4/(TCK* ¹ * ²) | PE4/TIOC1A/RXD3 |
| 91 | PF0/AN0 | PF0/AN0 | PF0/AN0 | PF0/AN0 |
| 92 | PF1/AN1 | PF1/AN1 | PF1/AN1 | PF1/AN1 |
| 93 | PF2/AN2 | PF2/AN2 | PF2/AN2 | PF2/AN2 |
| 94 | PF3/AN3 | PF3/AN3 | PF3/AN3 | PF3/AN3 |
| 95 | PF4/AN4 | PF4/AN4 | PF4/AN4 | PF4/AN4 |
| 96 | PF5/AN5 | PF5/AN5 | PF5/AN5 | PF5/AN5 |
| 98 | PF6/AN6 | PF6/AN6 | PF6/AN6 | PF6/AN6 |

| Pin No. | Pin Name | | | |
|---------|-----------------------------------|-------------------------------------|-----------------------------------|-------------------------------------|
| | On-Chip ROM Disabled (MCU Mode 0) | | On-Chip ROM Disabled (MCU Mode 1) | |
| | Initial Function | PFC Selected Function Possibilities | Initial Function | PFC Selected Function Possibilities |
| SH7144 | | | | |
| 99 | PF7/AN7 | PF7/AN7 | PF7/AN7 | PF7/AN7 |
| 102 | PE5 | PE5/TIOC1B/TXD3 | PE5 | PE5/TIOC1B/TXD3 |
| 104 | PE6 | PE6/TIOC2A/SCK3 | PE6 | PE6/TIOC2A/SCK3 |
| 105 | PE7 | PE7/TIOC2B/RXD2 | PE7 | PE7/TIOC2B/RXD2 |
| 106 | PE8 | PE8/TIOC3A/ SCK2 | PE8 | PE8/TIOC3A/SCK2 |
| 107 | PE9 | PE9/TIOC3B/ SCK3 | PE9 | PE9/TIOC3B/SCK3 |
| 108 | PE10 | PE10/TIOC3C/TXD2 | PE10 | PE10/TIOC3C/TXD2 |
| 110 | PE11 | PE11/TIOC3D/RXD3 | PE11 | PE11/TIOC3D/RXD3 |
| 111 | PE12 | PE12/TIOC4A/TXD3 | PE12 | PE12/TIOC4A/TXD3 |
| 112 | PE13 | PE13/TIOC4B/MRES | PE13 | PE13/TIOC4B/MRES |

Notes: 1. F-ZTAT version only

2. Fixed to TMS, TRST, TDI, TDO, and TCK when using the E10A (in DBGMD = high).

3. Masked ROM version and ROM less version only

Table 17.13 SH7144 Pin Functions in Each Mode (2)

| Pin No. | Pin Name | | | |
|-------------------------------------|----------------------------------|-------------------------------------|-------------------------------|-------------------------------------|
| | On-Chip ROM Enabled (MCU Mode 2) | | Single Chip Mode (MCU Mode 3) | |
| | Initial Function | PFC Selected Function Possibilities | Initial Function | PFC Selected Function Possibilities |
| SH7144 | | | | |
| 21, 37, 65, 103 | Vcc | Vcc | Vcc | Vcc |
| 3, 23, 39, 55, 61, 71, 90, 101, 109 | Vss | Vss | Vss | Vss |
| 100 | AVcc | AVcc | AVcc | AVcc |
| 97 | AVss | AVss | AVss | AVss |
| 80 | PLLVcc | PLLVcc | PLLVcc | PLLVcc |
| 81 | PLLCAP | PLLCAP | PLLCAP | PLLCAP |
| 82 | PLLVss | PLLVss | PLLVss | PLLVss |
| 1 | PE14 | PE14/TIOC4C/DACK0 | PE14 | PE14/TIOC4C/DACK0 |
| 2 | PE15 | PE15/TIOC4D/DACK1/IRQOUT | PE15 | PE15/TIOC4D/DACK1/IRQOUT |
| 4 | PC0 | PC0/A0 | PC0 | PC0/A0 |
| 5 | PC1 | PC1/A1 | PC1 | PC1/A1 |
| 6 | PC2 | PC2/A2 | PC2 | PC2/A2 |
| 7 | PC3 | PC3/A3 | PC3 | PC3/A3 |
| 8 | PC4 | PC4/A4 | PC4 | PC4/A4 |
| 9 | PC5 | PC5/A5 | PC5 | PC5/A5 |
| 10 | PC6 | PC6/A6 | PC6 | PC6/A6 |
| 11 | PC7 | PC7/A7 | PC7 | PC7/A7 |
| 12 | PC8 | PC8/A8 | PC8 | PC8/A8 |
| 13 | PC9 | PC9/A9 | PC9 | PC9/A9 |
| 14 | PC10 | PC10/A10 | PC10 | PC10/A10 |
| 15 | PC11 | PC11/A11 | PC11 | PC11/A11 |
| 16 | PC12 | PC12/A12 | PC12 | PC12/A12 |
| 17 | PC13 | PC13/A13 | PC13 | PC13/A13 |
| 18 | PC14 | PC14/A14 | PC14 | PC14/A14 |
| 19 | PC15 | PC15/A15 | PC15 | PC15/A15 |
| 20 | PB0 | PB0/A16 | PB0 | PB0/A16 |
| 22 | PB1 | PB1/A17 | PB1 | PB1/A17 |

17. Pin Function Controller (PFC)

Pin Name

| Pin No. | On-Chip ROM Enabled (MCU Mode 2) | | Single Chip Mode (MCU Mode 3) | |
|---------|-----------------------------------|---|-----------------------------------|---|
| | Initial Function | PFC Selected Function Possibilities | Initial Function | PFC Selected Function Possibilities |
| SH7144 | | | | |
| 24 | PB2 | PB2/ $\overline{\text{IRQ0}}$ / $\overline{\text{POE0}}$ / $\overline{\text{SCL0}}$ | PB2 | PB2/ $\overline{\text{IRQ0}}$ / $\overline{\text{POE0}}$ / $\overline{\text{SCL0}}$ |
| 25 | PB3 | PB3/ $\overline{\text{IRQ1}}$ / $\overline{\text{POE1}}$ / $\overline{\text{SDA0}}$ | PB3 | PB3/ $\overline{\text{IRQ1}}$ / $\overline{\text{POE1}}$ / $\overline{\text{SDA0}}$ |
| 26 | PB4 | PB4/ $\overline{\text{IRQ2}}$ / $\overline{\text{POE2}}$ / $\overline{\text{CS6}}^{*3}$ | PB4 | PB4/ $\overline{\text{IRQ2}}$ / $\overline{\text{POE2}}$ / $\overline{\text{CS6}}^{*3}$ |
| 27 | $\overline{\text{ASEBRKAK}}^{*1}$ | $\overline{\text{ASEBRKAK}}^{*1}$ | $\overline{\text{ASEBRKAK}}^{*1}$ | $\overline{\text{ASEBRKAK}}^{*1}$ |
| 28 | PB5 | PB5/ $\overline{\text{IRQ3}}$ / $\overline{\text{POE3}}$ / $\overline{\text{CS7}}^{*3}$ | PB5 | PB5/ $\overline{\text{IRQ3}}$ / $\overline{\text{POE3}}$ / $\overline{\text{CS7}}^{*3}$ |
| 29 | PB6 | PB6/ $\overline{\text{IRQ4}}$ /A18/ $\overline{\text{BACK}}$ | PB6 | PB6/ $\overline{\text{IRQ4}}$ /A18/ $\overline{\text{BACK}}$ |
| 30 | PB7 | PB7/ $\overline{\text{IRQ5}}$ /A19/ $\overline{\text{BREQ}}$ | PB7 | PB7/ $\overline{\text{IRQ5}}$ /A19/ $\overline{\text{BREQ}}$ |
| 31 | PB8 | PB8/ $\overline{\text{IRQ6}}$ /A20/ $\overline{\text{WAIT}}$ | PB8 | PB8/ $\overline{\text{IRQ6}}$ /A20/ $\overline{\text{WAIT}}$ |
| 32 | PB9 | PB9/ $\overline{\text{IRQ7}}$ /A21/ $\overline{\text{ADTRG}}$ | PB9 | PB9/ $\overline{\text{IRQ7}}$ /A21/ $\overline{\text{ADTRG}}$ |
| 33 | $\overline{\text{DBGMD}}^{*1}$ | $\overline{\text{DBGMD}}^{*1}$ | $\overline{\text{DBGMD}}^{*1}$ | $\overline{\text{DBGMD}}^{*1}$ |
| 34 | PA14 | PA14/ $\overline{\text{RD}}$ | PA14 | PA14/ $\overline{\text{RD}}$ |
| 35 | $\overline{\text{WDTOVF}}$ | $\overline{\text{WDTOVF}}$ | $\overline{\text{WDTOVF}}$ | $\overline{\text{WDTOVF}}$ |
| 36 | PA13 | PA13/ $\overline{\text{WRH}}$ | PA13 | PA13/ $\overline{\text{WRH}}$ |
| 38 | PA12 | PA12/ $\overline{\text{WRL}}$ | PA12 | PA12/ $\overline{\text{WRL}}$ |
| 40 | PA11 | PA11/ $\overline{\text{CS1}}$ | PA11 | PA11/ $\overline{\text{CS1}}$ |
| 41 | PA10 | PA10/ $\overline{\text{CS0}}$ | PA10 | PA10/ $\overline{\text{CS0}}$ |
| 42 | PA9 | PA9/ $\overline{\text{TCLKD}}$ / $\overline{\text{IRQ3}}$ | PA9 | PA9/ $\overline{\text{TCLKD}}$ / $\overline{\text{IRQ3}}$ |
| 43 | PA8 | PA8/ $\overline{\text{TCLKC}}$ / $\overline{\text{IRQ2}}$ | PA8 | PA8/ $\overline{\text{TCLKC}}$ / $\overline{\text{IRQ2}}$ |
| 44 | PA7 | PA7/ $\overline{\text{TCLKB}}$ / $\overline{\text{CS3}}$ | PA7 | PA7/ $\overline{\text{TCLKB}}$ / $\overline{\text{CS3}}$ |
| 45 | PA6 | PA6/ $\overline{\text{TCLKA}}$ / $\overline{\text{CS2}}$ | PA6 | PA6/ $\overline{\text{TCLKA}}$ / $\overline{\text{CS2}}$ |
| 46 | PA5 | PA5/ $\overline{\text{SCK1}}$ / $\overline{\text{DREQ1}}$ / $\overline{\text{IRQ1}}$ | PA5 | PA5/ $\overline{\text{SCK1}}$ / $\overline{\text{DREQ1}}$ / $\overline{\text{IRQ1}}$ |
| 47 | PA4 | PA4/ $\overline{\text{TXD1}}$ | PA4 | PA4/ $\overline{\text{TXD1}}$ |
| 48 | PA3 | PA3/ $\overline{\text{RXD1}}$ | PA3 | PA3/ $\overline{\text{RXD1}}$ |
| 49 | PA2 | PA2/ $\overline{\text{SCK0}}$ / $\overline{\text{DREQ0}}$ / $\overline{\text{IRQ0}}$ | PA2 | PA2/ $\overline{\text{SCK0}}$ / $\overline{\text{DREQ0}}$ / $\overline{\text{IRQ0}}$ |
| 50 | PA1 | PA1/ $\overline{\text{TXD0}}$ | PA1 | PA1/ $\overline{\text{TXD0}}$ |
| 51 | PA0 | PA0/ $\overline{\text{RXD0}}$ | PA0 | PA0/ $\overline{\text{RXD0}}$ |
| 52 | PD15 | PD15/D15/ $\overline{\text{AUDSYNC}}^{*1}$ | PD15 | PD15/D15/ $\overline{\text{AUDSYNC}}^{*1}$ |
| 53 | PD14 | PD14/D14/ $\overline{\text{AUDACK}}^{*1}$ | PD14 | PD14/D14/ $\overline{\text{AUDACK}}^{*1}$ |
| 54 | PD13 | PD13/D13/ $\overline{\text{AUDMD}}^{*1}$ | PD13 | PD13/D13/ $\overline{\text{AUDMD}}^{*1}$ |
| 56 | PD12 | PD12/D12/ $\overline{\text{AUDRST}}^{*1}$ | PD12 | PD12/D12/ $\overline{\text{AUDRST}}^{*1}$ |
| 57 | PD11 | PD11/D11/ $\overline{\text{AUDATA3}}^{*1}$ | PD11 | PD11/D11/ $\overline{\text{AUDATA3}}^{*1}$ |
| 58 | PD10 | PD10/D10/ $\overline{\text{AUDATA2}}^{*1}$ | PD10 | PD10/D10/ $\overline{\text{AUDATA2}}^{*1}$ |

| Pin No. | Pin Name | | | |
|---------|--|-------------------------------------|--|-------------------------------------|
| | On-Chip ROM Enabled (MCU Mode 2) | | Single Chip Mode (MCU Mode 3) | |
| SH7144 | Initial Function | PFC Selected Function Possibilities | Initial Function | PFC Selected Function Possibilities |
| 59 | PD9 | PD9/D9/AUDATA1* ¹ | PD9 | PD9/D9/AUDATA1* ¹ |
| 60 | PD8 | PD8/D8/AUDATA0* ¹ | PD8 | PD8/D8/AUDATA0* ¹ |
| 62 | PD7 | PD7/D7 | PD7 | PD7/D7 |
| 63 | PD6 | PD6/D6 | PD6 | PD6/D6 |
| 64 | PD5 | PD5/D5 | PD5 | PD5/D5 |
| 66 | PD4 | PD4/D4 | PD4 | PD4/D4 |
| 67 | PD3 | PD3/D3 | PD3 | PD3/D3 |
| 68 | PD2 | PD2/D2 | PD2 | PD2/D2 |
| 69 | PD1 | PD1/D1 | PD1 | PD1/D1 |
| 70 | PD0 | PD0/D0 | PD0 | PD0/D0 |
| 72 | XTAL | XTAL | XTAL | XTAL |
| 73 | MD3 | MD3 | MD3 | MD3 |
| 74 | EXTAL | EXTAL | EXTAL | EXTAL |
| 75 | MD2 | MD2 | MD2 | MD2 |
| 76 | NMI | NMI | NMI | NMI |
| 77 | FWP* ¹ | FWP* ¹ | FWP* ¹ | FWP* ¹ |
| 78 | MD1 | MD1 | MD1 | MD1 |
| 79 | MD0 | MD0 | MD0 | MD0 |
| 83 | CK | PA15/CK | PA15 | PA15/CK |
| 84 | $\overline{\text{RES}}$ | $\overline{\text{RES}}$ | $\overline{\text{RES}}$ | $\overline{\text{RES}}$ |
| 85 | PE0/(TMS* ¹ * ²) | PE0/TIOC0A/DREQ0 | PE0/(TMS* ¹ * ²) | PE0/TIOC0A/DREQ0 |
| 86 | PE1/(TRST* ¹ * ²) | PE1/TIOC0B/DRAK0 | PE1/(TRST* ¹ * ²) | PE1/TIOC0B/DRAK0 |
| 87 | PE2/(TDI* ¹ * ²) | PE2/TIOC0C/DREQ1 | PE2/(TDI* ¹ * ²) | PE2/TIOC0C/DREQ1 |
| 88 | PE3/(TDO* ¹ * ²) | PE3/TIOC0D/DRAK1 | PE3/(TDO* ¹ * ²) | PE3/TIOC0D/DRAK1 |
| 89 | PE4/(TCK* ¹ * ²) | PE4/TIOC1A/RXD3 | PE4/(TCK* ¹ * ²) | PE4/TIOC1A/RXD3 |
| 91 | PF0/AN0 | PF0/AN0 | PF0/AN0 | PF0/AN0 |
| 92 | PF1/AN1 | PF1/AN1 | PF1/AN1 | PF1/AN1 |
| 93 | PF2/AN2 | PF2/AN2 | PF2/AN2 | PF2/AN2 |
| 94 | PF3/AN3 | PF3/AN3 | PF3/AN3 | PF3/AN3 |
| 95 | PF4/AN4 | PF4/AN4 | PF4/AN4 | PF4/AN4 |
| 96 | PF5/AN5 | PF5/AN5 | PF5/AN5 | PF5/AN5 |
| 98 | PF6/AN6 | PF6/AN6 | PF6/AN6 | PF6/AN6 |

| Pin No. | Pin Name | | | |
|---------|----------------------------------|-------------------------------------|-------------------------------|-------------------------------------|
| | On-Chip ROM Enabled (MCU Mode 2) | | Single Chip Mode (MCU Mode 3) | |
| | Initial Function | PFC Selected Function Possibilities | Initial Function | PFC Selected Function Possibilities |
| SH7144 | | | | |
| 99 | PF7/AN7 | PF7/AN7 | PF7/AN7 | PF7/AN7 |
| 102 | PE5 | PE5/TIOC1B/TXD3 | PE5 | PE5/TIOC1B/TXD3 |
| 104 | PE6 | PE6/TIOC2A/SCK3 | PE6 | PE6/TIOC2A/SCK3 |
| 105 | PE7 | PE7/TIOC2B/RXD2 | PE7 | PE7/TIOC2B/RXD2 |
| 106 | PE8 | PE8/TIOC3A/ SCK2 | PE8 | PE8/TIOC3A/SCK2 |
| 107 | PE9 | PE9/TIOC3B/ SCK3 | PE9 | PE9/TIOC3B/SCK3 |
| 108 | PE10 | PE10/TIOC3C/TXD2 | PE10 | PE10/TIOC3C/TXD2 |
| 110 | PE11 | PE11/TIOC3D/RXD3 | PE11 | PE11/TIOC3D/RXD3 |
| 111 | PE12 | PE12/TIOC4A/TXD3 | PE12 | PE12/TIOC4A/TXD3 |
| 112 | PE13 | PE13/TIOC4B/MRES | PE13 | PE13/TIOC4B/MRES |

- Notes:
1. F-ZTAT version only
 2. Fixed to TMS, TRST, TDI, TDO, and TCK when using the E10A (in DBGMD = high).
 3. Masked ROM version and ROM less version only

Table 17.14 SH7145 Pin Functions in Each Mode (1)

| Pin No. | Pin Name | | | |
|--|-----------------------------------|-------------------------------------|-----------------------------------|-------------------------------------|
| | On-Chip ROM Disabled (MCU Mode 0) | | On-Chip ROM Disabled (MCU Mode 1) | |
| | Initial Function | PFC Selected Function Possibilities | Initial Function | PFC Selected Function Possibilities |
| SH7145 | | | | |
| 12, 26, 40, 63, 77, 85, 112, 135 | Vcc | Vcc | Vcc | Vcc |
| 6, 14, 28, 55, 61, 71, 79, 87, 93, 117, 129, 141 | Vss | Vss | Vss | Vss |
| 128 | AVcc | AVcc | AVcc | AVcc |
| 127 | AVREF | AVREF | AVREF | AVREF |
| 124 | AVss | AVss | AVss | AVss |
| 104 | PLLVcc | PLLVcc | PLLVcc | PLLVcc |
| 105 | PLLCAP | PLLCAP | PLLCAP | PLLCAP |
| 106 | PLLVss | PLLVss | PLLVss | PLLVss |
| 1 | PA23 | PA23/WRHH | WRHH | PA23/WRHH |
| 2 | PE14 | PE14/TIOC4C/DACK0 | PE14 | PE14/TIOC4C/DACK0 |
| 3 | PA22 | PA22/WRHL | WRHL | PA22/WRHL |
| 4 | PA21 | PA21/CS5* ³ | PA21 | PA21/CS5* ³ |
| 5 | PE15 | PE15/TIOC4D/DACK1/IRQOUT | PE15 | PE15/TIOC4D/DACK1/IRQOUT |
| 7 | A0 | PC0/A0 | A0 | PC0/A0 |
| 8 | A1 | PC1/A1 | A1 | PC1/A1 |
| 9 | A2 | PC2/A2 | A2 | PC2/A2 |
| 10 | A3 | PC3/A3 | A3 | PC3/A3 |
| 11 | A4 | PC4/A4 | A4 | PC4/A4 |
| 13 | A5 | PC5/A5 | A5 | PC5/A5 |
| 15 | A6 | PC6/A6 | A6 | PC6/A6 |
| 16 | A7 | PC7/A7 | A7 | PC7/A7 |
| 17 | A8 | PC8/A8 | A8 | PC8/A8 |
| 18 | A9 | PC9/A9 | A9 | PC9/A9 |
| 19 | A10 | PC10/A10 | A10 | PC10/A10 |
| 20 | A11 | PC11/A11 | A11 | PC11/A11 |
| 21 | A12 | PC12/A12 | A12 | PC12/A12 |

17. Pin Function Controller (PFC)

Pin Name

| Pin No. | On-Chip ROM Disabled (MCU Mode 0) | | On-Chip ROM Disabled (MCU Mode 1) | |
|---------|-----------------------------------|--|-----------------------------------|--|
| | Initial Function | PFC Selected Function Possibilities | Initial Function | PFC Selected Function Possibilities |
| SH7145 | | | | |
| 22 | A13 | PC13/A13 | A13 | PC13/A13 |
| 23 | A14 | PC14/A14 | A14 | PC14/A14 |
| 24 | A15 | PC15/A15 | A15 | PC15/A15 |
| 25 | A16 | PB0/A16 | A16 | PB0/A16 |
| 27 | A17 | PB1/A17 | A17 | PB1/A17 |
| 29 | PA20 | PA20/ $\overline{CS4}^{*3}$ | PA20 | PA20/ $\overline{CS4}^{*3}$ |
| 30 | PA19 | PA19/ \overline{BACK} /DRAK1 | PA19 | PA19/ \overline{BACK} /DRAK1 |
| 31 | PB2 | PB2/ $\overline{IRQ0}$ / $\overline{POE0}$ / $\overline{SCL0}$ | PB2 | PB2/ $\overline{IRQ0}$ / $\overline{POE0}$ / $\overline{SCL0}$ |
| 32 | PB3 | PB3/ $\overline{IRQ1}$ / $\overline{POE1}$ / $\overline{SDA0}$ | PB3 | PB3/ $\overline{IRQ1}$ / $\overline{POE1}$ / $\overline{SDA0}$ |
| 33 | PA18 | PA18/ \overline{BREQ} /DRAK0 | PA18 | PA18/ \overline{BREQ} /DRAK0 |
| 34 | PB4 | PB4/ $\overline{IRQ2}$ / $\overline{POE2}$ / $\overline{CS6}^{*3}$ | PB4 | PB4/ $\overline{IRQ2}$ / $\overline{POE2}$ / $\overline{CS6}^{*3}$ |
| 35 | $\overline{ASEBRKAK}^{*1}$ | $\overline{ASEBRKAK}^{*1}$ | $\overline{ASEBRKAK}^{*1}$ | $\overline{ASEBRKAK}^{*1}$ |
| 36 | PB5 | PB5/ $\overline{IRQ3}$ / $\overline{POE3}$ / $\overline{CS7}^{*3}$ | PB5 | PB5/ $\overline{IRQ3}$ / $\overline{POE3}$ / $\overline{CS7}^{*3}$ |
| 37 | PB6 | PB6/ $\overline{IRQ4}$ /A18/ \overline{BACK} | PB6 | PB6/ $\overline{IRQ4}$ /A18/ \overline{BACK} |
| 38 | PB7 | PB7/ $\overline{IRQ5}$ /A19/ \overline{BREQ} | PB7 | PB7/ $\overline{IRQ5}$ /A19/ \overline{BREQ} |
| 39 | PB8 | PB8/ $\overline{IRQ6}$ /A20/ \overline{WAIT} | PB8 | PB8/ $\overline{IRQ6}$ /A20/ \overline{WAIT} |
| 41 | PB9 | PB9/ $\overline{IRQ7}$ /A21/ \overline{ADTRG} | PB9 | PB9/ $\overline{IRQ7}$ /A21/ \overline{ADTRG} |
| 42 | \overline{DBGMD}^{*1} | \overline{DBGMD}^{*1} | \overline{DBGMD}^{*1} | \overline{DBGMD}^{*1} |
| 43 | \overline{RD} | PA14/ \overline{RD} | \overline{RD} | PA14/ \overline{RD} |
| 44 | \overline{WDTOVF} | \overline{WDTOVF} | \overline{WDTOVF} | \overline{WDTOVF} |
| 45 | PD31 | PD31/D31/ \overline{ADTRG} | D31 | PD31/D31/ \overline{ADTRG} |
| 46 | PD30 | PD30/D30/ \overline{IRQOUT} | D30 | PD30/D30/ \overline{IRQOUT} |
| 47 | \overline{WRH} | PA13/ \overline{WRH} | \overline{WRH} | PA13/ \overline{WRH} |
| 48 | \overline{WRL} | PA12/ \overline{WRL} | \overline{WRL} | PA12/ \overline{WRL} |
| 49 | $\overline{CS1}$ | PA11/ $\overline{CS1}$ | $\overline{CS1}$ | PA11/ $\overline{CS1}$ |
| 50 | $\overline{CS0}$ | PA10/ $\overline{CS0}$ | $\overline{CS0}$ | PA10/ $\overline{CS0}$ |
| 51 | PA9 | PA9/ \overline{TCLKD} / $\overline{IRQ3}$ | PA9 | PA9/ \overline{TCLKD} / $\overline{IRQ3}$ |
| 52 | PA8 | PA8/ \overline{TCLKC} / $\overline{IRQ2}$ | PA8 | PA8/ \overline{TCLKC} / $\overline{IRQ2}$ |
| 53 | PA7 | PA7/ \overline{TCLKB} / $\overline{CS3}$ | PA7 | PA7/ \overline{TCLKB} / $\overline{CS3}$ |
| 54 | PA6 | PA6/ \overline{TCLKA} / $\overline{CS2}$ | PA6 | PA6/ \overline{TCLKA} / $\overline{CS2}$ |
| 56 | PD29 | PD29/D29/ $\overline{CS3}$ | D29 | PD29/D29/ $\overline{CS3}$ |
| 57 | PD28 | PD28/D28/ $\overline{CS2}$ | D28 | PD28/D28/ $\overline{CS2}$ |

| Pin No. | Pin Name | | | |
|---------|-----------------------------------|---|-----------------------------------|---|
| | On-Chip ROM Disabled (MCU Mode 0) | | On-Chip ROM Disabled (MCU Mode 1) | |
| SH7145 | Initial Function | PFC Selected Function Possibilities | Initial Function | PFC Selected Function Possibilities |
| 58 | PD27 | PD27/D27/DACK1 | D27 | PD27/D27/DACK1 |
| 59 | PD26 | PD26/D26/DACK0 | D26 | PD26/D26/DACK0 |
| 60 | PD25 | PD25/D25/DREQ1 | D25 | PD25/D25/DREQ1 |
| 62 | PD24 | PD24/D24/DREQ0 | D24 | PD24/D24/DREQ0 |
| 64 | PD23 | PD23/D23/IRQ7/ AUDSYNC* ¹ | D23 | PD23/D23/IRQ7/ AUDSYNC* ¹ |
| 65 | PD22 | PD22/D22/IRQ6/AUDCK* ¹ | D22 | PD22/D22/IRQ6/AUDCK* ¹ |
| 66 | PD21 | PD21/D21/IRQ5/AUDMD* ¹ | D21 | PD21/D21/IRQ5/AUDMD* ¹ |
| 67 | PD20 | PD20/D20/IRQ4/AUDRST* ¹ | D20 | PD20/D20/IRQ4/AUDRST* ¹ |
| 68 | PD19 | PD19/D19/IRQ3/ AUDATA3* ¹ | D19 | PD19/D19/IRQ3/ AUDATA3* ¹ |
| 69 | PD18 | PD18/D18/IRQ2/ AUDATA2* ¹ | D18 | PD18/D18/IRQ2/ AUDATA2* ¹ |
| 70 | PD17 | PD17/D17/IRQ1/ AUDATA1* ¹ | D17 | PD17/D17/IRQ1/ AUDATA1* ¹ |
| 72 | PD16 | PD16/D16/IRQ0/ AUDATA0* ¹ | D16 | PD16/D16/IRQ0/ AUDATA0* ¹ |
| 73 | D15 | PD15/D15 | D15 | PD15/D15 |
| 74 | D14 | PD14/D14 | D14 | PD14/D14 |
| 75 | D13 | PD13/D13 | D13 | PD13/D13 |
| 76 | D12 | PD12/D12 | D12 | PD12/D12 |
| 78 | D11 | PD11/D11 | D11 | PD11/D11 |
| 80 | D10 | PD10/D10 | D10 | PD10/D10 |
| 81 | D9 | PD9/D9 | D9 | PD9/D9 |
| 82 | D8 | PD8/D8 | D8 | PD8/D8 |
| 83 | D7 | PD7/D7 | D7 | PD7/D7 |
| 84 | D6 | PD6/D6 | D6 | PD6/D6 |
| 86 | D5 | PD5/D5 | D5 | PD5/D5 |
| 88 | D4 | PD4/D4 | D4 | PD4/D4 |
| 89 | D3 | PD3/D3 | D3 | PD3/D3 |
| 90 | D2 | PD2/D2 | D2 | PD2/D2 |
| 91 | D1 | PD1/D1 | D1 | PD1/D1 |
| 92 | D0 | PD0/D0 | D0 | PD0/D0 |

17. Pin Function Controller (PFC)

Pin Name

| Pin No. | On-Chip ROM Disabled (MCU Mode 0) | | On-Chip ROM Disabled (MCU Mode 1) | |
|---------|-----------------------------------|--|-----------------------------------|--|
| | Initial Function | PFC Selected Function Possibilities | Initial Function | PFC Selected Function Possibilities |
| SH7145 | | | | |
| 94 | XTAL | XTAL | XTAL | XTAL |
| 95 | MD3 | MD3 | MD3 | MD3 |
| 96 | EXTAL | EXTAL | EXTAL | EXTAL |
| 97 | MD2 | MD2 | MD2 | MD2 |
| 98 | NMI | NMI | NMI | NMI |
| 99 | FWP* ¹ | FWP* ¹ | FWP* ¹ | FWP* ¹ |
| 100 | PA16 | PA16/AUDSYNC* ¹ | PA16 | PA16/AUDSYNC* ¹ |
| 101 | PA17 | PA17/WAIT | PA17 | PA17/WAIT |
| 102 | MD1 | MD1 | MD1 | MD1 |
| 103 | MD0 | MD0 | MD0 | MD0 |
| 107 | CK | PA15/CK | CK | PA15/CK |
| 108 | RES | RES | RES | RES |
| 109 | PE0 | PE0/TIOC0A/DREQ0/ AUDCK* ¹ | PE0 | PE0/TIOC0A/DREQ0/ AUDCK* ¹ |
| 110 | PE1 | PE1/TIOC0B/DRAK0/ AUDMD* ¹ | PE1 | PE1/TIOC0B/DRAK0/ AUDMD* ¹ |
| 111 | PE2 | PE2/TIOC0C/DREQ1/ AUDRST* ¹ | PE2 | PE2/TIOC0C/DREQ1/ AUDRST* ¹ |
| 113 | PE3 | PE3/TIOC0D/DRAK1/ AUDATA3* ¹ | PE3 | PE3/TIOC0D/DRAK1/ AUDATA3* ¹ |
| 114 | PE4 | PE4/TIOC1A/RXD3/ AUDATA2* ¹ | PE4 | PE4/TIOC1A/RXD3/ AUDATA2* ¹ |
| 115 | PE5 | PE5/TIOC1B/TXD3/ AUDATA1* ¹ | PE5 | PE5/TIOC1B/TXD3 /AUDATA1* ¹ |
| 116 | PE6 | PE6/TIOC2A/SCK3/ AUDATA0* ¹ | PE6 | PE6/TIOC2A/SCK3 /AUDATA0* ¹ |
| 118 | PF0/AN0 | PF0/AN0 | PF0/AN0 | PF0/AN0 |
| 119 | PF1/AN1 | PF1/AN1 | PF1/AN1 | PF1/AN1 |
| 120 | PF2/AN2 | PF2/AN2 | PF2/AN2 | PF2/AN2 |
| 121 | PF3/AN3 | PF3/AN3 | PF3/AN3 | PF3/AN3 |
| 122 | PF4/AN4 | PF4/AN4 | PF4/AN4 | PF4/AN4 |
| 123 | PF5/AN5 | PF5/AN5 | PF5/AN5 | PF5/AN5 |
| 125 | PF6/AN6 | PF6/AN6 | PF6/AN6 | PF6/AN6 |
| 126 | PF7/AN7 | PF7/AN7 | PF7/AN7 | PF7/AN7 |

| Pin No. | Pin Name | | | |
|---------|--|-------------------------------------|--|-------------------------------------|
| | On-Chip ROM Disabled (MCU Mode 0) | | On-Chip ROM Disabled (MCU Mode 1) | |
| | Initial Function | PFC Selected Function Possibilities | Initial Function | PFC Selected Function Possibilities |
| SH7145 | PA0 | PA0/RXD0 | PA0 | PA0/RXD0 |
| 130 | PA0 | PA0/RXD0 | PA0 | PA0/RXD0 |
| 131 | PA1 | PA1/TXD0 | PA1 | PA1/TXD0 |
| 132 | PA2 | PA2/SCK0/DREQ0/IRQ0 | PA2 | PA2/SCK0/DREQ0/IRQ0 |
| 133 | PA3 | PA3/RXD1 | PA3 | PA3/RXD1 |
| 134 | PA4 | PA4/TXD1 | PA4 | PA4/TXD1 |
| 136 | PA5 | PA5/SCK1/DREQ1/IRQ1 | PA5 | PA5/SCK1/DREQ1/IRQ1 |
| 137 | PE7 | PE7/TIOC2B/RXD2 | PE7 | PE7/TIOC2B/RXD2 |
| 138 | PE8/(TMS* ¹ * ²) | PE8/TIOC3A/SCK2 | PE8/(TMS* ¹ * ²) | PE8/TIOC3A/SCK2 |
| 139 | PE9/(TRST* ¹ * ²) | PE9/TIOC3B/SCK3 | PE9/(TRST* ¹ * ²) | PE9/TIOC3B/SCK3 |
| 140 | PE10/(TDI* ¹ * ²) | PE10/TIOC3C/TXD2 | PE10/(TDI* ¹ * ²) | PE10/TIOC3C/TXD2 |
| 142 | PE11/(TDO* ¹ * ²) | PE11/TIOC3D/RXD3 | PE11/(TDO* ¹ * ²) | PE11/TIOC3D/RXD3 |
| 143 | PE12/(TCK* ¹ * ²) | PE12/TIOC4A/TXD3 | PE12/(TCK* ¹ * ²) | PE12/TIOC4A/TXD3 |
| 144 | PE13 | PE13/TIOC4B/MRES | PE13 | PE13/TIOC4B/MRES |

- Notes: 1. F-ZTAT version only
2. Fixed to TMS, TRST, TDI, TDO, and TCK when using the E10A (in DBGMD = high).
3. Masked ROM version and ROM less version only

Table 17.14 SH7145 Pin Functions in Each Mode (2)

| Pin No. | Pin Name | | | |
|--|----------------------------------|-------------------------------------|-------------------------------|-------------------------------------|
| | On-Chip ROM Enabled (MCU Mode 2) | | Single Chip Mode (MCU Mode 3) | |
| | Initial Function | PFC Selected Function Possibilities | Initial Function | PFC Selected Function Possibilities |
| SH7145 | | | | |
| 12, 26, 40, 63, 77, 85, 112, 135 | Vcc | Vcc | Vcc | Vcc |
| 6, 14, 28, 55, 61, 71, 79, 87, 93, 117, 129, 141 | Vss | Vss | Vss | Vss |
| 128 | AVcc | AVcc | AVcc | AVcc |
| 127 | AVREF | AVREF | AVREF | AVREF |
| 124 | AVss | AVss | AVss | AVss |
| 104 | PLLvcc | PLLvcc | PLLvcc | PLLvcc |
| 105 | PLLCAP | PLLCAP | PLLCAP | PLLCAP |
| 106 | PLLvss | PLLvss | PLLvss | PLLvss |
| 1 | PA23 | PA23/WRHH | PA23 | PA23/WRHH |
| 2 | PE14 | PE14/TIOC4C/DACK0 | PE14 | PE14/TIOC4C/DACK0 |
| 3 | PA22 | PA22/WRHL | PA22 | PA22/WRHL |
| 4 | PA21 | PA21/CS5*3 | PA21 | PA21/CS5*3 |
| 5 | PE15 | PE15/TIOC4D/DACK1/IRQOUT | PE15 | PE15/TIOC4D/DACK1/IRQOUT |
| 7 | PC0 | PC0/A0 | PC0 | PC0/A0 |
| 8 | PC1 | PC1/A1 | PC1 | PC1/A1 |
| 9 | PC2 | PC2/A2 | PC2 | PC2/A2 |
| 10 | PC3 | PC3/A3 | PC3 | PC3/A3 |
| 11 | PC4 | PC4/A4 | PC4 | PC4/A4 |
| 13 | PC5 | PC5/A5 | PC5 | PC5/A5 |
| 15 | PC6 | PC6/A6 | PC6 | PC6/A6 |
| 16 | PC7 | PC7/A7 | PC7 | PC7/A7 |
| 17 | PC8 | PC8/A8 | PC8 | PC8/A8 |
| 18 | PC9 | PC9/A9 | PC9 | PC9/A9 |
| 19 | PC10 | PC10/A10 | PC10 | PC10/A10 |
| 20 | PC11 | PC11/A11 | PC11 | PC11/A11 |
| 21 | PC12 | PC12/A12 | PC12 | PC12/A12 |

| Pin No. | Pin Name | | | |
|---------|----------------------------------|--|-------------------------------|--|
| | On-Chip ROM Enabled (MCU Mode 2) | | Single Chip Mode (MCU Mode 3) | |
| | Initial Function | PFC Selected Function Possibilities | Initial Function | PFC Selected Function Possibilities |
| SH7145 | | | | |
| 22 | PC13 | PC13/A13 | PC13 | PC13/A13 |
| 23 | PC14 | PC14/A14 | PC14 | PC14/A14 |
| 24 | PC15 | PC15/A15 | PC15 | PC15/A15 |
| 25 | PB0 | PB0/A16 | PB0 | PB0/A16 |
| 27 | PB1 | PB1/A17 | PB1 | PB1/A17 |
| 29 | PA20 | PA20/ $\overline{CS4}^{*3}$ | PA20 | PA20/ $\overline{CS4}^{*3}$ |
| 30 | PA19 | PA19/BACK/DRAK1 | PA19 | PA19/BACK/DRAK1 |
| 31 | PB2 | PB2/ $\overline{IRQ0}$ / $\overline{POE0}$ / $\overline{SCL0}$ | PB2 | PB2/ $\overline{IRQ0}$ / $\overline{POE0}$ / $\overline{SCL0}$ |
| 32 | PB3 | PB3/ $\overline{IRQ1}$ / $\overline{POE1}$ / $\overline{SDA0}$ | PB3 | PB3/ $\overline{IRQ1}$ / $\overline{POE1}$ / $\overline{SDA0}$ |
| 33 | PA18 | PA18/ \overline{BREQ} /DRAK0 | PA18 | PA18/ \overline{BREQ} /DRAK0 |
| 34 | PB4 | PB4/ $\overline{IRQ2}$ / $\overline{POE2}$ / $\overline{CS6}^{*3}$ | PB4 | PB4/ $\overline{IRQ2}$ / $\overline{POE2}$ / $\overline{CS6}^{*3}$ |
| 35 | $\overline{ASEBRKAK}^{*1}$ | $\overline{ASEBRKAK}^{*1}$ | $\overline{ASEBRKAK}^{*1}$ | $\overline{ASEBRKAK}^{*1}$ |
| 36 | PB5 | PB5/ $\overline{IRQ3}$ / $\overline{POE3}$ / $\overline{CS7}^{*3}$ | PB5 | PB5/ $\overline{IRQ3}$ / $\overline{POE3}$ / $\overline{CS7}^{*3}$ |
| 37 | PB6 | PB6/ $\overline{IRQ4}$ /A18/BACK | PB6 | PB6/ $\overline{IRQ4}$ /A18/BACK |
| 38 | PB7 | PB7/ $\overline{IRQ5}$ /A19/ \overline{BREQ} | PB7 | PB7/ $\overline{IRQ5}$ /A19/ \overline{BREQ} |
| 39 | PB8 | PB8/ $\overline{IRQ6}$ /A20/ \overline{WAIT} | PB8 | PB8/ $\overline{IRQ6}$ /A20/ \overline{WAIT} |
| 41 | PB9 | PB9/ $\overline{IRQ7}$ /A21/ \overline{ADTRG} | PB9 | PB9/ $\overline{IRQ7}$ /A21/ \overline{ADTRG} |
| 42 | DBGMD *1 | DBGMD *1 | DBGMD *1 | DBGMD *1 |
| 43 | PA14 | PA14/ \overline{RD} | PA14 | PA14/ \overline{RD} |
| 44 | \overline{WDTOVF} | \overline{WDTOVF} | \overline{WDTOVF} | \overline{WDTOVF} |
| 45 | PD31 | PD31/D31/ \overline{ADTRG} | PD31 | PD31/D31/ \overline{ADTRG} |
| 46 | PD30 | PD30/D30/ \overline{IRQOUT} | PD30 | PD30/D30/ \overline{IRQOUT} |
| 47 | PA13 | PA13/ \overline{WRH} | PA13 | PA13/ \overline{WRH} |
| 48 | PA12 | PA12/ \overline{WRL} | PA12 | PA12/ \overline{WRL} |
| 49 | PA11 | PA11/ $\overline{CS1}$ | PA11 | PA11/ $\overline{CS1}$ |
| 50 | PA10 | PA10/ $\overline{CS0}$ | PA10 | PA10/ $\overline{CS0}$ |
| 51 | PA9 | PA9/TCLKD/ $\overline{IRQ3}$ | PA9 | PA9/TCLKD/ $\overline{IRQ3}$ |
| 52 | PA8 | PA8/TCLKC/ $\overline{IRQ2}$ | PA8 | PA8/TCLKC/ $\overline{IRQ2}$ |
| 53 | PA7 | PA7/TCLKB/ $\overline{CS3}$ | PA7 | PA7/TCLKB/ $\overline{CS3}$ |
| 54 | PA6 | PA6/TCLKA/ $\overline{CS2}$ | PA6 | PA6/TCLKA/ $\overline{CS2}$ |
| 56 | PD29 | PD29/D29/ $\overline{CS3}$ | PD29 | PD29/D29/ $\overline{CS3}$ |
| 57 | PD28 | PD28/D28/ $\overline{CS2}$ | PD28 | PD28/D28/ $\overline{CS2}$ |

17. Pin Function Controller (PFC)

Pin Name

| Pin No. | On-Chip ROM Enabled (MCU Mode 2) | | Single Chip Mode (MCU Mode 3) | |
|---------|----------------------------------|---|-------------------------------|---|
| | Initial Function | PFC Selected Function Possibilities | Initial Function | PFC Selected Function Possibilities |
| SH7145 | | | | |
| 58 | PD27 | PD27/D27/DACK1 | PD27 | PD27/D27/DACK1 |
| 59 | PD26 | PD26/D26/DACK0 | PD26 | PD26/D26/DACK0 |
| 60 | PD25 | PD25/D25/DREQ1 | PD25 | PD25/D25/DREQ1 |
| 62 | PD24 | PD24/D24/DREQ0 | PD24 | PD24/D24/DREQ0 |
| 64 | PD23 | PD23/D23/IRQ7/ AUDSYNC* ¹ | PD23 | PD23/D23/IRQ7/ AUDSYNC* ¹ |
| 65 | PD22 | PD22/D22/IRQ6/AUDCK* ¹ | PD22 | PD22/D22/IRQ6/AUDCK* ¹ |
| 66 | PD21 | PD21/D21/IRQ5/AUDMD* ¹ | PD21 | PD21/D21/IRQ5/AUDMD* ¹ |
| 67 | PD20 | PD20/D20/IRQ4/AUDRST * ¹ | PD20 | PD20/D20/IRQ4/AUDRST* ¹ |
| 68 | PD19 | PD19/D19/IRQ3/ AUDATA3* ¹ | PD19 | PD19/D19/IRQ3/ AUDATA3* ¹ |
| 69 | PD18 | PD18/D18/IRQ2/ AUDATA2* ¹ | PD18 | PD18/D18/IRQ2/ AUDATA2* ¹ |
| 70 | PD17 | PD17/D17/IRQ1/ AUDATA1* ¹ | PD17 | PD17/D17/IRQ1/ AUDATA1* ¹ |
| 72 | PD16 | PD16/D16/IRQ0/ AUDATA0* ¹ | PD16 | PD16/D16/IRQ0/ AUDATA0* ¹ |
| 73 | PD15 | PD15/D15 | PD15 | PD15/D15 |
| 74 | PD14 | PD14/D14 | PD14 | PD14/D14 |
| 75 | PD13 | PD13/D13 | PD13 | PD13/D13 |
| 76 | PD12 | PD12/D12 | PD12 | PD12/D12 |
| 78 | PD11 | PD11/D11 | PD11 | PD11/D11 |
| 80 | PD10 | PD10/D10 | PD10 | PD10/D10 |
| 81 | PD9 | PD9/D9 | PD9 | PD9/D9 |
| 82 | PD8 | PD8/D8 | PD8 | PD8/D8 |
| 83 | PD7 | PD7/D7 | PD7 | PD7/D7 |
| 84 | PD6 | PD6/D6 | PD6 | PD6/D6 |
| 86 | PD5 | PD5/D5 | PD5 | PD5/D5 |
| 88 | PD4 | PD4/D4 | PD4 | PD4/D4 |
| 89 | PD3 | PD3/D3 | PD3 | PD3/D3 |
| 90 | PD2 | PD2/D2 | PD2 | PD2/D2 |
| 91 | PD1 | PD1/D1 | PD1 | PD1/D1 |
| 92 | PD0 | PD0/D0 | PD0 | PD0/D0 |

| Pin No. | Pin Name | | | |
|---------|----------------------------------|--|-------------------------------|--|
| | On-Chip ROM Enabled (MCU Mode 2) | | Single Chip Mode (MCU Mode 3) | |
| | Initial Function | PFC Selected Function Possibilities | Initial Function | PFC Selected Function Possibilities |
| SH7145 | | | | |
| 94 | XTAL | XTAL | XTAL | XTAL |
| 95 | MD3 | MD3 | MD3 | MD3 |
| 96 | EXTAL | EXTAL | EXTAL | EXTAL |
| 97 | MD2 | MD2 | MD2 | MD2 |
| 98 | NMI | NMI | NMI | NMI |
| 99 | FWP* ¹ | FWP* ¹ | FWP* ¹ | FWP* ¹ |
| 100 | PA16 | PA16/AUDSYNC* ¹ | PA16 | PA16/AUDSYNC* ¹ |
| 101 | PA17 | PA17/WAIT | PA17 | PA17/WAIT |
| 102 | MD1 | MD1 | MD1 | MD1 |
| 103 | MD0 | MD0 | MD0 | MD0 |
| 107 | CK | PA15/CK | PA15 | PA15/CK |
| 108 | RES | RES | RES | RES |
| 109 | PE0 | PE0/TIOC0A/DREQ0/ AUDCK* ¹ | PE0 | PE0/TIOC0A/DREQ0/ AUDCK* ¹ |
| 110 | PE1 | PE1/TIOC0B/DRAK0/ AUDMD* ¹ | PE1 | PE1/TIOC0B/DRAK0/ AUDMD* ¹ |
| 111 | PE2 | PE2/TIOC0C/DREQ1/ AUDRST* ¹ | PE2 | PE2/TIOC0C/DREQ1/ AUDRST* ¹ |
| 113 | PE3 | PE3/TIOC0D/DRAK1/ AUDATA3* ¹ | PE3 | PE3/TIOC0D/DRAK1/ AUDATA3* ¹ |
| 114 | PE4 | PE4/TIOC1A/RXD3/ AUDATA2* ¹ | PE4 | PE4/TIOC1A/RXD3/ AUDATA2* ¹ |
| 115 | PE5 | PE5/TIOC1B/TXD3/ AUDATA1* ¹ | PE5 | PE5/TIOC1B/TXD3/ AUDATA1* ¹ |
| 116 | PE6 | PE6/TIOC2A/SCK3/ AUDATA0* ¹ | PE6 | PE6/TIOC2A/SCK3/ AUDATA0* ¹ |
| 118 | PF0/AN0 | PF0/AN0 | PF0/AN0 | PF0/AN0 |
| 119 | PF1/AN1 | PF1/AN1 | PF1/AN1 | PF1/AN1 |
| 120 | PF2/AN2 | PF2/AN2 | PF2/AN2 | PF2/AN2 |
| 121 | PF3/AN3 | PF3/AN3 | PF3/AN3 | PF3/AN3 |
| 122 | PF4/AN4 | PF4/AN4 | PF4/AN4 | PF4/AN4 |
| 123 | PF5/AN5 | PF5/AN5 | PF5/AN5 | PF5/AN5 |
| 125 | PF6/AN6 | PF6/AN6 | PF6/AN6 | PF6/AN6 |
| 126 | PF7/AN7 | PF7/AN7 | PF7/AN7 | PF7/AN7 |

17. Pin Function Controller (PFC)

| Pin No. | Pin Name | | | |
|---------|--|-------------------------------------|--|-------------------------------------|
| | On-Chip ROM Enabled (MCU Mode 2) | | Single Chip Mode (MCU Mode 3) | |
| | Initial Function | PFC Selected Function Possibilities | Initial Function | PFC Selected Function Possibilities |
| SH7145 | PA0 | PA0/RXD0 | PA0 | PA0/RXD0 |
| 130 | PA0 | PA0/RXD0 | PA0 | PA0/RXD0 |
| 131 | PA1 | PA1/TXD0 | PA1 | PA1/TXD0 |
| 132 | PA2 | PA2/SCK0/DREQ0/IRQ0 | PA2 | PA2/SCK0/DREQ0/IRQ0 |
| 133 | PA3 | PA3/RXD1 | PA3 | PA3/RXD1 |
| 134 | PA4 | PA4/TXD1 | PA4 | PA4/TXD1 |
| 136 | PA5 | PA5/SCK1/DREQ1/IRQ1 | PA5 | PA5/SCK1/DREQ1/IRQ1 |
| 137 | PE7 | PE7/TIOC2B/RXD2 | PE7 | PE7/TIOC2B/RXD2 |
| 138 | PE8/(TMS* ¹ * ²) | PE8/TIOC3A/SCK2 | PE8/(TMS* ¹ * ²) | PE8/TIOC3A/SCK2 |
| 139 | PE9/(TRST* ¹ * ²) | PE9/TIOC3B/SCK3 | PE9/(TRST* ¹ * ²) | PE9/TIOC3B/SCK3 |
| 140 | PE10/(TDI* ¹ * ²) | PE10/TIOC3C/TXD2 | PE10/(TDI* ¹ * ²) | PE10/TIOC3C/TXD2 |
| 142 | PE11/(TDO* ¹ * ²) | PE11/TIOC3D/RXD3 | PE11/(TDO* ¹ * ²) | PE11/TIOC3D/RXD3 |
| 143 | PE12/(TCK* ¹ * ²) | PE12/TIOC4A/TXD3 | PE12/(TCK* ¹ * ²) | PE12/TIOC4A/TXD3 |
| 144 | PE13 | PE13/TIOC4B/MRES | PE13 | PE13/TIOC4B/MRES |

- Notes:
1. F-ZTAT version only
 2. Fixed to TMS, TRST, TDI, TDO, and TCK when using the E10A (in DBGMD = high).
 3. Masked ROM version and ROM less version only

17.1 Register Descriptions

The PFC has the following registers. For details on the addresses of the registers and their states during each process, see section 25, List of Registers.

- Port A I/O register H (PAIORH)*
- Port A I/O register L (PAIORL)
- Port A control register H (PACRH)*
- Port A control register L2 (PACRL2)
- Port A control register L1 (PACRL1)
- Port B I/O register (PBIOR)
- Port B control register 1 (PBCR1)
- Port B control register 2 (PBCR2)
- Port C I/O register (PCIOR)
- Port C control register (PCCR)
- Port D I/O register H (PDIORH)*
- Port D I/O register L (PDIORL)
- Port D control register H1 (PDCRH1)*
- Port D control register H2 (PDCRH2)*
- Port D control register L1 (PDCRL1)
- Port D control register L2 (PDCRL2)
- Port E I/O register L (PEIORL)
- Port E control register L1 (PECRL1)
- Port E control register L2 (PECRL2)
- High-current port control register (PPCR)

Note: * Can be set only in SH7145. These are not available in SH7144.

17.1.1 Port A I/O Register L, H (PAIORL, PAIORH)

The port A I/O register L, H (PAIORL, PAIORH) are 16-bit readable/writable registers that are used to set the pins on port A as inputs or outputs. Bits PA23IOR to PA0IOR correspond to pins PA23 to PA0 (names of multiplexed pins are here given as port names and pin numbers alone). PAIORL is enabled when the port A pins are functioning as general-purpose inputs/outputs (PA15 to PA0), and SCK0 and SCK1 pins are functioning as inputs/outputs of SCI. In other states, PAIORL is disabled. PAIORH is enabled when the port A pins are functioning as general-purpose input/output (PA23 to PA16). In other states, PAIORH is disabled.

A given pin on port A will be an output pin if the corresponding bit in PAIORH or PAIORL is set to 1, and an input pin if the bit is cleared to 0.

Bits 7 to 0 of PAIORH are, however, disabled in SH7144.

Bits 15 to 8 of PAIORH are reserved. These bits are always read as 0. The write value should always be 0.

The initial values of PAIORL and PAIORH are H'0000, respectively.

17.1.2 Port A Control Registers L2, L1, H (PACRL2, PACRL1, PACRH)

The port A control registers L2, L1, and H (PACRL2, PACRL1, and PACRH) are 16-bit readable/writable registers that are used to select the functions of the multiplexed pins on port A.

- Port A Control Registers L2, L1, and H (PACRL2, PACRL1, and PACRH) in SH7144

| Register | Bit | Bit Name | Initial Value | R/W | Description |
|----------|------------------------------|----------|-----------------|-----|--|
| PACRH | 15, 13 | — | All 0 | R | Reserved |
| PACRH | 11, 9 | — | All 0 | R | These bits are always read as 0. The write value should always be 0. |
| PACRH | 14, 12 | — | All 0 | R/W | |
| PACRH | 10, 8 | — | All 0 | R/W | |
| PACRH | 7 to 4, 2 to 0 | — | All 0 | R/W | |
| PACRH | 3 | — | 0 | R | |
| PACRL1 | 15, 13, 11, 9, 7, 5 | — | All 0 | R | |
| PACRL2 | 9, 7, 3, 1 | — | All 0 | R | |
| PACRL1 | 14 | PA15MD | 0* ¹ | R/W | PA15 Mode Selects the function of the PA15/CK pin. 0: PA15 I/O (port) 1: CK output (CPG) |
| PACRL1 | 12 | PA14MD | 0* ² | R/W | PA14 Mode Selects the function of the PA14/ \overline{RD} pin. 0: PA14 I/O (port) 1: \overline{RD} output (BSC) |
| PACRL1 | 10 | PA13MD | 0* ² | R/W | PA13 Mode Selects the function of the PA13/ \overline{WRH} pin. 0: PA13 I/O (port) 1: \overline{WRH} output (BSC) |

17. Pin Function Controller (PFC)

| Register | Bit | Bit Name | Initial Value | R/W | Description |
|----------|-----|----------|-----------------|-----|---|
| PACRL1 | 8 | PA12MD | 0* ² | R/W | PA12 Mode Selects the function of the PA12/ \overline{WRL} pin. 0: PA12 I/O (port) 1: \overline{WRL} output (BSC) |
| PACRL1 | 6 | PA11MD | 0* ² | R/W | PA11 Mode Selects the function of the PA11/ $\overline{CS1}$ pin. 0: PA11 I/O (port) 1: $\overline{CS1}$ output (BSC) |
| PACRL1 | 4 | PA10MD | 0* ² | R/W | PA10 Mode Selects the function of the PA10/ $\overline{CS0}$ pin. 0: PA10 I/O (port) 1: $\overline{CS0}$ output (BSC) |
| PACRL1 | 3 | PA9MD1 | 0 | R/W | PA9 Mode |
| PACRL1 | 2 | PA9MD0 | 0 | R/W | Select the function of the PA9/TCLKD/ $\overline{IRQ3}$ pin. 00: PA9 I/O (port) 01: TCLKD input (MTU) 10: $\overline{IRQ3}$ input (INTC) 11: Setting prohibited |
| PACRL1 | 1 | PA8MD1 | 0 | R/W | PA8 Mode |
| PACRL1 | 0 | PA8MD0 | 0 | R/W | Select the function of the PA8/TCLKC/ $\overline{IRQ2}$ pin. 00: PA8 I/O (port) 01: TCLKC input (MTU) 10: $\overline{IRQ2}$ input (INTC) 11: Setting prohibited |

| Register | Bit | Bit Name | Initial Value | R/W | Description |
|----------|-----|----------|---------------|-----|---|
| PACRL2 | 15 | PA7MD1 | 0 | R/W | PA7 Mode |
| PACRL2 | 14 | PA7MD0 | 0 | R/W | Select the function of the PA7/TCLKB/ $\overline{CS3}$ pin. 00: PA7 I/O (port) 01: TCLKB input (MTU) 10: $\overline{CS3}$ output (BSC) 11: Setting prohibited |
| PACRL2 | 13 | PA6MD1 | 0 | R/W | PA6 Mode |
| PACRL2 | 12 | PA6MD0 | 0 | R/W | Select the function of the PA6/TCLKA/ $\overline{CS2}$ pin. 00: PA6 I/O (port) 01: TCLKA input (MTU) 10: $\overline{CS2}$ output (BSC) 11: Setting prohibited |
| PACRL2 | 11 | PA5MD1 | 0 | R/W | PA5 Mode |
| PACRL2 | 10 | PA5MD0 | 0 | R/W | Select the function of the PA5/SCK1/ $\overline{DREQ1}$ / $\overline{IRQ1}$ pin. 00: PA5 I/O (port) 01: SCK1 I/O (SCI) 10: $\overline{DREQ1}$ input (DMAC) 11: $\overline{IRQ1}$ input (INTC) |
| PACRL2 | 8 | PA4MD | 0 | R/W | PA4 Mode Selects the function of the PA4/TXD1 pin. 0: PA4 I/O (port) 1: TXD1 output (SCI) |
| PACRL2 | 6 | PA3MD | 0 | R/W | PA3 Mode Selects the function of the PA3/RXD1 pin. 0: PA3 I/O (port) 1: RXD1 input (SCI) |

| Register | Bit | Bit Name | Initial Value | R/W | Description |
|----------|-----|----------|---------------|-----|---|
| PACRL2 | 5 | PA2MD1 | 0 | R/W | PA2 Mode |
| PACRL2 | 4 | PA2MD0 | 0 | R/W | Select the function of the PA2/SCK0/ $\overline{\text{DREQ0}}$ / $\overline{\text{IRQ0}}$ pin. 00: PA2 I/O (port) 01: SCK0 I/O (SCI) 10: $\overline{\text{DREQ0}}$ input (DMAC) 11: $\overline{\text{IRQ0}}$ input (INTC) |
| PACRL2 | 2 | PA1MD | 0 | R/W | PA1 Mode Selects the function of the PA1/TXD0 pin. 0: PA1 I/O (port) 1: TXD0 output (SCI) |
| PACRL2 | 0 | PA0MD | 0 | R/W | PA0 Mode Selects the function of the PA0/RXD0 pin. 0: PA0 I/O (port) 1: RXD0 input (SCI) |

- Notes:
1. The initial value is 1 in the on-chip ROM enabled/disabled external-expansion mode.
 2. The initial value is 1 in the on-chip ROM disabled external-expansion mode.

- Port A Control Registers L2, L1, and H (PACRL2, PACRL1 and PACRH) in the SH7145

| Register | Bit | Bit Name | Initial Value | R/W | Description |
|----------|------------------------------|----------|-----------------|-----|--|
| PACRH | 15 | — | 0 | R | Reserved |
| PACRH | 13 | — | 0 | R | These bits are always read as 0. The write value should always be 0. |
| PACRH | 11 | — | 0 | R | |
| PACRH | 9 | — | 0 | R | |
| PACRH | 3 | — | 0 | R | |
| PACRL1 | 15, 13, 11, 9, 7, 5 | — | All 0 | R | |
| PACRL2 | 9, 7, 3, 1 | — | All 0 | R | |
| PACRH | 14 | PA23MD | 0* ³ | R/W | PA23 Mode Selects the function of the PA23/ \overline{WRHH} pin. 0: PA23 I/O (port) 1: \overline{WRHH} output (BSC) |
| PACRH | 12 | PA22MD | 0* ³ | R/W | PA22 Mode Selects the function of the PA22/ \overline{WRHL} pin. 0: PA22 I/O (port) 1: \overline{WRHL} output (BSC) |
| PACRH | 10 | PA21MD | 0 | R/W | PA21 Mode Selects the function of the PA21/ $\overline{CS5}$ pin. 0: PA21 I/O (port) 1: $\overline{CS5}$ output (BSC)* ⁴ |
| PACRH | 8 | PA20MD | 0 | R/W | PA20 Mode Selects the function of the PA20/ $\overline{CS4}$ pin. 0: PA20 I/O (port) 1: $\overline{CS4}$ output (BSC)* ⁴ |
| PACRH | 7 | PA19MD1 | 0 | R/W | PA19 Mode |
| PACRH | 6 | PA19MD0 | 0 | R/W | Select the function of the PA19/ \overline{BACK} /DRAK1 pin. 00: PA19 I/O (port) 01: \overline{BACK} output (BSC) 10: DRAK1 output (DMAC) 11: Setting prohibited |

17. Pin Function Controller (PFC)

| Register | Bit | Bit Name | Initial Value | R/W | Description |
|----------|-----|----------|-----------------|-----|---|
| PACRH | 5 | PA18MD1 | 0 | R/W | PA18 Mode |
| PACRH | 4 | PA18MD0 | 0 | R/W | Select the function of the PA18/ $\overline{\text{BREQ}}$ /DRAK0 pin. 00: PA18 I/O (port) 01: $\overline{\text{BREQ}}$ input (BSC) 10: DRAK0 output (DMAC) 11: Setting prohibited |
| PACRH | 2 | PA17MD | 0 | R/W | PA17 Mode Selects the function of the PA17/ $\overline{\text{WAIT}}$ pin. 0: PA17 I/O (port) 1: $\overline{\text{WAIT}}$ input (BSC) |
| PACRH | 1 | PA16MD1 | 0 | R/W | PA16 Mode |
| PACRH | 0 | PA16MD0 | 0 | R/W | Select the function of the PA16/ $\overline{\text{AUDSYNC}}$ pin. 00: PA16 I/O (port) 01: Setting prohibited 10: Setting prohibited 11: $\overline{\text{AUDSYNC}}$ I/O (AUD)* ¹ |
| PACRL1 | 14 | PA15MD | 0* ² | R/W | PA15 Mode Selects the function of the PA15/CK pin. 0: PA15 I/O (port) 1: CK output (CPG) |
| PACRL1 | 12 | PA14MD | 0* ³ | R/W | PA14 Mode Selects the function of the PA14/ $\overline{\text{RD}}$ pin. 0: PA14 I/O (port) 1: $\overline{\text{RD}}$ output (BSC) |
| PACRL1 | 10 | PA13MD | 0* ³ | R/W | PA13 Mode Selects the function of the PA13/ $\overline{\text{WRH}}$ pin. 0: PA13 I/O (port) 1: $\overline{\text{WRH}}$ output (BSC) |
| PACRL1 | 8 | PA12MD | 0* ³ | R/W | PA12 Mode Selects the function of the PA12/ $\overline{\text{WRL}}$ pin. 0: PA12 I/O (port) 1: $\overline{\text{WRL}}$ output (BSC) |

| Register | Bit | Bit Name | Initial Value | R/W | Description |
|----------|-----|----------|-----------------|-----|---|
| PACRL1 | 6 | PA11MD | 0* ³ | R/W | PA11 Mode Selects the function of the PA11/ $\overline{CS1}$ pin. 0: PA11 I/O (port) 1: $\overline{CS1}$ output (BSC) |
| PACRL1 | 4 | PA10MD | 0* ³ | R/W | PA10 Mode Selects the function of the PA10/ $\overline{CS0}$ pin. 0: PA10 I/O (port) 1: $\overline{CS0}$ output (BSC) |
| PACRL1 | 3 | PA9MD1 | 0 | R/W | PA9 Mode |
| PACRL1 | 2 | PA9MD0 | 0 | R/W | Select the function of the PA9/TCLKD/ $\overline{IRQ3}$ pin. 00: PA9 I/O (port) 01: TCLKD input (MTU) 10: $\overline{IRQ3}$ input (INTC) 11: Setting prohibited |
| PACRL1 | 1 | PA8MD1 | 0 | R/W | PA8 Mode |
| PACRL1 | 0 | PA8MD0 | 0 | R/W | Select the function of the PA8/TCLKC/ $\overline{IRQ2}$ pin. 00: PA8 I/O (port) 01: TCLKC input (MTU) 10: $\overline{IRQ2}$ input (INTC) 11: Setting prohibited |
| PACRL2 | 15 | PA7MD1 | 0 | R/W | PA7 Mode |
| PACRL2 | 14 | PA7MD0 | 0 | R/W | Select the function of the PA7/TCLKB/ $\overline{CS3}$ pin. 00: PA7 I/O (port) 01: TCLKB input (MTU) 10: $\overline{CS3}$ output (BSC) 11: Setting prohibited |
| PACRL2 | 13 | PA6MD1 | 0 | R/W | PA6 Mode |
| PACRL2 | 12 | PA6MD0 | 0 | R/W | Select the function of the PA6/TCLKA/ $\overline{CS2}$ pin. 00: PA6 I/O (port) 01: TCLKA input (MTU) 10: $\overline{CS2}$ output (BSC) 11: Setting prohibited |

17. Pin Function Controller (PFC)

| Register | Bit | Bit Name | Initial Value | R/W | Description |
|----------|-----|----------|---------------|-----|---|
| PACRL2 | 11 | PA5MD1 | 0 | R/W | PA5 Mode |
| PACRL2 | 10 | PA5MD0 | 0 | R/W | Select the function of the PA5/SCK1/ $\overline{\text{DREQ1}}$ / $\overline{\text{IRQ1}}$ pin. 00: PA5 I/O (port) 01: SCK1 I/O (SCI) 10: $\overline{\text{DREQ1}}$ input (DMAC) 11: $\overline{\text{IRQ1}}$ input (INTC) |
| PACRL2 | 8 | PA4MD | 0 | R/W | PA4 Mode Selects the function of the PA4/TXD1 pin. 0: PA4 I/O (port) 1: TXD1 output (SCI) |
| PACRL2 | 6 | PA3MD | 0 | R/W | PA3 Mode Selects the function of the PA3/RXD1 pin. 0: PA3 I/O (port) 1: RXD1 input (SCI) |
| PACRL2 | 5 | PA2MD1 | 0 | R/W | PA2 Mode |
| PACRL2 | 4 | PA2MD0 | 0 | R/W | Select the function of the PA2/SCK0/ $\overline{\text{DREQ0}}$ / $\overline{\text{IRQ0}}$ pin. 00: PA2 I/O (port) 01: SCK0 I/O (SCI) 10: $\overline{\text{DREQ0}}$ input (DMAC) 11: $\overline{\text{IRQ0}}$ input (INTC) |
| PACRL2 | 2 | PA1MD | 0 | R/W | PA1 Mode Selects the function of the PA1/TXD0 pin. 0: PA1 I/O (port) 1: TXD0 output (SCI) |
| PACRL2 | 0 | PA0MD | 0 | R/W | PA0 Mode Selects the function of the PA0/RXD0 pin. 0: PA0 I/O (port) 1: RXD0 input (SCI) |

- Notes:
1. F-ZTAT version only. Setting prohibited for the masked ROM version and ROM less version.
 2. The initial value is 1 in the on-chip ROM enabled/disabled external-expansion mode.
 3. The initial value is 1 in the on-chip ROM disabled external-expansion mode.
 4. Masked ROM version and ROM less version only. Setting prohibited for the F-ZTAT version and emulator.

17.1.3 Port B I/O Register (PBIOR)

The port B I/O register (PBIOR) is a 16-bit readable/writable register that is used to set the pins on port B as inputs or outputs. Bits PB9IOR to PB0IOR correspond to pins PB9 to PB0 (names of multiplexed pins are here given as port names and pin numbers alone). PBIOR is enabled when port B pins are functioning as general-purpose inputs/outputs (PB9 to PB0). In other states, PBIOR is disabled.

A given pin on port B will be an output pin if the corresponding bit in PBIOR is set to 1, and an input pin if the bit is cleared to 0.

Bits 15 to 10 are reserved. These bits are always read as 0. The write value should always be 0.

The initial value of PBIOR is H'0000.

17.1.4 Port B Control Registers 1, 2 (PBCR1, PBCR2)

The port B control registers 1 and 2 (PBCR1 and PBCR2) are 16-bit readable/writable registers that are used to select the multiplexed pin function of the pins on port B.

- Port B Control Registers 1 and 2 (PBCR1 and PBCR2)

| Register | Bit | Bit Name | Initial Value | R/W | Description |
|----------|--------|----------|---------------|-----|---|
| PBCR1 | 15, 14 | — | All 0 | R | Reserved |
| PBCR1 | 13, 12 | — | All 0 | R/W | These bits are always read as 0. The write value should always be 0. |
| PBCR1 | 9 to 4 | — | All 0 | R | |
| PBCR2 | 3, 1 | — | All 0 | R | |
| PBCR1 | 3 | PB9MD1 | 0 | R | PB9 Mode |
| PBCR1 | 2 | PB9MD0 | 0 | R | Select the function of the PB9/ $\overline{\text{IRQ7}}$ /A21/ $\overline{\text{ADTRG}}$ pin. 00: PB9 I/O (port) 01: $\overline{\text{IRQ7}}$ input (INTC) 10: A21 output (BSC) 11: $\overline{\text{ADTRG}}$ input (A/D) |
| PBCR1 | 1 | PB8MD1 | 0 | R/W | PB8 Mode |
| PBCR1 | 0 | PB8MD0 | 0 | R/W | Select the function of the PB8/ $\overline{\text{IRQ6}}$ /A20/ $\overline{\text{WAIT}}$ pin. 00: PB8 I/O (port) 01: $\overline{\text{IRQ6}}$ input (INTC) 10: A20 output (BSC) 11: $\overline{\text{WAIT}}$ input (BSC) |
| PBCR2 | 15 | PB7MD1 | 0 | R/W | PB7 Mode |
| PBCR2 | 14 | PB7MD0 | 0 | R/W | Select the function of the PB7/ $\overline{\text{IRQ5}}$ /A19/ $\overline{\text{BREQ}}$ pin. 00: PB7 I/O (port) 01: $\overline{\text{IRQ5}}$ input (INTC) 10: A19 output (BSC) 11: $\overline{\text{BREQ}}$ input (BSC) |

| Register | Bit | Bit Name | Initial Value | R/W | Description |
|----------|-----|----------|---------------|-----|--|
| PBCR2 | 13 | PB6MD1 | 0 | R/W | PB6 Mode |
| PBCR2 | 12 | PB6MD0 | 0 | R/W | Select the function of the PB6/ $\overline{\text{IRQ4}}$ /A18/ $\overline{\text{BACK}}$ pin. 00: PB6 I/O (port) 01: $\overline{\text{IRQ4}}$ input (INTC) 10: A18 output (BSC) 11: $\overline{\text{BACK}}$ output (BSC) |
| PBCR2 | 11 | PB5MD1 | 0 | R/W | PB5 Mode |
| PBCR2 | 10 | PB5MD0 | 0 | R/W | Select the function of the PB5/ $\overline{\text{IRQ3}}$ / $\overline{\text{POE3}}$ / $\overline{\text{CS7}}$ pin. 00: PB5 I/O (port) 01: $\overline{\text{IRQ3}}$ input (INTC) 10: $\overline{\text{POE3}}$ input (port) 11: $\overline{\text{CS7}}$ output (BSC)* ² |
| PBCR2 | 9 | PB4MD1 | 0 | R/W | PB4 Mode |
| PBCR2 | 8 | PB4MD0 | 0 | R/W | Select the function of the PB4/ $\overline{\text{IRQ2}}$ / $\overline{\text{POE2}}$ / $\overline{\text{CS6}}$ pin. 00: PB4 I/O (port) 01: $\overline{\text{IRQ2}}$ input (INTC) 10: $\overline{\text{POE2}}$ input (port) 11: $\overline{\text{CS6}}$ output (BSC)* ² |
| PBCR1 | 11 | PB3MD2 | 0 | R/W | PB3 Mode |
| PBCR2 | 7 | PB3MD1 | 0 | R/W | Select the function of the PB3/ $\overline{\text{IRQ1}}$ / $\overline{\text{POE1}}$ /SDA0 pin. |
| PBCR2 | 6 | PB3MD0 | 0 | R/W | 000: PB3 I/O (port) 001: $\overline{\text{IRQ1}}$ input (INTC) 010: $\overline{\text{POE1}}$ input (port) 011: Setting prohibited 100: SDA0 I/O (IIC) 101: Setting prohibited 110: Setting prohibited 111: Setting prohibited |

| Register | Bit | Bit Name | Initial Value | R/W | Description |
|----------|-----|----------|-----------------|-----|--|
| PBCR1 | 10 | PB2MD2 | 0 | R/W | PB2 Mode |
| PBCR2 | 5 | PB2MD1 | 0 | R/W | Select the function of the PB2/ $\overline{\text{IRQ0}}$ / $\overline{\text{POE0}}$ / $\overline{\text{SCL0}}$ pin. |
| PBCR2 | 4 | PB2MD0 | 0 | R/W | 000: PB2 I/O (port) 001: $\overline{\text{IRQ0}}$ input (INTC) 010: $\overline{\text{POE0}}$ input (port) 011: Setting prohibited 100: $\overline{\text{SCL0}}$ I/O (IIC) 101: Setting prohibited 110: Setting prohibited 111: Setting prohibited |
| PBCR2 | 2 | PB1MD | 0* ¹ | R/W | PB1 Mode Selects the function of the PB1/A17 pin. 0: PB1 I/O (port) 1: A17 output (BSC) |
| PBCR2 | 0 | PB0MD | 0* ¹ | R/W | PB0 Mode Selects the function of the PB0/A16 pin. 0: PB0 I/O (port) 1: A16 output (BSC) |

- Notes: 1. The initial value is 1 in the on-chip ROM disabled external-expansion mode.
2. Masked ROM version and ROM less version only. Setting prohibited for the F-ZTAT version and emulator.

17.1.5 Port C I/O Register (PCIOR)

PCIOR is a 16-bit readable/writable register that is used to set the pins on port C as inputs or outputs. Bits PC15IOR to PC0IOR correspond to pins PC15 to PC0 (names of multiplexed pins are here given as port names and pin numbers alone). PCIOR is enabled when the port C pins are functioning as general-purpose inputs/outputs (PC15 to PC0). In other states, PCIOR is disabled.

A given pin on port C will be an output pin if the corresponding bit in PCIOR is set to 1, and an input pin if the bit is cleared to 0.

The initial value of PCIOR is H'0000.

17.1.6 Port C Control Register (PCCR)

PCCR is a 16-bit readable/writable register that is used to select the multiplexed pin function of the pins on port C.

- Port C Control Register (PCCR)

| Register | Bit | Bit Name | Initial Value | R/W | Description |
|----------|-----|----------|---------------|-----|---|
| PCCR | 15 | PC15MD | 0* | R/W | PC15 Mode Selects the function of the PC15/A15 pin. 0: PC15 I/O (port) 1: A15 output (BSC) |
| PCCR | 14 | PC14MD | 0* | R/W | PC14 Mode Selects the function of the PC14/A14 pin. 0: PC14 I/O (port) 1: A14 output (BSC) |
| PCCR | 13 | PC13MD | 0* | R/W | PC13 Mode Selects the function of the PC13/A13 pin. 0: PC13 I/O (port) 1: A13 output (BSC) |
| PCCR | 12 | PC12MD | 0* | R/W | PC12 Mode Selects the function of the PC12/A12 pin. 0: PC12 I/O (port) 1: A12 output (BSC) |

17. Pin Function Controller (PFC)

| Register | Bit | Bit Name | Initial Value | R/W | Description |
|----------|-----|----------|---------------|-----|---|
| PCCR | 11 | PC11MD | 0* | R/W | PC11 Mode Selects the function of the PC11/A11 pin. 0: PC11 I/O (port) 1: A11 output (BSC) |
| PCCR | 10 | PC10MD | 0* | R/W | PC10 Mode Selects the function of the PC10/A10 pin. 0: PC10 I/O (port) 1: A10 output (BSC) |
| PCCR | 9 | PC9MD | 0* | R/W | PC9 Mode Selects the function of the PC9/A9 pin. 0: PC9 I/O (port) 1: A9 output (BSC) |
| PCCR | 8 | PC8MD | 0* | R/W | PC8 Mode Selects the function of the PC8/A8 pin. 0: PC8 I/O (port) 1: A8 output (BSC) |
| PCCR | 7 | PC7MD | 0* | R/W | PC7 Mode Selects the function of the PC7/A7 pin. 0: PC7 I/O (port) 1: A7 output (BSC) |
| PCCR | 6 | PC6MD | 0* | R/W | PC6 Mode Selects the function of the PC6/A6 pin. 0: PC6 I/O (port) 1: A6 output (BSC) |
| PCCR | 5 | PC5MD | 0* | R/W | PC5 Mode Selects the function of the PC5/A5 pin. 0: PC5 I/O (port) 1: A5 output (BSC) |
| PCCR | 4 | PC4MD | 0* | R/W | PC4 Mode Selects the function of the PC4/A4 pin. 0: PC4 I/O (port) 1: A4 output (BSC) |

| Register | Bit | Bit Name | Initial Value | R/W | Description |
|----------|-----|----------|---------------|-----|--|
| PCCR | 3 | PC3MD | 0* | R/W | PC3 Mode Selects the function of the PC3/A3 pin. 0: PC3 I/O (port) 1: A3 output (BSC) |
| PCCR | 2 | PC2MD | 0* | R/W | PC2 Mode Selects the function of the PC2/A2 pin. 0: PC2 I/O (port) 1: A2 output (BSC) |
| PCCR | 1 | PC1MD | 0* | R/W | PC1 Mode Selects the function of the PC1/A1 pin. 0: PC1 I/O (port) 1: A1 output (BSC) |
| PCCR | 0 | PC0MD | 0* | R/W | PC0 Mode Selects the function of the PC0/A0 pin. 0: PC0 I/O (port) 1: A0 output (BSC) |

Note: * The initial value is 1 in the on-chip ROM disabled external-expansion mode.

17.1.7 Port D I/O Registers L, H (PDIORL, PDIORH)

The port D I/O registers L and H (PDIORL and PDIORH) are 16-bit readable/writable registers that are used to set the pins on port D as inputs or outputs. Bits PD31IOR to PD0IOR correspond to pins PD31 to PD0 (names of multiplexed pins are here given as port names and pin numbers alone). PDIORL is enabled when the port D pins are functioning as general-purpose inputs/outputs (PD15 to PD0). In other states, PDIORL is disabled. PDIORH is enabled when the port D pins are functioning as general-purpose inputs/outputs (PD31 to PD16). In other states, PDIORH is disabled.

A given pin on port D will be an output pin if the corresponding bit in PDIORL or PDIORH is set to 1, and an input pin if the bit is cleared to 0.

Note that bits 15 to 0 in PDIORH are disabled in the SH7144.

The initial value of PDIOR is H'0000.

17.1.8 Port D Control Registers L1, L2, H1, H2 (PDCRL1, PDCRL2, PDCRH1, PDCRH2)

The port D control registers L1, L2, H1, and H2 (PDCRL1, PDCRL2, PDCRH1, and PDCRH2) are 16-bit readable/writable registers that are used to select the multiplexed pin function of the pins on port D.

- Port D Control Registers L1, L2, H1, and H2 (PDCRL1, PDCRL2, PDCRH1, and PDCRH2) in SH7144

| Register | Bit | Bit Name | Initial Value | R/W | Description |
|----------|---------|----------|-----------------|-----|---|
| PDCRH1 | 15 to 0 | — | All 0 | R/W | Reserved |
| PDCRH2 | 15 to 0 | — | All 0 | R/W | These bits are always read as 0. The write value should always be 0. |
| PDCRL2 | 7 to 0 | — | All 0 | R | |
| PDCRL2 | 15 | PD15MD1 | 0 | R/W | PD15 Mode |
| PDCRL1 | 15 | PD15MD0 | 0* ² | R/W | Select the function of the PD15/D15/AUDSYNC pin. 00: PD15 I/O (port) 01: D15 I/O (BSC) 10: $\overline{\text{AUDSYNC}}$ I/O (AUD)* ¹ 11: Setting prohibited |
| PDCRL2 | 14 | PD14MD1 | 0 | R/W | PD14 Mode |
| PDCRL1 | 14 | PD14MD0 | 0* ² | R/W | Select the function of the PD14/D14/AUDCK pin. 00: PD14 I/O (port) 01: D14 I/O (BSC) 10: AUDCK I/O (AUD)* ¹ 11: Setting prohibited |
| PDCRL2 | 13 | PD13MD1 | 0 | R/W | PD13 Mode |
| PDCRL1 | 13 | PD13MD0 | 0* ² | R/W | Select the function of the PD13/D13/AUDMD pin. 00: PD13 I/O (port) 01: D13 I/O (BSC) 10: AUDMD input (AUD)* ¹ 11: Setting prohibited |

| Register | Bit | Bit Name | Initial Value | R/W | Description |
|----------|-----|----------|-----------------|-----|--|
| PDCRL2 | 12 | PD12MD1 | 0 | R/W | PD12 Mode |
| PDCRL1 | 12 | PD12MD0 | 0* ² | R/W | Select the function of the PD12/D12/ $\overline{\text{AUDRST}}$ pin. 00: PD12 I/O (port) 01: D12 I/O (BSC) 10: $\overline{\text{AUDRST}}$ input (AUD)* ¹ 11: Setting prohibited |
| PDCRL2 | 11 | PD11MD1 | 0 | R/W | PD11 Mode |
| PDCRL1 | 11 | PD11MD0 | 0* ² | R/W | Select the function of the PD11/D11/AUDATA3 pin. 00: PD11 I/O (port) 01: D11 I/O (BSC) 10: AUDATA3 I/O (AUD)* ¹ 11: Setting prohibited |
| PDCRL2 | 10 | PD10MD1 | 0 | R/W | PD10 Mode |
| PDCRL1 | 10 | PD10MD0 | 0* ² | R/W | Select the function of the PD10/D10/AUDATA2 pin. 00: PD10 I/O (port) 01: D10 I/O (BSC) 10: AUDATA2 I/O (AUD)* ¹ 11: Setting prohibited |
| PDCRL2 | 9 | PD9MD1 | 0 | R/W | PD9 Mode |
| PDCRL1 | 9 | PD9MD0 | 0* ² | R/W | Select the function of the PD9/D9/AUDATA1 pin. 00: PD9 I/O (port) 01: D9 I/O (BSC) 10: AUDATA1 I/O (AUD)* ¹ 11: Setting prohibited |
| PDCRL2 | 8 | PD8MD1 | 0 | R/W | PD8 Mode |
| PDCRL1 | 8 | PD8MD0 | 0* ² | R/W | Select the function of the PD8/D8/AUDATA0 pin. 00: PD8 I/O (port) 01: D8 I/O (BSC) 10: AUDATA0 I/O (AUD)* ¹ 11: Setting prohibited |

17. Pin Function Controller (PFC)

| Register | Bit | Bit Name | Initial Value | R/W | Description |
|----------|-----|----------|-----------------|-----|---|
| PDCRL1 | 7 | PD7MD | 0* ³ | R/W | PD7 Mode Selects the function of the PD7/D7 pin. 0: PD7 I/O (port) 1: D7 I/O (BSC) |
| PDCRL1 | 6 | PD6MD | 0* ³ | R/W | PD6 Mode Selects the function of the PD6/D6 pin. 0: PD6 I/O (port) 1: D6 I/O (BSC) |
| PDCRL1 | 5 | PD5MD | 0* ³ | R/W | PD5 Mode Selects the function of the PD5/D5 pin. 0: PD5 I/O (port) 1: D5 I/O (BSC) |
| PDCRL1 | 4 | PD4MD | 0* ³ | R/W | PD4 Mode Selects the function of the PD4/D4 pin. 0: PD4 I/O (port) 1: D4 I/O (BSC) |
| PDCRL1 | 3 | PD3MD | 0* ³ | R/W | PD3 Mode Selects the function of the PD3/D3 pin. 0: PD3 I/O (port) 1: D3 I/O (BSC) |
| PDCRL1 | 2 | PD2MD | 0* ³ | R/W | PD2 Mode Selects the function of the PD2/D2 pin. 0: PD2 I/O (port) 1: D2 I/O (BSC) |
| PDCRL1 | 1 | PD1MD | 0* ³ | R/W | PD1 Mode Selects the function of the PD1/D1 pin. 0: PD1 I/O (port) 1: D1 I/O (BSC) |
| PDCRL1 | 0 | PD0MD | 0* ³ | R/W | PD0 Mode Selects the function of the PD0/D0 pin. 0: PD0 I/O (port) 1: D0 I/O (BSC) |

Notes: 1. F-ZTAT version only. Setting prohibited for the masked ROM version and ROM less version.

2. The initial value is 1 in the on-chip ROM disabled 16-bit external-expansion mode.

3. The initial value is 1 in the on-chip ROM disabled external-expansion mode.

- Port D Control Registers L1, L2, H1, and H2 (PDCRL1, PDCRL2, PDCRH1, and PDCRH2) in SH7145

| Register | Bit | Bit Name | Initial Value | R/W | Description |
|----------|--------|----------|-----------------|-----|--|
| PDCRL2 | 7 to 0 | — | All 0 | R | Reserved These bits are always read as 0. The write value should always be 0. |
| PDCRH1 | 15 | PD31MD1 | 0 | R/W | PD31 Mode |
| PDCRH1 | 14 | PD31MD0 | 0* ² | R/W | Select the function of the PD31/D31/ $\overline{\text{ADTRG}}$ pin. 00: PD31 I/O (port) 01: D31 I/O (BSC) 10: $\overline{\text{ADTRG}}$ input (A/D) 11: Setting prohibited |
| PDCRH1 | 13 | PD30MD1 | 0 | R/W | PD30 Mode |
| PDCRH1 | 12 | PD30MD0 | 0* ² | R/W | Select the function of the PD30/D30/ $\overline{\text{IRQOUT}}$ pin. 00: PD30 I/O (port) 01: D30 I/O (BSC) 10: $\overline{\text{IRQOUT}}$ output (INTC) 11: Setting prohibited |
| PDCRH1 | 11 | PD29MD1 | 0 | R/W | PD29 Mode |
| PDCRH1 | 10 | PD29MD0 | 0* ² | R/W | Select the function of the PD29/D29/ $\overline{\text{CS3}}$ pin. 00: PD29 I/O (port) 01: D29 I/O (BSC) 10: $\overline{\text{CS3}}$ output (BSC) 11: Setting prohibited |
| PDCRH1 | 9 | PD28MD1 | 0 | R/W | PD28 Mode |
| PDCRH1 | 8 | PD28MD0 | 0* ² | R/W | Select the function of the PD28/D28/ $\overline{\text{CS2}}$ pin. 00: PD28 I/O (port) 01: D28 I/O (BSC) 10: $\overline{\text{CS2}}$ output (BSC) 11: Setting prohibited |

17. Pin Function Controller (PFC)

| Register | Bit | Bit Name | Initial Value | R/W | Description |
|----------|-----|----------|-----------------|-----|---|
| PDCRH1 | 7 | PD27MD1 | 0 | R/W | PD27 Mode |
| PDCRH1 | 6 | PD27MD0 | 0* ² | R/W | Select the function of the PD27/D27/DACK1 pin. 00: PD27 I/O (port) 01: D27 I/O (BSC) 10: DACK1 output (DMAC) 11: Setting prohibited |
| PDCRH1 | 5 | PD26MD1 | 0 | R/W | PD26 Mode |
| PDCRH1 | 4 | PD26MD0 | 0* ² | R/W | Select the function of the PD26/D26/DACK0 pin. 00: PD26 I/O (port) 01: D26 I/O (BSC) 10: DACK0 output (DMAC) 11: Setting prohibited |
| PDCRH1 | 3 | PD25MD1 | 0 | R/W | PD25 Mode |
| PDCRH1 | 2 | PD25MD0 | 0* ² | R/W | Select the function of the PD25/D25/ $\overline{\text{DREQ1}}$ pin. 00: PD25 I/O (port) 01: D25 I/O (BSC) 10: $\overline{\text{DREQ1}}$ input (DMAC) 11: Setting prohibited |
| PDCRH1 | 1 | PD24MD1 | 0 | R/W | PD24 Mode |
| PDCRH1 | 0 | PD24MD0 | 0* ² | R/W | Select the function of the PD24/D24/ $\overline{\text{DREQ0}}$ pin. 00: PD24 I/O (port) 01: D24 I/O (BSC) 10: $\overline{\text{DREQ0}}$ input (DMAC) 11: Setting prohibited |
| PDCRH2 | 15 | PD23MD1 | 0 | R/W | PD23 Mode |
| PDCRH2 | 14 | PD23MD0 | 0* ² | R/W | Select the function of the PD23/D23/ $\overline{\text{IRQ7}}$ /AUDSYNC pin. 00: PD23 I/O (port) 01: D23 I/O (BSC) 10: $\overline{\text{IRQ7}}$ input (INTC) 11: AUDSYNC I/O (AUD)* ¹ |

| Register | Bit | Bit Name | Initial Value | R/W | Description |
|----------|-----|----------|-----------------|-----|---|
| PDCRH2 | 13 | PD22MD1 | 0 | R/W | PD22 Mode |
| PDCRH2 | 12 | PD22MD0 | 0* ² | R/W | Select the function of the PD22/D22/ $\overline{\text{IRQ6}}$ /AUDCK pin. 00: PD22 I/O (port) 01: D22 I/O (BSC) 10: $\overline{\text{IRQ6}}$ input (INTC) 11: AUDCK I/O (AUD)* ¹ |
| PDCRH2 | 11 | PD21MD1 | 0 | R/W | PD21 Mode |
| PDCRH2 | 10 | PD21MD0 | 0* ² | R/W | Select the function of the PD21/D21/ $\overline{\text{IRQ5}}$ /AUDMD pin. 00: PD21 I/O (port) 01: D21 I/O (BSC) 10: $\overline{\text{IRQ5}}$ input (INTC) 11: AUDMD input (AUD)* ¹ |
| PDCRH2 | 9 | PD20MD1 | 0 | R/W | PD20 Mode |
| PDCRH2 | 8 | PD20MD0 | 0* ² | R/W | Select the function of the PD20/D20/ $\overline{\text{IRQ4}}$ /AUDRST pin. 00: PD20 I/O (port) 01: D20 I/O (BSC) 10: $\overline{\text{IRQ4}}$ input (INTC) 11: $\overline{\text{AUDRST}}$ input (AUD)* ¹ |
| PDCRH2 | 7 | PD19MD1 | 0 | R/W | PD19 Mode |
| PDCRH2 | 6 | PD19MD0 | 0* ² | R/W | Select the function of the PD19/D19/ $\overline{\text{IRQ3}}$ /AUDATA3 pin. 00: PD19 I/O (port) 01: D19 I/O (BSC) 10: $\overline{\text{IRQ3}}$ input (INTC) 11: AUDATA3 I/O (AUD)* ¹ |
| PDCRH2 | 5 | PD18MD1 | 0 | R/W | PD18 Mode |
| PDCRH2 | 4 | PD18MD0 | 0* ² | R/W | Select the function of the PD18/D18/ $\overline{\text{IRQ2}}$ /AUDATA2 pin. 00: PD18 I/O (port) 01: D18 I/O (BSC) 10: $\overline{\text{IRQ2}}$ input (INTC) 11: AUDATA2 I/O (AUD)* ¹ |

17. Pin Function Controller (PFC)

| Register | Bit | Bit Name | Initial Value | R/W | Description |
|----------|-----|----------|-----------------|-----|---|
| PDCRH2 | 3 | PD17MD1 | 0 | R/W | PD17 Mode |
| PDCRH2 | 2 | PD17MD0 | 0* ² | R/W | Select the function of the PD17/D17/ $\overline{IRQ1}$ /AUDATA1 pin. 00: PD17 I/O (port) 01: D17 I/O (BSC) 10: $\overline{IRQ1}$ input (INTC) 11: AUDATA1 I/O (AUD)* ¹ |
| PDCRH2 | 1 | PD16MD1 | 0 | R/W | PD16 Mode |
| PDCRH2 | 0 | PD16MD0 | 0* ² | R/W | Select the function of the PD16/D16/ $\overline{IRQ0}$ /AUDATA0 pin. 00: PD16 I/O (port) 01: D16 I/O (BSC) 10: $\overline{IRQ0}$ input (INTC) 11: AUDATA0 I/O (AUD)* ¹ |
| PDCRL2 | 15 | PD15MD1 | 0 | R/W | PD15 Mode |
| PDCRL1 | 15 | PD15MD0 | 0* ³ | R/W | Select the function of the PD15/D15 pin. 00: PD15 I/O (port) 01: D15 I/O (BSC) 10: Setting prohibited 11: Setting prohibited |
| PDCRL2 | 14 | PD14MD1 | 0 | R/W | PD14 Mode |
| PDCRL1 | 14 | PD14MD0 | 0* ³ | R/W | Select the function of the PD14/D14 pin. 00: PD14 I/O (port) 01: D14 I/O (BSC) 10: Setting prohibited 11: Setting prohibited |
| PDCRL2 | 13 | PD13MD1 | 0 | R/W | PD13 Mode |
| PDCRL1 | 13 | PD13MD0 | 0* ³ | R/W | Select the function of the PD13/D13 pin. 00: PD13 I/O (port) 01: D13 I/O (BSC) 10: Setting prohibited 11: Setting prohibited |

| Register | Bit | Bit Name | Initial Value | R/W | Description |
|----------|-----|----------|-----------------|-----|--|
| PDCRL2 | 12 | PD12MD1 | 0 | R/W | PD12 Mode |
| PDCRL1 | 12 | PD12MD0 | 0* ³ | R/W | Select the function of the PD12/D12 pin. 00: PD12 I/O (port) 01: D12 I/O (BSC) 10: Setting prohibited 11: Setting prohibited |
| PDCRL2 | 11 | PD11MD1 | 0 | R/W | PD11 Mode |
| PDCRL1 | 11 | PD11MD0 | 0* ³ | R/W | Select the function of the PD11/D11 pin. 00: PD11 I/O (port) 01: D11 I/O (BSC) 10: Setting prohibited 11: Setting prohibited |
| PDCRL2 | 10 | PD10MD1 | 0 | R/W | PD10 Mode |
| PDCRL1 | 10 | PD10MD0 | 0* ³ | R/W | Select the function of the PD10/D10 pin. 00: PD10 I/O (port) 01: D10 I/O (BSC) 10: Setting prohibited 11: Setting prohibited |
| PDCRL2 | 9 | PD9MD1 | 0 | R/W | PD9 Mode |
| PDCRL1 | 9 | PD9MD0 | 0* ³ | R/W | Select the function of the PD9/D9 pin. 00: PD9 I/O (port) 01: D9 I/O (BSC) 10: Setting prohibited 11: Setting prohibited |
| PDCRL2 | 8 | PD8MD1 | 0 | R/W | PD8 Mode |
| PDCRL1 | 8 | PD8MD0 | 0* ³ | R/W | Select the function of the PD8/D8 pin. 00: PD8 I/O (port) 01: D8 I/O (BSC) 10: Setting prohibited 11: Setting prohibited |

17. Pin Function Controller (PFC)

| Register | Bit | Bit Name | Initial Value | R/W | Description |
|----------|-----|----------|-----------------|-----|---|
| PDCRL1 | 7 | PD7MD | 0* ³ | R/W | PD7 Mode Selects the function of the PD7/D7 pin. 0: PD7 I/O (port) 1: D7 I/O (BSC) |
| PDCRL1 | 6 | PD6MD | 0* ³ | R/W | PD6 Mode Selects the function of the PD6/D6 pin. 0: PD6 I/O (port) 1: D6 I/O (BSC) |
| PDCRL1 | 5 | PD5MD | 0* ³ | R/W | PD5 Mode Selects the function of the PD5/D5 pin. 0: PD5 I/O (port) 1: D5 I/O (BSC) |
| PDCRL1 | 4 | PD4MD | 0* ³ | R/W | PD4 Mode Selects the function of the PD4/D4 pin. 0: PD4 I/O (port) 1: D4 I/O (BSC) |
| PDCRL1 | 3 | PD3MD | 0* ³ | R/W | PD3 Mode Selects the function of the PD3/D3 pin. 0: PD3 I/O (port) 1: D3 I/O (BSC) |
| PDCRL1 | 2 | PD2MD | 0* ³ | R/W | PD2 Mode Selects the function of the PD2/D2 pin. 0: PD2 I/O (port) 1: D2 I/O (BSC) |
| PDCRL1 | 1 | PD1MD | 0* ³ | R/W | PD1 Mode Selects the function of the PD1/D1 pin. 0: PD1 I/O (port) 1: D1 I/O (BSC) |
| PDCRL1 | 0 | PD0MD | 0* ³ | R/W | PD0 Mode Selects the function of the PD0/D0 pin. 0: PD0 I/O (port) 1: D0 I/O (BSC) |

Notes: 1. F-ZTAT version only. Setting prohibited for the masked ROM version and ROM less version.

2. The initial value is 1 in the on-chip ROM disabled 32-bit external-expansion mode.

3. The initial value is 1 in the on-chip ROM disabled external-expansion mode.

17.1.9 Port E I/O Register L (PEIORL)

The port E I/O register L (PEIORL) is a 16-bit readable/writable register that is used to set the pins on port E as inputs or outputs. Bits PE15IOR to PE0IOR correspond to pins PE15 to PE0 (names of multiplexed pins are here given as port names and pin numbers alone). PEIORL is enabled when the port E pins are functioning as general-purpose inputs/outputs (PE15 to PD0), TIOC pins are functioning as inputs/outputs of MTU, and SCK2 and SCK3 pins are functioning as inputs/outputs of SCI. In other states, PEIORL is disabled.

A given pin on port E will be an output pin if the corresponding PEIORL bit is set to 1, and an input pin if the bit is cleared to 0.

The initial value of PEIORL is H'0000.

17.1.10 Port E Control Registers L1, L2 (PECRL1, PECRL2)

The port E control registers L1 and L2 (PECRL1 and PECRL2) are 16-bit readable/writable registers that are used to select the multiplexed pin function of the pins on port E.

- Port E Control Registers L1 and L2 (PECRL1 and PECRL2) in SH7144

| Register | Bit | Bit Name | Initial Value | R/W | Description |
|----------|-----|----------|---------------|-----|---|
| PECRL1 | 15 | PE15MD1 | 0 | R/W | PE15 Mode |
| PECRL1 | 14 | PE15MD0 | 0 | R/W | Select the function of the PE15/TIOC4D/DACK1/ $\overline{\text{IRQOUT}}$ pin. 00: PE15 I/O (port) 01: TIOC4D I/O (MTU) 10: DACK1 output (DMAC) 11: $\overline{\text{IRQOUT}}$ output (INTC) |
| PECRL1 | 13 | PE14MD1 | 0 | R/W | PE14 Mode |
| PECRL1 | 12 | PE14MD0 | 0 | R/W | Select the function of the PE14/TIOC4C/DACK0 pin. 00: PE14 I/O (port) 01: TIOC4C I/O (MTU) 10: DACK0 output (DMAC) 11: Setting prohibited |
| PECRL1 | 11 | PE13MD1 | 0 | R/W | PE13 Mode |
| PECRL1 | 10 | PE13MD0 | 0 | R/W | Select the function of the PE13/TIOC4B/ $\overline{\text{MRES}}$ pin. 00: PE13 I/O (port) 01: TIOC4B I/O (MTU) 10: $\overline{\text{MRES}}$ input (INTC) 11: Setting prohibited |
| PECRL1 | 9 | PE12MD1 | 0 | R/W | PE12 Mode |
| PECRL1 | 8 | PE12MD0 | 0 | R/W | Select the function of the PE12/TIOC4A/TXD3 pin. 00: PE12 I/O (port) 01: TIOC4A I/O (MTU) 10: Setting prohibited 11: TXD3 output (SCI) |

| Register | Bit | Bit Name | Initial Value | R/W | Description |
|----------|-----|----------|---------------|-----|--|
| PECRL1 | 7 | PE11MD1 | 0 | R/W | PE11 Mode |
| PECRL1 | 6 | PE11MD0 | 0 | R/W | Select the function of the PE11/TIOC3D/RXD3 pin. 00: PE11 I/O (port) 01: TIOC3D I/O (MTU) 10: Setting prohibited 11: RXD3 input (SCI) |
| PECRL1 | 5 | PE10MD1 | 0 | R/W | PE10 Mode |
| PECRL1 | 4 | PE10MD0 | 0 | R/W | Select the function of the PE10/TIOC3C/TXD2 pin. 00: PE10 I/O (port) 01: TIOC3C I/O (MTU) 10: TXD2 output (SCI) 11: Setting prohibited |
| PECRL1 | 3 | PE9MD1 | 0 | R/W | PE9 Mode |
| PECRL1 | 2 | PE9MD0 | 0 | R/W | Select the function of the PE9/TIOC3B/SCK3 pin. 00: PE9 I/O (port) 01: TIOC3B I/O (MTU) 10: Setting prohibited 11: SCK3 I/O (SCI) |
| PECRL1 | 1 | PE8MD1 | 0 | R/W | PE8 Mode |
| PECRL1 | 0 | PE8MD0 | 0 | R/W | Select the function of the PE8/TIOC3A/SCK2 pin. 00: PE8 I/O (port) 01: TIOC3A I/O (MTU) 10: SCK2 I/O (SCI) 11: Setting prohibited |
| PECRL2 | 15 | PE7MD1 | 0 | R/W | PE7 Mode |
| PECRL2 | 14 | PE7MD0 | 0 | R/W | Select the function of the PE7/TIOC2B/RXD2 pin. 00: PE7 I/O (port) 01: TIOC2B I/O (MTU) 10: RXD2 input (SCI) 11: Setting prohibited |

17. Pin Function Controller (PFC)

| Register | Bit | Bit Name | Initial Value | R/W | Description |
|----------|-----|----------|---------------|-----|---|
| PECRL2 | 13 | PE6MD1 | 0 | R/W | PE6 Mode |
| PECRL2 | 12 | PE6MD0 | 0 | R/W | Select the function of the PE6/TIOC2A/SCK3 pin. 00: PE6 I/O (port) 01: TIOC2A I/O (MTU) 10: SCK3 I/O (SCI) 11: Setting prohibited |
| PECRL2 | 11 | PE5MD1 | 0 | R/W | PE5 Mode |
| PECRL2 | 10 | PE5MD0 | 0 | R/W | Select the function of the PE5/TIOC1B/TXD3 pin. 00: PE5 I/O (port) 01: TIOC1B I/O (MTU) 10: TXD3 output (SCI) 11: Setting prohibited |
| PECRL2 | 9 | PE4MD1 | 0 | R/W | PE4 Mode |
| PECRL2 | 8 | PE4MD0 | 0 | R/W | Select the function of the PE4/TIOC1A/RXD3/TCK pin. Fixed to TCK input when using E10A (in DBGMD = high).* 00: PE4 I/O (port) 01: TIOC1A I/O (MTU) 10: RXD3 input (SCI) 11: Setting prohibited |
| PECRL2 | 7 | PE3MD1 | 0 | R/W | PE3 Mode |
| PECRL2 | 6 | PE3MD0 | 0 | R/W | Select the function of the PE3/TIOC0D/DRAK1/TDO pin. Fixed to TDO output when using E10A (in DBGMD = high).* 00: PE3 I/O (port) 01: TIOC0D I/O (MTU) 10: DRAK1 output (DMAC) 11: Setting prohibited |

| Register | Bit | Bit Name | Initial Value | R/W | Description |
|----------|-----|----------|---------------|-----|---|
| PECRL2 | 5 | PE2MD1 | 0 | R/W | PE2 Mode |
| PECRL2 | 4 | PE2MD0 | 0 | R/W | Select the function of the PE2/TIOC0C/ $\overline{\text{DREQ1}}$ /TDI pin. Fixed to TDI input when using E10A (in DBGMD = high).* 00: PE2 I/O (port) 01: TIOC0C I/O (MTU) 10: $\overline{\text{DREQ1}}$ input (DMAC) 11: Setting prohibited |
| PECRL2 | 3 | PE1MD1 | 0 | R/W | PE1 Mode |
| PECRL2 | 2 | PE1MD0 | 0 | R/W | Select the function of the PE1/TIOC0B/DRAK0/ $\overline{\text{TRST}}$ pin. Fixed to $\overline{\text{TRST}}$ input when using E10A (in DBGMD = high).* 00: PE1 I/O (port) 01: TIOC0B I/O (MTU) 10: DRAK0 output (DMAC) 11: Setting prohibited |
| PECRL2 | 1 | PE0MD1 | 0 | R/W | PE0 Mode |
| PECRL2 | 0 | PE0MD0 | 0 | R/W | Select the function of the PE0/TIOC0A/ $\overline{\text{DREQ0}}$ /TMS pin. Fixed to TMS input when using E10A (in DBGMD = high).* 00: PE0 I/O (port) 01: TIOC0A I/O (MTU) 10: $\overline{\text{DREQ0}}$ input (DMAC) 11: Setting prohibited |

Note: * F-ZTAT version only. Setting prohibited for the masked ROM version and ROM less version.

- Port E Control Registers L1 and L2 (PECRL1 and PECRL2) in SH7145

| Register | Bit | Bit Name | Initial Value | R/W | Description |
|----------|-----|----------|---------------|-----|---|
| PECRL1 | 15 | PE15MD1 | 0 | R/W | PE15 Mode |
| PECRL1 | 14 | PE15MD0 | 0 | R/W | Select the function of the PE15/TIOC4D/DACK1/ $\overline{\text{IRQOUT}}$ pin. 00: PE15 I/O (port) 01: TIOC4D I/O (MTU) 10: DACK1 output (DMAC) 11: $\overline{\text{IRQOUT}}$ output (INTC) |
| PECRL1 | 13 | PE14MD1 | 0 | R/W | PE14 Mode |
| PECRL1 | 12 | PE14MD0 | 0 | R/W | Select the function of the PE14/TIOC4C/DACK0 pin. 00: PE14 I/O (port) 01: TIOC4C I/O (MTU) 10: DACK0 output (DMAC) 11: Setting prohibited |
| PECRL1 | 11 | PE13MD1 | 0 | R/W | PE13 Mode |
| PECRL1 | 10 | PE13MD0 | 0 | R/W | Select the function of the PE13/TIOC4B/ $\overline{\text{MRES}}$ pin. 00: PE13 I/O (port) 01: TIOC4B I/O (MTU) 10: $\overline{\text{MRES}}$ input (INTC) 11: Setting prohibited |
| PECRL1 | 9 | PE12MD1 | 0 | R/W | PE12 Mode |
| PECRL1 | 8 | PE12MD0 | 0 | R/W | Select the function of the PE12/TIOC4A/TCK/TXD3 pin. Fixed to TCK input when using E10A (in DBGMD = high).* 00: PE12 I/O (port) 01: TIOC4A I/O (MTU) 10: Setting prohibited 11: TXD3 output (SCI) |

| Register | Bit | Bit Name | Initial Value | R/W | Description |
|----------|-----|----------|---------------|-----|---|
| PECRL1 | 7 | PE11MD1 | 0 | R/W | PE11 Mode |
| PECRL1 | 6 | PE11MD0 | 0 | R/W | Select the function of the PE11/TIOC3D/TDO/RXD3 pin. Fixed to TDO output when using E10A (in DBGMD = high).* 00: PE11 I/O (port) 01: TIOC3D I/O (MTU) 10: Setting prohibited 11: RXD3 input (SCI) |
| PECRL1 | 5 | PE10MD1 | 0 | R/W | PE10 Mode |
| PECRL1 | 4 | PE10MD0 | 0 | R/W | Select the function of the PE10/TIOC3C/TXD2/TDI pin. Fixed to TDI input when using E10A (in DBGMD = high).* 00: PE10 I/O (port) 01: TIOC3C I/O (MTU) 10: TXD2 output (SCI) 11: Setting prohibited |
| PECRL1 | 3 | PE9MD1 | 0 | R/W | PE9 Mode |
| PECRL1 | 2 | PE9MD0 | 0 | R/W | Select the function of the PE9/TIOC3B/TRST/SCK3 pin. Fixed to $\overline{\text{TRST}}$ input when using E10A (in DBGMD = high).* 00: PE9 I/O (port) 01: TIOC3B I/O (MTU) 10 Setting prohibited 11: SCK3 I/O (SCI) |
| PECRL1 | 1 | PE8MD1 | 0 | R/W | PE8 Mode |
| PECRL1 | 0 | PE8MD0 | 0 | R/W | Select the function of the PE8/TIOC3A/SCK2/TMS pin. Fixed to TMS input when using E10A (in DBGMD = high).* 00: PE8 I/O (port) 01: TIOC3A I/O (MTU) 10: SCK2 I/O (SCI) 11: Setting prohibited |

17. Pin Function Controller (PFC)

| Register | Bit | Bit Name | Initial Value | R/W | Description |
|----------|-----|----------|---------------|-----|---|
| PECRL2 | 15 | PE7MD1 | 0 | R/W | PE7 Mode |
| PECRL2 | 14 | PE7MD0 | 0 | R/W | Select the function of the PE7/TIOC2B/RXD2 pin. 00: PE7 I/O (port) 01: TIOC2B I/O (MTU) 10: RXD2 input (SCI) 11: Setting prohibited |
| PECRL2 | 13 | PE6MD1 | 0 | R/W | PE6 Mode |
| PECRL2 | 12 | PE6MD0 | 0 | R/W | Select the function of the PE6/TIOC2A/SCK3/AUDATA0 pin. 00: PE6 I/O (port) 01: TIOC2A I/O (MTU) 10: SCK3 I/O (SCI) 11: AUDATA0 I/O (AUD)* |
| PECRL2 | 11 | PE5MD1 | 0 | R/W | PE5 Mode |
| PECRL2 | 10 | PE5MD0 | 0 | R/W | Select the function of the PE5/TIOC1B/TXD3/AUDATA1 pin. 00: PE5 I/O (port) 01: TIOC1B I/O (MTU) 10: TXD3 output (SCI) 11: AUDATA1 I/O (AUD)* |
| PECRL2 | 9 | PE4MD1 | 0 | R/W | PE4 Mode |
| PECRL2 | 8 | PE4MD0 | 0 | R/W | Select the function of the PE4/TIOC1A/RXD3/AUDATA2 pin. 00: PE4 I/O (port) 01: TIOC1A I/O (MTU) 10: RXD3 input (SCI) 11: AUDATA2 I/O (AUD)* |
| PECRL2 | 7 | PE3MD1 | 0 | R/W | PE3 Mode |
| PECRL2 | 6 | PE3MD0 | 0 | R/W | Select the function of the PE3/TIOC0D/DRAK1/AUDATA3 pin. 00: PE3 I/O (port) 01: TIOC0D I/O (MTU) 10: DRAK1 output (DMAC) 11: AUDATA3 I/O (AUD)* |

| Register | Bit | Bit Name | Initial Value | R/W | Description |
|----------|-----|----------|---------------|-----|--|
| PECRL2 | 5 | PE2MD1 | 0 | R/W | PE2 Mode |
| PECRL2 | 4 | PE2MD0 | 0 | R/W | Select the function of the PE2/TIOC0C/DREQ1/AUDRST pin. 00: PE2 I/O (port) 01: TIOC0C I/O (MTU) 10: DREQ1 input (DMAC) 11: AUDRST input (AUD)* |
| PECRL2 | 3 | PE1MD1 | 0 | R/W | PE1 Mode |
| PECRL2 | 2 | PE1MD0 | 0 | R/W | Select the function of the PE1/TIOC0B/DRAK0/AUDMD pin. 00: PE1 I/O (port) 01: TIOC0B I/O (MTU) 10: DRAK0 output (DMAC) 11: AUDMD input (AUD)* |
| PECRL2 | 1 | PE0MD1 | 0 | R/W | PE0 Mode |
| PECRL2 | 0 | PE0MD0 | 0 | R/W | Select the function of the PE0/TIOC0A/DREQ0/AUDCK pin. 00: PE0 I/O (port) 01: TIOC0A I/O (MTU) 10: DREQ0 input (DMAC) 11: AUDCK I/O (AUD)* |

Note: * F-ZTAT version only. Setting prohibited for the masked ROM version and ROM less version.

17.1.11 High-Current Port Control Register (PPCR)

The high-current port control register (PPCR) is an 8-bit readable/writable register that is used to control six pins (PE9/TIOC3B/SCK3/TRST*, PE11/TIOC3D/RXD3/TDO*, PE12/TIOC4A/TXD3/TCK*, PE13/TIOC4B/MRES, PE14/TIOC4C/DACK0, PE15/TIOC4D/DACK1/IRQOUT) of the high-current ports.

This register is not supported in the emulator. Bits are always read as undefined in the emulator.

Note: * Only in the SH7145

| Bit | Bit Name | Initial Value | R/W | Description |
|--------|----------|---------------|-----|--|
| 7 to 1 | — | All 0 | R | Reserved These bits are always read as 0. The write value should always be 0. |
| 0 | MZIZE | 0 | R/W | High-Current Port High-Impedance This bit selects whether or not the high-current ports are set to high-impedance regardless of the PFC setting when detecting oscillation halt or in software standby mode. 0: Set to high-impedance 1: Not set to high-impedance If this bit is set to 1, the pin state is retained when detecting oscillation halt. For the pin state in software standby mode, refer to appendix A, Pin States. |

17.2 Usage Notes

1. In this LSI, the same function is available as a multiplexed function on multiple pins. This approach is intended to increase the number of selectable pin functions and to allow the easier design of boards. If two or more pins are specified for one function, however, there are two cautions shown below.

— When the pin function is input

Signals input to several pins are formed as one signal through OR or AND logic and the signal is transmitted into the LSI. Therefore, a signal that differs from the input signals may be transmitted to the LSI depending on the input signals in other pins that have the same functions. Table 17.15 shows the transmit forms of input functions allocated to several pins. When using one of the functions shown below in multiple pins, use it with care of signal polarity considering the transmit forms.

Table 17.15 Transmit Forms of Input Functions Allocated to Multiple Pins

| Product | OR Type | AND Type |
|---------|--|---|
| SH7144 | SCK3, RXD3 | $\overline{\text{IRQ0}}$ to $\overline{\text{IRQ3}}$, $\overline{\text{DREQ0}}$, $\overline{\text{DREQ1}}$ |
| SH7145 | SCK3, RXD3, AUDMD*, AUDATA0 to AUDATA3* | $\overline{\text{IRQ0}}$ to $\overline{\text{IRQ7}}$, $\overline{\text{DREQ0}}$, $\overline{\text{DREQ1}}$, $\overline{\text{BREQ}}$, $\overline{\text{WAIT}}$, $\overline{\text{ADTRG}}$, $\overline{\text{AUDRST}}^*$, $\overline{\text{AUDSYNC}}^*$, $\overline{\text{AUDCK}}^*$ |

Note: * F-ZTAT version only

OR type: Signals input to several pins are formed as one signal through OR logic and the signal is transmitted into the LSI.

AND type: Signals input to several pins are formed as one signal through AND logic and the signal is transmitted into the LSI.

— When the pin function is output

Each selected pin can output the same function.

2. When the port input is switched from a low level to the $\overline{\text{DREQ}}$ or the $\overline{\text{IRQ}}$ edge for the pins that are multiplexed with input/output and $\overline{\text{DREQ}}$ or $\overline{\text{IRQ}}$, the corresponding edge is detected.
3. Do not set functions other than those specified in tables 17.13 and 17.14. Otherwise, correct operation cannot be guaranteed.
4. When pin functions are selected, set the port I/O registers (PBIOR and PDIORL) after setting the port control registers (PBCR1, PBCR2, PDCRL1, and PDCRL2).

However, when selecting pin functions that are multiplexed with port A, port C, PD31 to PD16 of port D, and port E, no strict attention is required in setting the order of port control registers (PACRH, PACRL1, PACRL2, PCCR, PDCRH1, PDCRH2, PECRL1, and PECRL2) and port I/O registers (PAIORH, PAIORL, PCIOR, PDIORH, and PEIORL).

5. When the system uses the external space, the data I/O pins must be set as follows according to the bus sizes in the CS space set by the bus control register 1 (BCR1).
 - When the CS space is the byte size (8-bit size), set all pins, D7 to D0, as data I/O pins.
 - When the CS space is the word size (16-bit size), set all pins, D15 to D0, as data I/O pins.
 - When the CS space is the longword size (32-bit size), set all pins, D31 to D0, as data I/O pins.

If the contents in the external space are read by settings other than above ways, no correct data can be latched. This note applies to entire space, CS0 to CS7.
6. If a power-on reset is input to the $\overline{\text{RES}}$ pin in the state where the pin is a general output pin and set to output 1 (that is, the port control register is in the general I/O state, port I/O register is 1, and port data register is 1), a low level may occur in the pin at a power-on reset input. To avoid this low level from occurring, input a power-on reset after clearing the port I/O register to 0 (general input). The low level above will not occur when an internal power-on reset is input due to a WDT overflow.

Section 18 I/O Ports

The SH7144 has six ports: A to F. Ports A, C, D, and E are 16-bit ports, and port B is a 10-bit port. Port F is an 8-bit input-only port.

The SH7145 has six ports: A to F. Port A is a 24-bit port, port B is a 10-bit port, port C is a 16-bit port, port D is a 32-bit port, and port E is a 16-bit port. Port F is an 8-bit input-only port.

All the port pins are multiplexed as general input/output pins and special function pins. The functions of the multiplex pins are selected by means of the pin function controller (PFC). Each port is provided with a data register for storing the pin data.

18.1 Port A

Port A in the SH7144 is an input/output port with the 16 pins shown in figure 18.1.

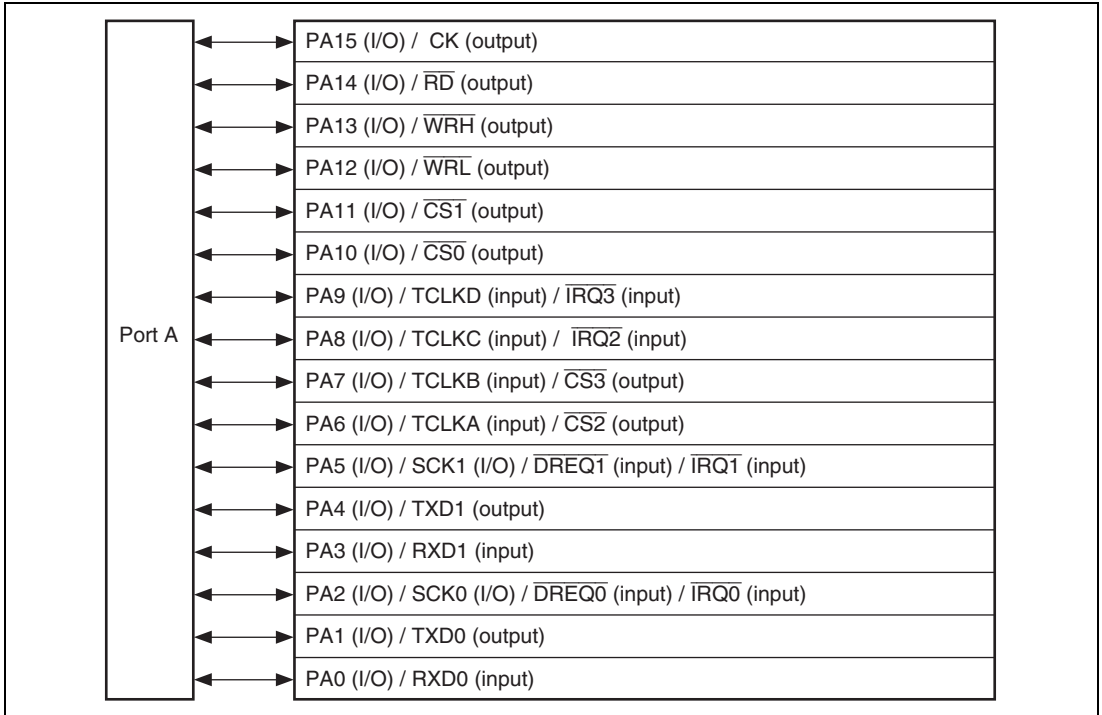

Figure 18.1 Port A (SH7144)

Port A in the SH7145 is an input/output port with the 24 pins shown in figure 18.2

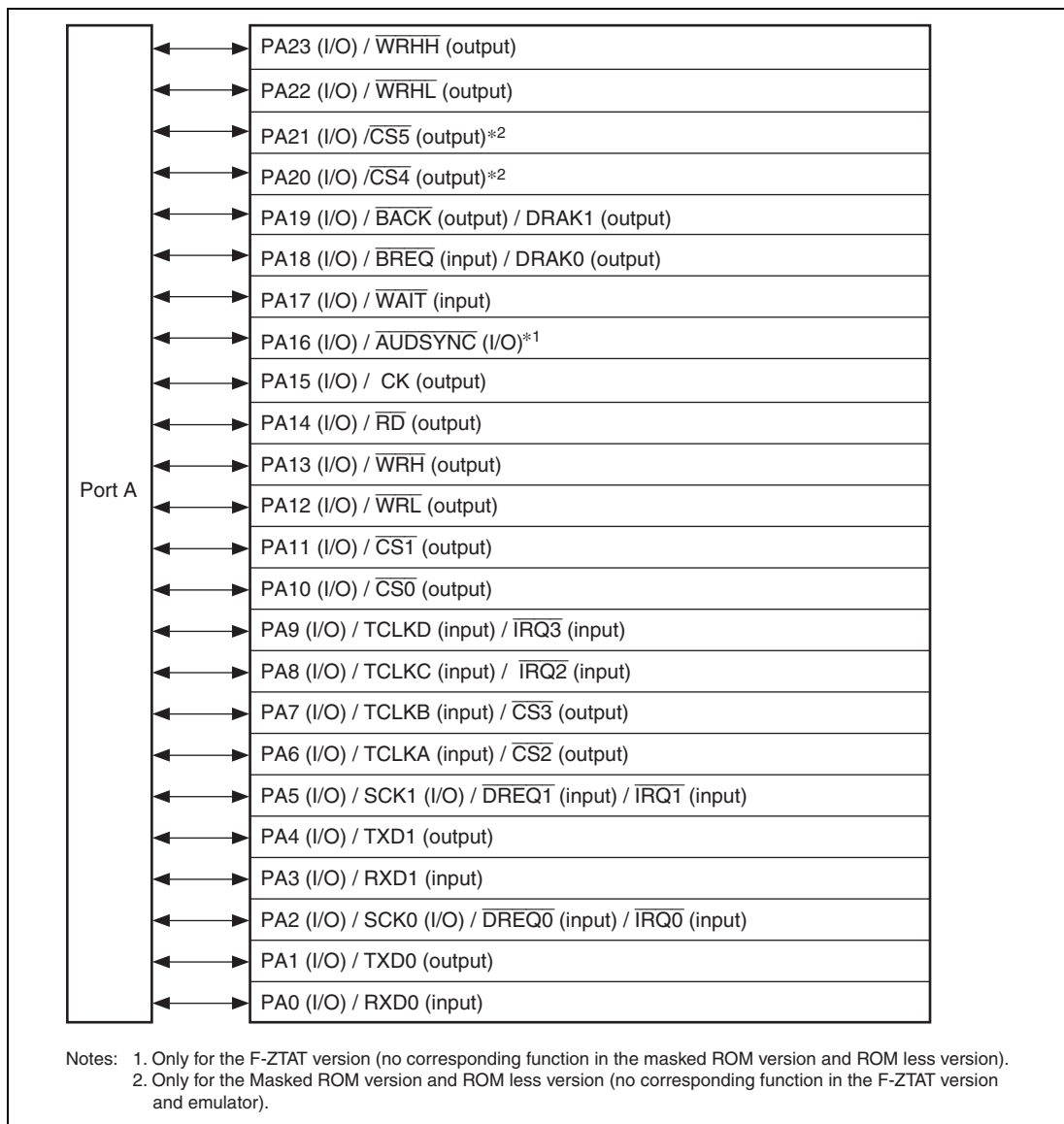

Figure 18.2 Port A (SH7145)

18.1.1 Register Descriptions

Port A is a 16-bit input/output port in the SH7144; a 24-bit input/output port in the SH7145. Port A has the following registers. For details on register addresses and register states during each processing, refer to section 25, List of Registers.

- Port A data register H (PADRH)
- Port A data register L (PADRL)

18.1.2 Port A Data Registers H and L (PADRH and PADRL)

The port A data registers H and L (PADRH and PADRL) are 16-bit readable/writable registers that store port A data. Bits PA15DR to PA0DR correspond to pins PA15 to PA0 (multiplexed functions omitted here) in the SH7144. Bits PA23DR to PA0DR correspond to pins PA23 to PA0 (multiplexed functions omitted here) in the SH7145.

When a pin functions is a general output, if a value is written to PADRH or PADRL, that value is output directly from the pin, and if PADRH or PADRL is read, the register value is returned directly regardless of the pin state.

When a pin functions is a general input, if PADRH or PADRL is read, the pin state, not the register value, is returned directly. If a value is written to PADRH or PADRL, although that value is written into PADRH or PADRL, it does not affect the pin state. Table 18.1 summarizes port A data register L read/write operations.

- PADRH

| Bit | Bit Name | Initial Value | R/W | Description |
|---------|----------|---------------|-----|--|
| 15 to 8 | — | All 0 | R | Reserved These bits are always read as 0. The write value should always be 0. |
| 7 | PA23DR | 0 | R/W | See table 18.1* |
| 6 | PA22DR | 0 | R/W | |
| 5 | PA21DR | 0 | R/W | |
| 4 | PA20DR | 0 | R/W | |
| 3 | PA19DR | 0 | R/W | |
| 2 | PA18DR | 0 | R/W | |
| 1 | PA17DR | 0 | R/W | |
| 0 | PA16DR | 0 | R/W | |

Note: * These bits are reserved in the SH7144. They are always read as 0 and the write value should always be 0.

- PADRL

| Bit | Bit Name | Initial Value | R/W | Description |
|-----|----------|---------------|-----|----------------|
| 15 | PA15DR | 0 | R/W | See table 18.1 |
| 14 | PA14DR | 0 | R/W | |
| 13 | PA13DR | 0 | R/W | |
| 12 | PA12DR | 0 | R/W | |
| 11 | PA11DR | 0 | R/W | |
| 10 | PA10DR | 0 | R/W | |
| 9 | PA9DR | 0 | R/W | |
| 8 | PA8DR | 0 | R/W | |
| 7 | PA7DR | 0 | R/W | |
| 6 | PA6DR | 0 | R/W | |
| 5 | PA5DR | 0 | R/W | |
| 4 | PA4DR | 0 | R/W | |
| 3 | PA3DR | 0 | R/W | |
| 2 | PA2DR | 0 | R/W | |
| 1 | PA1DR | 0 | R/W | |
| 0 | PA0DR | 0 | R/W | |

Table 18.1 Port A Data Register (PADR) Read/Write Operations

- PADRH bits 7 to 0 and PADRL bits 15 to 0

| PAIORL, H | Pin Function | Read | Write |
|------------------|---------------------------|------------------|---|
| 0 | General input | Pin state | Can write to PADRH and PADRL, but it has no effect on pin state |
| | Other than general input | Pin state | Can write to PADRH and PADRL, but it has no effect on pin state |
| 1 | General output | PADRH or L value | Value written is output from pin |
| | Other than general output | PADRH or L value | Can write to PADRH and PADRL, but it has no effect on pin state |

18.2 Port B

Port B is an input/output port with the 10 pins shown in figure 18.3.

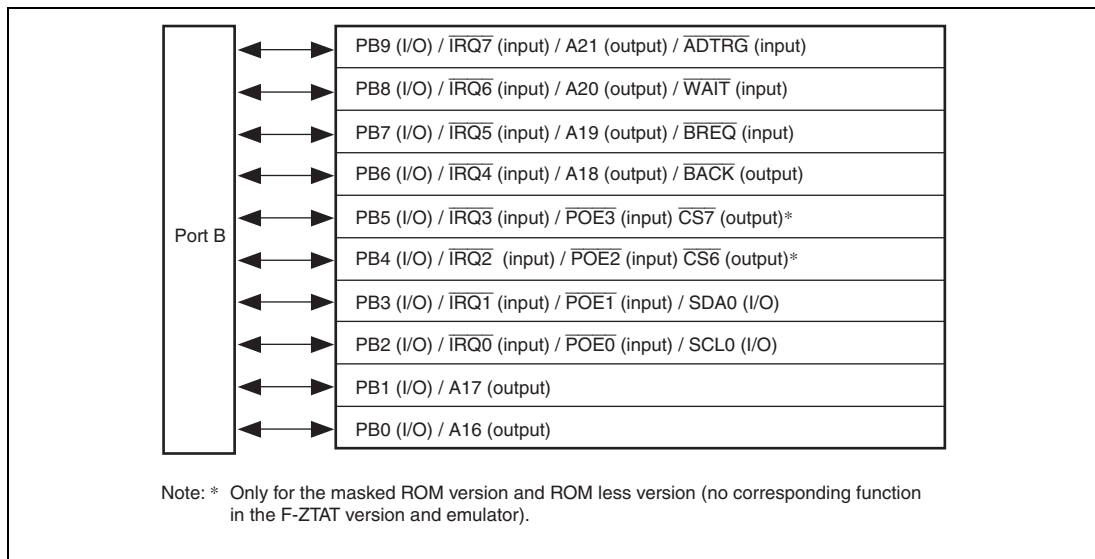

Figure 18.3 Port B

18.2.1 Register Descriptions

Port B is a 10-bit input/output port. Port B has the following register. For details on register addresses and register states during each processing, refer to section 25, List of Registers.

- Port B data register (PBDR)

18.2.2 Port B Data Register (PBDR)

The port B data register (PBDR) is a 16-bit readable/writable register that stores port B data. Bits PB9DR to PB0DR correspond to pins PB9 to PB0 (multiplexed functions omitted here).

When a pin functions is a general output, if a value is written to PBDR, that value is output directly from the pin, and if PBDR is read, the register value is returned directly regardless of the pin state.

When a pin functions is a general input, if PBDR is read, the pin state, not the register value, is returned directly. If a value is written to PBDR, although that value is written into PBDR, it does not affect the pin state. Table 18.2 summarizes port B data register read/write operations.

| Bit | Bit Name | Initial Value | R/W | Description |
|----------|----------|---------------|-----|--|
| 15 to 10 | — | All 0 | R | Reserved These bits are always read as 0. The write value should always be 0. |
| 9 | PB9DR | 0 | R/W | See table 18.2 |
| 8 | PB8DR | 0 | R/W | |
| 7 | PB7DR | 0 | R/W | |
| 6 | PB6DR | 0 | R/W | |
| 5 | PB5DR | 0 | R/W | |
| 4 | PB4DR | 0 | R/W | |
| 3 | PB3DR | 0 | R/W | |
| 2 | PB2DR | 0 | R/W | |
| 1 | PB1DR | 0 | R/W | |
| 0 | PB0DR | 0 | R/W | |

Table 18.2 Port B Data Register (PBDR) Read/Write Operations

- Bits 9 to 0

| PBIOR | Pin Function | Read | Write |
|--------------|---------------------------|-------------|--|
| 0 | General input | Pin state | Can write to PBDR, but it has no effect on pin state |
| | Other than general input | Pin state | Can write to PBDR, but it has no effect on pin state |
| 1 | General output | PBDR value | Value written is output from pin |
| | Other than general output | PBDR value | Can write to PBDR, but it has no effect on pin state |

18.3 Port C

Port C is an input/output port with 16 pins shown in figure 18.4.

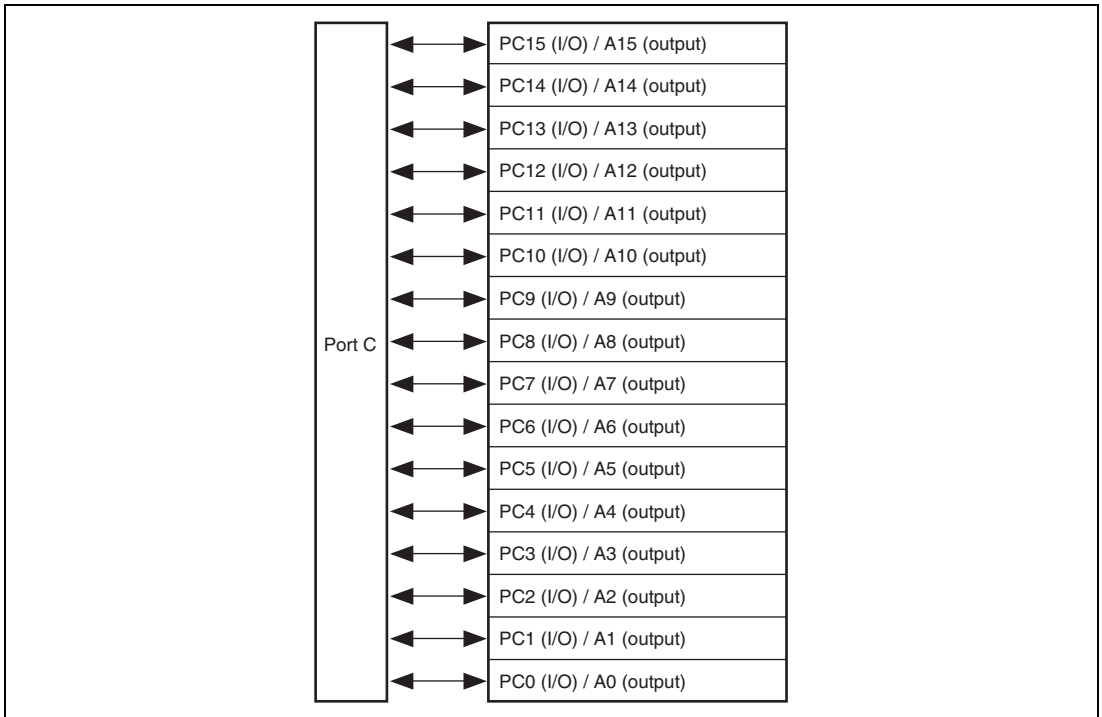

Figure 18.4 Port C

18.3.1 Register Descriptions

Port C is a 16-bit input/output port. Port C has the following register. For details on register addresses and register states during each processing, refer to section 25, List of Registers.

- Port C data register (PCDR)

18.3.2 Port C Data Register (PCDR)

The port C data register (PCDR) is a 16-bit readable/writable register that stores port C data. Bits PC15DR to PC0DR correspond to pins PC15 to PC0 (multiplexed functions omitted here).

When a pin functions as a general output, if a value is written to PCDR, that value is output directly from the pin, and if PCDR is read, the register value is returned directly regardless of the pin state.

When a pin function is a general input, if PCDR is read, the pin state, not the register value, is returned directly. If a value is written to PCDR, although that value is written into PCDR, it does not affect the pin state. Table 18.3 summarizes port C data register read/write operations.

- PCDR

| Bit | Bit Name | Initial Value | R/W | Description |
|-----|----------|---------------|-----|----------------|
| 15 | PC15DR | 0 | R/W | See table 18.3 |
| 14 | PC14DR | 0 | R/W | |
| 13 | PC13DR | 0 | R/W | |
| 12 | PC12DR | 0 | R/W | |
| 11 | PC11DR | 0 | R/W | |
| 10 | PC10DR | 0 | R/W | |
| 9 | PC9DR | 0 | R/W | |
| 8 | PC8DR | 0 | R/W | |
| 7 | PC7DR | 0 | R/W | |
| 6 | PC6DR | 0 | R/W | |
| 5 | PC5DR | 0 | R/W | |
| 4 | PC4DR | 0 | R/W | |
| 3 | PC3DR | 0 | R/W | |
| 2 | PC2DR | 0 | R/W | |
| 1 | PC1DR | 0 | R/W | |
| 0 | PC0DR | 0 | R/W | |

Table 18.3 Port C Data Register (PCDR) Read/Write Operations

- Bits 15 to 0

| PCIOR | Pin Function | Read | Write |
|--------------|---------------------------|-------------|--|
| 0 | General input | Pin state | Can write to PCDR, but it has no effect on pin state |
| | Other than general input | Pin state | Can write to PCDR, but it has no effect on pin state |
| 1 | General output | PCDR value | Value written is output from pin |
| | Other than general output | PCDR value | Can write to PCDR, but it has no effect on pin state |

18.4 Port D

Port D of the SH7144 is an input/output port with 16 pins shown in figure 18.5.

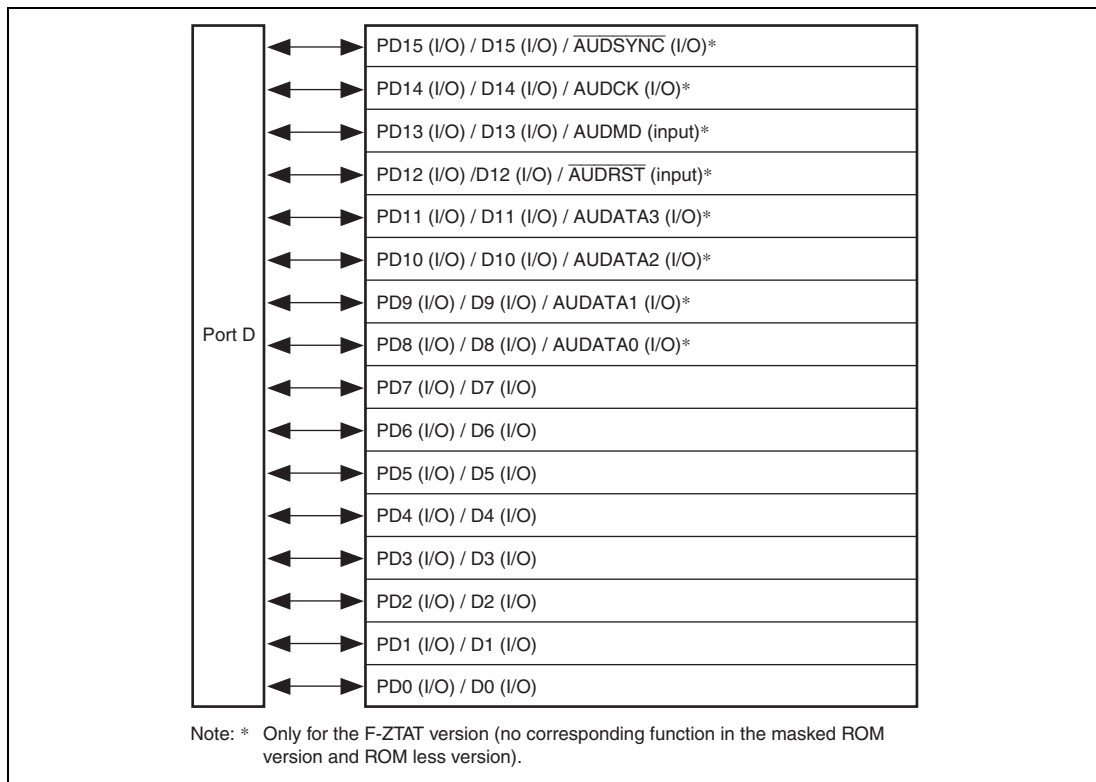

Figure 18.5 Port D (SH7144)

Port D of the SH7145 is an input/output port with 32 pins shown in figure 18.6.

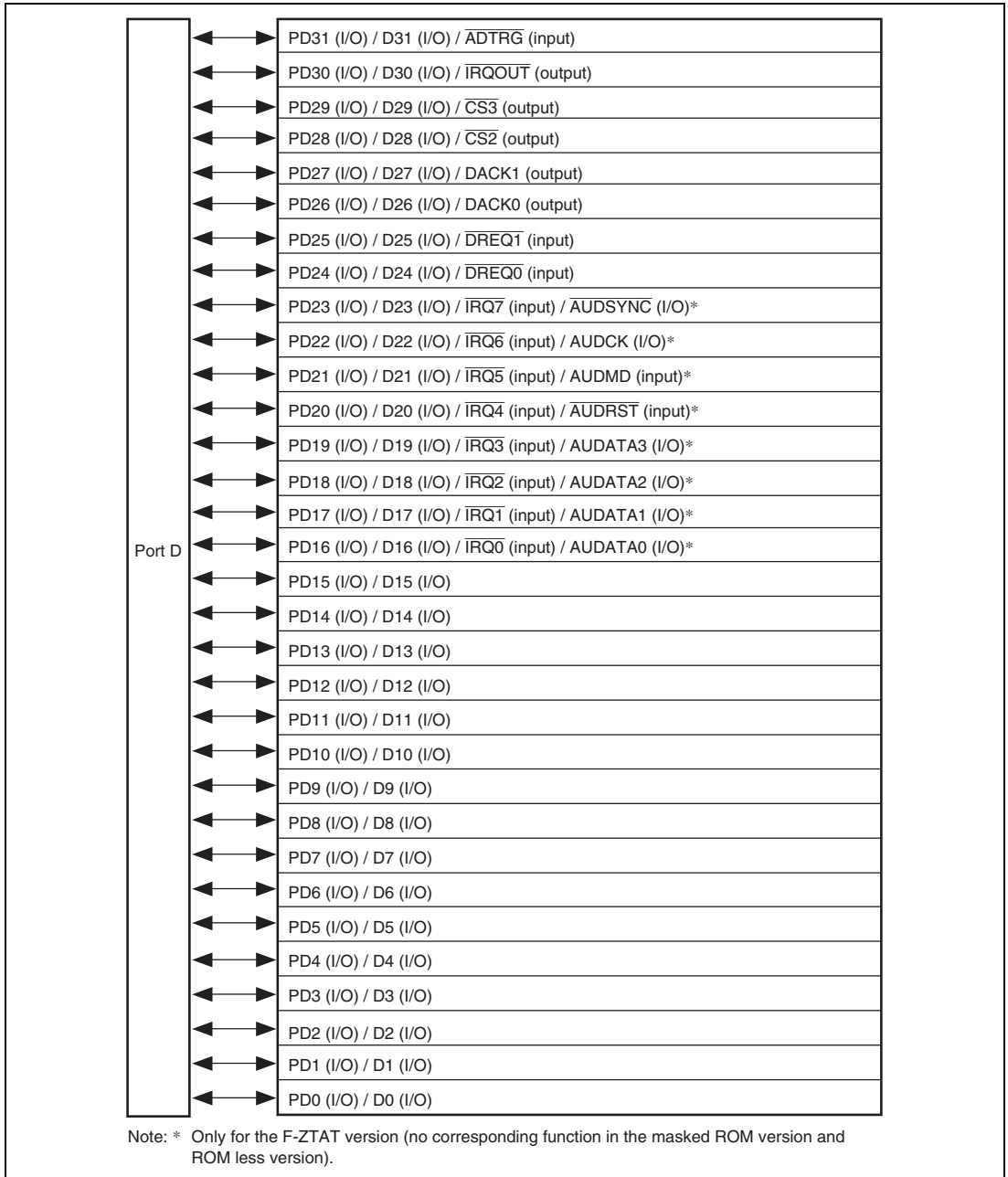

Figure 18.6 Port D (SH7145)

18.4.1 Register Descriptions

Port D is a 16-bit input/output port in the SH7144; a 32-bit input/output port in the SH7145. Port D has the following registers. For details on register addresses and register states during each processing, refer to section 25, List of Registers.

- Port D data register H (PDDRH)
- Port D data register L (PDDRL)

18.4.2 Port D Data Registers H and L (PDDRH and PDDRL)

The port D data registers H and L (PDDRH and PDDRL) are 16-bit readable/writable registers that store port D data. Bits PD15DR to PD0DR correspond to pins PD15 to PD0 (multiplexed functions omitted here) in the SH7144. Bits PD31DR to PD0DR correspond to pins PD31 to PD0 (multiplexed functions omitted here) in the SH7145.

When a pin functions is a general output, if a value is written to PDDRH or PDDRL, that value is output directly from the pin, and if PDDRH or PDDRL is read, the register value is returned directly regardless of the pin state.

When a pin functions is a general input, if PDDRH or PDDRL is read, the pin state, not the register value, is returned directly. If a value is written to PDDRH or PDDRL, although that value is written into PDDRH or PDDRL, it does not affect the pin state. Table 18.4 summarizes port D data register L read/write operations.

• PDDRH

| Bit | Bit Name | Initial Value | R/W | Description |
|-----|----------|---------------|-----|-----------------|
| 15 | PD31DR | 0 | R/W | See table 18.4* |
| 14 | PD30DR | 0 | R/W | |
| 13 | PD29DR | 0 | R/W | |
| 12 | PD28DR | 0 | R/W | |
| 11 | PD27DR | 0 | R/W | |
| 10 | PD26DR | 0 | R/W | |
| 9 | PD25DR | 0 | R/W | |
| 8 | PD24DR | 0 | R/W | |
| 7 | PD23DR | 0 | R/W | |
| 6 | PD22DR | 0 | R/W | |
| 5 | PD21DR | 0 | R/W | |
| 4 | PD20DR | 0 | R/W | |
| 3 | PD19DR | 0 | R/W | |
| 2 | PD18DR | 0 | R/W | |
| 1 | PD17DR | 0 | R/W | |
| 0 | PD16DR | 0 | R/W | |

Note: * These bits are reserved in the SH7144. They are always read as 0 and the write value should always be 0.

- PDDRL

| Bit | Bit Name | Initial Value | R/W | Description |
|-----|----------|---------------|-----|----------------|
| 15 | PD15DR | 0 | R/W | See table 18.4 |
| 14 | PD14DR | 0 | R/W | |
| 13 | PD13DR | 0 | R/W | |
| 12 | PD12DR | 0 | R/W | |
| 11 | PD11DR | 0 | R/W | |
| 10 | PD10DR | 0 | R/W | |
| 9 | PD9DR | 0 | R/W | |
| 8 | PD8DR | 0 | R/W | |
| 7 | PD7DR | 0 | R/W | |
| 6 | PD6DR | 0 | R/W | |
| 5 | PD5DR | 0 | R/W | |
| 4 | PD4DR | 0 | R/W | |
| 3 | PD3DR | 0 | R/W | |
| 2 | PD2DR | 0 | R/W | |
| 1 | PD1DR | 0 | R/W | |
| 0 | PD0DR | 0 | R/W | |

Table 18.4 Port D Data Register (PDDR) Read/Write Operations

- PDDRH bits 15 to 0 and PDDRL bits 15 to 0

| PDIORL, H | Pin Function | Read | Write |
|-----------|---------------------------|------------------|--|
| 0 | General input | Pin state | Can write to PDDRH or PDDRL, but it has no effect on pin state |
| | Other than general input | Pin state | Can write to PDDRH or PDDRL, but it has no effect on pin state |
| 1 | General output | PDDRH or L value | Value written is output from pin |
| | Other than general output | PDDRH or L value | Can write to PDDRH or PDDRL, but it has no effect on pin state |

18.5 Port E

Port E in the SH7144 is an input/output port with the 16 pins shown in figure 18.7.

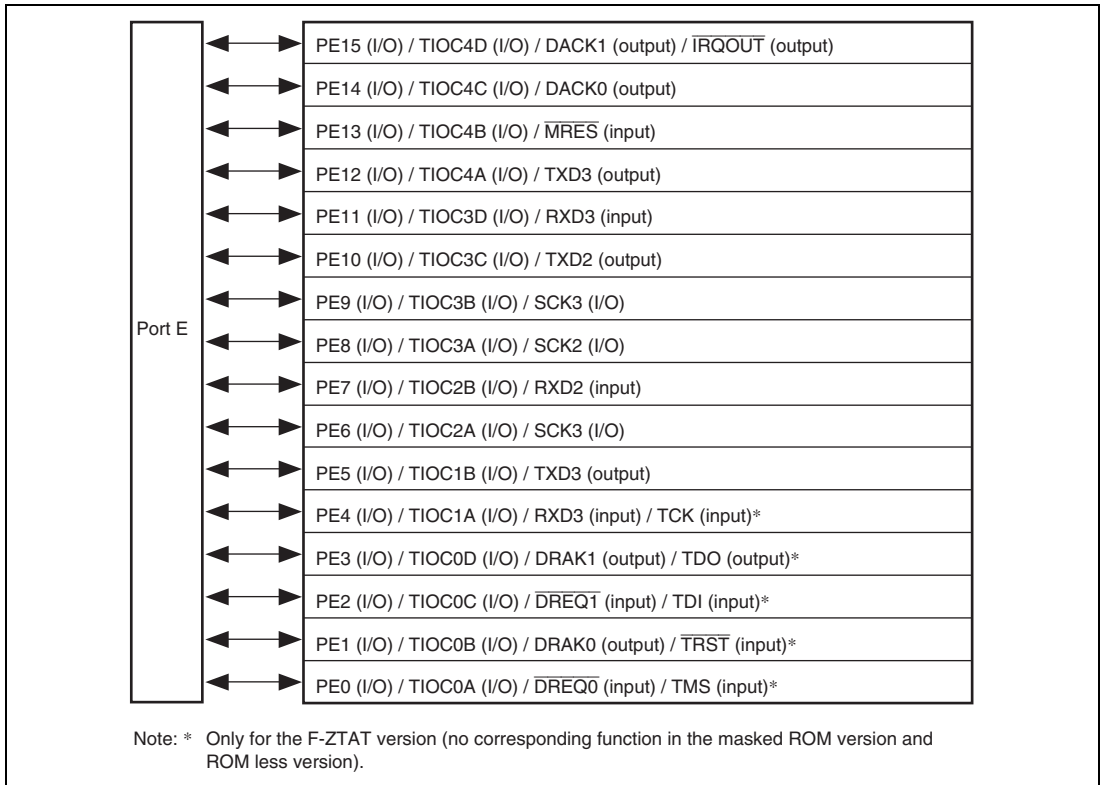

Figure 18.7 Port E (SH7144)

Port E in the SH7145 is an input/output port with the 16 pins shown in figure 18.8.

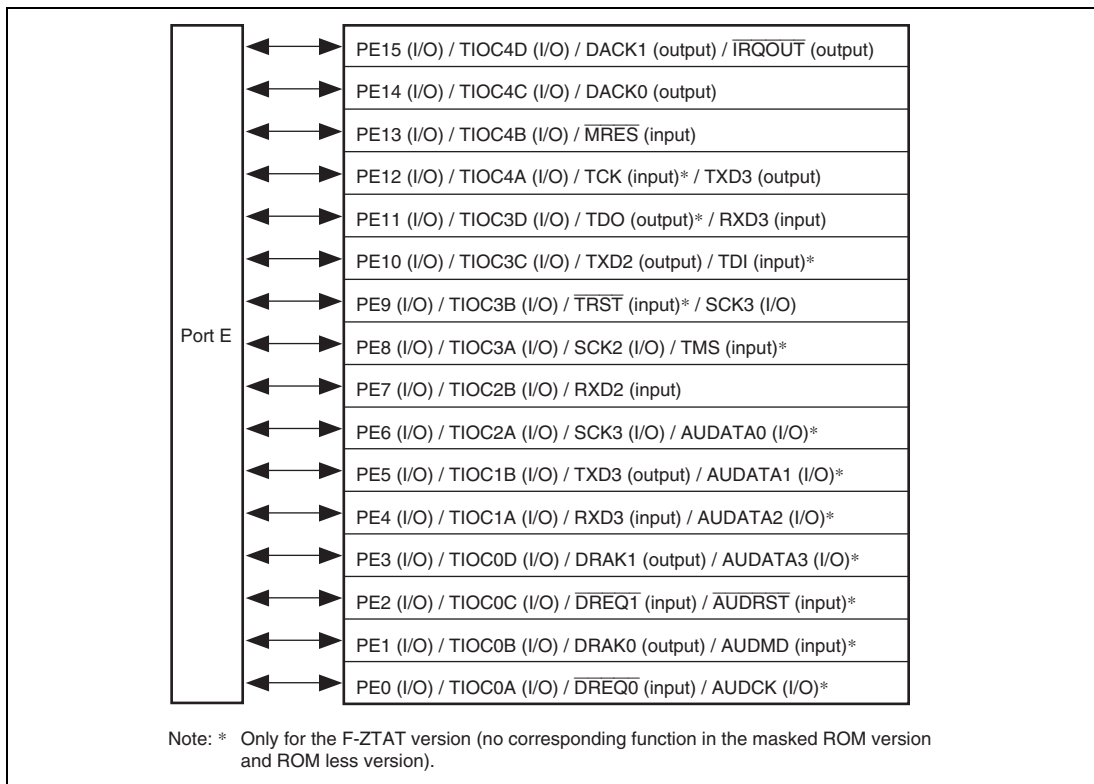

Figure 18.8 Port E (SH7145)

18.5.1 Register Descriptions

Port E has the following register. For details on register addresses and register states during each processing, refer to section 25, List of Registers.

- Port E data register L (PEDRL)

18.5.2 Port E Data Register L (PEDRL)

The port E data register L (PEDRL) is a 16-bit readable/writable registers that stores port E data. Bits PE15DR to PE0DR correspond to pins PE15 to PE0 (multiplexed functions omitted here).

When a pin functions is a general output, if a value is written to PEDRL, that value is output directly from the pin, and if PEDRL is read, the register value is returned directly regardless of the pin state.

When a pin functions is a general input, if PEDRL is read, the pin state, not the register value, is returned directly. If a value is written to PEDRL, although that value is written into PEDRL it does not affect the pin state. Table 18.5 summarizes port E data register read/write operations.

- PEDRL

| Bit | Bit Name | Initial Value | R/W | Description |
|-----|----------|---------------|-----|----------------|
| 15 | PE15DR | 0 | R/W | See table 18.5 |
| 14 | PE14DR | 0 | R/W | |
| 13 | PE13DR | 0 | R/W | |
| 12 | PE12DR | 0 | R/W | |
| 11 | PE11DR | 0 | R/W | |
| 10 | PE10DR | 0 | R/W | |
| 9 | PE9DR | 0 | R/W | |
| 8 | PE8DR | 0 | R/W | |
| 7 | PE7DR | 0 | R/W | |
| 6 | PE6DR | 0 | R/W | |
| 5 | PE5DR | 0 | R/W | |
| 4 | PE4DR | 0 | R/W | |
| 3 | PE3DR | 0 | R/W | |
| 2 | PE2DR | 0 | R/W | |
| 1 | PE1DR | 0 | R/W | |
| 0 | PE0DR | 0 | R/W | |

Table 18.5 Port E Data Register L (PEDRL) Read/Write Operations

- Bits 15 to 0 in PEDRL

| PEIOR | Pin Function | Read | Write |
|--------------|---------------------------|-------------|---|
| 0 | General input | Pin state | Can write to PEDRL, but it has no effect on pin state |
| | Other than general input | Pin state | Can write to PEDRL, but it has no effect on pin state |
| 1 | General output | PEDRL value | Value written is output from pin |
| | Other than general output | PEDRL value | Can write to PEDRL, but it has no effect on pin state |

18.6 Port F

Port F is an input-only port with the eight pins shown in figure 18.9.

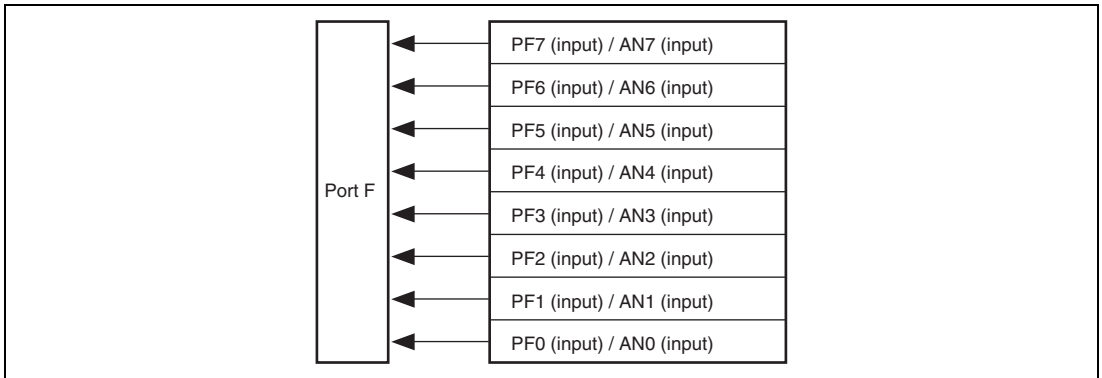

Figure 18.9 Port F

18.6.1 Register Descriptions

Port F is an 8-bit input-only port. Port F has the following register. For details on register addresses and register states during each processing, refer to section 25, List of Registers.

- Port F data register (PFDR)

18.6.2 Port F Data Register (PFDR)

The port F data register (PFDR) is an 8-bit read-only register that stores port F data.

Bits PF7DR to PF0DR correspond to pins PF7 to PF0 (multiplexed functions omitted here).

Any value written into these bits is ignored, and there is no effect on the state of the pins. When any of the bits are read, the pin state rather than the bit value is read directly. However, when an A/D converter analog input is being sampled, values of 1 are read out. Table 18.6 summarizes port F data register read/write operations.

| Bit | Bit Name | Initial Value | R/W | Description |
|-----|----------|---------------|-----|-----------------|
| 7 | PF7DR | 0/1* | R | See table 18.6* |
| 6 | PF6DR | 0/1* | R | |
| 5 | PF5DR | 0/1* | R | |
| 4 | PF4DR | 0/1* | R | |
| 3 | PF3DR | 0/1* | R | |
| 2 | PF2DR | 0/1* | R | |
| 1 | PF1DR | 0/1* | R | |
| 0 | PF0DR | 0/1* | R | |

Notes: * Initial values are dependent on the state of the pins.

Table 18.6 Port F Data Register (PFDR) Read/Write Operations

- Bits 7 to 0

| Pin Function | Read | Write |
|--------------------------|-----------|----------------------------------|
| General input | Pin state | Ignored (no effect on pin state) |
| ANn input (analog input) | 1 | Ignored (no effect on pin state) |

Section 19 Flash Memory (F-ZTAT Version)

The features of the flash memory in the flash memory version are summarized below.

The block diagram of the flash memory is shown in figure 19.1.

19.1 Features

- Size: 256 kbytes
- Programming/erasing methods
 - The flash memory is programmed 128 bytes at a time. Erase is performed in single-block units. The flash memory is configured as follows: 64 kbytes \times 3 blocks, 32 kbytes \times 1 block, and 4 kbytes \times 8 blocks. To erase the entire flash memory, each block must be erased in turn.
- Reprogramming capability
 - See section 26.5, Flash Memory Characteristics.
- Two on-board programming modes
 - Boot mode
 - User program mode
 - On-board programming/erasing can be done in boot mode, in which the boot program built into the chip is started to erase or program of the entire flash memory. In normal user program mode, individual blocks can be erased or programmed.
- PROM programmer mode
 - Flash memory can be programmed/erased in programmer mode using a PROM programmer, as well as in on-board programming mode.
- Automatic bit rate adjustment
 - With data transfer in boot mode, this LSI's bit rate can be automatically adjusted to match the transfer bit rate of the host computer.
- Programming/erasing protection
 - Sets software protection against flash memory programming/erasing/verifying.

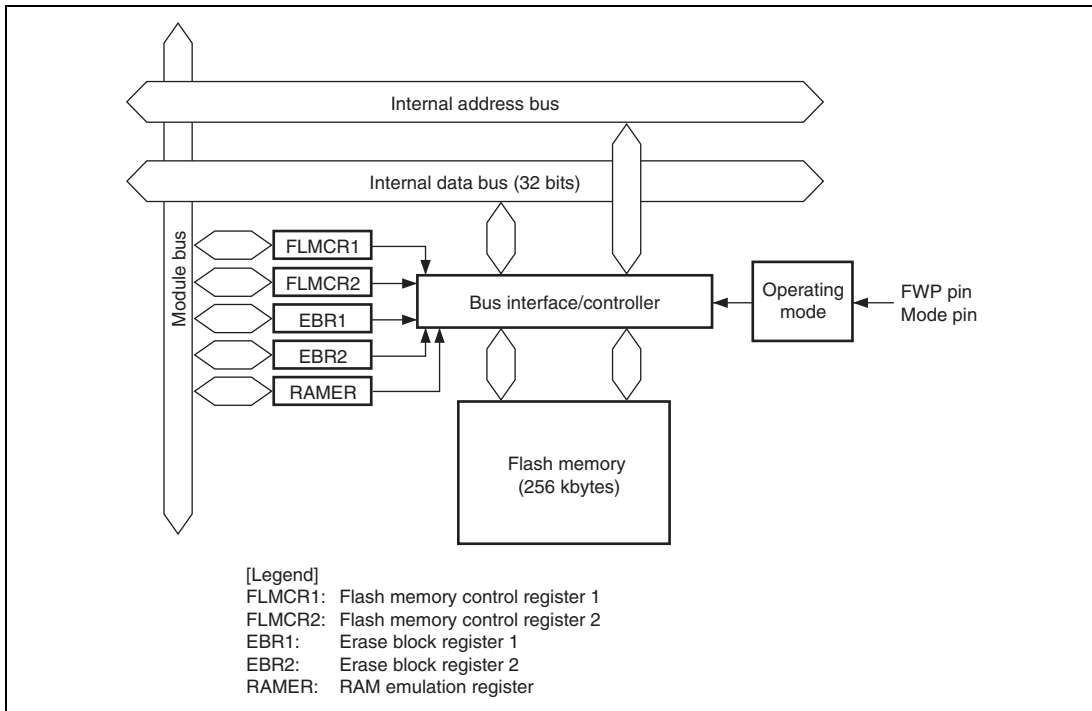

Figure 19.1 Block Diagram of Flash Memory

19.2 Mode Transitions

When the mode pin and the FWP pin are set in the reset state and a reset-start is executed, this LSI enters an operating mode as shown in figure 19.2. In user mode, flash memory can be read but not programmed or erased.

The boot mode, user program mode, and PROM programmer modes are provided as modes to write and erase the flash memory.

The differences between boot mode and user program mode are shown in table 19.1.

Figure 19.3 shows boot mode, and figure 19.4 shows user program mode.

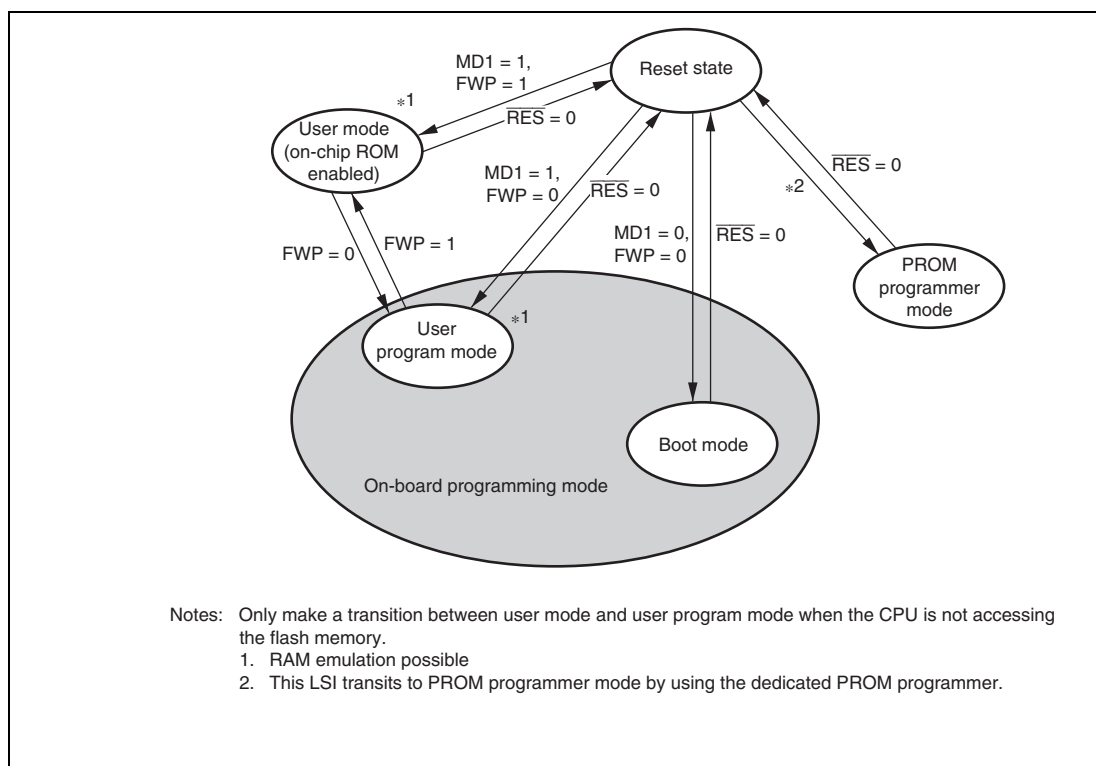

Figure 19.2 Flash Memory State Transitions

Table 19.1 Differences between Boot Mode and User Program Mode

| | Boot Mode | User Program Mode |
|------------------------------|------------------------|---|
| Total erase | Yes | Yes |
| Block erase | No | Yes |
| Programming control program* | Program/program-verify | Erase/erase-verify Program/program-verify Emulation |

Note: * To be provided by the user, in accordance with the recommended algorithm.

1. Initial state

The old program version or data remains written in the flash memory. The user should prepare the programming control program and new application program beforehand in the host.

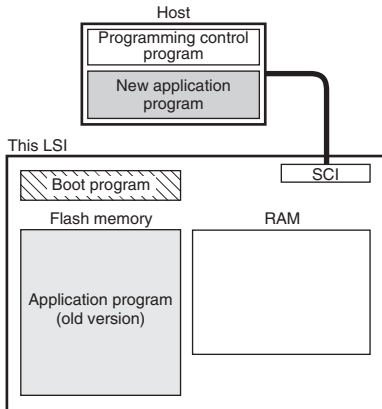

2. Programming control program transfer

When boot mode is entered, the boot program in this LSI (originally incorporated in the chip) is started and the programming control program in the host is transferred to RAM via SCI communication. The boot program required for flash memory erasing is automatically transferred to the RAM boot program area.

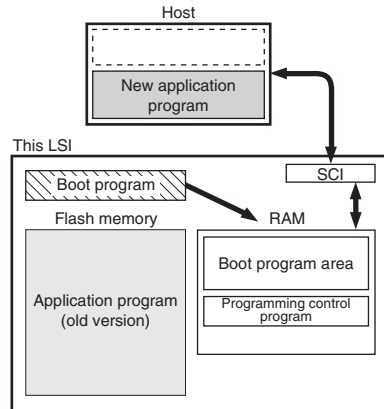

3. Flash memory initialization

The erase program in the boot program area (in RAM) is executed, and the flash memory is initialized (to H'FF). In boot mode, total flash memory erasure is performed, without regard to blocks.

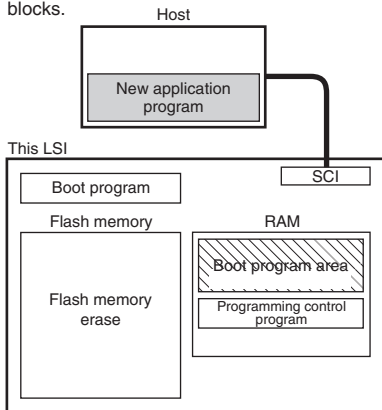

4. Writing new application program

The programming control program transferred from the host to RAM is executed, and the new application program in the host is written into the flash memory.

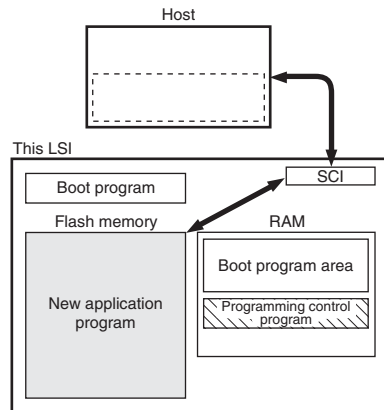

 Program execution state

Figure 19.3 Boot Mode

1. Initial state

The FWE assessment program that confirms that user program mode has been entered, and the program that will transfer the programming/erase control program from flash memory to on-chip RAM should be written into the flash memory by the user beforehand. The programming/erase control program should be prepared in the host or in the flash memory.

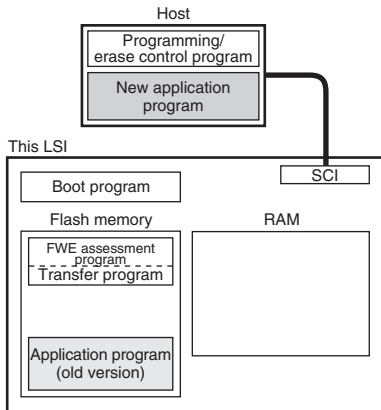

2. Programming/erase control program transfer

When user program mode is entered, user software confirms this fact, executes transfer program in the flash memory, and transfers the programming/erase control program to RAM.

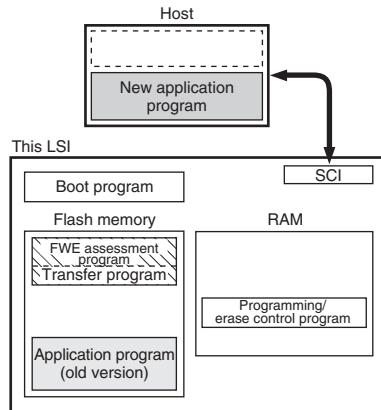

3. Flash memory initialization

The programming/erase program in RAM is executed, and the flash memory is initialized (to H'FF). Erasing can be performed in block units, but not in byte units.

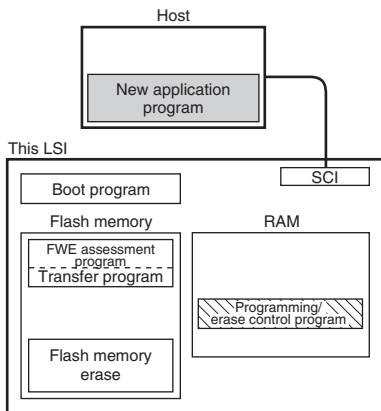

4. Writing new application program

Next, the new application program in the host is written into the erased flash memory blocks. Do not write to unerased blocks.

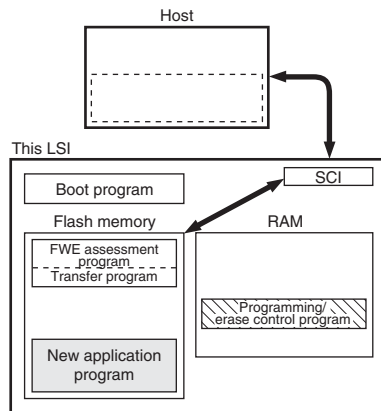

 Program execution state

Figure 19.4 User Program Mode

19.3 Block Configuration

Figure 19.5 shows the block configuration of 256-kbyte flash memory. The thick lines indicate erasing units, the narrow lines indicate programming units, and the values are addresses. The flash memory is divided into 64 kbytes (3 blocks), 32 kbytes (1 block), and 4 kbytes (8 blocks). Erasing is performed in these units. Programming is performed in 128-byte units starting from an address with lower eight bits H'00 or H'80.

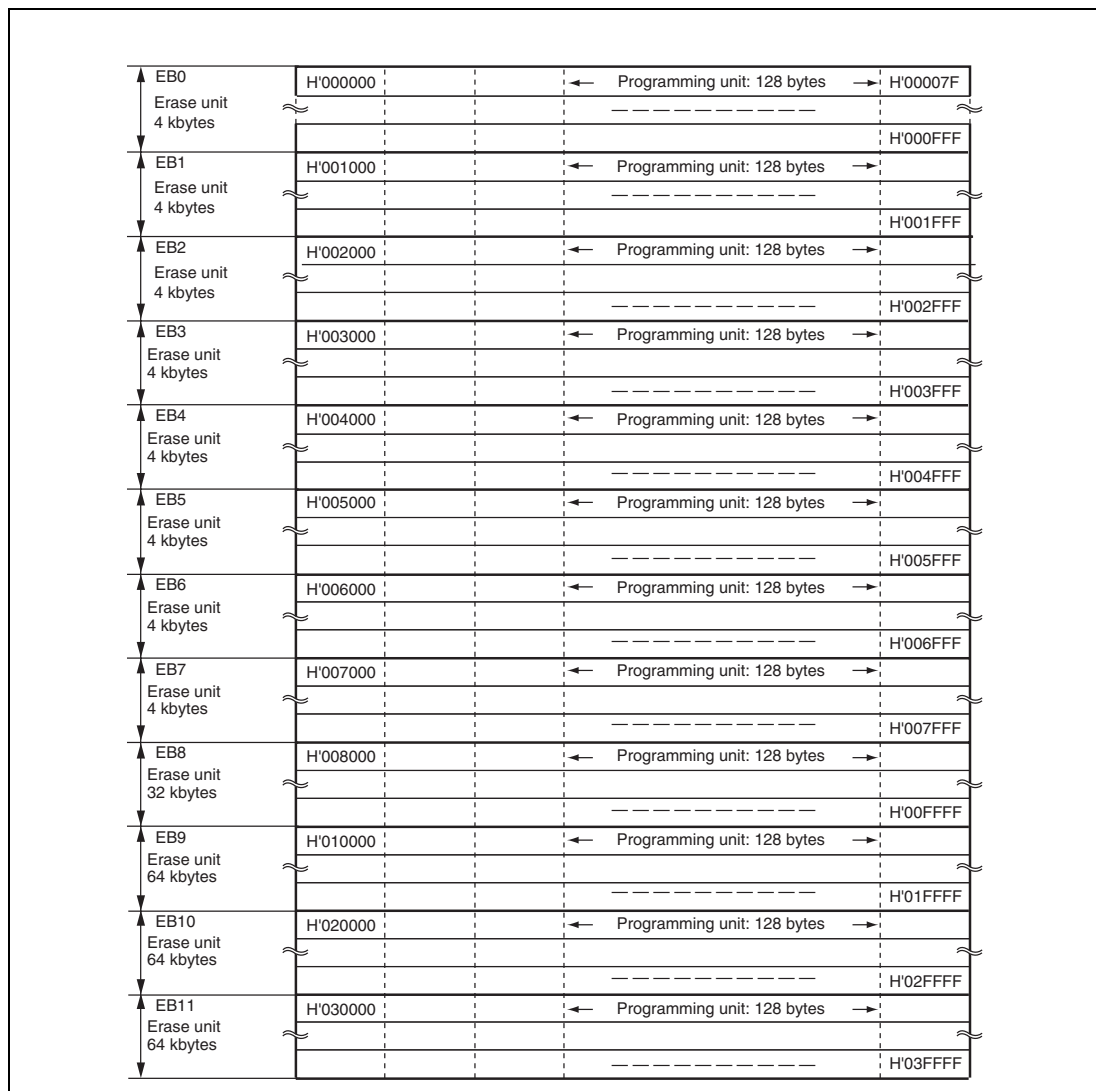

Figure 19.5 Flash Memory Block Configuration

19.4 Input/Output Pins

The flash memory is controlled by means of the pins shown in table 19.2.

Table 19.2 Pin Configuration

| Pin Name | I/O | Function |
|--------------------------|------------|--|
| $\overline{\text{RES}}$ | Input | Reset |
| FWP* ¹ | Input | Flash programming/erasing protection by hardware |
| MD1 | Input | Sets this LSI's operating mode |
| MD0 | Input | Sets this LSI's operating mode |
| TxD1 (PA4)* ² | Output | Serial transmit data output |
| RxD1 (PA3)* ² | Input | Serial receive data input |

- Notes: 1. Protection cannot be made to flash memory programming/erasing regardless of the setting of the FWP pin when using E10A (when DBGMD is high)
2. In boot mode, SCI pins are fixed, and PA3 and PA4 pins are used as SCI pins.

19.5 Register Descriptions

The flash memory has the following registers. For details on register addresses and register states during each processing, refer to section 25, List of Registers.

- Flash memory control register 1 (FLMCR1)
- Flash memory control register 2 (FLMCR2)
- Erase block register 1 (EBR1)
- Erase block register 2 (EBR2)
- RAM emulation register (RAMER)

19.5.1 Flash Memory Control Register 1 (FLMCR1)

FLMCR1 is a register that makes the flash memory change to program mode, program-verify mode, erase mode, or erase-verify mode. For details on register setting, refer to section 19.8, Flash Memory Programming/Erasing.

| Bit | Bit Name | Initial Value | R/W | Description |
|-----|----------|---------------|-----|--|
| 7 | FEW | 1/0 | R | Flash Write Enable* Reflects the input level at the FWP pin. It is set to 1 when a low level is input to the FWP pin, and cleared to 0 when a high level is input. |
| 6 | SWE | 0 | R/W | Software Write Enable When this bit is set to 1 while the FEW bit is 1, flash memory programming/erasing is enabled. When this bit is cleared to 0, other FLMCR1 bits and all EBR1 and EBR2 bits cannot be set. |
| 5 | ESU | 0 | R/W | Erase Setup When this bit is set to 1 while the FEW and SWE bits are 1, the flash memory changes to the erase setup state. When it is cleared to 0, the erase setup state is cancelled. |
| 4 | PSU | 0 | R/W | Program Setup When this bit is set to 1 while the FEW and SWE bits are 1, the flash memory changes to the program setup state. When it is cleared to 0, the program setup state is cancelled. |

19. Flash Memory (F-ZTAT Version)

| Bit | Bit Name | Initial Value | R/W | Description |
|-----|----------|---------------|-----|---|
| 3 | EV | 0 | R/W | Erase-Verify When this bit is set to 1 while the FEW and SWE bits are 1, the flash memory changes to erase-verify mode. When it is cleared to 0, erase-verify mode is cancelled. |
| 2 | PV | 0 | R/W | Program-Verify When this bit is set to 1 while the FEW and SWE bits are 1, the flash memory changes to program-verify mode. When it is cleared to 0, program-verify mode is cancelled. |
| 1 | E | 0 | R/W | Erase When this bit is set to 1 while the FEW, SWE and ESU bits are 1, the flash memory changes to erase mode. When it is cleared to 0, erase mode is cancelled. |
| 0 | P | 0 | R/W | Program When this bit is set to 1 while the FEW, SWE and PSU bits are 1, the flash memory changes to program mode. When it is cleared to 0, program mode is cancelled. |

Note: * The value of this bit is 1 when using E10A (when DBGMD is high).

19.5.2 Flash Memory Control Register 2 (FLMCR2)

FLMCR2 is a register that displays the state of flash memory programming/erasing.

| Bit | Bit Name | Initial Value | R/W | Description |
|--------|----------|---------------|-----|--|
| 7 | FLER | 0 | R | Indicates that an error has occurred during an operation on flash memory (programming or erasing). When FLER is set to 1, flash memory goes to the error-protection state. See section 19.9.3, Error Protection, for details. |
| 6 to 0 | — | All 0 | R | Reserved These bits are always read as 0. |

19.5.3 Erase Block Register 1 (EBR1)

EBR1 specifies the flash memory erase block. EBR1 is initialized to H'00 when a high level is input to the FWP pin. It is also initialized to H'00, when the SWE bit in FLMCR1 is 0 regardless of value in the FWP pin. Do not set more than one bit at a time in EBR1 and EBR2, as this will cause all the bits in EBR1 and EBR2 to be automatically cleared to 0.

| Bit | Bit Name | Initial Value | R/W | Description |
|-----|----------|---------------|-----|---|
| 7 | EB7 | 0 | R/W | When this bit is set to 1, 4 kbytes of EB7 (H'007000 to H'007FFF) are to be erased. |
| 6 | EB6 | 0 | R/W | When this bit is set to 1, 4 kbytes of EB6 (H'006000 to H'006FFF) are to be erased. |
| 5 | EB5 | 0 | R/W | When this bit is set to 1, 4 kbytes of EB5 (H'005000 to H'005FFF) are to be erased. |
| 4 | EB4 | 0 | R/W | When this bit is set to 1, 4 kbytes of EB4 (H'004000 to H'004FFF) are to be erased. |
| 3 | EB3 | 0 | R/W | When this bit is set to 1, 4 kbytes of EB3 (H'003000 to H'003FFF) are to be erased. |
| 2 | EB2 | 0 | R/W | When this bit is set to 1, 4 kbytes of EB2 (H'002000 to H'002FFF) are to be erased. |
| 1 | EB1 | 0 | R/W | When this bit is set to 1, 4 kbytes of EB1 (H'001000 to H'001FFF) are to be erased. |
| 0 | EB0 | 0 | R/W | When this bit is set to 1, 4 kbytes of EB0 (H'000000 to H'000FFF) are to be erased. |

19.5.4 Erase Block Register 2 (EBR2)

EBR2 specifies the flash memory erase block. EBR2 is initialized to H'00 when a high level is input to the FWP pin. It is also initialized to H'00, when the SWE bit in FLMCR1 is 0 regardless of value in the FWP pin. Do not set more than one bit at a time in EBR1 and EBR2, as this will cause all the bits in EBR1 and EBR2 to be automatically cleared to 0.

| Bit | Bit Name | Initial Value | R/W | Description |
|--------|----------|---------------|-----|---|
| 7 to 4 | — | All 0 | R | Reserved These bits are always read as 0. The write value should always be 0. |
| 3 | EB11 | 0 | R/W | When this bit is set to 1, 64 kbytes of EB11 (H'030000 to H'03FFFF) are to be erased. |
| 2 | EB10 | 0 | R/W | When this bit is set to 1, 64 kbytes of EB10 (H'020000 to H'02FFFF) are to be erased. |
| 1 | EB9 | 0 | R/W | When this bit is set to 1, 64 kbytes of EB9 (H'010000 to H'01FFFF) will be erased. |
| 0 | EB8 | 0 | R/W | When this bit is set to 1, 32 kbytes of EB8 (H'008000 to H'00FFFF) will be erased. |

19.5.5 RAM Emulation Register (RAMER)

RAMER specifies the area of flash memory to be overlapped with part of RAM when emulating real-time flash memory programming. RAMER settings should be made in user mode or user program mode. To ensure correct operation of the emulation function, the ROM for which RAM emulation is performed should not be accessed immediately after this register has been modified. Normal execution of an access immediately after register modification is not guaranteed.

| Bit | Bit Name | Initial Value | R/W | Description |
|---------|----------|---------------|-----|--|
| 15 to 4 | — | All 0 | R | Reserved These bits are always read as 0. The write value should always be 0. |
| 3 | RAMS | 0 | R/W | RAM Select Specifies selection or non-selection of flash memory emulation in RAM. When RAMS = 1, the flash memory is overlapped with part of RAM, and all flash memory blocks are program/erase-protected. When RAMS = 0, the RAM emulation function is disabled. |

| Bit | Bit Name | Initial Value | R/W | Description |
|-----|----------|---------------|-----|--|
| 2 | RAM2 | 0 | R/W | Flash Memory Area Selection |
| 1 | RAM1 | 0 | R/W | When the RAMS bit is set to 1, these bits specify one of the following flash memory areas to be overlapped with part of RAM. 000: H'00000000 to H'00000FFF (EB0) 001: H'00001000 to H'00001FFF (EB1) 010: H'00002000 to H'00002FFF (EB2) 011: H'00003000 to H'00003FFF (EB3) 100: H'00004000 to H'00004FFF (EB4) 101: H'00005000 to H'00005FFF (EB5) 110: H'00006000 to H'00006FFF (EB6) 111: H'00007000 to H'00007FFF (EB7) |
| 0 | RAM0 | 0 | R/W | |

19.6 On-Board Programming Modes

There are two modes for programming/erasing of the flash memory; boot mode, which enables on-board programming/erasing, and PROM programmer mode, in which programming/erasing is performed with a PROM programmer. On-board programming/erasing can also be performed in user program mode. At reset-start in reset mode, this LSI changes to a mode depending on the MD pin settings and FWP pin setting, as shown in table 19.3.

When changing to boot mode, the boot program built into this LSI is initiated. The boot program transfers the programming control program from the externally-connected host to on-chip RAM via SCI1. After erasing the entire flash memory, the programming control program is executed. This can be used for programming initial values in the on-board state or for a forcible return when programming/erasing can no longer be done in user program mode. In user program mode, individual blocks can be erased and programmed by branching to the user program/erase control program prepared by the user.

Table 19.3 Setting On-Board Programming Modes

| MD1 | MD0 | FWP | LSI State after Reset End | |
|-----|-----|-----|---------------------------|------------------|
| 0 | 0 | 0 | Boot mode | Expanded mode |
| | 1 | | | Single-chip mode |
| 1 | 0 | | User program mode | Expanded mode |
| | 1 | | | Single-chip mode |

19.6.1 Boot Mode

Table 19.4 shows the boot mode operations between reset end and branching to the programming control program.

1. When boot mode is used, the flash memory programming control program must be prepared in the host beforehand. Prepare a programming control program in accordance with the description in section 19.8, Flash Memory Programming/Erasing.
2. The SCI1 should be set to asynchronous mode, and the transfer format as follows: 8-bit data, 1 stop bit, and no parity.
3. When the boot program is initiated, the chip measures the low-level period of asynchronous SCI communication data (H'00) transmitted continuously from the host. The chip then calculates the bit rate of transmission from the host, and adjusts the SCI1 bit rate to match that of the host. The reset should end with the RxD pin high. The RxD and TxD pins should be pulled up on the board if necessary.
4. After matching the bit rates, the chip transmits one H'00 byte to the host to indicate the completion of bit rate adjustment. The host should confirm that this adjustment end indication (H'00) has been received normally, and transmit one H'55 byte to the chip. If reception could not be performed normally, initiate boot mode again by a reset. Depending on the host's transfer bit rate and system clock frequency of this LSI, there will be a discrepancy between the bit rates of the host and the chip. To operate the SCI properly, set the host's transfer bit rate and system clock frequency of this LSI within the ranges listed in table 19.5.
5. In boot mode, a part of the on-chip RAM area is used by the boot program. The area H'FFF800 to H'FFFFFFF is the area to which the programming control program is transferred from the host. The boot program area cannot be used until the execution state in boot mode switches to the programming control program.
6. Before branching to the programming control program, the chip terminates transfer operations by SCI1 (by clearing the RE and TE bits in SCR to 0), however the adjusted bit rate value remains set in BRR. Therefore, the programming control program can still use it for transfer of write data or verify data with the host. The TxD pin is high. The contents of the CPU general registers are undefined immediately after branching to the programming control program. These registers must be initialized at the beginning of the programming control program, as the stack pointer (SP), in particular, is used implicitly in subroutine calls, etc.
7. Boot mode can be cleared by a reset. End the reset after driving the reset pin low, waiting at least 25 states, and then setting the mode (MD) pins. Boot mode is also cleared when a WDT overflow occurs.
8. Do not change the MD pin input levels in boot mode.
9. All interrupts are disabled during programming or erasing of the flash memory.

Table 19.4 Boot Mode Operation

| Item | Host Operation | Communications Contents | LSI Operation |
|---|--|---|--|
| | Processing Contents | | Processing Contents |
| Boot mode start | | | Branches to boot program at reset-start. <div style="text-align: center;">  </div> |
| Bit rate adjustment | Continuously transmits data H'00 at specified bit rate. ↓ Transmits data H'55 when data H'00 is received error-free. ↓ Receives data H'AA. | H'00, H'00 H'00 → ← H'00 → H'55 ← H'AA | <ul style="list-style-type: none"> Measures low-level period of receive data H'00. Calculates bit rate and sets it in BRR of SCI_1. Transmits data H'00 to host as adjustment end indication. ↓ Transmits data H'AA to host when data H'55 is received. |
| Transfer of programming control program | Transmits number of bytes (N) of programming control as program to be transferred 2-byte data (lower byte following upper byte) ↓ Transmits 1-byte of programming control program (repeated for N times) | → Upper byte and lower byte ← Echoback → H'XX ← Echoback | Echobacks the 2-byte data received. ↓ Echobacks received data to host and also transfers it to RAM (repeated for N times) |
| Flash memory erase | ↓ Receives data H'AA. | ← H'FF ← H'AA | Checks flash memory data, erases all flash memory blocks in case of written data existing, and transmits data H'AA to host. (If erase could not be done, transmits data H'FF to host and aborts operation.) ↓ Branches to programming control program transferred to on-chip RAM and starts execution. |

Table 19.5 Peripheral Clock (P ϕ) Frequencies for which Automatic Adjustment of LSI Bit Rate Is Possible

| Host Bit Rate | Peripheral Clock Frequency Range of LSI |
|---------------|---|
| 9,600 bps | 4 to 40 MHz |
| 19,200 bps | 8 to 40 MHz |

19.6.2 Programming/Erasing in User Program Mode

On-board programming/erasing of an individual flash memory block can also be performed in user program mode by branching to a user program/erase control program. The user must set branching conditions and provide on-board means of supplying programming data. The flash memory must contain the user program/erase control program or a program that provides the user program/erase control program from external memory. As the flash memory itself cannot be read during programming/erasing, transfer the user program/erase control program to on-chip RAM or external memory, and execute it. Figure 19.6 shows a sample procedure for programming/erasing in user program mode. Prepare a user program/erase control program in accordance with the description in section 19.8, Flash Memory Programming/Erasing.

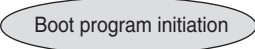
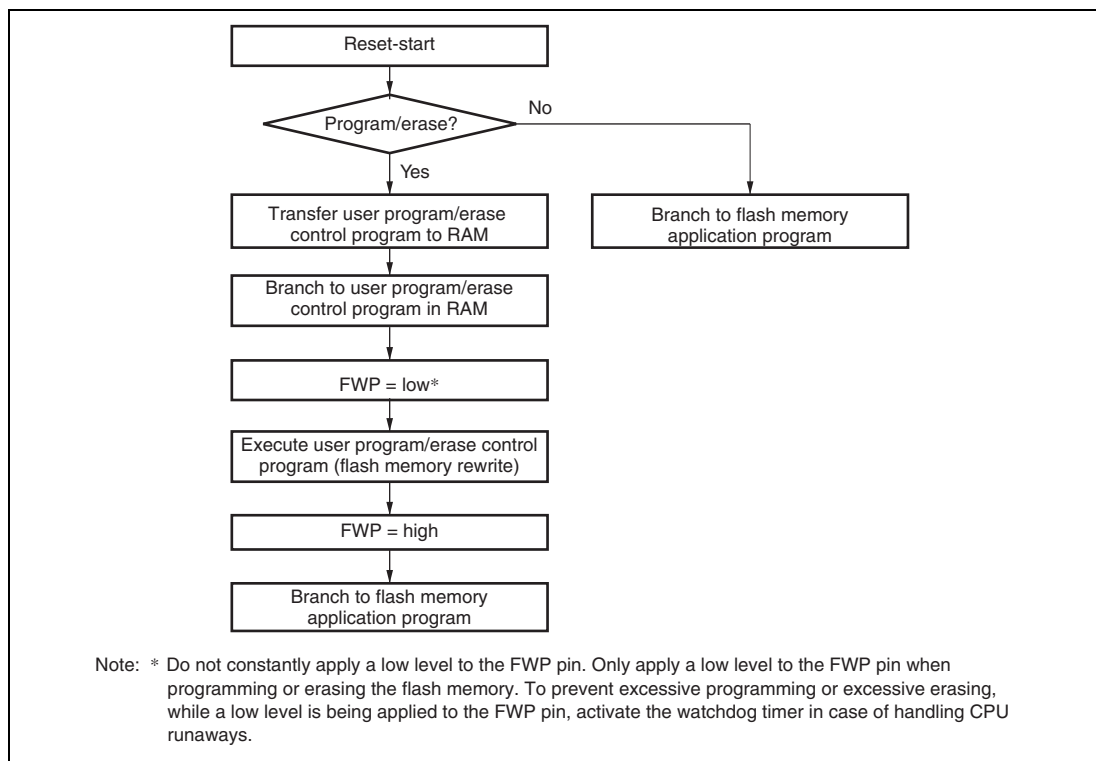

Figure 19.6 Programming/Erasing Flowchart Example in User Program Mode

19.7 Flash Memory Emulation in RAM

A setting in the RAM emulation register (RAMER) enables part of RAM to overlap with the flash memory area so that data to be written to flash memory can be emulated in RAM in real time. Emulation can be performed in user mode or user program mode. Figure 19.7 shows an example of emulation of real-time flash memory programming.

1. Set RAMER to overlap part of RAM with the area for which real-time programming is required.
2. Emulation is performed using the overlapped RAM.
3. After the program data has been confirmed, the RAMS bit is cleared, thus releasing the RAM overlap.
4. The data written in the overlapped RAM is written into the flash memory area.

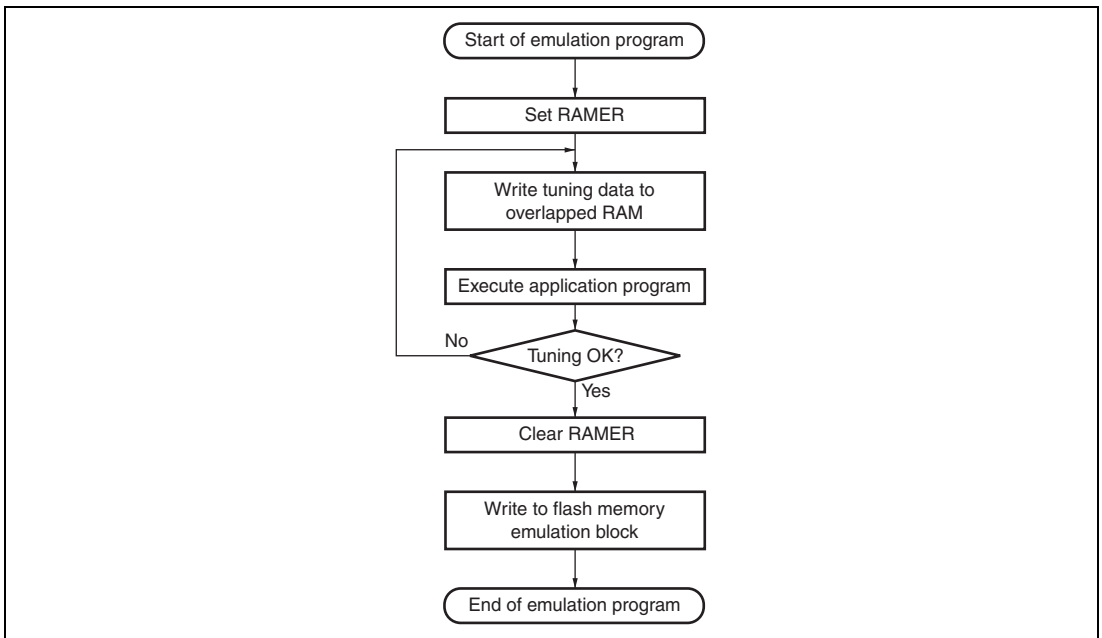

Figure 19.7 Flowchart for Flash Memory Emulation in RAM

Figure 19.8 shows a sample procedure for flash memory block area overlapping.

1. The RAM area to be overlapped is fixed at a 4-kbyte area in the range H'FFFE000 to H'FFFEFFF.
2. The flash memory area to be overlapped is selected by RAMER from a 4-kbyte area of the EB0 to EB7 blocks.
3. The overlapped RAM area can be accessed from both the flash memory addresses and RAM addresses.
4. When the RAMS bit in RAMER is set to 1, program/erase protection is enabled for all flash memory blocks (emulation protection). In this state, setting the P or E bit in FLMCR1 to 1 does not cause a transition to program mode or erase mode.
5. A RAM area cannot be erased by execution of software in accordance with the erase algorithm.
6. Block area EB0 contains the vector table. When performing RAM emulation, the vector table is needed in the overlapped RAM.

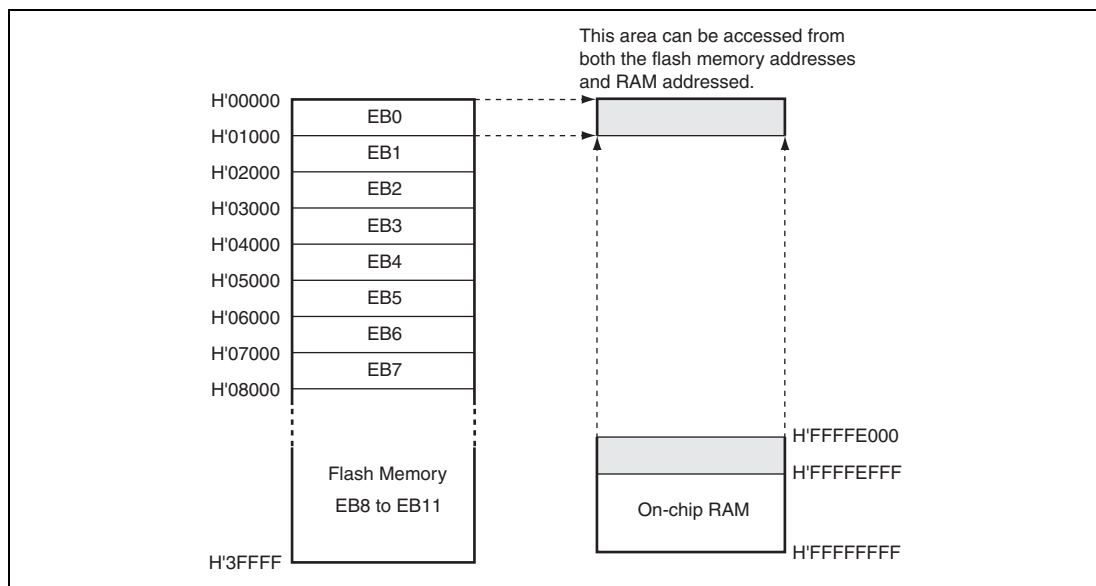

Figure 19.8 Example of RAM Overlap Operation (RAM[2:0] = B'000)

19.8 Flash Memory Programming/Erasing

A software method using the CPU is employed to program and erase the flash memory in on-board programming modes. Depending on the FLMCR1 and FLMCR2 settings, the flash memory operates in one of the following four modes: Program mode, program-verify mode, erase mode, and erase-verify mode. The programming control program in boot mode and the user program/erase control program in user program mode use these operating modes in combination to perform programming/erasing. Flash memory programming and erasing should be performed in accordance with the descriptions in section 19.8.1, Program/Program-Verify Mode and section 19.8.2, Erase/Erase-Verify Mode, respectively.

19.8.1 Program/Program-Verify Mode

When writing data or programs to the flash memory, the program/program-verify flowchart shown in figure 19.9 should be followed. Performing programming operations according to this flowchart will enable data or programs to be written to the flash memory without subjecting the chip to voltage stress or sacrificing program data reliability.

1. Programming must be done to an empty address. Do not reprogram an address to which programming has already been performed.
2. Programming should be carried out 128 bytes at a time. A 128-byte data transfer must be performed even if writing fewer than 128 bytes. In this case, H'FF data must be written to the extra addresses.
3. Prepare the following data storage areas in RAM: A 128-byte programming data area, a 128-byte reprogramming data area, and a 128-byte additional-programming data area. Perform reprogramming data computation and additional programming data computation according to figure 19.9.
4. Consecutively transfer 128 bytes of data in byte units from the reprogramming data area or additional-programming data area to the flash memory. The program address and 128-byte data are latched in the flash memory. The lower 8 bits of the start address in the flash memory destination area must be H'00 or H'80.
5. The time during which the P bit is set to 1 is the programming time. Figure 19.9 shows the allowable programming time.
6. The watchdog timer (WDT) is set to prevent overprogramming due to program runaway, etc. An overflow cycle of approximately 6.6 ms is allowed.
7. For a dummy write to a verify address, write 1-byte data H'FF to an address to be read. Verify data can be read in longwords from the address to which a dummy write was performed.
8. The number of repetitions of the program/program-verify sequence to the same bit should not exceed the maximum number of programming (N).

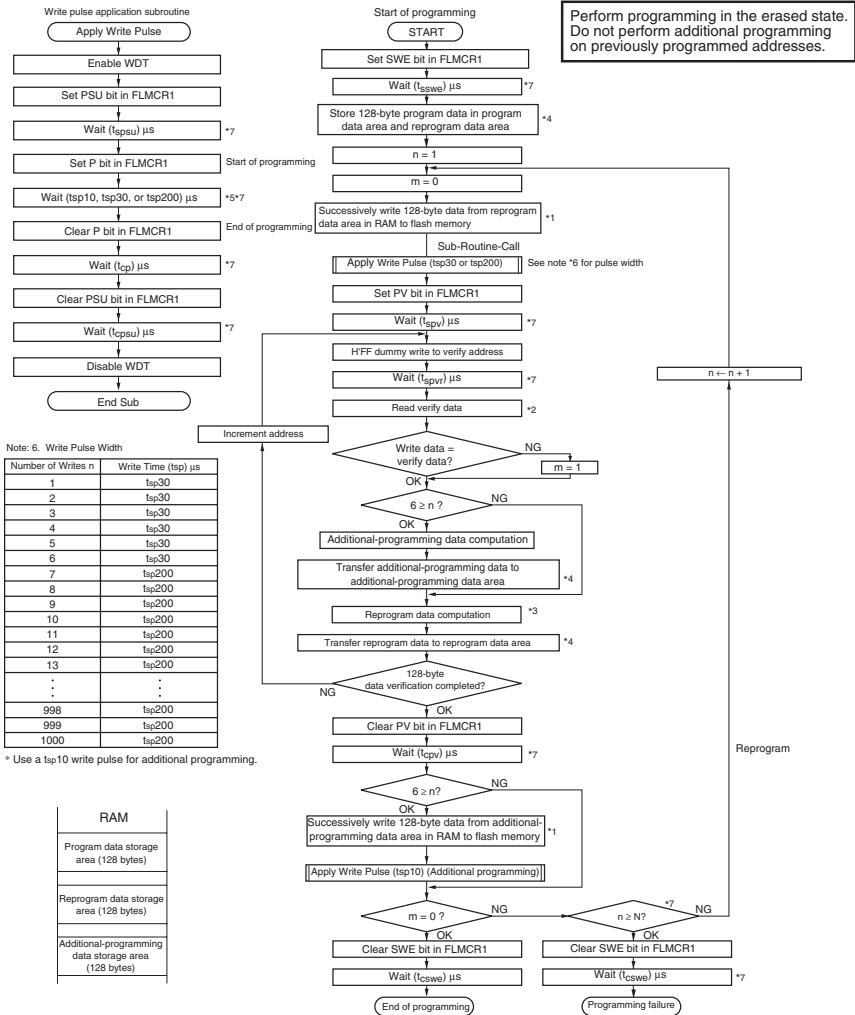

- Notes: 1. Data transfer is performed by byte transfer. The lower 8 bits of the start address to be written to must be H00 or H00. A 128-byte data transfer must be performed even if writing fewer than 128 bytes; in this case, HFF data must be written to the extra addresses.
 2. Verify data is read in 32-bit (longword) units.
 3. Reprogram data is determined by the operation shown in the table below (comparison between the data stored in the program data area and the verify data). Bits for which the reprogram data is 0 are programmed in the next programming loop. Therefore, even bits for which programming has been completed will be subjected to programming once again if the subsequent verify operation ends in failure.
 4. A 128-byte area for the storage of programming data, a 128-byte area for the storage of reprogramming data, and a 128-byte area for the storage of additional-programming data must be provided in RAM. The contents of the reprogram data area and additional-program data area are modified as programming proceeds.
 5. A write pulse of 30 μ s or 200 μ s is applied according to the progress of the programming operation. See note 6 for details of the pulse widths. When writing of additional-programming data is executed, a 10 μ s write pulse should be applied. Reprogram data 'X' means reprogram data when the write pulse is applied.
 7. The wait times and value of N are shown in section 26.5, Flash Memory Characteristics.

| Reprogram Data Computation Table | | | | Additional-Programming Data Computation Table | | | |
|----------------------------------|-----------------|--------------------|-----------------------------------|---|-----------------|---------------------------------|---|
| Original Data (D) | Verify Data (V) | Reprogram Data (X) | Comments | Reprogram Data (X) | Verify Data (V) | Additional-Programming Data (Y) | Comments |
| 0 | 0 | 1 | Programming completed | 0 | 0 | 0 | Additional programming to be executed |
| 0 | 1 | 0 | Programming incomplete; reprogram | 0 | 1 | 1 | Additional programming not to be executed |
| 1 | 0 | 1 | | 1 | 0 | 1 | Additional programming not to be executed |
| 1 | 1 | 1 | Still in erased state; no action | 1 | 1 | 1 | Additional programming not to be executed |

Figure 19.9 Program/Program-Verify Flowchart

19.8.2 Erase/Erase-Verify Mode

When erasing flash memory, the erase/erase-verify flowchart shown in figure 19.10 should be followed.

1. Prewriting (setting erase block data to all 0s) is not necessary.
2. Erasing is performed in block units. Make only a single-bit specification in the erase block register 1 (EBR1) and the erase block register 2 (EBR2). To erase multiple blocks, each block must be erased in turn.
3. The time during which the E bit is set to 1 is the flash memory erase time.
4. The watchdog timer (WDT) is set to prevent overerasing due to program runaway, etc. An overflow cycle of approximately 19.8 ms is allowed.
5. For a dummy write to a verify address, write 1-byte data H'FF to the read address. Verify data can be read in longwords from the address to which a dummy write was performed.
6. If the read data is not erased successfully, set erase mode again, and repeat the erase/erase-verify sequence as before. The number of repetitions of the erase/erase-verify sequence should not exceed the maximum number of erasing (N).

19.8.3 Interrupt Handling when Programming/Erasing Flash Memory

All interrupts, including the NMI interrupt, are disabled while flash memory is being programmed or erased, or while the boot program is executing, for the following three reasons:

1. An interrupt during programming/erasing may cause a violation of the programming or erasing algorithm, with the result that normal operation cannot be assured.
2. If an interrupt exception handling starts before the vector address is written or during programming/erasing, a correct vector cannot be fetched and the CPU malfunctions.
3. If an interrupt occurs during boot program execution, normal boot mode sequence cannot be carried out.

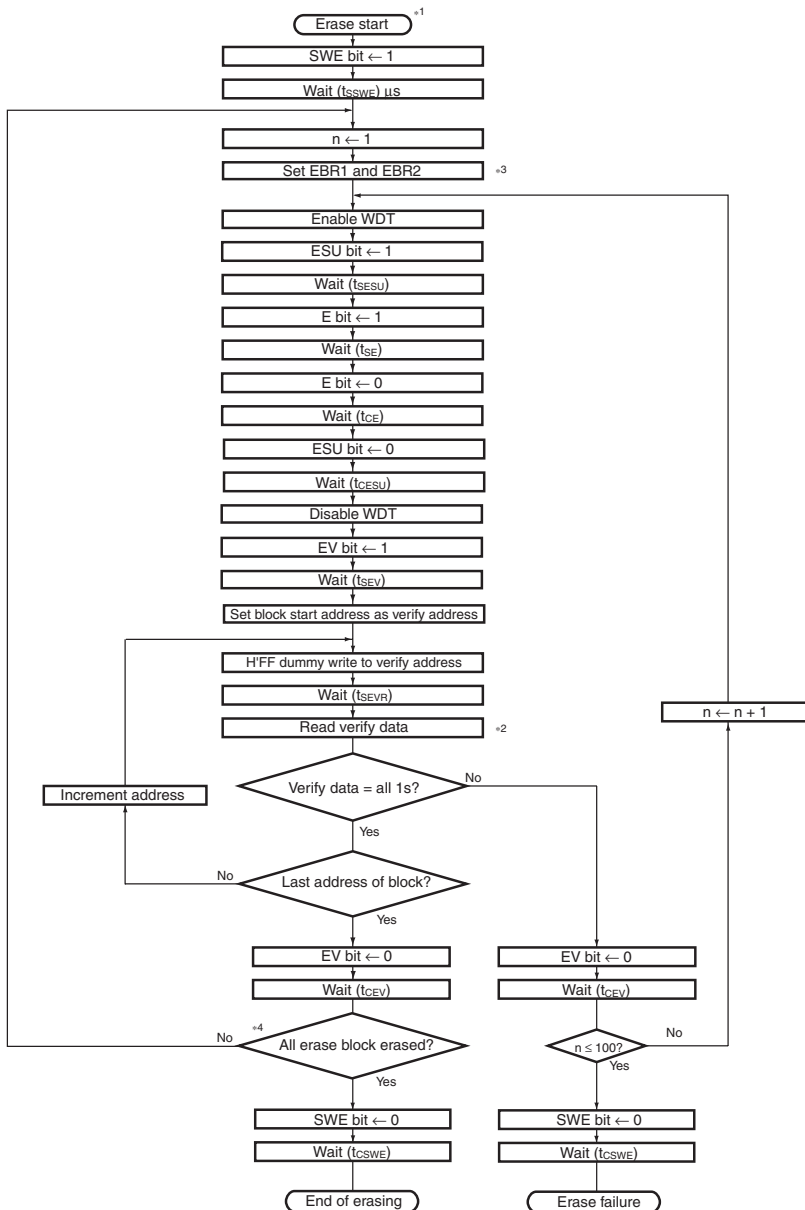

- Notes:
1. Prewriting (setting erase block data to all 0s) is not necessary.
 2. Verify data is read in 32-bit (longword) units.
 3. Make only a single-bit specification in the erase block register 1 (EBR1) and the erase block register 2 (EBR2).
 4. Erasing is performed in block units. To erase multiple blocks, each block must be erased in turn.

Figure 19.10 Erase/Erase-Verify Flowchart

19.9 Program/Erase Protection

There are three kinds of flash memory program/erase protection; hardware protection, software protection, and error protection.

19.9.1 Hardware Protection

Hardware protection refers to a state in which programming/erasing of flash memory is forcibly disabled or aborted. Flash memory control register 1 (FLMCR1), flash memory control register 2 (FLMCR2), erase block register 1 (EBR1), and erase block register 2 (EBR2) are initialized.

| Item | Description | Protect Function | |
|-----------------------|--|------------------|-------|
| | | Program | Erase |
| FWP pin protect | When a high level is input to the FWP pin, FLMCR1, EBR 1, and EBR 2 are initialized, and the program/erase protection state is entered.* | Yes | Yes |
| Reset/standby protect | In the reset state (including the reset state when the WDT overflows) and standby mode, FLMCR1, EBR 1, and EBR 2 are initialized, and the program/erase protection state is entered. In a reset via the $\overline{\text{RES}}$ pin, the reset state is not entered unless the $\overline{\text{RES}}$ pin is held low until oscillation stabilizes after powering on. In the case of a reset during operation, hold the $\overline{\text{RES}}$ pin low for the $\overline{\text{RES}}$ pulse width specified in the AC Characteristics section. | Yes | Yes |

Note: * Protection by the FWP pin cannot be made when using E10A (when DBGMD is high).

19.9.2 Software Protection

Software protection can be implemented against programming/erasing of all flash memory blocks by clearing the SWE bit in FLMCR1. When software protection is in effect, setting the P or E bit in FLMCR1 does not cause a transition to program mode or erase mode. By setting the erase block register 1 (EBR1), erase protection can be set for individual blocks. When EBR1 is set to H'00, erase protection is set for all blocks.

| Item | Description | Protect Function | |
|-------------------|--|------------------|-------|
| | | Program | Erase |
| SWE bit protect | When the SWE bit in FLMCR1 is cleared to 0, all blocks are program/erase-protected. (This setting should be carried out in on-chip RAM or external memory.) | Yes | Yes |
| Block protect | By setting the erase block register 1 (EBR1) and the erase block register 2 (EBR2), erase protection can be set for individual blocks. When both EBR1 and EBR2 are set to H'00, erase protection is set for all blocks. | — | Yes |
| Emulation protect | When the RAMS bit in RAMER is set to 1, all blocks are program/erase-protected. | Yes | Yes |

19.9.3 Error Protection

In error protection, an error is detected when CPU runaway occurs during flash memory programming/erasing, or operation is not performed in accordance with the program/erase algorithm, and the program/erase operation is forcibly aborted. Aborting the program/erase operation prevents damage to the flash memory due to overprogramming or overerasing.

When the following errors are detected during programming/erasing of flash memory, the FLER bit in FLMCR2 is set to 1, and the error protection state is entered.

- When the flash memory is read during programming/erasing (including vector read and instruction fetch)
- Immediately after exception handling (excluding a reset) during programming/erasing
- When a SLEEP instruction is executed during programming/erasing

The FLMCR1, FLMCR2, EBR1, and EBR2 settings are retained, however program mode or erase mode is forcibly aborted at the point when the error is detected. Program mode or erase mode cannot be re-entered by re-setting the P1 or E1 bit. However, PV and EV bit settings are retained,

and a transition can be made to verify mode. The error protection state can be cancelled by the power-on reset only.

19.10 PROM Programmer Mode

In PROM programmer mode, a PROM programmer can be used to perform programming/erasing via a socket adapter, just as for a discrete flash memory. Use a PROM programmer that supports the Renesas 256-kbyte flash memory on-chip MCU device type (FZTAT256V3A).

19.11 Usage Note

19.11.1 Module Standby Mode Setting

Access to flash memory can be enabled/disabled by the module standby control register (MSTCR1). The initial value enables access to flash memory. Flash memory access is disabled by setting the module standby control register. For details, see section 24, Power-Down Modes.

19.11.2 Notes when Converting the F-ZTAT Versions to the Masked-ROM Versions

Please note the following when converting the F-ZTAT versions to the masked-ROM versions, with using the F-ZTAT application software.

In the masked-ROM version, addresses of the flash memory registers (refer to section 25.1, Register Addresses Table (In the Order from Lower Addresses)) return undefined value if read.

When the F-ZTAT application software is used in the masked-ROM version, the FWP pin level cannot be determined. When converting the program, make sure the reprogramming (erasing/programming) part of the flash memory and the RAM emulation part not to be initiated.

In the masked-ROM version, boot mode pin setting should not be performed.

Note: This difference applies to all the F-ZTAT versions and all the masked-ROM versions that have different ROM size.

19.11.3 Notes on Flash Memory Programming and Erasing

Precautions concerning the use of on-board programming mode, the RAM emulation function, and programmer mode are summarized below.

Use the specified voltages and timing for programming and erasing: Applying excessive voltage beyond the specification can permanently damage the device. Use an EPROM programmer that supports the Renesas' microcomputer device having on-chip 256-kbyte flash memory. Use only the specified socket adapter, otherwise a serious damage may occur.

Powering on and off (see figures 19.11 to 19.13): Do not apply a low level to the FWP pin until V_{cc} has been stabilized. Also, drive the FWP pin high before turning off V_{cc} . If V_{cc} is to be applied or disconnected, fix the FWP pin level at V_{cc} and place the flash memory in the hardware protection state in advance.

Conditions for this power-on and power-off timing should also be applied in the event of a power failure and subsequent recovery.

FWP application/disconnection (see figures 19.11 to 19.13): If V_{cc} is on or off while low level is applied to FWP pin, a voltage surge from low level on the RESET pin may cause unintentional programming or erasing of flash memory. Applying voltage to FWP should be carried out while MCU operation is in a stable condition. If MCU operation is not stable, fix the FWP pin high and set the protection state. The following points must be observed concerning FWP application and disconnection to prevent unintentional programming or erasing of flash memory:

- Apply voltage to FWP while the V_{cc} voltage is stable enough to satisfy the specification voltage range.
- In boot mode, apply voltage to FWP or disconnect it during a reset.
- Prior to applying voltage while FWP pin is in low level in boot mode, ensure that the RESET pin level is surely kept low despite the applying voltage is rising to V_{cc} . Note that in a case where ICs for reset are used, the voltage level of RESET pin can transiently exceed $1/2 V_{cc}$ while V_{cc} is rising.
- In user program mode, FWP can be switched between high and low level regardless of the reset state. FWP input can also be switched during execution of a program in flash memory.
- Apply voltage to FWP while programs are not running away.
- Disconnect FWP only when the SWE, ESU, PSU, EV, PV, P, and E bits in FLMCR1 are cleared. Make sure that the SWE, ESU, PSU, EV, PV, P, and E bits are not set by mistake when applying voltage to FWP pin or disconnecting.

Do not apply a constant low level to the FWP pin: If a program runs away while low level is applied to FWP pin, incorrect programming or erasing may occur. Apply a low level to the FWP

pin only when programming or erasing flash memory. Avoid creating a system configuration in which a low level is constantly applied to the FWP pin. Also, while a low level is applied to the FWP pin, the watchdog timer should be activated to prevent excess programming or excess erasing due to program runaway, etc.

Use the recommended algorithm when programming and erasing flash memory: The recommended algorithm enables programming and erasing to be carried out without subjecting the device to voltage stress or sacrificing program data reliability. When setting the P or E bit in FLMCR1, the watchdog timer should be set beforehand as a precaution against program runaway, etc.

Do not set or clear the SWE bit during execution of a program in flash memory: Wait for at least 100 μ s after clearing the SWE bit before executing a program or reading data in flash memory. When the SWE bit is set, data in flash memory can be rewritten. Access flash memory only for verify operations (verification during programming/erasing). Also, do not clear the SWE bit during programming, erasing, or verifying. Similarly, when using the RAM emulation function while a low level is being input to the FWP pin, the SWE bit must be cleared before executing a program or reading data in flash memory. However, the RAM area overlapping flash memory space can be read and written to regardless of whether the SWE bit is set or cleared.

Do not use interrupts while flash memory is being programmed or erased: All interrupt requests, including NMI, should be disabled during FWP application to give priority to program/erase operations.

Do not perform additional programming. Erase the memory before reprogramming: In on-board programming, perform only one programming operation on a 128-byte programming unit block. In programmer mode, too, perform only one programming operation on a 128-byte programming unit block. Programming should be carried out with the entire programming unit block erased.

Before programming, check that the chip is correctly mounted in the EPROM programmer: Overcurrent damage to the device can result if the index marks on the EPROM programmer socket, socket adapter, and chip are not correctly aligned.

Do not touch the socket adapter or chip during programming: Casual contact with either of these by hand or something while programming can generate a transient noise on the FWP and RESET pins or cause incorrect programming or erasing due to bad electrical contact.

Reset the flash memory before turning on the power: If V_{cc} is applied to the RESET pin while in high state, mode signals are not correctly downloaded, causing MCU's runaway. In a case where FWP pin is in low state, incorrect programming or erasing can occur.

Apply the reset signal while SWE is low to reset the flash memory during its operation: The reset signal is applied at least 100 μs after the SWE bit has been cleared.

Comply with power-on procedure designated by the programmer maker: When executing an on-board writing with a programmer, incorrect programming or erasing may occur unless the power-on procedure designated by the programmer makers is applied.

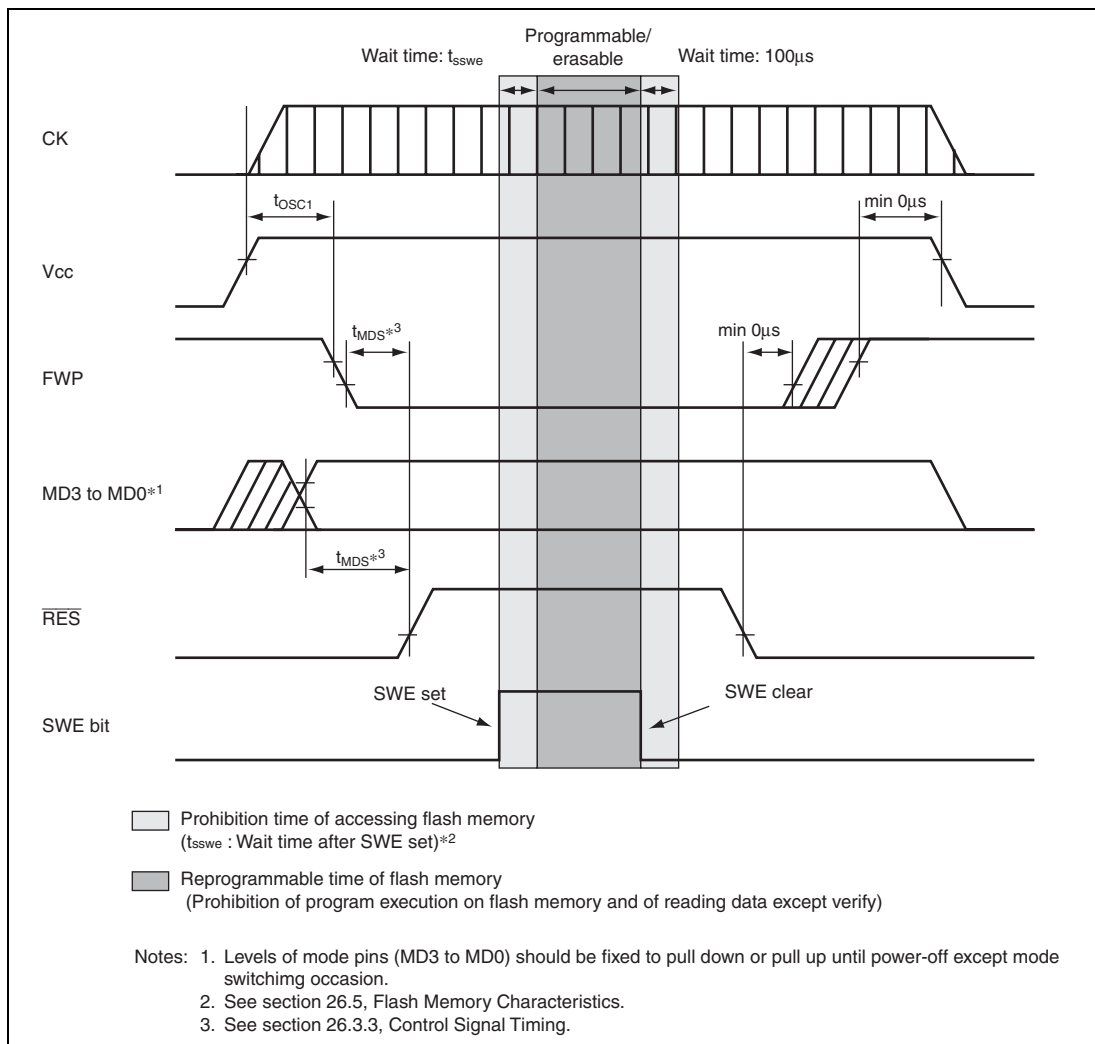

Figure 19.11 Power On/Off Timing (Boot Mode)

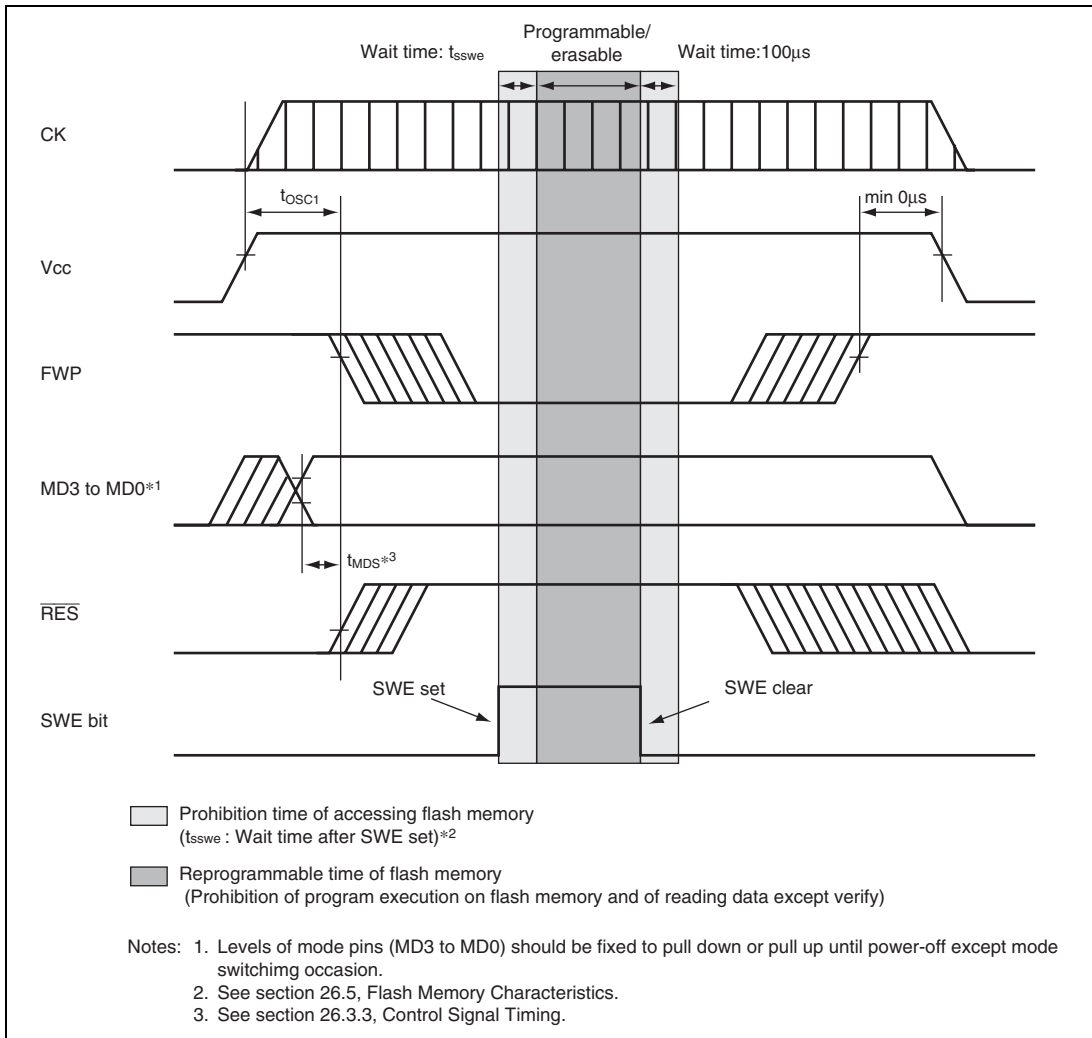

Figure 19.12 Power On/Off Timing (User Program Mode)

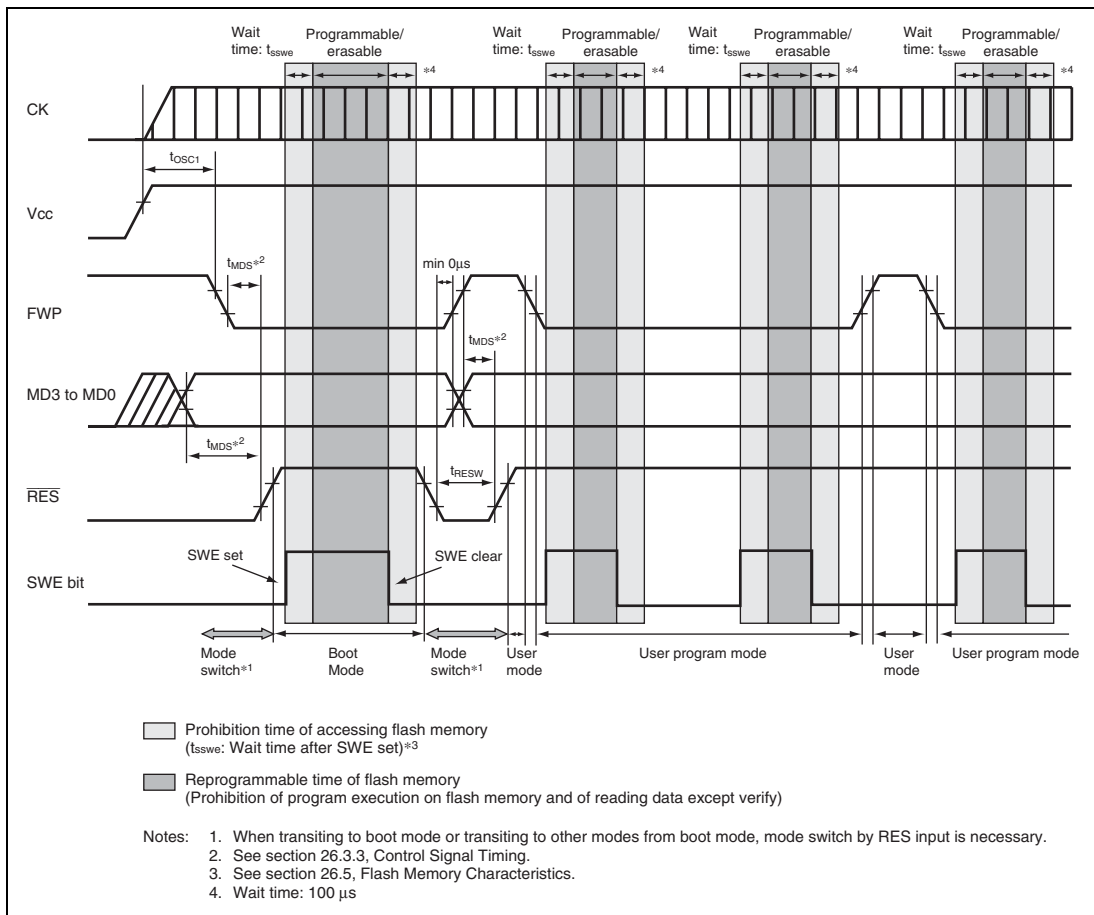

Figure 19.13 Mode Transit Timing (Example: Boot Mode → User Mode ↔ User Program Mode)

Section 20 Mask ROM

This LSI is available with 256 kbytes of on-chip mask ROM. The on-chip ROM is connected to the CPU, direct memory access controller (DMAC), and data transfer controller (DTC) through a 32-bit data bus (figure 20.1). The CPU, DMAC, and DTC can access the on-chip ROM in 8, 16 and 32-bit widths. Data in the on-chip ROM can always be accessed in one cycle.

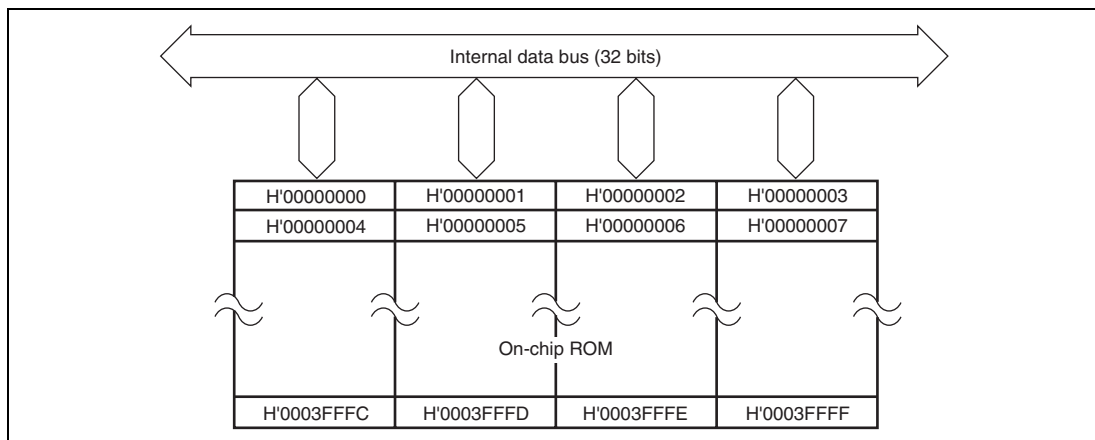

Figure 20.1 Mask ROM Block Diagram

The operating mode determines whether the on-chip ROM is valid or not. The operating mode is selected using mode-setting pins FWP and MD3-MD0 as shown in table 3.1. If you are using the on-chip ROM, select mode 2 or mode 3; if you are not, select mode 0 or 1. The on-chip ROM is allocated to addresses H'00000000 to H'0003FFFF of memory area 0.

20.1 Usage Note

- Module Standby Mode Setting

Access to the on-chip ROM can be enabled/disabled by the module standby control register (MSTCR1). The initial value enables the on-chip ROM operation. On-chip ROM access is disabled by setting the module standby mode. For details, see section 24, Power-Down Modes.

Section 21 RAM

This LSI has an on-chip high-speed static RAM. The on-chip RAM is connected to the CPU, direct memory access controller (DMAC), data transfer controller (DTC), and advanced user debugger (AUD)* by a 32-bit data bus, enabling 8, 16, or 32-bit width access to data in the on-chip RAM. Data in the on-chip RAM can always be accessed in one cycle, providing high-speed access that makes this RAM ideal for use as a program area, stack area, or data area. The on-chip RAM is allocated to address H'FFFFE000 to H'FFFFFFF. The contents of the on-chip RAM are retained in sleep mode and standby mode, and by a power-on reset and a manual reset.

The on-chip RAM can be enabled or disabled by means of the RAME bit in the system control register (SYSCR). For details on the system control register (SYSCR), refer to section 24.2.2, System Control Register (SYSCR).

Note: * Flash version only.

21.1 Usage Note

- Module Standby Mode Setting

RAM can be enabled/disabled by the module standby control register (MSTCR1). The initial value enables RAM operation. RAM access is disabled by setting the module standby mode. For details, see section 24, Power-Down Modes.

Section 22 User Debugging Interface (H-UDI)

22.1 Overview

The user debugging interface (H-UDI) provides data transfer and interrupt request functions. The H-UDI performs serial transfer by means of external signal control.

22.1.1 Features

The H-UDI has the following features:

- Five test signals (TCK, TDI, TDO, TMS, and $\overline{\text{TRST}}$)
- TAP controller
- Two instructions
 - Bypass mode
 - Test mode conforming to IEEE 1149.1
 - H-UDI interrupt
 - H-UDI interrupt request to INTC

Note: This LSI does not support test modes other than the bypass mode.

22.1.2 Block Diagram

Figure 22.1 shows a block diagram of the H-UDI.

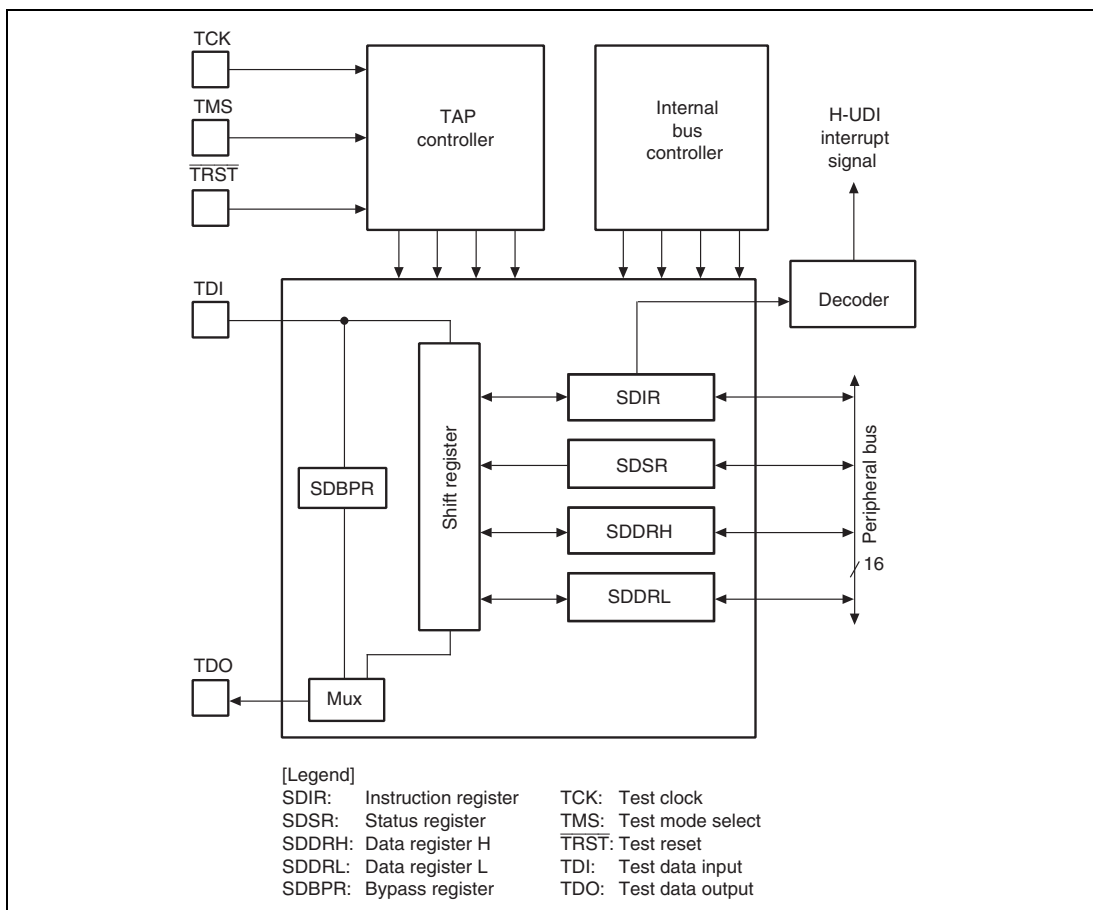

Figure 22.1 H-UDI Block Diagram

22.2 Input/Output Pins

Table 22.1 shows the H-UDI pin configuration.

Table 22.1 H-UDI Pins

| Pin Name | Abbreviation | I/O | Function |
|------------------|--------------------------|--------|--|
| Test clock | TCK | Input | <p>Test Clock Input</p> <p>TCK supplies an independent clock to the H-UDI. As the clock input to TCK is supplied directly to the H-UDI, a clock waveform with a duty cycle close to 50% should be input (see section 26, Electrical Characteristics, for details).</p> |
| Test mode select | TMS | Input | <p>Test Mode Select Input Signal</p> <p>TMS is sampled at the rising edge of TCK. TMS controls the internal state of the TAP controller.</p> |
| Test data input | TDI | Input | <p>Serial Data Input</p> <p>TDI performs serial input of instructions and data to H-UDI registers. TDI is sampled at the rising edge of TCK.</p> |
| Test data output | TDO | Output | <p>Serial Data Output</p> <p>TDO performs serial output of instructions and data from H-UDI registers. Transfer is synchronized with TCK. When no signal is being output, TDO goes to the high-impedance state.</p> |
| Test reset | $\overline{\text{TRST}}$ | Input | <p>Test Reset Input Signal</p> <p>$\overline{\text{TRST}}$ is used to initialize the H-UDI asynchronously.</p> |

22.3 Register Description

The H-UDI has the following registers. For the register addresses and register states in each operating mode, refer to section 25, List of Registers.

- Instruction register (SDIR)
- Status register (SDSR)
- Data register H (SDDRH)
- Data register L (SDDRL)
- Bypass register (SDBPR)

Instructions and data can be input to the instruction register (SDIR) and data register (SDDR) by serial transfer from the test data input pin (TDI). Data from the status register (SDSR), and SDDR can be output via the test data output pin (TDO). The bypass register (SDBPR) is a one-bit register that is connected to TDI and TDO in bypass mode. Except for SDBPR, all the registers can be accessed by the CPU.

Table 22.2 shows the kinds of serial transfer that can be used with each of the H-UDI's registers.

Table 22.2 Serial Transfer Characteristics of H-UDI Registers

| Register | Serial Input | Serial Output |
|-----------------|---------------------|----------------------|
| SDIR | Possible | Not possible |
| SDSR | Not possible | Possible |
| SDDRH | Possible | Possible |
| SDDRL | Possible | Possible |
| SDBPR | Possible | Possible |

22.3.1 Instruction Register (SDIR)

The instruction register (SDIR) is a 16-bit register that can be read, but not written to, by the CPU. H-UDI instructions can be transferred to SDIR from TDI by serial input. SDIR can be initialized by the $\overline{\text{TRST}}$ signal, but is not initialized in software standby mode.

Instructions transferred to SDIR must be 4 bits in length. If an instruction exceeding 4 bits is input, the last 4 bits of the serial data will be stored in SDIR.

| Bit | Bit Name | Initial value | R/W | Description |
|---------------|----------|---------------|-----|--|
| 15 | TS3 | 1 | R | Test Set Bit |
| 14 | TS2 | 1 | R | 0xxx: setting prohibited |
| 13 | TS1 | 1 | R | 100x: setting prohibited |
| 12 | TS0 | 1 | R | 1010: H-UDI interrupt 1011: setting prohibited 110x: setting prohibited 1110: setting prohibited 1111: BYPASS mode |
| [Legend] | | | | |
| X: Don't care | | | | |
| 11 to 0 | — | All 0 | R | Reserved These bits are always read as 0. The write value should always be 0. |

22.3.2 Status Register (SDSR)

The status register (SDSR) is a 16-bit register that can be read and written to by the CPU. The SDSR value can be output from TDO, but serial data cannot be written to SDSR via TDI. The SDTRF bit is output by means of a one-bit shift. In a two-bit shift, the SDTRF bit is output first, followed by a reserved bit.

SDSR is initialized by $\overline{\text{TRST}}$ signal input, but is not initialized in software standby mode.

| Bit | Bit Name | Initial value | R/W | Description |
|----------|----------|---------------|-----|---|
| 15 to 12 | — | All 0 | R | Reserved These bits are always read as 0. The write value should always be 0. |
| 11 | — | 1 | R | Reserved This bit is always read as 1. The write value should always be 1. |
| 10 to 1 | — | All 0 | R | Reserved These bits are always read as 0. The write value should always be 0. |
| 0 | SDTRF | 1 | R/W | Serial Data Transfer Control Flag Indicates whether H-UDI registers can be accessed by the CPU. The SDTRF bit is initialized by the $\overline{\text{TRST}}$ signal, but is not initialized in software standby mode. 0: Serial transfer to SDDR has ended, and SDDR can be accessed 1: Serial transfer to SDDR is in progress |

22.3.3 Data Register (SDDR)

The data register (SDDR) comprises data register H (SDDRH) and data register L (SDDRL).

SDDRH and SDDRL are 16-bit registers that can be read and written to by the CPU. SDDR is connected to TDO and TDI for serial data transfer to and from an external device.

32-bit data is input and output in serial data transfer. If data exceeding 32 bits is input, only the last 32 bits will be stored in SDDR. Serial data is input starting with the MSB of SDDR (bit 15 of SDDRH), and output starting with the LSB (bit 0 of SDDRL).

SDDR is not initialized by a reset, in software standby mode, or by the $\overline{\text{TRST}}$ signal.

The initial value of SDDR is undefined.

22.3.4 Bypass Register (SDBPR)

The bypass register (SDBPR) is a one-bit shift register. In bypass mode, SDBPR is connected to TDI and TDO, and this LSI is bypassed in a board test. SDBPR cannot be read or written to by the CPU.

22.4 Operation

22.4.1 H-UDI Interrupt

When an H-UDI interrupt instruction is transferred to SDIR via TDI, an interrupt is generated. Data transfer can be controlled by means of the H-UDI interrupt service routine. Transfer can be performed by means of SDDR.

Control of data input/output between an external device and the H-UDI is performed by monitoring the SDTRF bit in SDSR externally and internally. Internal SDTRF bit monitoring is carried out by having SDSR read by the CPU.

The H-UDI interrupt and serial transfer procedure is as follows.

1. An instruction is input to SDIR by serial transfer, and an H-UDI interrupt request is generated.
2. After the H-UDI interrupt request is issued, the SDTRF bit in SDSR is monitored externally. After output of SDTRF = 1 from TDO is observed, serial data is transferred to SDDR.
3. On completion of the serial transfer to SDDR, the SDTRF bit is cleared to 0, and SDDR can be accessed by the CPU. After SDDR has been accessed, SDDR serial transfer is enabled by setting the SDTRF bit in SDSR to 1.
4. Serial data transfer between an external device and the H-UDI can be carried out by constantly monitoring the SDTRF bit in SDSR externally and internally.

Figure 22.2, figure 22.3, and figure 22.4 show the timing of data transfer between an external device and the H-UDI.

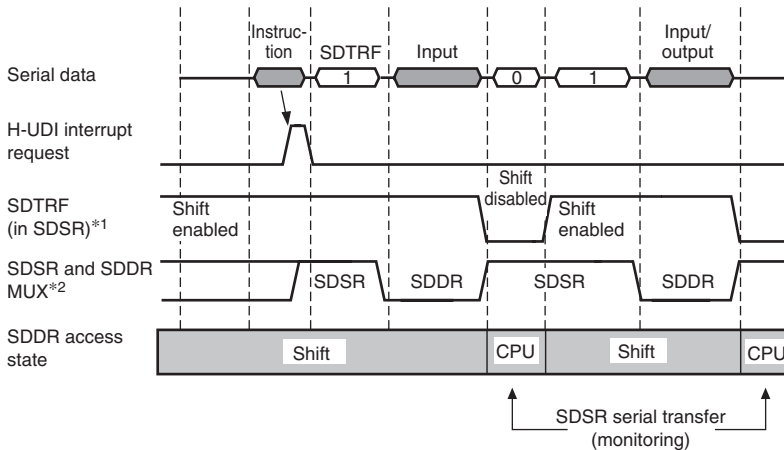

Notes: 1. SDTRF flag (in SDR): Indicates whether SDDR access by the CPU or serial transfer data input/output to SDDR is possible.

| | |
|---|--|
| 1 | SDDR is shift-enabled. Do not access SDDR until SDTRF = 0. |
| 0 | SDDR is shift-disabled. SDDR access by the CPU is enabled. |

- Conditions:
- SDTRF = 1
 - When $\overline{\text{TRST}} = 0$
 - When the CPU writes 1
 - In bypass mode
 - SDTRF = 0
 - End of SDDR shift access in serial transfer

2. SDSR/SDDR (Update-DR state) internal MUX switchover timing
- Switchover from SDSR to SDDR: On completion of serial transfer in which SDTRF = 1 is output from TDO
 - Switchover from SDDR to SDSR: On completion of serial transfer to SDDR

Figure 22.2 Data Input/Output Timing Chart (1)

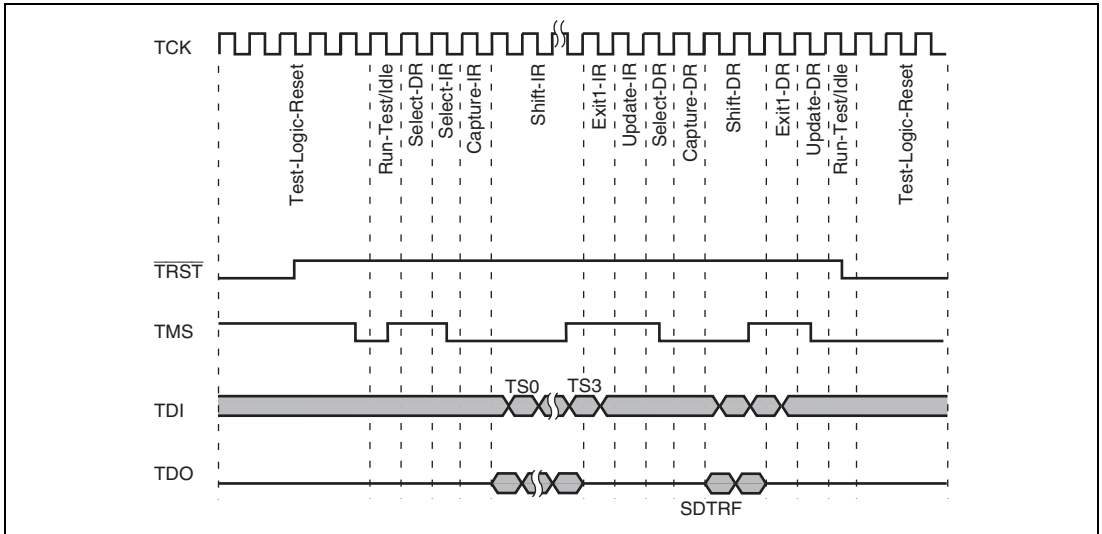

Figure 22.3 Data Input/Output Timing Chart (2)

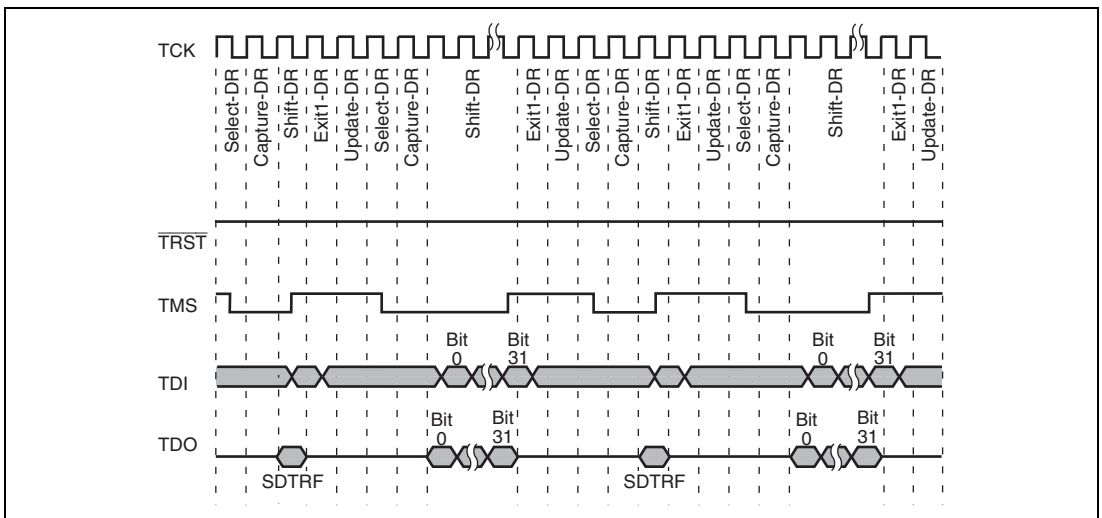

Figure 22.4 Data Input/Output Timing Chart (3)

22.4.2 Bypass Mode

Bypass mode can be used to bypass this LSI in a boundary-scan test. Bypass mode is entered by transferring B'1111 to SDIR. In bypass mode, SDBPR is connected to TDI and TDO.

22.4.3 H-UDI Reset

The H-UDI can be reset as follows.

- By holding the $\overline{\text{TRST}}$ signal at 0
- When $\overline{\text{TRST}} = 1$, by inputting at least five TCK clock cycles while $\text{TMS} = 1$

22.5 Usage Notes

- The registers are not initialized in software standby mode. If $\overline{\text{TRST}}$ is set to 0 in software standby mode, bypass mode will be entered.
- The frequency of TCK must be lower than that of the peripheral module clock ($P\phi$). For details, see section 26, Electrical Characteristics.
- In serial data transfer, data input/output starts with the LSB. Figure 22.5 shows serial data input/output.
- If the H-UDI serial transfer sequence is disrupted, a $\overline{\text{TRST}}$ reset must be executed. Transfer should then be retried, regardless of the transfer operation.
- The TDO output timing is from the rise of TCK.
- In the Shift-IR state, the lower 2 bits of the output data from TDO (the IR status word) may not always be 01.
- If more than 32 bits are serially transferred, serial data exceeding 32 bits output from TDO should be ignored.
- The TDI pin must not be in the high-impedance state.

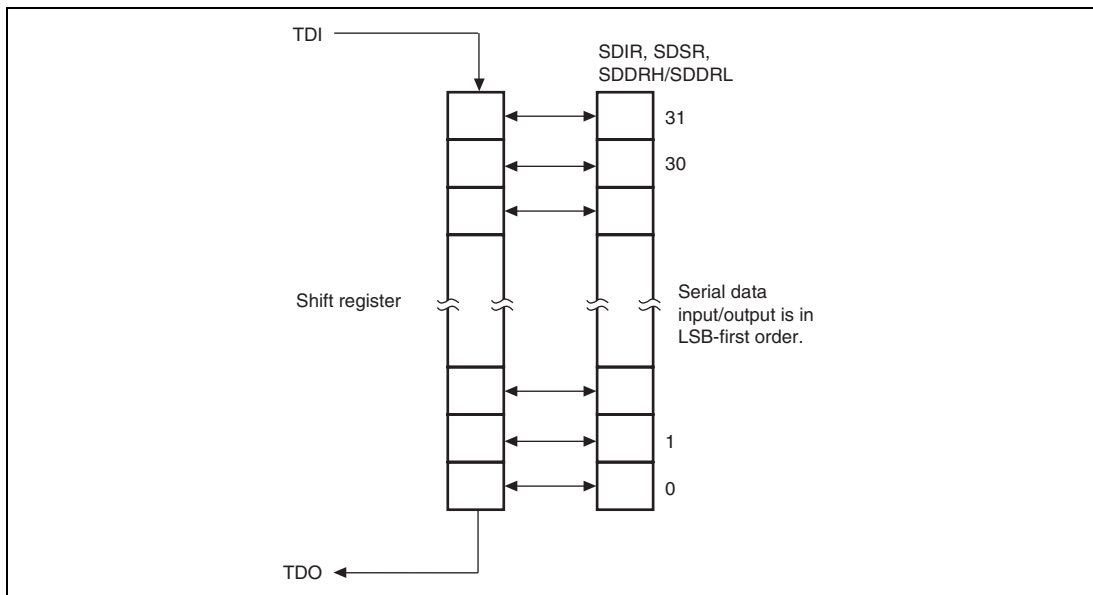

Figure 22.5 Serial Data Input/Output

Section 23 Advanced User Debugger (AUD)

23.1 Overview

This LSI has an on-chip advanced user debugger (AUD). Use of the AUD simplifies the construction of a simple emulator, with functions such as acquisition of branch trace data and monitoring/tuning of on-chip RAM data.

AUD can be enabled or disabled using the AUDSRST bit in the system control register (SYSCR). Refer to section 24.2.2, System Control Register (SYSCR), for SYSCR.

23.1.1 Features

The AUD has the following features:

- Eight input/output pins
 - Data bus (AUDATA3-AUDATA0)
 - AUD reset ($\overline{\text{AUDRST}}$)
 - AUD sync signal ($\overline{\text{AUDSYNC}}$)
 - AUD clock (AUDCK)
 - AUD mode (AUDMD)
- Two modes
 - Branch trace mode
 - RAM monitor mode

23.1.2 Block Diagram

Figure 23.1 shows a block diagram of the AUD.

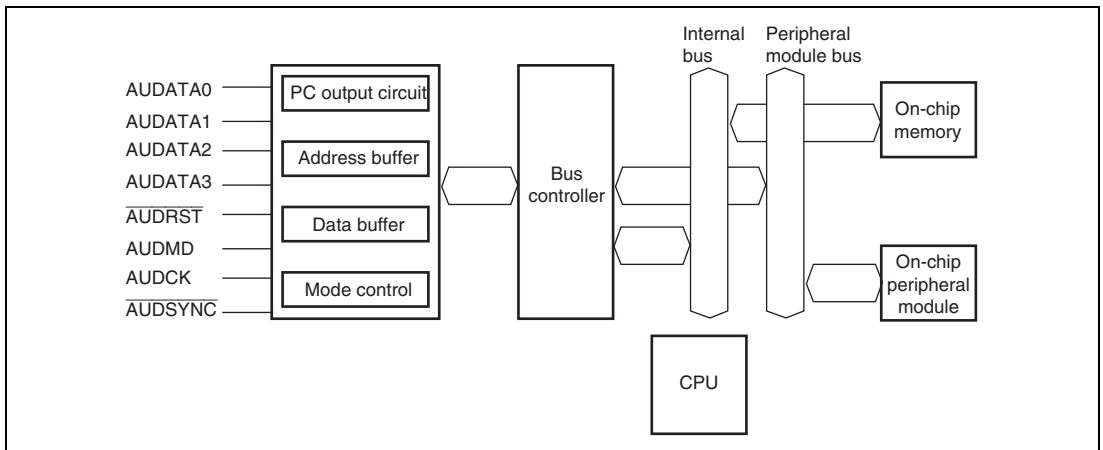

Figure 23.1 AUD Block Diagram

23.2 Input/Output Pins

Table 23.1 shows the AUD's input/output pins.

Table 23.1 AUD Pin Configuration

| Name | Abbreviation | Function | |
|-----------------|-----------------------------|---|--|
| | | Branch Trace Mode | RAM Monitor Mode |
| AUD data | AUDATA3 to AUDATA0 | Branch destination address output | Monitor address/data input/output |
| AUD reset | $\overline{\text{AUDRST}}$ | AUD reset input | AUD reset input |
| AUD mode | AUDMD | Mode select input (L) | Mode select input (H) |
| AUD clock | AUDCK | Sync clock ($\phi/2$) output | Sync clock input |
| AUD sync signal | $\overline{\text{AUDSYNC}}$ | Data start position identification signal output | Data start position identification signal input |

23.2.1 Pin Descriptions

- Pins Used in Both Modes

| Pin | Description |
|----------------------------|--|
| AUDMD | The mode is selected by changing the input level at this pin. Low: Branch trace mode High: RAM monitor mode The input at this pin should be changed when $\overline{\text{AUDRST}}$ is low. |
| $\overline{\text{AUDRST}}$ | The AUD's internal buffers and logic are initialized by inputting a low level to this pin. When this signal goes low, the AUD enters the reset state and the AUD's internal buffers and logic are reset. When $\overline{\text{AUDRST}}$ goes high again after the AUDMD level settles, the AUD starts operating in the selected mode. |

- Pin Functions in Branch Trace Mode

| Pin | Description |
|-----------------------|---|
| AUDCK | This pin outputs 1/2 the operating frequency ($\phi/2$). This is the clock for AUDATA synchronization. |
| AUDSYNC | This pin indicates whether output from AUDATA is valid. High: Valid address data is not being output Low: Valid address is being output |
| AUDATA3 to AUDATA0 | <p>1. When $\overline{\text{AUDSYNC}}$ is low</p> <p>When a program branch or interrupt branch occurs, the AUD asserts AUDSYNC and outputs the branch destination address. The output order is as follows: A3 to A0, A7 to A4, A11 to A8, A15 to A12, A19 to A16, A23 to A20, A27 to A24, A31 to A28.</p> <p>2. When $\overline{\text{AUDSYNC}}$ is high</p> <p>When waiting for branch destination address output, these pins constantly output 0011.</p> <p>When an branch occurs, AUDATA3 and AUDATA2 output 10, and AUDATA1 and AUDATA0 indicate whether a 4-, 8-, 16-, or 32-bit address is to be output by comparing the previous fully output address with the address output this time (see table below).</p> |

| AUDATA1 and AUDATA0 Settings | |
|------------------------------|---|
| 00 | Address bits A31 to A4 match; 4 address bits A3 to A0 are to be output (i.e. output is performed once). |
| 01 | Address bits A31 to A8 match; 8 address bits A3 to A0 and A7 to A4 are to be output (i.e. output is performed twice). |
| 10 | Address bits A31 to A16 match; 16 address bits A3 to A0, A7 to A4, A11 to A8, and A15 to A12 are to be output (i.e. output is performed four times). |
| 11 | None of the above cases applies; 32 address bits A3 to A0, A7 to A4, A11 to A8, A15 to A12, A19 to A16, A23 to A20, A27 to A24, and A31 to A28 are to be output (i.e. output is performed eight times). |

- Pin Functions in RAM Monitor Mode

| Pin | Description |
|-----------------------------|---|
| AUDCK | The external clock input pin. Input the clock to be used for debugging to this pin. The input frequency must not exceed 1/4 the operating frequency. |
| $\overline{\text{AUDSYNC}}$ | Do not assert this pin until a command is input to AUDATA externally and the necessary data can be prepared. For details, see the protocol description in the following. |
| AUDATA3 to AUDATA0 | When a command is input externally, data is output after Ready transmit. Output starts when $\overline{\text{AUDSYNC}}$ is negated. For details, see the protocol description in the following. |

23.3 Branch Trace Mode

23.3.1 Overview

In this mode, the branch destination address is output when a branch occurs in the user program. Branches may be caused by branch instruction execution or interrupt/exception processing, but no distinction is made between the two in this mode.

23.3.2 Operation

Operation starts in branch trace mode when $\overline{\text{AUDRST}}$ is asserted, AUDMD is driven low, and then $\overline{\text{AUDRST}}$ is negated.

Figure 23.2 shows an example of data output.

While the user program is being executed without branches, the AUDATA pins constantly output 0011 in synchronization with AUDCK .

When a branch occurs, after execution starts at the branch destination address in the PC, the previous fully output address (i.e. for which output was not interrupted by the occurrence of another branch) is compared with the current branch address, and depending on the result, $\overline{\text{AUDSYNC}}$ is asserted and the branch destination address output after 1-clock output of 1000 (in the case of 4-bit output), 1001 (8-bit output), 1010 (16-bit output), or 1011 (32-bit output). The initial value of the compared address is H'00000000.

On completion of the cycle in which the address is output, $\overline{\text{AUDSYNC}}$ is negated and 0011 is simultaneously output from the AUDATA pins.

If another branch occurs during branch destination address output, the later branch has priority for output. In this case, $\overline{\text{AUDSYNC}}$ is negated and the AUDATA pins output the address after outputting 10xx again (figure 23.3 shows an example of the output when consecutive branches occur). Note that the compared address is the previous fully output address, and not an interrupted address (since the upper address of an interrupted address will be unknown).

The interval from the start of execution at the branch destination address in the PC until the AUDATA pins output 10xx is 1.5 or 2 AUDCK cycles.

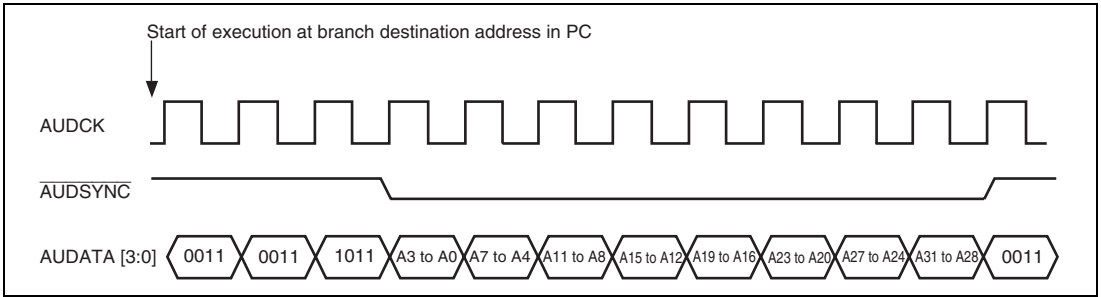

Figure 23.2 Example of Data Output (32-Bit Output)

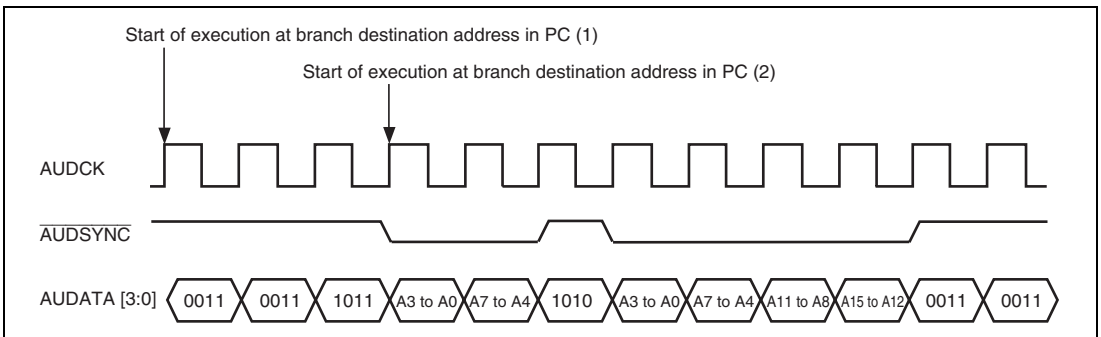

Figure 23.3 Example of Output in Case of Successive Branches

23.4 RAM Monitor Mode

23.4.1 Overview

In this mode, all the modules connected to this LSI's internal or external bus can be read and written to, allowing RAM monitoring and tuning to be carried out.

When an address is written to AUDATA externally, the data corresponding to that address is output. If an address and data are written to AUDATA, the data is transferred to the address.

23.4.2 Communication Protocol

The AUD latches the AUDATA input when $\overline{\text{AUDSYNC}}$ is asserted. The following AUDATA input format should be used.

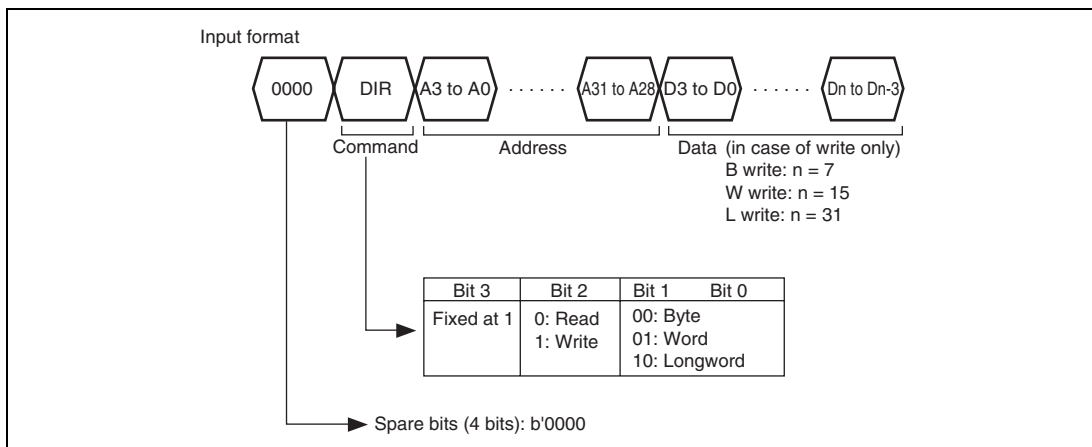

Figure 23.4 AUDATA Input Format

23.4.3 Operation

Operation starts in RAM monitor mode when $\overline{\text{AUDRST}}$ is asserted, AUDMD is driven high, then $\overline{\text{AUDRST}}$ is negated.

Figure 23.5 shows an example of a read operation, and figure 23.6 an example of a write operation.

When $\overline{\text{AUDSYNC}}$ is asserted, input from the AUDATA pins begins. When a command, address, or data (writing only) is input in the format shown in figure 23.4, execution of read/write access to the specified address is started. During internal execution, the AUD returns Not Ready (0000). When execution is completed, the Ready flag (0001) is returned (figures 23.5 and 23.6). Table 23.2 shows the Ready flag format.

In a read, data of the specified size is output when $\overline{\text{AUDSYNC}}$ is negated following detection of this flag (figure 23.5).

If a command other than the above is input in DIR, the AUD treats this as a command error, disables processing, and sets bit 1 in the Ready flag to 1. If a read/write operation initiated by the command specified in DIR causes a bus error, the AUD disables processing and sets bit 2 in the Ready flag to 1 (figure 23.7).

Bus error conditions are shown below.

1. Word access to address $4n+1$ or $4n+3$
2. Longword access to address $4n+1$, $4n+2$, or $4n+3$
3. Longword access to on-chip I/O 8-bit area
4. Access to external area in single-chip mode

Table 23.2 Ready Flag Format

| Bit 3 | Bit 2 | Bit 1 | Bit 0 |
|------------|----------------------------------|--------------------------------------|--------------------------|
| Fixed at 0 | 0: Normal status 1: Bus error | 0: Normal status 1: Command error | 0: Not ready 1: Ready |

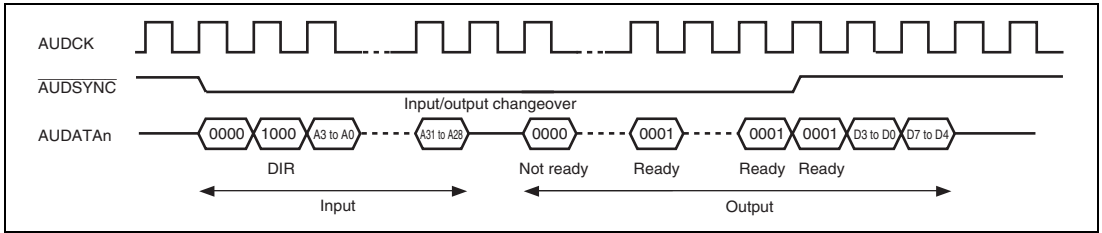

Figure 23.5 Example of Read Operation (Byte Read)

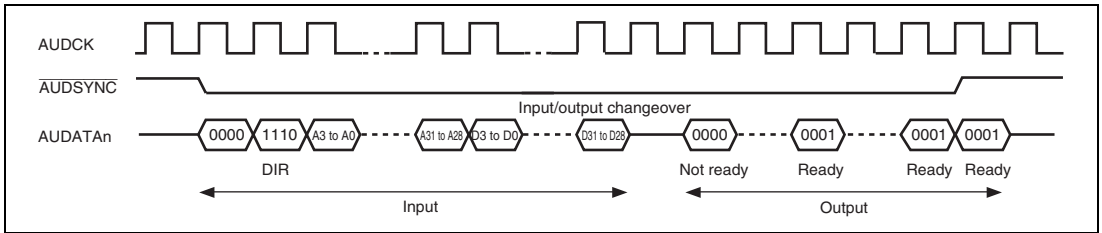

Figure 23.6 Example of Write Operation (Longword Write)

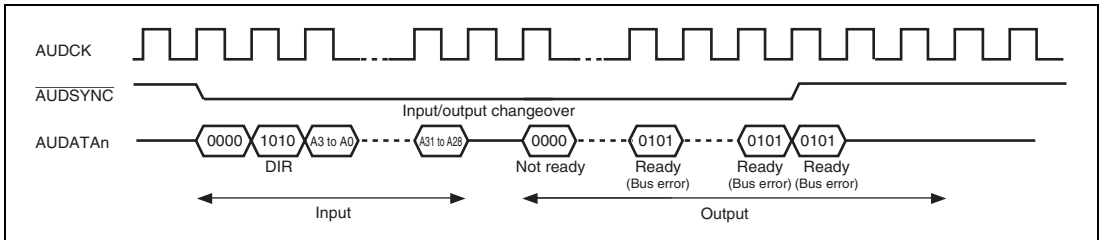

Figure 23.7 Example of Error Occurrence (Longword Read)

23.5 Usage Notes

23.5.1 Initialization

The debugger's internal buffers and processing states are initialized in the following cases:

1. In a power-on reset
2. When $\overline{\text{AUDRST}}$ is driven low
3. When the AUDSRST bit in the SYSCR register is cleared to 0 (see section 24.2.2, System Control Register (SYSCR))
4. When the MSTP3 bit in the MSTCR2 register is set to 1 (see section 24.2.3, Module Standby Control Register 1 and 2 (MSTCR1 and MSTCR2))

23.5.2 Operation in Software Standby Mode

The debugger is not initialized in software standby mode. However, since this LSI's internal operation halts in software standby mode:

1. When AUDMD is high (RAM monitor mode), Ready is not returned (Not Ready continues to be returned).
However, when operating on an external clock, the protocol continues.
2. When AUDMD is low (branch trace mode), operation stops. However, operation continues when software standby is released.

23.5.3 Setting the PA15/CK pin

Some debug tools have specification that the AUDCK signal is generated out of the CK signal. Decide the pin function controller setting after reading the manual of the debug tool to be used.

23.5.4 Pin States

1. Module standby

| | |
|-----------------------------|---|
| AUDMD | Z |
| AUDCK | Z |
| $\overline{\text{AUDSYNC}}$ | Z |
| AUDATA | Z |

2. $\overline{\text{AUDRST}}$ = low-level input

| | | |
|-----------------------------|-------------------------|------------------------------------|
| AUDMD | Input | |
| AUDCK | (1) AUDMD = high: Input | (2) AUDMD = low: High-level Output |
| $\overline{\text{AUDSYNC}}$ | (1) AUDMD = high: Input | (2) AUDMD = low: High-level Output |
| $\overline{\text{AUDRST}}$ | Low-level input | |
| AUDATA | (1) AUDMD = high: Input | (2) AUDMD = low: High-level Output |

3. Normal operation/software standby

| | | |
|------------------------------|--------------------------------|-------------------------|
| $\overline{\text{AUDRST}}$ = | 1 | |
| AUDMD | Input | |
| AUDCK | (1) AUDMD = high: Input | (2) AUDMD = low: Output |
| $\overline{\text{AUDSYNC}}$ | (1) AUDMD = high: Input | (2) AUDMD = low: Output |
| $\overline{\text{AUDRST}}$ | High-level input | |
| AUDATA | (1) AUDMD = high: Input/Output | (2) AUDMD = low: Output |

23.5.5 AUD Start-up Sequence

Follow the sequence described below to start up the AUD.

After selecting the $\overline{\text{AUD}}$ pin by the PFC, input at least three clocks to the AUDCK pin while retaining the $\overline{\text{AUDRST}}$ pin at low level. Then, set the AUD reset bit (AUDSRST) in SYSCR to clear the AUD reset. Low level input to the $\overline{\text{AUDRST}}$ pin and clock input to the AUDCK pin can be started prior to the selection of the $\overline{\text{AUD}}$ pin by the PFC.

23.5.6 RAM Monitor Operation Using the PD22/AUDCK Pin

While using the PD22/AUDCK pin for RAM monitor function, the PE3/AUDATA3, PE4/AUDATA2, PE5/AUDATA1, PE6/AUDATA0, and PA16/ $\overline{\text{AUDSYNC}}$ pins are not available. Instead of those unavailable pins, the PD19/AUDATA3, PD18/AUDATA2, PD17/AUDATA1, PD16/AUDATA0 and PD23/ $\overline{\text{AUDSYNC}}$ pins must be used.

23.5.7 Settings of AUD-Related Pins when Using E10A

When using the E10A and AUD functions of the SH7145, use port D and the multiplexed AUD-related pins.

Section 24 Power-Down Modes

In addition to the normal program execution state, this LSI has three power-down modes in which operation of the CPU and oscillator is halted and power dissipation is reduced. Low-power operation can be achieved by individually controlling the CPU, on-chip peripheral functions, and so on.

This LSI's power-down modes are as follows:

- Sleep mode
- Software standby mode
- Module standby mode

Sleep mode indicates the state of the CPU, and module standby mode indicates the state of the on-chip peripheral function (including the bus master other than the CPU). Some of these states can be combined.

After a reset, the LSI is in normal-operation mode.

Table 24.1 lists internal operation states in each mode.

Table 24.1 Internal Operation States in Each Mode

| Function | | Normal Operation | Sleep | Module Standby | Software Standby |
|------------------------------|--------------|------------------|-------------------|-------------------|-------------------|
| System clock pulse generator | | Functioning | Functioning | — | Halted |
| CPU | | Functioning | Halted (retained) | — | Halted (retained) |
| External interrupts | NMI | Functioning | Functioning | — | Functioning |
| | IRQ7 to IRQ0 | | | | |
| Peripheral functions | UBC | Functioning | Functioning | Halted (reset) | Halted (retained) |
| | DMAC | Functioning | Functioning | Halted (reset) | Halted (reset) |
| | DTC | | | | |
| | IIC | | | | |
| | I/O port | Functioning | Functioning | — | Halted (retained) |
| | WDT | Functioning | Functioning | — | Halted (retained) |
| | SCI | Functioning | Functioning | Halted (reset) | Halted (reset) |
| | A/D | | | | |
| | MTU | | | | |
| | CMT | | | | |
| | H-UDI | Functioning | Functioning | Halted (retained) | Halted (retained) |
| | AUD | Functioning | Functioning | Halted (reset) | Halted (reset) |
| | ROM | | | | |
| | RAM | Functioning | Functioning | Halted (retained) | Halted (retained) |

- Notes:
1. "Halted (retained)" means that the operation of the internal state is suspended, although internal register values are retained.
 2. "Halted (reset)" means that internal register values and internal state are initialized.
 3. In module standby mode, only modules for which a stop setting has been made are halted (reset or retained).
 4. There are two types of on-chip peripheral module registers; ones which are initialized by module standby mode or software standby mode, and those not initialized by that mode. For details, refer to section 25.3, Register States in Each Operating Mode.
 5. The port high-impedance bit (HIZ) in SBYCR sets the state of the I/O port in software standby mode. For details on the setting, refer to section 24.2.1, Standby Control Register (SBYCR). For the state of pins, refer to appendix A, Pin States.

24.1 Input/Output Pins

Table 24.2 lists the pins relating to power-down mode.

Table 24.2 Pin Configuration

| Pin Name | I/O | Function |
|--------------------------|-------|--------------------------|
| $\overline{\text{RES}}$ | Input | Power-on reset input pin |
| $\overline{\text{MRES}}$ | Input | Manual reset input pin |

24.2 Register Descriptions

Registers related to power down modes are shown below. For details on register addresses and register states during each process, refer to section 25, List of Registers.

- Standby control register (SBYCR)
- System control register (SYSCR)
- Module standby control register 1 (MSTCR1)
- Module standby control register 2 (MSTCR2)

24.2.1 Standby Control Register (SBYCR)

SBYCR is an 8-bit readable/writable register that performs software standby mode control.

| Bit | Bit Name | Initial Value | R/W | Description |
|--------|----------|---------------|-----|--|
| 7 | SSBY | 0 | R/W | <p>Software Standby</p> <p>This bit specifies the transition mode after executing the SLEEP instruction.</p> <p>0: Shifts to sleep mode after the SLEEP instruction has been executed</p> <p>1: Shifts to software standby mode after the SLEEP instruction has been executed</p> <p>This bit cannot be set to 1 when the watchdog timer (WDT) is operating (when the TME bit in TCSR of the WDT is set to 1). When transferring to software standby mode, clear the TME bit to 0, stop the WDT, then set the SSBY bit to 1.</p> |
| 6 | Hi-Z | 0 | R/W | <p>Port High-Impedance</p> <p>In software standby mode, this bit selects whether the pin state of the I/O port is retained or changed to high-impedance.</p> <p>0: In software standby mode, the pin state is retained.</p> <p>1: In software standby mode, the pin state is changed to high-impedance.</p> <p>The HIZ bit cannot be set to 1 when the TME bit in TCSR of the WDT is set to 1.</p> <p>When changing the pin state of the I/O port to high-impedance, clear the TME bit to 0, then set the HIZ bit to 1.</p> |
| 5 | — | 0 | R | <p>Reserved</p> <p>This bit is always read as 0, and should always be written with 0.</p> |
| 4 to 2 | — | All 1 | R | <p>Reserved</p> <p>These bits are always read as 1, and should always be written with 1.</p> |

| Bit | Bit Name | Initial Value | R/W | Description |
|-----|----------|---------------|-----|---|
| 1 | IRQEH | 1 | R/W | IRQ7 to IRQ4 Enable IRQ7 to IRQ4 interrupts are enabled to clear software standby mode. 0: Enable to clear the software standby mode 1: Disable to clear the software standby mode |
| 0 | IRQEL | 1 | R/W | IRQ3 to IRQ0 Enable IRQ3 to IRQ0 interrupts are enabled to clear software standby mode. 0: Enable to clear the software standby mode 1: Disable to clear the software standby mode |

24.2.2 System Control Register (SYSCR)

SYSCR is an 8-bit readable/writable register that performs AUD software reset control and enables/disables the access to the on-chip RAM.

| Bit | Bit Name | Initial Value | R/W | Description |
|--------|----------|---------------|-----|--|
| 7, 6 | — | All 1 | R | Reserved These bits are always read as 1, and should always be written with 1. |
| 5 to 2 | — | All 0 | R | Reserved These bits are always read as 0, and should always be written with 0. |
| 1 | AUDSRST | 0 | R/W | AUD Software Reset This bit controls the AUD reset by software. When 0 is written to AUDSRST, AUD module shifts to power-on reset state. 0: Shifts to AUD reset state. 1: Clears the AUD reset. |
| 0 | RAME | 1 | R/W | RAM Enable This bit enables/disables the on-chip RAM. 0: On-chip RAM disabled 1: On-chip RAM enabled When this bit is cleared to 0, the access the on-chip RAM is disabled. In this case, an undefined value is returned when reading or fetching the data or instruction from the on-chip RAM, and writing to the on-chip RAM is ignored. When RAME is cleared to 0 to disable the on-chip RAM, an instruction to access the on-chip RAM should not be set next to the instruction to write to SYSCR. If such an instruction is set, normal access is not guaranteed. When RAME is set to 1 to enable the on-chip RAM, an instruction to read SYSCR should be set next to the instruction to write to SYSCR. If an instruction to access the on-chip RAM is set next to the instruction to write to SYSCR, normal access is not guaranteed. |

24.2.3 Module Standby Control Register 1 and 2 (MSTCR1 and MSTCR2)

MSTCR, comprising two 16-bit readable/writable registers, performs module standby mode control. Setting a bit to 1, the corresponding module enters module standby mode, while clearing the bit to 0 clears the module standby mode.

- MSTCR1

| Bit | Bit Name | Initial Value | R/W | Description |
|----------|----------|---------------|-----|--|
| 15 to 12 | — | All 1 | R | Reserved These bits are always read as 1, and should always be written with 1. |
| 11 | MSTP27 | 0 | R/W | On-chip RAM |
| 10 | MSTP26 | 0 | R/W | On-chip ROM |
| 9 | MSTP25 | 0 | R/W | Data transfer controller (DTC) |
| 8 | MSTP24 | 0 | R/W | Direct Memory Access Controller (DMAC) Set the identical value to MSTP25 and MSTP24, respectively. When setting module standby, write b'11, while clearing, write b'00. |
| 7, 6 | — | All 0 | R | Reserved These bits are always read as 0, and should always be written with 0. |
| 5 | MSTP21 | 1 | R/W | I ² C bus interface (IIC) |
| 4 | — | 1 | R | Reserved These bits are always read as 1, and should always be written with 1. |
| 3 | MSTP19 | 1 | R/W | Serial communication interface 3 (SCI_3) |
| 2 | MSTP18 | 1 | R/W | Serial communication interface 2 (SCI_2) |
| 1 | MSTP17 | 1 | R/W | Serial communication interface 1 (SCI_1) |
| 0 | MSTP16 | 1 | R/W | Serial communication interface 0 (SCI_0) |

- MSTCR2

| Bit | Bit Name | Initial Value | R/W | Description |
|---------|----------|---------------|-----|---|
| 15, 14 | — | All 1 | R | Reserved This bit is always read as 1, and should always be written with 1. |
| 13 | MSTP13 | 1 | R/W | Multi-function timer pulse unit (MTU) |
| 12 | MSTP12 | 1 | R/W | Compare match timer (CMT) |
| 11 to 8 | — | All 0 | R | Reserved These bits are always read as 0, and should always be written with 0. |
| 7, 6 | — | All 1 | R | Reserved These bits are always read as 1, and should always be written with 1. |
| 5 | MSTP5 | 1 | R/W | A/D converter (A/D1) |
| 4 | MSTP4 | 1 | R/W | A/D converter (A/D0) |
| 3 | MSTP3 | 0 | R/W | Advanced user debugger (AUD)* |
| 2 | MSTP2 | 0 | R/W | User debugging interface (H-UDI)* |
| 1 | — | 0 | R | Reserved This bit is always read as 0, and should always be written with 0. |
| 0 | MSTP0 | 0 | R/W | User break controller (UBC) |

Note: * Although this bit can be read from/written to when using E10A (in DBGMD=H), AUD or H-UDI is in normal operation regardless of the set value.

24.3 Operation

24.3.1 Sleep Mode

Transition to Sleep Mode: If SLEEP instruction is executed while the SSBY bit in SBYCR = 0, the CPU enters sleep mode. In sleep mode, CPU operation stops, however the contents of the CPU's internal registers are retained. Peripheral functions except the CPU do not stop.

In sleep mode, data should not be accessed by the DMAC, DTC, or AUD.

Clearing Sleep Mode: Sleep mode is cleared by the conditions below.

- Clearing by the power-on reset
When the $\overline{\text{RES}}$ pin is driven low, the CPU enters the reset state. When the $\overline{\text{RES}}$ pin is driven high after the elapse of the specified reset input period, the CPU starts the reset exception handling.
When an internal Power-on reset by WDT occurs, sleep mode is also cleared.
- Clearing by the manual reset
When the $\overline{\text{MRES}}$ pin is driven low while the $\overline{\text{RES}}$ pin is high, the CPU shifts to the manual reset state and thus sleep mode is cleared.
When an internal manual reset by WDT occurs, sleep mode is also cleared.

24.3.2 Software Standby Mode

Transition to Software Standby Mode: A transition is made to software standby mode if the SLEEP instruction is executed while the SSBY bit in SBYCR is set to 1. In this mode, the CPU, on-chip peripheral functions, and the oscillator, all stop.

However, the contents of the CPU's internal registers and on-chip RAM data are retained as long as the specified voltage is supplied. There are two types of on-chip peripheral module registers; ones which are initialized by software standby mode, and those not initialized by that mode. For details, refer to section 25.3, Register States in Each Operating Mode. The port high-impedance bit (Hi-Z) in SBYCR sets the state of the I/O port either to "retained" or "high-impedance". For the state of pins, refer to appendix A, Pin States. In software standby mode, the oscillator stops and thus power consumption is significantly reduced.

Clearing Software Standby Mode: Software standby mode is cleared by the condition below.

- Clearing by the NMI interrupt input

When the falling edge or rising edge of the NMI pin (selected by the NMI edge select bit (NMIE) in ICR1 of the interrupt controller (INTC)) is detected, clock oscillation is started. This clock pulse is supplied only to the watchdog timer (WDT).

After the elapse of the time set in the clock select bits (CKS2 to CKS0) in TCSR of the WDT before the transition to software standby mode, the WDT overflow occurs. Since this overflow indicates that the clock has been stabilized, clock pulse will be supplied to the entire chip after this overflow. Software standby mode is thus cleared and the NMI exception handling is started.

When clearing software standby mode by the NMI interrupt, set CKS2 to CKS0 bits so that the WDT overflow period will be longer than the oscillation stabilization time.

When software standby mode is cleared by the falling edge of the NMI pin, the NMI pin should be high when the CPU enters software standby mode (when the clock pulse stops) and should be low when the CPU returns from standby mode (when the clock is initiated after the oscillation stabilization). When software standby mode is cleared by the rising edge of the NMI pin, the NMI pin should be low when the CPU enters software standby mode (when the clock pulse stops) and should be high when the CPU returns from software standby mode (when the clock is initiated after the oscillation stabilization).

- Clearing by the $\overline{\text{RES}}$ pin

When the $\overline{\text{RES}}$ pin is driven low, clock oscillation is started. At the same time as clock oscillation is started, clock pulse is supplied to the entire chip. Ensure that the $\overline{\text{RES}}$ pin is held low until clock oscillation stabilizes. When the $\overline{\text{RES}}$ pin is driven high, the CPU starts the reset exception handling.

- Clearing by the IRQ interrupt input

When the falling edge or rising edge of the $\overline{\text{IRQ}}$ pin (selected by the IRQ7S to IRQ0S bits in ICR1 of the interrupt controller (INTC) and the IRQ7ES[1:0] to IRQ0ES[1:0] bits in ICR2) is detected, clock oscillation is started*. This clock pulse is supplied only to the watchdog timer (WDT). The IRQ interrupt priority level should be higher than the interrupt mask level set in the status register (SR) of the CPU before the transition to software standby mode.

After the elapse of the time set in the clock select bits (CKS2 to CKS0) in TCSR of the WDT before the transition to software standby mode, the WDT overflow occurs. Since this overflow indicates that the clock has been stabilized, clock pulse will be supplied to the entire chip after this overflow. Software standby mode is thus cleared and the IRQ exception handling is started.

When clearing software standby mode by the IRQ interrupt, set CKS2 to CKS0 bits so that the WDT overflow period will be longer than the oscillation stabilization time.

When software standby mode is cleared by the falling edge or both rising and falling edges of the $\overline{\text{IRQ}}$ pin, the $\overline{\text{IRQ}}$ pin should be high when the CPU enters software standby mode (when the clock pulse stops) and should be low when the CPU returns from software standby mode (when the clock is initiated after the oscillation stabilization). When software standby mode is cleared by the rising edge of the $\overline{\text{IRQ}}$ pin, the $\overline{\text{IRQ}}$ pin should be low when the CPU enters software standby mode (when the clock pulse stops) and should be high when the CPU returns from software standby mode (when the clock is initiated after the oscillation stabilization).

Note: * If the $\overline{\text{IRQ}}$ pin setting is detection at the falling edge or detection at both rising and falling edges, clock oscillation starts at the falling edge detection. If the setting is detection at the rising edge, it starts at the rising edge detection. Do not set the $\overline{\text{IRQ}}$ pin to detection at the low level.

Software Standby Mode Application Example: Figure 24.1 shows an example in which a transition is made to software standby mode at the falling edge of the NMI pin, and software standby mode is cleared at a rising edge of the NMI pin.

In this example, when the NMI pin is driven low while the NMI edge select bit (NMIE) in ICR1 is 0 (falling edge specification), an NMI interrupt is accepted. Then, the NMIE bit is set to 1 (rising edge specification) in the NMI exception service routine, the SSBY bit in SBYCR is set to 1, and a SLEEP instruction is executed to transfer to software standby mode.

Software standby mode is cleared at the rising edge of the NMI pin.

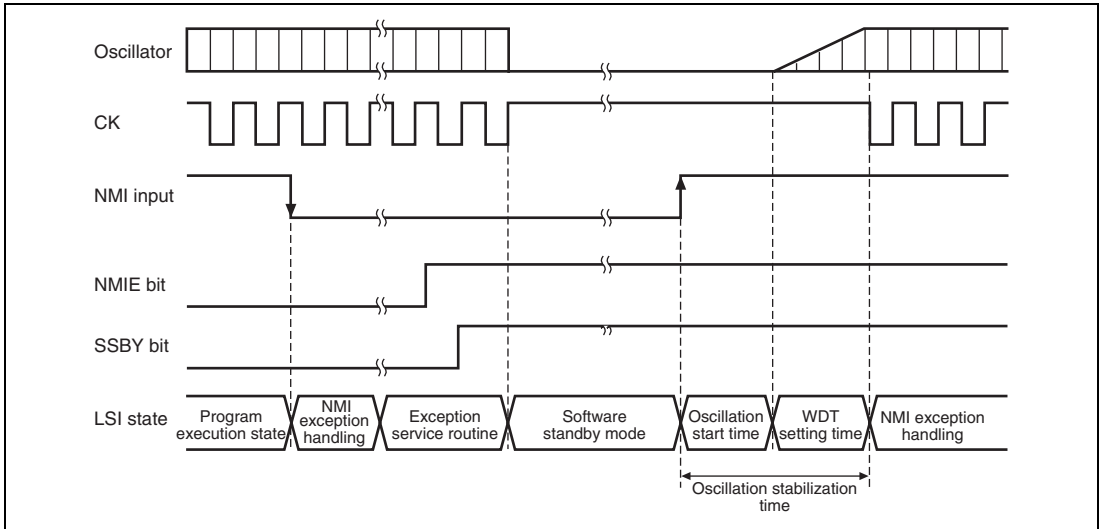

Figure 24.1 NMI Timing in Software Standby Mode (Application Example)

24.3.3 Module Standby Mode

Module standby mode can be set for individual on-chip peripheral functions.

When the corresponding MSTP bit in MSTCR is set to 1, module operation stops at the end of the bus cycle and a transition is made to module standby mode. The CPU continues operating independently.

When the corresponding MSTP bit is cleared to 0, module standby mode is cleared and the module starts operating at the end of the bus cycle. In some of the modules that have entered module standby mode, register values are initialized. Therefore, set registers again when operating the modules.

After reset clearing, the I²C, SCI, MTU, CMT, and A/D converter are in module standby mode.

The modules of registers in module standby mode cannot be read or written to.

24.4 Usage Notes

24.4.1 I/O Port Status

When a transition is made to software standby mode while the port high-impedance bit (HIZ) in SBYCR is 0, I/O port states are retained. Therefore, there is no reduction in current consumption for the output current when a high-level signal is output.

24.4.2 Current Consumption during Oscillation Stabilization Wait Period

Current consumption increases during the oscillation stabilization wait period.

24.4.3 On-Chip Peripheral Module Interrupt

Relevant interrupt operations cannot be performed in module standby mode. Consequently, if the CPU enters module standby mode while an interrupt has been requested, it will not be possible to clear the CPU interrupt source or the DMAC/DTC activation source.

Interrupts should therefore be disabled before entering module standby mode.

24.4.4 Writing to MSTCR1 and MSTCR2

MSTCR1 and MSTCR2 should only be written to by the CPU.

24.4.5 DMAC, DTC, or AUD Operation in Sleep Mode

In sleep mode, data should not be accessed by the DMAC, DTC, or AUD.

Section 25 List of Registers

This section gives information on internal I/O registers. The contents of this section are as follows:

1. Register Address Table (in the order from a lower address)
 - Registers are listed in the order from lower allocated addresses.
 - As for reserved addresses, the register name column is indicated with —. Do not access reserved addresses.
 - As for 16- or 32-bit address, the MSB addresses are shown.
 - The list is classified according to module names.
 - The register access size is shown.
2. Register Bit Table
 - Bit configurations are shown in the order of the register address table.
 - As for reserved bits, the bit name column is indicated with —.
 - As for the blank column of the bit names, the whole register is allocated to the counter or data.
 - As for 16- or 32-bit registers, bits are indicated from the MSB.
3. Register State in Each Operating Mode
 - Register states are listed in the order of the register address table.
 - Register states in the basic operating mode are shown. As for modules including their specific states such as reset, see the sections of those modules.

25.1 Register Address Table (In the Order from Lower Addresses)

Access sizes are indicated with the number of bits. Access states are indicated with the number of specified reference clock states. These values are those at 8-bit access (B), 16-bit access (W), or 32-bit access (L).

Note: Access to undefined or reserved addresses is prohibited. Correct operation cannot be guaranteed if these addresses are accessed.

| Register name | abbreviation | NO. of bits | Address | Module | Access size | NO. of Access states |
|-------------------------------------|--------------|-------------|-----------------------------|-------------|-------------|--------------------------|
| — | — | — | H'FFFF8000 to H'FFFF819F | — | — | — |
| Serial mode register_0 | SMR_0 | 8 | H'FFFF81A0 | SCI | 8, 16 | P _φ reference |
| Bit rate register_0 | BRR_0 | 8 | H'FFFF81A1 | (Channel 0) | 8 | B:2 |
| Serial control register_0 | SCR_0 | 8 | H'FFFF81A2 | | 8, 16 | W:4 |
| Transmit data register_0 | TDR_0 | 8 | H'FFFF81A3 | | 8 | |
| Serial status register_0 | SSR_0 | 8 | H'FFFF81A4 | | 8, 16 | |
| Receive data register_0 | RDR_0 | 8 | H'FFFF81A5 | | 8 | |
| Serial direction control register_0 | SDCR_0 | 8 | H'FFFF81A6 | | 8 | |
| — | — | — | H'FFFF81A7 to H'FFFF81AF | — | — | — |
| Serial mode register_1 | SMR_1 | 8 | H'FFFF81B0 | SCI | 8, 16 | |
| Bit rate register_1 | BRR_1 | 8 | H'FFFF81B1 | (Channel 1) | 8 | |
| Serial control register_1 | SCR_1 | 8 | H'FFFF81B2 | | 8, 16 | |
| Transmit data register_1 | TDR_1 | 8 | H'FFFF81B3 | | 8 | |
| Serial status register_1 | SSR_1 | 8 | H'FFFF81B4 | | 8, 16 | |
| Receive data register_1 | RDR_1 | 8 | H'FFFF81B5 | | 8 | |
| Serial direction control register_1 | SDCR_1 | 8 | H'FFFF81B6 | | 8 | |
| — | — | — | H'FFFF81B7 to H'FFFF81BF | — | — | — |
| Serial mode register_2 | SMR_2 | 8 | H'FFFF81C0 | SCI | 8, 16 | |
| Bit rate register_2 | BRR_2 | 8 | H'FFFF81C1 | (Channel 2) | 8 | |
| Serial control register_2 | SCR_2 | 8 | H'FFFF81C2 | | 8, 16 | |
| Transmit data register_2 | TDR_2 | 8 | H'FFFF81C3 | | 8 | |
| Serial status register_2 | SSR_2 | 8 | H'FFFF81C4 | | 8, 16 | |
| Receive data register_2 | RDR_2 | 8 | H'FFFF81C5 | | 8 | |
| Serial direction control register_2 | SDCR_2 | 8 | H'FFFF81C6 | | 8 | |

| Register name | abbreviation | NO. of bits | Address | Module | Access size | NO. of Access states |
|-------------------------------------|--------------|-------------|---------------------------|-----------------|-------------|---------------------------|
| — | — | — | H'FFF81C7 to H'FFF81CF | — | — | P ϕ reference B:2 |
| Serial mode register_3 | SMR_3 | 8 | H'FFF81D0 | SCI | 8, 16 | W:4 |
| Bit rate register_3 | BRR_3 | 8 | H'FFF81D1 | (Channel 3) | 8 | |
| Serial control register_3 | SCR_3 | 8 | H'FFF81D2 | | 8, 16 | |
| Transmit data register_3 | TDR_3 | 8 | H'FFF81D3 | | 8 | |
| Serial status register_3 | SSR_3 | 8 | H'FFF81D4 | SCI | 8, 16 | |
| Receive data register_3 | RDR_3 | 8 | H'FFF81D5 | (Channel 3) | 8 | |
| Serial direction control register_3 | SDCR_3 | 8 | H'FFF81D6 | | 8 | |
| — | — | — | H'FFF81D7 to H'FFF81FF | — | — | |
| Timer control register_3 | TCR_3 | 8 | H'FFF8200 | MTU | 8, 16, 32 | P ϕ reference |
| Timer control register_4 | TCR_4 | 8 | H'FFF8201 | (Channels 3, 4) | 8 | B:2 |
| Timer mode register_3 | TMDR_3 | 8 | H'FFF8202 | | 8, 16 | W:2 |
| Timer mode register_4 | TMDR_4 | 8 | H'FFF8203 | | 8 | L:4 |
| Timer I/O control register H_3 | TIORH_3 | 8 | H'FFF8204 | | 8, 16, 32 | |
| Timer I/O control register L_3 | TIORL_3 | 8 | H'FFF8205 | | 8 | |
| Timer I/O control register H_4 | TIORH_4 | 8 | H'FFF8206 | | 8, 16 | |
| Timer I/O control register L_4 | TIORL_4 | 8 | H'FFF8207 | | 8 | |
| Timer interrupt enable register_3 | TIER_3 | 8 | H'FFF8208 | | 8, 16, 32 | |
| Timer interrupt enable register_4 | TIER_4 | 8 | H'FFF8209 | | 8 | |
| Timer output master enable register | TOER | 8 | H'FFF820A | | 8, 16 | |
| Timer output control register | TOCR | 8 | H'FFF820B | | 8 | |
| — | — | — | H'FFF820C | | — | |
| Timer gate control register | TGCR | 8 | H'FFF820D | | 8 | |
| — | — | — | H'FFF820E | | — | |
| — | — | — | H'FFF820F | | — | |
| Timer counter_3 | TCNT_3 | 16 | H'FFF8210 | | 16, 32 | |
| Timer counter_4 | TCNT_4 | 16 | H'FFF8212 | | 16 | |
| Timer cyclic data register | TCDR | 16 | H'FFF8214 | | 16, 32 | |
| Timer dead time data register | TDDR | 16 | H'FFF8216 | | 16 | |
| Timer general register A_3 | TGRA_3 | 16 | H'FFF8218 | | 16, 32 | |
| Timer general register B_3 | TGRB_3 | 16 | H'FFF821A | | 16 | |
| Timer general register A_4 | TGRA_4 | 16 | H'FFF821C | | 16, 32 | |
| Timer general register B_4 | TGRB_4 | 16 | H'FFF821E | | 16 | |

25. List of Registers

| Register name | abbreviation | NO. of bits | Address | Module | Access size | NO. of Access states |
|-----------------------------------|--------------|-------------|-----------------------------|--------------------|-------------|----------------------|
| Timer sub-counter | TCNTS | 16 | H'FFFF8220 | MTU | 16, 32 | P ϕ reference |
| Timer cyclic buffer register | TCBR | 16 | H'FFFF8222 | (Channels 3, 4) | 16 | B:2 |
| Timer general register C_3 | TGRC_3 | 16 | H'FFFF8224 | | 16, 32 | W:2 |
| Timer general register D_3 | TGRD_3 | 16 | H'FFFF8226 | | 16 | L:4 |
| Timer general register C_4 | TGRC_4 | 16 | H'FFFF8228 | | 16, 32 | |
| Timer general register D_4 | TGRD_4 | 16 | H'FFFF822A | | 16 | |
| Timer status register_3 | TSR_3 | 8 | H'FFFF822C | | 8, 16 | |
| Timer status register_4 | TSR_4 | 8 | H'FFFF822D | | 8 | |
| — | — | — | H'FFFF822E to H'FFFF823F | | — | |
| Timer start register | TSTR | 8 | H'FFFF8240 | MTU | 8, 16 | P ϕ reference |
| Timer synchronous register | TSYR | 8 | H'FFFF8241 | (for all channels) | 8 | B:2 |
| — | — | — | H'FFFF8242 to H'FFFF825F | | — | W:2 |
| Timer control register_0 | TCR_0 | 8 | H'FFFF8260 | MTU | 8, 16, 32 | P ϕ reference |
| Timer mode register_0 | TMDR_0 | 8 | H'FFFF8261 | (Channel 0) | 8 | B:2 |
| Timer I/O control register H_0 | TIORH_0 | 8 | H'FFFF8262 | | 8, 16 | W:2 |
| Timer I/O control register L_0 | TIORL_0 | 8 | H'FFFF8263 | | 8 | L:4 |
| Timer interrupt enable register_0 | TIER_0 | 8 | H'FFFF8264 | | 8, 16, 32 | |
| Timer status register_0 | TSR_0 | 8 | H'FFFF8265 | | 8 | |
| Timer counter_0 | TCNT_0 | 16 | H'FFFF8266 | | 16 | |
| Timer general register A_0 | TGRA_0 | 16 | H'FFFF8268 | | 16, 32 | |
| Timer general register B_0 | TGRB_0 | 16 | H'FFFF826A | | 16 | |
| Timer general register C_0 | TGRC_0 | 16 | H'FFFF826C | | 16, 32 | |
| Timer general register D_0 | TGRD_0 | 16 | H'FFFF826E | | 16 | |
| — | — | — | H'FFFF8270 to H'FFFF827F | | — | |

| Register name | abbreviation | NO. of bits | Address | Module | Access size | NO. of Access states |
|-----------------------------------|--------------|-------------|-----------------------------|--------------------|-------------|--------------------------|
| Timer control register_1 | TCR_1 | 8 | H'FFFF8280 | MTU | 8, 16 | P _φ reference |
| Timer mode register_1 | TMDR_1 | 8 | H'FFFF8281 | (Channel 1) | 8 | B:2 |
| Timer I/O control register_1 | TIOR_1 | 8 | H'FFFF8282 | | 8 | W:2 |
| — | — | — | H'FFFF8283 | | — | L:4 |
| Timer interrupt enable register_1 | TIER_1 | 8 | H'FFFF8284 | | 8, 16, 32 | |
| Timer status register_1 | TSR_1 | 8 | H'FFFF8285 | | 8 | |
| Timer counter_1 | TCNT_1 | 16 | H'FFFF8286 | | 16 | |
| Timer general register A_1 | TGRA_1 | 16 | H'FFFF8288 | | 16, 32 | |
| Timer general register B_1 | TGRB_1 | 16 | H'FFFF828A | | 16 | |
| — | — | — | H'FFFF828C to H'FFFF829F | | — | |
| Timer control register_2 | TCR_2 | 8 | H'FFFF82A0 | MTU (Channel 2) | 8, 16 | |
| Timer mode register_2 | TMDR_2 | 8 | H'FFFF82A1 | MTU | 8 | |
| Timer I/O control register_2 | TIOR_2 | 8 | H'FFFF82A2 | (Channel 2) | 8 | |
| — | — | — | H'FFFF82A3 | | — | |
| Timer interrupt enable register_2 | TIER_2 | 8 | H'FFFF82A4 | | 8, 16, 32 | |
| Timer status register_2 | TSR_2 | 8 | H'FFFF82A5 | | 8 | |
| Timer counter_2 | TCNT_2 | 16 | H'FFFF82A6 | | 16 | |
| Timer general register A_2 | TGRA_2 | 16 | H'FFFF82A8 | | 16, 32 | |
| Timer general register B_2 | TGRB_2 | 16 | H'FFFF82AA | | 16 | |
| — | — | — | H'FFFF82AC to H'FFFF833F | | — | |

25. List of Registers

| Register name | abbreviation | NO. of bits | Address | Module | Access size | NO. of Access states |
|-------------------------------|--------------|-------------|-----------------------------|--------|-------------|----------------------|
| — | — | — | H'FFFF8340 to H'FFFF8347 | INTC | — | φ reference |
| Interrupt priority register A | IPRA | 16 | H'FFFF8348 | | 8, 16, 32 | B:2 |
| Interrupt priority register B | IPRB | 16 | H'FFFF834A | | 8, 16 | W:2 |
| Interrupt priority register C | IPRC | 16 | H'FFFF834C | | 8, 16, 32 | L:4 |
| Interrupt priority register D | IPRD | 16 | H'FFFF834E | | 8, 16 | |
| Interrupt priority register E | IPRE | 16 | H'FFFF8350 | | 8, 16, 32 | |
| Interrupt priority register F | IPRF | 16 | H'FFFF8352 | | 8, 16 | |
| Interrupt priority register G | IPRG | 16 | H'FFFF8354 | | 8, 16, 32 | |
| Interrupt priority register H | IPRH | 16 | H'FFFF8356 | | 8, 16 | |
| Interrupt control register1 | ICR1 | 16 | H'FFFF8358 | | 8, 16, 32 | |
| IRQ status register | ISR | 16 | H'FFFF835A | | 8, 16 | |
| Interrupt priority register I | IPRI | 16 | H'FFFF835C | | 8, 16, 32 | |
| Interrupt priority register J | IPRJ | 16 | H'FFFF835E | | 8, 16 | |
| — | — | — | H'FFFF8360 to H'FFFF8365 | | — | |
| Interrupt control register 2 | ICR2 | 16 | H'FFFF8366 | | 8, 16 | |
| — | — | — | H'FFFF8368 to H'FFFF837F | | — | |
| Port A data register H | PADRH | 16 | H'FFFF8380 | I/O | 8, 16, 32 | |
| Port A data register L | PADRL | 16 | H'FFFF8382 | | 8, 16 | |
| Port A I/O register H | PAIORH | 16 | H'FFFF8384 | PFC | 8, 16, 32 | |
| Port A I/O register L | PAIORL | 16 | H'FFFF8386 | | 8, 16 | |
| Port A control register H | PACRH | 16 | H'FFFF8388 | | 8, 16, 32 | |
| — | — | — | H'FFFF838A | | — | |
| Port A control register L1 | PACRL1 | 16 | H'FFFF838C | | 8, 16, 32 | |
| Port A control register L2 | PACRL2 | 16 | H'FFFF838E | | 8, 16 | |
| Port B data register | PBDR | 16 | H'FFFF8390 | I/O | 8, 16, 32 | |
| Port C data register | PCDR | 16 | H'FFFF8392 | | 8, 16 | |
| Port B I/O register | PBIOR | 16 | H'FFFF8394 | PFC | 8, 16, 32 | |
| Port C I/O register | PCIOR | 16 | H'FFFF8396 | | 8, 16 | |
| Port B control register 1 | PBCR1 | 16 | H'FFFF8398 | | 8, 16, 32 | |
| Port B control register 2 | PBCR2 | 16 | H'FFFF839A | | 8, 16 | |
| Port C control register 2 | PCCR | 16 | H'FFFF839C | | 8, 16, 32 | |

| Register name | abbreviation | NO. of bits | Address | Module | Access size | NO. of Access states |
|---------------------------------|--------------|-------------|---------------------------|--------|-------------|----------------------|
| — | — | — | H'FFF839E to H'FFF839F | — | — | φ reference B:2 |
| Port D data register H | PDDRH | 16 | H'FFF83A0 | I/O | 8, 16, 32 | W:2 |
| Port D data register L | PDDRL | 16 | H'FFF83A2 | | 8, 16 | L:4 |
| Port D I/O register H | PDIORH | 16 | H'FFF83A4 | PFC | 8, 16, 32 | |
| Port D I/O register L | PDIORL | 16 | H'FFF83A6 | | 8, 16 | |
| Port D control register H1 | PDCRH1 | 16 | H'FFF83A8 | | 8, 16, 32 | |
| Port D control register H2 | PDCRH2 | 16 | H'FFF83AA | | 8, 16 | |
| Port D control register L1 | PDCRL1 | 16 | H'FFF83AC | | 8, 16, 32 | |
| Port D control register L2 | PDCRL2 | 16 | H'FFF83AE | | 8, 16 | |
| Port E data register L | PEDRL | 16 | H'FFF83B0 | I/O | 8, 16, 32 | |
| — | — | — | H'FFF83B2 | — | — | |
| Port F data register | PFDR | 8 | H'FFF83B3 | I/O | 8 | |
| Port E I/O register L | PEIORL | 16 | H'FFF83B4 | PFC | 8, 16, 32 | |
| — | — | — | H'FFF83B6 to H'FFF83B7 | — | — | |
| Port E control register L1 | PECRL1 | 16 | H'FFF83B8 | PFC | 8, 16, 32 | |
| Port E control register L2 | PECRL2 | 16 | H'FFF83BA | | 8, 16 | |
| — | — | — | H'FFF83BC to H'FFF83BF | — | — | |
| Input control/status register 1 | ICSR1 | 16 | H'FFF83C0 | POE | 8, 16, 32 | |
| Output control/status register | OCSR | 16 | H'FFF83C2 | | 8, 16 | |
| — | — | — | H'FFF83C4 to H'FFF83CF | — | — | |

25. List of Registers

| Register name | abbreviation | NO. of bits | Address | Module | Access size | NO. of Access states |
|---|--------------|-------------|-----------------------------|------------|-------------|----------------------|
| Compare match timer start register | CMSTR | 16 | H'FFFF83D0 | CMT | 8, 16, 32 | P ϕ reference |
| Compare match timer control/ status register_0 | CMCSR_0 | 16 | H'FFFF83D2 | | 8, 16 | B:2 W:2 |
| Compare match timer counter_0 | CMCNT_0 | 16 | H'FFFF83D4 | | 8, 16, 32 | L:4 |
| Compare match timer constant register_0 | CMCOR_0 | 16 | H'FFFF83D6 | | 8, 16 | |
| Compare match timer control/ status register_1 | CMCSR_1 | 16 | H'FFFF83D8 | | 8, 16, 32 | |
| Compare match timer counter_1 | CMCNT_1 | 16 | H'FFFF83DA | | 8, 16 | |
| Compare match timer constant register_1 | CMCOR_1 | 16 | H'FFFF83DC | | 8, 16 | |
| — | — | — | H'FFFF83DE to H'FFFF841F | — | — | — |
| A/D data register 0 | ADDR0 | 16 | H'FFFF8420 | A/D | 8, 16 | P ϕ reference |
| A/D data register 1 | ADDR1 | 16 | H'FFFF8422 | (Channel0) | 8, 16 | B:3 |
| A/D data register 2 | ADDR2 | 16 | H'FFFF8424 | | 8, 16 | W:6 |
| A/D data register 3 | ADDR3 | 16 | H'FFFF8426 | | 8, 16 | |
| A/D data register 4 | ADDR4 | 16 | H'FFFF8428 | A/D | 8, 16 | |
| A/D data register 5 | ADDR5 | 16 | H'FFFF842A | (Channel1) | 8, 16 | |
| A/D data register 6 | ADDR6 | 16 | H'FFFF842C | | 8, 16 | |
| A/D data register 7 | ADDR7 | 16 | H'FFFF842E | | 8, 16 | |
| — | — | — | H'FFFF8430 to H'FFFF847F | — | — | — |
| A/D control/status register_0 | ADCSR_0 | 8 | H'FFFF8480 | A/D | 8, 16 | |
| A/D control/status register_1 | ADCSR_1 | 8 | H'FFFF8481 | | 8 | |
| — | — | — | H'FFFF8482 to H'FFFF8487 | — | — | — |
| A/D control register_0 | ADCR_0 | 8 | H'FFFF8488 | A/D | 8, 16 | |
| A/D control register_1 | ADCR_1 | 8 | H'FFFF8489 | | 8 | |
| — | — | — | H'FFFF848A to H'FFFF857F | — | — | — |

| Register name | abbreviation | NO. of bits | Address | Module | Access size | NO. of Access states |
|------------------------------------|----------------------|-------------|-----------------------------|--------------------------|-----------------------------------|----------------------|
| Flash memory control register 1 | FLMCR1 | 8 | H'FFFF8580 | FLASH | 8, 16 | φ reference |
| Flash memory control register 2 | FLMCR2 | 8 | H'FFFF8581 | (Only in F-ZTAT version) | 8 | B:3 |
| Erase block register 1 | EBR1 | 8 | H'FFFF8582 | | 8, 16 | W:6 |
| Erase block register 2 | EBR2 | 8 | H'FFFF8583 | | 8 | |
| — | — | — | H'FFFF8584 to H'FFFF85FF | | — | |
| User break address register H | UBARH | 16 | H'FFFF8600 | UBC | 8, 16, 32 | φ reference |
| User break address register L | UBARL | 16 | H'FFFF8602 | | 8, 16 | B:3 |
| User break address mask register H | UBAMRH | 16 | H'FFFF8604 | | 8, 16, 32 | W:3 |
| User break address mask register L | UBAMRL | 16 | H'FFFF8606 | | 8, 16 | L:6 |
| User break bus cycle register | UBBR | 16 | H'FFFF8608 | | 8, 16, 32 | |
| User break control register | UBCR | 16 | H'FFFF860A | | 8, 16 | |
| — | — | — | H'FFFF860C to H'FFFF860F | | — | |
| Timer control/status register | TCSR | 8 | H'FFFF8610 | WDT | 8 ^{*2} /16 ^{*1} | φ reference |
| Timer counter | TCNT ^{*1} | 8 | H'FFFF8610 | *1: Write | 16 | B:3 |
| Timer counter | TCNT ^{*2} | 8 | H'FFFF8611 | *2: Read | 8 | W:3 |
| Reset control/status register | RSTCSR ^{*1} | 8 | H'FFFF8612 | | 16 | |
| Reset control/status register | RSTCSR ^{*2} | 8 | H'FFFF8613 | | 8 | |
| Standby control register | SBYCR | 8 | H'FFFF8614 | Power-down modes | 8 | φ reference B:3 |
| — | — | — | H'FFFF8615 to H'FFFF8617 | — | — | — |
| System control register | SYSCR | 8 | H'FFFF8618 | Power-down modes | 8 | Pφ reference |
| — | — | — | H'FFFF8619 to H'FFFF861B | | — | B:3 W:3 |
| Module standby control register 1 | MSTCR1 | 16 | H'FFFF861C | | 8, 16, 32 | L:6 |
| Module standby control register 2 | MSTCR2 | 16 | H'FFFF861E | | 8, 16 | |

25. List of Registers

| Register name | abbreviation | NO. of bits | Address | Module | Access size | NO. of Access states |
|------------------------------------|--------------|-------------|-----------------------------|-----------------------------------|-------------|---------------------------|
| Bus control register 1 | BCR1 | 16 | H'FFFF8620 | BSC | 8, 16, 32 | φ reference |
| Bus control register 2 | BCR2 | 16 | H'FFFF8622 | | 8, 16 | B:3 |
| Wait control register 1 | WCR1 | 16 | H'FFFF8624 | | 8, 16, 32 | W:3 |
| Wait control register 2 | WCR2 | 16 | H'FFFF8626 | | 8, 16 | L:6 |
| RAM emulation register | RAMER | 16 | H'FFFF8628 | FLASH (Only in F-ZTAT version) | 8, 16 | φ reference B:3 W:3 |
| — | — | — | H'FFFF862A to H'FFFF86AF | — | — | — |
| DMA operation register | DMAOR | 16 | H'FFFF86B0 | DMAC (for all channels) | 8, 16 | φ reference W:3 L:6 |
| — | — | — | H'FFFF86B2 to H'FFFF86BF | | — | |
| DMA source address register_0 | SAR_0 | 32 | H'FFFF86C0 | DMAC | 8, 16, 32 | |
| DMA destination address register_0 | DAR_0 | 32 | H'FFFF86C4 | (Channel 0) | 8, 16, 32 | |
| DMA transfer count register_0 | DMATCR_0 | 32 | H'FFFF86C8 | | 8, 16, 32 | |
| DMA channel control register_0 | CHCR_0 | 32 | H'FFFF86CC | | 8, 16, 32 | |
| DMA source address register_1 | SAR_1 | 32 | H'FFFF86D0 | DMAC | 8, 16, 32 | |
| DMA destination address register_1 | DAR_1 | 32 | H'FFFF86D4 | (Channel 1) | 8, 16, 32 | |
| DMA transfer count register_1 | DMATCR_1 | 32 | H'FFFF86D8 | | 8, 16, 32 | |
| DMA channel control register_1 | CHCR_1 | 32 | H'FFFF86DC | | 8, 16, 32 | |
| DMA source address register_2 | SAR_2 | 32 | H'FFFF86E0 | DMAC | 8, 16, 32 | |
| DMA destination address register_2 | DAR_2 | 32 | H'FFFF86E4 | (Channel 2) | 8, 16, 32 | |
| DMA transfer count register_2 | DMATCR_2 | 32 | H'FFFF86E8 | | 8, 16, 32 | |
| DMA channel control register_2 | CHCR_2 | 32 | H'FFFF86EC | | 8, 16, 32 | |
| DMA source address register_3 | SAR_3 | 32 | H'FFFF86F0 | DMAC | 8, 16, 32 | |
| DMA destination address register_3 | DAR_3 | 32 | H'FFFF86F4 | (Channel 3) | 8, 16, 32 | |
| DMA transfer count register_3 | DMATCR_3 | 32 | H'FFFF86F8 | | 8, 16, 32 | |
| DMA channel control register_3 | CHCR_3 | 32 | H'FFFF86FC | | 8, 16, 32 | |

| Register name | abbreviation | NO. of bits | Address | Module | Access size | NO. of Access states |
|------------------------------------|--------------|-------------|-----------------------------|------------------------------|-------------|----------------------|
| DTC enable register A | DTEA | 8 | H'FFFF8700 | DTC | 8, 16, 32 | φ reference |
| DTC enable register B | DTEB | 8 | H'FFFF8701 | | 8 | B:3 |
| DTC enable register C | DTEC | 8 | H'FFFF8702 | | 8, 16 | W:3 |
| DTC enable register D | DTED | 8 | H'FFFF8703 | | 8 | L:6 |
| | — | — | H'FFFF8704 to H'FFFF8705 | | — | |
| DTC control/status register | DTCSR | 16 | H'FFFF8706 | | 8, 16, 32 | |
| DTC information base register | DTBR | 16 | H'FFFF8708 | | 8, 16 | |
| | — | — | H'FFFF870A to H'FFFF870F | | — | |
| DTC enable register E | DTEE | 8 | H'FFFF8710 | | 8, 16 | |
| — | — | — | H'FFFF8711 | | — | |
| DTC enable register G | DTEG | 8 | H'FFFF8712 | | 8, 16 | |
| — | — | — | H'FFFF8713 to H'FFFF87EF | | — | |
| Serial control register X | SCRX | 8 | H'FFFF87F0 | I ² C [Option] | 8 | Pφ reference B:3 |
| — | — | — | H'FFFF87F1 to H'FFFF87F3 | — | — | |
| AD trigger select register | ADTSR | 8 | H'FFFF87F4 | A/D | 8 | Pφ reference B:3 |
| — | — | — | H'FFFF87F5 to H'FFFF87F7 | — | — | |
| High-current port control register | PPCR | 8 | H'FFFF87F8 | Port E | 8 | Pφ reference B:3 |
| — | — | — | H'FFFF87F9 to H'FFFF8807 | — | — | |

25. List of Registers

| Register name | abbreviation | NO. of bits | Address | Module | Access size | NO. of Access states |
|---------------------------------------|--------------|-------------|-----------------------------|------------------------------|-------------|--------------------------|
| I ² C bus control register | ICCR | 8 | H'FFFF8808 | I ² C | 8, 16 | P _φ reference |
| I ² C bus status register | ICSR | 8 | H'FFFF8809 | [Option] | 8 | B:2 |
| — | — | — | H'FFFF880A to H'FFFF880D | — | — | W:4 |
| I ² C bus data register | ICDR | 8 | H'FFFF880E* | — | 8, 16 | — |
| Second slave address register | SARX | 8 | H'FFFF880E* | — | 8, 16 | — |
| I ² C bus mode register | ICMR | 8 | H'FFFF880F* | — | 8 | — |
| Slave address register | SAR | 8 | H'FFFF880F* | — | 8 | — |
| — | — | — | H'FFFF8810 to H'FFFF8A4F | — | — | — |
| Instruction register | SDIR | 16 | H'FFFF8A50 | H-UDI | 8, 16, 32 | P _φ reference |
| Status register | SDSR | 16 | H'FFFF8A52 | (Only in F- ZTAT version) | 8, 16 | B:2 |
| Data register H | SDDRH | 16 | H'FFFF8A54 | — | 8, 16, 32 | W:2 |
| Data register L | SDDRL | 16 | H'FFFF8A56 | — | 8, 16 | L:4 |
| — | — | — | H'FFFF8A58 to H'FFFFBFFF | — | — | — |

Note: * Registers that can be read from/written to differ according to the setting of the ICE bit in the IIC bus control register 0. In ICE=0, the registers read from/written to are the second slave address register 0 and the slave address register 0. In ICE=1, they are the IIC bus data register 0 and the IIC bus mode register 0.

25.2 Register Bit List

Addresses and bit names of each on-chip peripheral module are shown below.

As for 16-bit or 32-bit registers, they are shown in two or four rows.

| Register abbreviation | Bit7 | Bit6 | Bit5 | Bit4 | Bit3 | Bit2 | Bit1 | Bit0 | Module |
|-----------------------|--------------|------|------|--------------|------|------|------|------|-------------|
| SMR_0 | C/ \bar{A} | CHR | PE | O/ \bar{E} | STOP | MP | CKS1 | CKS0 | SCI |
| BRR_0 | | | | | | | | | (Channel 0) |
| SCR_0 | TIE | RIE | TE | RE | MPIE | TEIE | CKE1 | CKE0 | |
| TDR_0 | | | | | | | | | |
| SSR_0 | TDRE | RDRF | ORER | FER | PER | TEND | MPB | MPBT | |
| RDR_0 | | | | | | | | | |
| SDCR_0 | — | — | — | — | DIR | SINV | — | SMIF | |
| SMR_1 | C/ \bar{A} | CHR | PE | O/ \bar{E} | STOP | MP | CKS1 | CKS0 | SCI |
| BRR_1 | | | | | | | | | (Channel 1) |
| SCR_1 | TIE | RIE | TE | RE | MPIE | TEIE | CKE1 | CKE0 | |
| TDR_1 | | | | | | | | | |
| SSR_1 | TDRE | RDRF | ORER | FER | PER | TEND | MPB | MPBT | |
| RDR_1 | | | | | | | | | |
| SDCR_1 | — | — | — | — | DIR | SINV | — | SMIF | |
| SMR_2 | C/ \bar{A} | CHR | PE | O/ \bar{E} | STOP | MP | CKS1 | CKS0 | SCI |
| BRR_2 | | | | | | | | | (Channel 2) |
| SCR_2 | TIE | RIE | TE | RE | MPIE | TEIE | CKE1 | CKE0 | |
| TDR_2 | | | | | | | | | |
| SSR_2 | TDRE | RDRF | ORER | FER | PER | TEND | MPB | MPBT | |
| RDR_2 | | | | | | | | | |
| SDCR_2 | — | — | — | — | DIR | SINV | — | SMIF | |
| SMR_3 | C/ \bar{A} | CHR | PE | O/ \bar{E} | STOP | MP | CKS1 | CKS0 | SCI |
| BRR_3 | | | | | | | | | (Channel 3) |
| SCR_3 | TIE | RIE | TE | RE | MPIE | TEIE | CKE1 | CKE0 | |
| TDR_3 | | | | | | | | | |
| SSR_3 | TDRE | RDRF | ORER | FER | PER | TEND | MPB | MPBT | |
| RDR_3 | | | | | | | | | |
| SDCR_3 | — | — | — | — | DIR | SINV | — | SMIF | |
| — | — | — | — | — | — | — | — | — | — |

25. List of Registers

| Register abbreviation | Bit7 | Bit6 | Bit5 | Bit4 | Bit3 | Bit2 | Bit1 | Bit0 | Module |
|-----------------------|-------|-------|-------|-------|-------|-------|-------|-------|------------------------|
| TCR_3 | CCLR2 | CCLR1 | CCLR0 | CKEG1 | CKEG0 | TPSC2 | TPSC1 | TPSC0 | MTU (Channels 3, 4) |
| TCR_4 | CCLR2 | CCLR1 | CCLR0 | CKEG1 | CKEG0 | TPSC2 | TPSC1 | TPSC0 | |
| TMDR_3 | — | — | BFB | BFA | MD3 | MD2 | MD1 | MD0 | |
| TMDR_4 | — | — | BFB | BFA | MD3 | MD2 | MD1 | MD0 | |
| TIORH_3 | IOB3 | IOB2 | IOB1 | IOB0 | IOA3 | IOA2 | IOA1 | IOA0 | |
| TIORL_3 | IOD3 | IOD2 | IOD1 | IOD0 | IOC3 | IOC2 | IOC1 | IOC0 | |
| TIORH_4 | IOB3 | IOB2 | IOB1 | IOB0 | IOA3 | IOA2 | IOA1 | IOA0 | |
| TIORL_4 | IOD3 | IOD2 | IOD1 | IOD0 | IOC3 | IOC2 | IOC1 | IOC0 | |
| TIER_3 | TTGE | — | — | TCIEV | TGIED | TGIEC | TGIEB | TGIEA | |
| TIER_4 | TTGE | — | — | TCIEV | TGIED | TGIEC | TGIEB | TGIEA | |
| TOER | — | — | OE4D | OE4C | OE3D | OE4B | OE4A | OE3B | |
| TOCR | — | PSYE | — | — | — | — | OLSN | OLSP | |
| TGCR | — | BDC | N | P | FB | WF | VF | UF | |
| TCNT_3 | _____ | | | | | | | | |
| TCNT_4 | _____ | | | | | | | | |
| TCDR | _____ | | | | | | | | |
| TDDR | _____ | | | | | | | | |
| TGRA_3 | _____ | | | | | | | | |
| TGRB_3 | _____ | | | | | | | | |
| TGRA_4 | _____ | | | | | | | | |
| TGRB_4 | _____ | | | | | | | | |
| TCNTS | _____ | | | | | | | | |
| TCBR | _____ | | | | | | | | |

| Register abbreviation | Bit7 | Bit6 | Bit5 | Bit4 | Bit3 | Bit2 | Bit1 | Bit0 | Module |
|-----------------------|-------|-------|-------|-------|-------|-------|-------|-------|------------------------|
| TGRC_3 | | | | | | | | | MTU (Channels 3, 4) |
| TGRD_3 | | | | | | | | | |
| TGRC_4 | | | | | | | | | |
| TGRD_4 | | | | | | | | | |
| TSR_3 | TCFD | — | — | TCFV | TGFD | TGFC | TGFB | TGFA | |
| TSR_4 | TCFD | — | — | TCFV | TGFD | TGFC | TGFB | TGFA | |
| TSTR | CST4 | CST3 | — | — | — | CST2 | CST1 | CST0 | |
| TSYR | SYNC4 | SYNC3 | — | — | — | SYNC2 | SYNC1 | SYNC0 | |
| TCR_0 | CCLR2 | CCLR1 | CCLR0 | CKEG1 | CKEG0 | TPSC2 | TPSC1 | TPSC0 | MTU (Channel 0) |
| TMDR_0 | — | — | BFB | BFA | MD3 | MD2 | MD1 | MD0 | |
| TIORH_0 | IOB3 | IOB2 | IOB1 | IOB0 | IOA3 | IOA2 | IOA1 | IOA0 | |
| TIORL_0 | IOD3 | IOD2 | IOD1 | IOD0 | IOC3 | IOC2 | IOC1 | IOC0 | |
| TIER_0 | TTGE | — | — | TCIEV | TGIED | TGIEC | TGIEB | TGIEA | |
| TSR_0 | — | — | — | TCFV | TGFD | TGFC | TGFB | TGFA | |
| TCNT_0 | | | | | | | | | |
| TGRA_0 | | | | | | | | | |
| TGRB_0 | | | | | | | | | |
| TGRC_0 | | | | | | | | | |
| TGRD_0 | | | | | | | | | |

25. List of Registers

| Register abbreviation | Bit7 | Bit6 | Bit5 | Bit4 | Bit3 | Bit2 | Bit1 | Bit0 | Module |
|-----------------------|-------|-------|-------|-------|-------|-------|-------|-------|-------------|
| TCR_1 | — | CCLR1 | CCLR0 | CKEG1 | CKEG0 | TPSC2 | TPSC1 | TPSC0 | MTU |
| TMDR_1 | — | — | — | — | MD3 | MD2 | MD1 | MD0 | (Channel 1) |
| TIOR_1 | IOB3 | IOB2 | IOB1 | IOB0 | IOA3 | IOA2 | IOA1 | IOA0 | |
| TIER_1 | TTGE | — | TCIEU | TCIEV | — | — | TGIEB | TGIEA | |
| TSR_1 | TCFD | — | TCFU | TCFV | — | — | TGFB | TGFA | |
| TCNT_1 | _____ | | | | | | | | |
| TGRA_1 | _____ | | | | | | | | |
| TGRB_1 | _____ | | | | | | | | |
| TCR_2 | — | CCLR1 | CCLR0 | CKEG1 | CKEG0 | TPSC2 | TPSC1 | TPSC0 | MTU |
| TMDR_2 | — | — | — | — | MD3 | MD2 | MD1 | MD0 | (Channel 2) |
| TIOR_2 | IOB3 | IOB2 | IOB1 | IOB0 | IOA3 | IOA2 | IOA1 | IOA0 | |
| TIER_2 | TTGE | — | TCIEU | TCIEV | — | — | TGIEB | TGIEA | |
| TSR_2 | TCFD | — | TCFU | TCFV | — | — | TGFB | TGFA | |
| TCNT_2 | _____ | | | | | | | | |
| TGRA_2 | _____ | | | | | | | | |
| TGRB_2 | _____ | | | | | | | | |
| — | — | — | — | — | — | — | — | — | — |

| Register abbreviation | Bit7 | Bit6 | Bit5 | Bit4 | Bit3 | Bit2 | Bit1 | Bit0 | Module |
|-----------------------|---------|---------|---------|---------|----------|----------|----------|----------|--------|
| IPRA | IRQ0 | IRQ0 | IRQ0 | IRQ0 | IRQ1 | IRQ1 | IRQ1 | IRQ1 | INTC |
| | IRQ2 | IRQ2 | IRQ2 | IRQ2 | IRQ3 | IRQ3 | IRQ3 | IRQ3 | |
| IPRB | IRQ4 | IRQ4 | IRQ4 | IRQ4 | IRQ5 | IRQ5 | IRQ5 | IRQ5 | |
| | IRQ6 | IRQ6 | IRQ6 | IRQ6 | IRQ7 | IRQ7 | IRQ7 | IRQ7 | |
| IPRC | DMAC0 | DMAC0 | DMAC0 | DMAC0 | DMAC1 | DMAC1 | DMAC1 | DMAC1 | |
| | DMAC2 | DMAC2 | DMAC2 | DMAC2 | DMAC3 | DMAC3 | DMAC3 | DMAC3 | |
| IPRD | MTU0 | MTU0 | MTU0 | MTU0 | MTU0 | MTU0 | MTU0 | MTU0 | |
| | MTU1 | MTU1 | MTU1 | MTU1 | MTU1 | MTU1 | MTU1 | MTU1 | |
| IPRE | MTU2 | MTU2 | MTU2 | MTU2 | MTU2 | MTU2 | MTU2 | MTU2 | |
| | MTU3 | MTU3 | MTU3 | MTU3 | MTU3 | MTU3 | MTU3 | MTU3 | |
| IPRF | MTU4 | MTU4 | MTU4 | MTU4 | MTU4 | MTU4 | MTU4 | MTU4 | |
| | SCI0 | SCI0 | SCI0 | SCI0 | SCI1 | SCI1 | SCI1 | SCI1 | |
| IPRG | A/D0, 1 | A/D0, 1 | A/D0, 1 | A/D0, 1 | DTC | DTC | DTC | DTC | |
| | CMT0 | CMT0 | CMT0 | CMT0 | CMT1 | CMT1 | CMT1 | CMT1 | |
| IPRH | WDT | WDT | WDT | WDT | I/O(MTU) | I/O(MTU) | I/O(MTU) | I/O(MTU) | |
| | — | — | — | — | — | — | — | — | |
| ICR1 | NMIL | — | — | — | — | — | — | NMIE | |
| | IRQ0S | IRQ1S | IRQ2S | IRQ3S | IRQ4S | IRQ5S | IRQ6S | IRQ7S | |
| ISR | — | — | — | — | — | — | — | — | |
| | IRQ0F | IRQ1F | IRQ2F | IRQ3F | IRQ4F | IRQ5F | IRQ6F | IRQ7F | |
| IPRI | SCI2 | SCI2 | SCI2 | SCI2 | SCI3 | SCI3 | SCI3 | SCI3 | |
| | — | — | — | — | — | — | — | — | |
| IPRJ | — | — | — | — | — | — | — | — | |
| | IIC | IIC | IIC | IIC | — | — | — | — | |
| ICR2 | IRQ0ES1 | IRQ0ES0 | IRQ1ES1 | IRQ1ES0 | IRQ2ES1 | IRQ2ES0 | IRQ3ES1 | IRQ3ES0 | |
| | IRQ4ES1 | IRQ4ES0 | IRQ5ES1 | IRQ5ES0 | IRQ6ES1 | IRQ6ES0 | IRQ7ES1 | IRQ7ES0 | |
| — | — | — | — | — | — | — | — | — | — |

25. List of Registers

| Register abbreviation | Bit7 | Bit6 | Bit5 | Bit4 | Bit3 | Bit2 | Bit1 | Bit0 | Module |
|-----------------------|---------|----------|---------|----------|----------|----------|---------|---------|--------|
| PADRH | — | — | — | — | — | — | — | — | Port A |
| | PA23DR | PA22DR | PA21DR | PA20DR | PA19DR | PA18DR | PA17DR | PA16DR | |
| PADRL | PA15DR | PA14DR | PA13DR | PA12DR | PA11DR | PA10DR | PA9DR | PA8DR | |
| | PA7DR | PA6DR | PA5DR | PA4DR | PA3DR | PA2DR | PA1DR | PA0DR | |
| PAIORH | — | — | — | — | — | — | — | — | |
| | PA23IOR | PA22IOR | PA21IOR | PA20IOR | PA19IOR | PA18IOR | PA17IOR | PA16IOR | |
| PAIORL | PA15IOR | PA14IOR | PA13IOR | PA12IOR | PA11IOR | PA10IOR | PA9IOR | PA8IOR | |
| | PA7IOR | PA6IOR | PA5IOR | PA4IOR | PA3IOR | PA2IOR | PA1IOR | PA0IOR | |
| PACRH | — | PA23MD | — | PA22MD | — | PA21MD | — | PA20MD | |
| | PA19MD1 | PA19MD0 | PA18MD1 | PA18MD0 | — | PA17MD | PA16MD1 | PA16MD0 | |
| PACRL1 | — | PA15MD | — | PA14MD | — | PA13MD | — | PA12MD | |
| | — | PA11MD | — | PA10MD | PA9MD1 | PA9MD0 | PA8MD1 | PA8MD0 | |
| PACRL2 | PA7MD1 | PA7MD0 | PA6MD1 | PA6MD0 | PA5MD1 | PA5MD0 | — | PA4MD | |
| | — | PA3MD | PA2MD1 | PA2MD0 | — | PA1MD | — | PA0MD | |
| PBDR | — | — | — | — | — | — | PB9DR | PB8DR | Port B |
| | PB7DR | PB6DR | PB5DR | PB4DR | PB3DR | PB2DR | PB1DR | PB0DR | |
| PCDR | PC15DR | PC14DR | PC13DR | PC12DR | PC11DR | PC10DR | PC9DR | PC8DR | Port C |
| | PC7DR | PC6DR | PC5DR | PC4DR | PC3DR | PC2DR | PC1DR | PC0DR | |
| PBIOR | — | — | — | — | — | — | PB9IOR | PB8 IOR | Port B |
| | PB7IOR | PB6 IOR | PB5IOR | PB4 IOR | PB3 IOR | PB2 IOR | PB1 IOR | PB0 IOR | |
| PCIOR | PC15IOR | PC14 IOR | PC13IOR | PC12 IOR | PC11 IOR | PC10 IOR | PC9IOR | PC8 IOR | Port C |
| | PC7IOR | PC6 IOR | PC5IOR | PC4 IOR | PC3 IOR | PC2 IOR | PC1 IOR | PC0 IOR | |
| PBCR1 | — | — | — | — | PB3MD2 | PB2MD2 | — | — | Port B |
| | — | — | — | — | PB9MD1 | PB9MD0 | PB8MD1 | PB8MD0 | |
| PBCR2 | PB7MD1 | PB7MD0 | PB6MD1 | PB6MD0 | PB5MD1 | PB5MD0 | PB4MD1 | PB4MD0 | |
| | PB3MD1 | PB3MD0 | PB2MD1 | PB2MD0 | — | PB1MD | — | PB0MD | |
| PCCR | PC15MD | PC14MD | PC13MD | PC12MD | PC11MD | PC10MD | PC9MD | PC8MD | Port C |
| | PC7MD | PC6MD | PC5MD | PC4MD | PC3MD | PC2MD | PC1MD | PC0MD | |

| Register abbreviation | Bit7 | Bit6 | Bit5 | Bit4 | Bit3 | Bit2 | Bit1 | Bit0 | Module |
|-----------------------|---------|---------|---------|---------|---------|---------|---------|---------|--------|
| PDDRH | PD31DR | PD30DR | PD29DR | PD28DR | PD27DR | PD26DR | PD25DR | PD24DR | Port D |
| | PD23DR | PD22DR | PD21DR | PD20DR | PD19DR | PD18DR | PD17DR | PD16DR | |
| PDDRL | PD15DR | PD14DR | PD13DR | PD12DR | PD11DR | PD10DR | PD9DR | PD8DR | |
| | PD7DR | PD6DR | PD5DR | PD4DR | PD3DR | PD2DR | PD1DR | PD0DR | |
| PDIORH | PD31IOR | PD30IOR | PD29IOR | PD28IOR | PD27IOR | PD26IOR | PD25IOR | PD24IOR | |
| | PD23IOR | PD22IOR | PD21IOR | PD20IOR | PD19IOR | PD18IOR | PD17IOR | PD16IOR | |
| PDIORL | PD15IOR | PD14IOR | PD13IOR | PD12IOR | PD11IOR | PD10IOR | PD9IOR | PD8IOR | |
| | PD7IOR | PD6IOR | PD5IOR | PD4IOR | PD3IOR | PD2IOR | PD1IOR | PD0IOR | |
| PDCRH1 | PD31MD1 | PD31MD0 | PD30MD1 | PD30MD0 | PD29MD1 | PD29MD0 | PD28MD1 | PD28MD0 | |
| | PD27MD1 | PD27MD0 | PD26MD1 | PD26MD0 | PD25MD1 | PD25MD0 | PD24MD1 | PD24MD0 | |
| PDCRH2 | PD23MD1 | PD23MD0 | PD22MD1 | PD22MD0 | PD21MD1 | PD21MD0 | PD20MD1 | PD20MD0 | |
| | PD19MD1 | PD19MD0 | PD18MD1 | PD18MD0 | PD17MD1 | PD17MD0 | PD16MD1 | PD16MD0 | |
| PDCRL1 | PD15MD0 | PD14MD0 | PD13MD0 | PD12MD0 | PD11MD0 | PD10MD0 | PD9MD0 | PD8MD0 | |
| | PD7MD | PD6MD | PD5MD | PD4MD | PD3MD | PD2MD | PD1MD | PD0MD | |
| PDCRL2 | PD15MD1 | PD14MD1 | PD13MD1 | PD12MD1 | PD11MD1 | PD10MD1 | PD9MD1 | PD8MD1 | |
| | — | — | — | — | — | — | — | — | |
| PEDRL | PE15DR | PE14DR | PE13DR | PE12DR | PE11DR | PE10DR | PE9DR | PE8DR | Port E |
| | PE7DR | PE6DR | PE5DR | PE4DR | PE3DR | PE2DR | PE1DR | PE0DR | |
| PFDR | PF7DR | PF6DR | PF5DR | PF4DR | PF3DR | PF2DR | PF1DR | PF0DR | Port F |
| PEIORL | PE15IOR | PE14IOR | PE13IOR | PE12IOR | PE11IOR | PE10IOR | PE9IOR | PE8IOR | Port E |
| | PE7IOR | PE6IOR | PE5IOR | PE4IOR | PE3IOR | PE2IOR | PE1IOR | PE0IOR | |
| PECRL1 | PE15MD1 | PE15MD0 | PE14MD1 | PE14MD0 | PE13MD1 | PE13MD0 | PE12MD1 | PE12MD0 | |
| | PE11MD1 | PE11MD0 | PE10MD1 | PE10MD0 | PE9MD1 | PE9MD0 | PE8MD1 | PE8MD0 | |
| PECRL2 | PE7MD1 | PE7MD0 | PE6MD1 | PE6MD0 | PE5MD1 | PE5MD0 | PE4MD1 | PE4MD0 | |
| | PE3MD1 | PE3MD0 | PE2MD1 | PE2MD0 | PE1MD1 | PE1MD0 | PE0MD1 | PE0MD0 | |
| — | — | — | — | — | — | — | — | — | — |
| ICSR1 | POE3F | POE2F | POE1F | POE0F | — | — | — | PIE | MTU |
| | POE3M1 | POE3M0 | POE2M1 | POE2M0 | POE1M1 | POE1M0 | POE0M1 | POE0M0 | |
| OCSR | OSF | — | — | — | — | — | OCE | OIE | |
| | — | — | — | — | — | — | — | — | |
| — | — | — | — | — | — | — | — | — | — |

25. List of Registers

| Register abbreviation | Bit7 | Bit6 | Bit5 | Bit4 | Bit3 | Bit2 | Bit1 | Bit0 | Module |
|-----------------------|------|------|------|------|------|------|------|------|--------|
| CMSTR | — | — | — | — | — | — | — | — | CMT |
| | — | — | — | — | — | — | STR1 | STR0 | |
| CMCSR_0 | — | — | — | — | — | — | — | — | |
| | CMF | CMIE | — | — | — | — | CKS1 | CKS0 | |
| CMCNT_0 | | | | | | | | | |
| CMCOR_0 | | | | | | | | | |
| CMCSR_1 | — | — | — | — | — | — | — | — | |
| | CMF | CMIE | — | — | — | — | CKS1 | CKS0 | |
| CMCNT_1 | | | | | | | | | |
| CMCOR_1 | | | | | | | | | |
| — | — | — | — | — | — | — | — | — | — |
| ADDR0 | AD9 | AD8 | AD7 | AD6 | AD5 | AD4 | AD3 | AD2 | A/D |
| | AD1 | AD0 | — | — | — | — | — | — | |
| ADDR1 | AD9 | AD8 | AD7 | AD6 | AD5 | AD4 | AD3 | AD2 | |
| | AD1 | AD0 | — | — | — | — | — | — | |
| ADDR2 | AD9 | AD8 | AD7 | AD6 | AD5 | AD4 | AD3 | AD2 | |
| | AD1 | AD0 | — | — | — | — | — | — | |
| ADDR3 | AD9 | AD8 | AD7 | AD6 | AD5 | AD4 | AD3 | AD2 | |
| | AD1 | AD0 | — | — | — | — | — | — | |
| ADDR4 | AD9 | AD8 | AD7 | AD6 | AD5 | AD4 | AD3 | AD2 | |
| | AD1 | AD0 | — | — | — | — | — | — | |
| ADDR5 | AD9 | AD8 | AD7 | AD6 | AD5 | AD4 | AD3 | AD2 | |
| | AD1 | AD0 | — | — | — | — | — | — | |
| ADDR6 | AD9 | AD8 | AD7 | AD6 | AD5 | AD4 | AD3 | AD2 | |
| | AD1 | AD0 | — | — | — | — | — | — | |
| ADDR7 | AD9 | AD8 | AD7 | AD6 | AD5 | AD4 | AD3 | AD2 | |
| | AD1 | AD0 | — | — | — | — | — | — | |
| ADCSR_0 | ADF | ADIE | — | ADM | — | — | CH1 | CH0 | |
| ADCSR_1 | ADF | ADIE | — | ADM | — | — | CH1 | CH0 | |

| Register abbreviation | Bit7 | Bit6 | Bit5 | Bit4 | Bit3 | Bit2 | Bit1 | Bit0 | Module |
|-----------------------|-------|-------|--------|--------|--------|--------|---------|--------|--------------------------|
| ADCR_0 | TRGE | CKS1 | CKS0 | ADST | ADCS | — | — | — | A/D |
| ADCR_1 | TRGE | CKS1 | CKS0 | ADST | ADCS | — | — | — | |
| — | — | — | — | — | — | — | — | — | — |
| FLMCR1 | FWE | SWE | ESU | PSU | EV | PV | E | P | FLASH |
| FLMCR2 | FLER | — | — | — | — | — | — | — | (Only in F-ZTAT version) |
| EBR1 | EB7 | EB6 | EB5 | EB4 | EB3 | EB2 | EB1 | EB0 | |
| EBR2 | — | — | — | — | EB11 | EB10 | EB9 | EB8 | |
| — | — | — | — | — | — | — | — | — | — |
| UBARH | UBA31 | UBA30 | UBA29 | UBA28 | UBA27 | UBA26 | UBA25 | UBA24 | UBC |
| | UBA23 | UBA22 | UBA21 | UBA20 | UBA19 | UBA18 | UBA17 | UBA16 | |
| UBARL | UBA15 | UBA14 | UBA13 | UBA12 | UBA11 | UBA10 | UBA9 | UBA8 | |
| | UBA7 | UBA6 | UBA5 | UBA4 | UBA3 | UBA2 | UBA1 | UBA0 | |
| UBAMRH | UBM31 | UBM30 | UBM29 | UBM28 | UBM27 | UBM26 | UBM25 | UBM24 | |
| | UBM23 | UBM22 | UBM21 | UBM20 | UBM19 | UBM18 | UBM17 | UBM16 | |
| UBAMRL | UBM15 | UBM14 | UBM13 | UBM12 | UBM11 | UBM10 | UBM9 | UBM8 | |
| | UBM7 | UBM6 | UBM5 | UBM4 | UBM3 | UBM2 | UBM1 | UBM0 | |
| UBBR | — | — | — | — | — | — | — | — | |
| | CP1 | CP0 | ID1 | ID0 | RW1 | RW0 | SZ1 | SZ0 | |
| UBCR | — | — | — | — | — | — | — | — | |
| | — | — | — | — | — | — | — | UBID | |
| — | — | — | — | — | — | — | — | — | — |
| TCSR * ¹ | OVF | WT/IT | TME | — | — | CKS2 | CKS1 | CKS0 | WDT |
| TCNT * ¹ | | | | | | | | | *1: Write |
| TCNT * ² | | | | | | | | | *2: Read |
| RSTCSR* ¹ | | | | | | | | | |
| RSTCSR * ² | WOVF | RSTE | RSTS | — | — | — | — | — | |
| — | — | — | — | — | — | — | — | — | — |
| SBYCR | SSBY | HI-Z | — | — | — | — | IRQEH | IRQEL | Power-down |
| SYSCR | — | — | — | — | — | — | AUDSRST | RAME | modes |
| MSTCR1 | — | — | — | — | MSTP27 | MSTP26 | MSTP25 | MSTP24 | |
| | — | — | MSTP21 | — | MSTP19 | MSTP18 | MSTP17 | MSTP16 | |
| MSTCR2 | — | — | MSTP13 | MSTP12 | — | — | — | — | |
| | — | — | MSTP5 | MSTP4 | MSTP3 | MSTP2 | — | MSTP0 | |

25. List of Registers

| Register abbreviation | Bit7 | Bit6 | Bit5 | Bit4 | Bit3 | Bit2 | Bit1 | Bit0 | Module |
|-----------------------|------|------|--------|------|------|------|------|------|--------------------------|
| — | — | — | — | — | — | — | — | — | — |
| BCR1 | — | — | MTURWE | — | — | — | — | — | BSC |
| | A3LG | A2LG | A1LG | A0LG | A3SZ | A2SZ | A1SZ | A0SZ | |
| BCR2 | IW31 | IW30 | IW21 | IW20 | IW11 | IW10 | IW01 | IW00 | |
| | CW3 | CW2 | CW1 | CW0 | SW3 | SW2 | SW1 | SW0 | |
| WCR1 | W33 | W32 | W31 | W30 | W23 | W22 | W21 | W20 | |
| | W13 | W12 | W11 | W10 | W03 | W02 | W01 | W00 | |
| WCR2 | — | — | — | — | — | — | — | — | |
| | — | — | — | — | DSW3 | DSW2 | DSW1 | DSW0 | |
| — | — | — | — | — | — | — | — | — | — |
| RAMER | — | — | — | — | — | — | — | — | FLASH |
| | — | — | — | — | RAMS | RAM2 | RAM1 | RAM0 | (Only in F-ZTAT version) |
| — | — | — | — | — | — | — | — | — | — |
| DMAOR | — | — | — | — | — | — | PR1 | PR0 | DMAC |
| | — | — | — | — | — | AE | NMIF | DME | for all channels |
| SAR_0 | | | | | | | | | DMAC |
| | | | | | | | | | (Channel 0) |
| DAR_0 | | | | | | | | | |
| DMATCR_0 | — | — | — | — | — | — | — | — | |
| CHCR_0 | — | — | — | — | — | — | — | — | |
| | — | — | — | — | — | RL | AM | AL | |
| | DM1 | DM0 | SM1 | SM0 | RS3 | RS2 | RS1 | RS0 | |
| | — | DS | TM | TS1 | TS0 | IE | TE | DE | |

| Register abbreviation | Bit7 | Bit6 | Bit5 | Bit4 | Bit3 | Bit2 | Bit1 | Bit0 | Module |
|-----------------------|------|------|------|------|------|------|------|------|---------------------|
| SAR_1 | | | | | | | | | DMAC (Channel 1) |
| | | | | | | | | | |
| | | | | | | | | | |
| DAR_1 | | | | | | | | | |
| | | | | | | | | | |
| | | | | | | | | | |
| DMATCR_1 | — | — | — | — | — | — | — | — | |
| | | | | | | | | | |
| | | | | | | | | | |
| CHCR_1 | — | — | — | — | — | — | — | — | |
| | — | — | — | — | — | RL | AM | AL | |
| | DM1 | DM0 | SM1 | SM0 | RS3 | RS2 | RS1 | RS0 | |
| | — | DS | TM | TS1 | TS0 | IE | TE | DE | |
| SAR_2 | | | | | | | | | DMAC (Channel 2) |
| | | | | | | | | | |
| | | | | | | | | | |
| DAR_2 | | | | | | | | | |
| | | | | | | | | | |
| | | | | | | | | | |
| DMATCR_2 | — | — | — | — | — | — | — | — | |
| | | | | | | | | | |
| | | | | | | | | | |
| CHCR_2 | — | — | — | — | — | — | — | — | |
| | — | — | — | — | RO | — | — | — | |
| | DM1 | DM0 | SM1 | SM0 | RS3 | RS2 | RS1 | RS0 | |
| | — | — | TM | TS1 | TS0 | IE | TE | DE | |

25. List of Registers

| Register abbreviation | Bit7 | Bit6 | Bit5 | Bit4 | Bit3 | Bit2 | Bit1 | Bit0 | Module |
|-----------------------|--------|--------|--------|--------|--------|--------|--------|--------|---------------------------|
| SAR_3 | | | | | | | | | DMAC (Channel 3) |
| DAR_3 | | | | | | | | | |
| DMATCR_3 | — | — | — | — | — | — | — | — | |
| CHCR_3 | — | — | — | — | — | — | — | — | |
| | — | — | — | DI | — | — | — | — | |
| | DM1 | DM0 | SM1 | SM0 | RS3 | RS2 | RS1 | RS0 | |
| | — | — | TM | TS1 | TS0 | IE | TE | DE | |
| — | — | — | — | — | — | — | — | — | — |
| DTEA | DTEA7 | DTEA6 | DTEA5 | DTEA4 | DTEA3 | DTEA2 | DTEA1 | DTEA0 | DTC |
| DTEB | DTEB7 | DTEB6 | DTEB5 | DTEB4 | DTEB3 | DTEB2 | DTEB1 | DTEB0 | |
| DTEC | DTEC7 | DTEC6 | DTEC5 | DTEC4 | DTEC3 | DTEC2 | DTEC1 | DTEC0 | |
| DTED | DTED7 | DTED6 | DTED5 | DTED4 | DTED3 | DTED2 | DTED1 | DTED0 | |
| DTCSR | — | — | — | — | — | NMIF | AE | SWDTE | |
| | DTVEC7 | DTVEC6 | DTVEC5 | DTVEC4 | DTVEC3 | DTVEC2 | DTVEC1 | DTVEC0 | |
| DTBR | | | | | | | | | |
| DTEE | — | — | DTEE5 | — | DTEE3 | DTEE2 | DTEE1 | DTEE0 | |
| DTEG | DTEG7 | — | — | — | — | — | — | — | |
| — | — | — | — | — | — | — | — | — | — |
| SCRX | — | — | IICX | IICE | HNDS | — | ICDRF | STOPIM | I ² C [Option] |
| — | — | — | — | — | — | — | — | — | — |
| ADTSR | — | — | — | — | TRG1S1 | TRG1S0 | TRG0S1 | TRG0S0 | A/D |
| — | — | — | — | — | — | — | — | — | — |
| PPCR | — | — | — | — | — | — | — | MZIZE | Port E |
| — | — | — | — | — | — | — | — | — | — |

| Register abbreviation | Bit7 | Bit6 | Bit5 | Bit4 | Bit3 | Bit2 | Bit1 | Bit0 | Module |
|-----------------------|--------|--------|--------|--------|--------|--------|--------|-------|--------------------------------------|
| ICCR | ICE | IEIC | MST | TRS | ACKE | BBSY | IRIC | SCP | i ² C [Option] |
| ICSR | ESTP | STOP | IRTR | AASX | AL | AAS | ADZ | ACKB | |
| ICDR | ICDR7 | ICDR6 | ICDR5 | ICDR4 | ICDR3 | ICDR2 | ICDR1 | ICDR0 | |
| SARX | SVARX6 | SVARX5 | SVARX4 | SVARX3 | SVARX2 | SVARX1 | SVARX0 | FSX | |
| ICMR | MLS | WAIT | CKS2 | CKS1 | CKS0 | BC2 | BC1 | BC0 | |
| SAR | SVA6 | SVA5 | SVA4 | SVA3 | SVA2 | SVA1 | SVA0 | FS | |
| — | — | — | — | — | — | — | — | — | — |
| SDIR | TS3 | TS2 | TS1 | TS0 | — | — | — | — | H-UDI (Only in F-ZTAT version) |
| — | — | — | — | — | — | — | — | — | — |
| SDSR | — | — | — | — | — | — | — | — | — |
| — | — | — | — | — | — | — | — | SDTRF | — |
| SDDRH | — | — | — | — | — | — | — | — | — |
| — | — | — | — | — | — | — | — | — | — |
| SDDRL | — | — | — | — | — | — | — | — | — |

25.3 Register States in Each Operating Mode

| Register abbreviation | Power-on reset | Manual reset | Software Standby | Module Standby | Sleep | Module |
|-----------------------|----------------|--------------|------------------|----------------|----------|--------------------|
| SMR_0 | Initialized | Retained | Initialized | Initialized | Retained | SCI (Channel 0) |
| BRR_0 | Initialized | Retained | Initialized | Initialized | Retained | |
| SCR_0 | Initialized | Retained | Initialized | Initialized | Retained | |
| TDR_0 | Initialized | Retained | Initialized | Initialized | Retained | |
| SSR_0 | Initialized | Retained | Initialized | Initialized | Retained | |
| RDR_0 | Initialized | Retained | Initialized | Initialized | Retained | |
| SDCR_0 | Initialized | Retained | Initialized | Initialized | Retained | |
| SMR_1 | Initialized | Retained | Initialized | Initialized | Retained | SCI (Channel 1) |
| BRR_1 | Initialized | Retained | Initialized | Initialized | Retained | |
| SCR_1 | Initialized | Retained | Initialized | Initialized | Retained | |
| TDR_1 | Initialized | Retained | Initialized | Initialized | Retained | |
| SSR_1 | Initialized | Retained | Initialized | Initialized | Retained | |
| RDR_1 | Initialized | Retained | Initialized | Initialized | Retained | |
| SDCR_1 | Initialized | Retained | Initialized | Initialized | Retained | |
| SMR_2 | Initialized | Retained | Initialized | Initialized | Retained | SCI (Channel 2) |
| BRR_2 | Initialized | Retained | Initialized | Initialized | Retained | |
| SCR_2 | Initialized | Retained | Initialized | Initialized | Retained | |
| TDR_2 | Initialized | Retained | Initialized | Initialized | Retained | |
| SSR_2 | Initialized | Retained | Initialized | Initialized | Retained | |
| RDR_2 | Initialized | Retained | Initialized | Initialized | Retained | |
| SDCR_2 | Initialized | Retained | Initialized | Initialized | Retained | |
| SMR_3 | Initialized | Retained | Initialized | Initialized | Retained | SCI (Channel 3) |
| BRR_3 | Initialized | Retained | Initialized | Initialized | Retained | |
| SCR_3 | Initialized | Retained | Initialized | Initialized | Retained | |
| TDR_3 | Initialized | Retained | Initialized | Initialized | Retained | |
| SSR_3 | Initialized | Retained | Initialized | Initialized | Retained | |
| RDR_3 | Initialized | Retained | Initialized | Initialized | Retained | |
| SDCR_3 | Initialized | Retained | Initialized | Initialized | Retained | |

| Register abbreviation | Power-on reset | Manual reset | Software Standby | Module Standby | Sleep | Module |
|--------------------------|----------------|--------------|---------------------|-------------------|----------|------------------------|
| TCR_3 | Initialized | Retained | Initialized | Initialized | Retained | MTU (Channels 3, 4) |
| TCR_4 | Initialized | Retained | Initialized | Initialized | Retained | |
| TMDR_3 | Initialized | Retained | Initialized | Initialized | Retained | |
| TMDR_4 | Initialized | Retained | Initialized | Initialized | Retained | |
| TIORH_3 | Initialized | Retained | Initialized | Initialized | Retained | |
| TIORL_3 | Initialized | Retained | Initialized | Initialized | Retained | |
| TIORH_4 | Initialized | Retained | Initialized | Initialized | Retained | |
| TIORL_4 | Initialized | Retained | Initialized | Initialized | Retained | |
| TIER_3 | Initialized | Retained | Initialized | Initialized | Retained | |
| TIER_4 | Initialized | Retained | Initialized | Initialized | Retained | |
| TOER | Initialized | Retained | Initialized | Initialized | Retained | |
| TOCR | Initialized | Retained | Initialized | Initialized | Retained | |
| TGCR | Initialized | Retained | Initialized | Initialized | Retained | |
| TCNT_3 | Initialized | Retained | Initialized | Initialized | Retained | |
| TCNT_4 | Initialized | Retained | Initialized | Initialized | Retained | |
| TCDR | Initialized | Retained | Initialized | Initialized | Retained | |
| TDDR | Initialized | Retained | Initialized | Initialized | Retained | |
| TGRA_3 | Initialized | Retained | Initialized | Initialized | Retained | |
| TGRB_3 | Initialized | Retained | Initialized | Initialized | Retained | |
| TGRA_4 | Initialized | Retained | Initialized | Initialized | Retained | |
| TGRB_4 | Initialized | Retained | Initialized | Initialized | Retained | |
| TCNTS | Initialized | Retained | Initialized | Initialized | Retained | |
| TCBR | Initialized | Retained | Initialized | Initialized | Retained | |
| TGRC_3 | Initialized | Retained | Initialized | Initialized | Retained | |
| TGRD_3 | Initialized | Retained | Initialized | Initialized | Retained | |
| TGRC_4 | Initialized | Retained | Initialized | Initialized | Retained | |
| TGRD_4 | Initialized | Retained | Initialized | Initialized | Retained | |
| TSR_3 | Initialized | Retained | Initialized | Initialized | Retained | |
| TSR_4 | Initialized | Retained | Initialized | Initialized | Retained | |
| TSTR | Initialized | Retained | Initialized | Initialized | Retained | |
| TSYR | Initialized | Retained | Initialized | Initialized | Retained | |

25. List of Registers

| Register abbreviation | Power-on reset | Manual reset | Software Standby | Module Standby | Sleep | Module | |
|--------------------------|----------------|--------------|---------------------|-------------------|----------|--------------------|--------------------|
| TCR_0 | Initialized | Retained | Initialized | Initialized | Retained | MTU (Channel 0) | |
| TMDR_0 | Initialized | Retained | Initialized | Initialized | Retained | | |
| TIORH_0 | Initialized | Retained | Initialized | Initialized | Retained | | |
| TIORL_0 | Initialized | Retained | Initialized | Initialized | Retained | | |
| TIER_0 | Initialized | Retained | Initialized | Initialized | Retained | | |
| TSR_0 | Initialized | Retained | Initialized | Initialized | Retained | | |
| TCNT_0 | Initialized | Retained | Initialized | Initialized | Retained | | |
| TGRA_0 | Initialized | Retained | Initialized | Initialized | Retained | | |
| TGRB_0 | Initialized | Retained | Initialized | Initialized | Retained | | |
| TGRC_0 | Initialized | Retained | Initialized | Initialized | Retained | | |
| TGRD_0 | Initialized | Retained | Initialized | Initialized | Retained | | |
| TCR_1 | Initialized | Retained | Initialized | Initialized | Retained | | MTU (Channel 1) |
| TMDR_1 | Initialized | Retained | Initialized | Initialized | Retained | | |
| TIOR_1 | Initialized | Retained | Initialized | Initialized | Retained | | |
| TIER_1 | Initialized | Retained | Initialized | Initialized | Retained | | |
| TSR_1 | Initialized | Retained | Initialized | Initialized | Retained | | |
| TCNT_1 | Initialized | Retained | Initialized | Initialized | Retained | | |
| TGRA_1 | Initialized | Retained | Initialized | Initialized | Retained | | |
| TGRB_1 | Initialized | Retained | Initialized | Initialized | Retained | | |
| TCR_2 | Initialized | Retained | Initialized | Initialized | Retained | MTU (Channel 2) | |
| TMDR_2 | Initialized | Retained | Initialized | Initialized | Retained | | |
| TIOR_2 | Initialized | Retained | Initialized | Initialized | Retained | | |
| TIER_2 | Initialized | Retained | Initialized | Initialized | Retained | | |
| TSR_2 | Initialized | Retained | Initialized | Initialized | Retained | | |
| TCNT_2 | Initialized | Retained | Initialized | Initialized | Retained | | |
| TGRA_2 | Initialized | Retained | Initialized | Initialized | Retained | | |
| TGRB_2 | Initialized | Retained | Initialized | Initialized | Retained | | |

| Register abbreviation | Power-on reset | Manual reset | Software Standby | Module Standby | Sleep | Module |
|-----------------------|----------------|--------------|------------------|----------------|----------|--------|
| IPRA | Initialized | Initialized | Retained | — | Retained | INTC |
| IPRB | Initialized | Initialized | Retained | — | Retained | |
| IPRC | Initialized | Initialized | Retained | — | Retained | |
| IPRD | Initialized | Initialized | Retained | — | Retained | |
| IPRE | Initialized | Initialized | Retained | — | Retained | |
| IPRF | Initialized | Initialized | Retained | — | Retained | |
| IPRG | Initialized | Initialized | Retained | — | Retained | |
| IPRH | Initialized | Initialized | Retained | — | Retained | |
| ICR1 | Initialized | Initialized | Retained | — | Retained | |
| ISR | Initialized | Initialized | Retained | — | Retained | |
| IPRI | Initialized | Initialized | Retained | — | Retained | |
| IPRJ | Initialized | Initialized | Retained | — | Retained | |
| ICR2 | Initialized | Initialized | Retained | — | Retained | |
| PADRH | Initialized | Retained | Retained | — | Retained | Port A |
| PADRL | Initialized | Retained | Retained | — | Retained | |
| PAIORH | Initialized | Retained | Retained | — | Retained | |
| PAIORL | Initialized | Retained | Retained | — | Retained | |
| PACRH | Initialized | Retained | Retained | — | Retained | |
| PACRL1 | Initialized | Retained | Retained | — | Retained | |
| PACRL2 | Initialized | Retained | Retained | — | Retained | |
| PBDR | Initialized | Retained | Retained | — | Retained | Port B |
| PCDR | Initialized | Retained | Retained | — | Retained | Port C |
| PBIOR | Initialized | Retained | Retained | — | Retained | Port B |
| PCIOR | Initialized | Retained | Retained | — | Retained | Port C |
| PBCR1 | Initialized | Retained | Retained | — | Retained | Port B |
| PBCR2 | Initialized | Retained | Retained | — | Retained | |
| PCCR | Initialized | Retained | Retained | — | Retained | Port C |

25. List of Registers

| Register abbreviation | Power-on reset | Manual reset | Software Standby | Module Standby | Sleep | Module |
|-----------------------|----------------|--------------|------------------|----------------|----------|--------|
| PDDRH | Initialized | Retained | Retained | — | Retained | Port D |
| PDDRL | Initialized | Retained | Retained | — | Retained | |
| PDIORH | Initialized | Retained | Retained | — | Retained | |
| PDIORL | Initialized | Retained | Retained | — | Retained | |
| PDCRH1 | Initialized | Retained | Retained | — | Retained | |
| PDCRH2 | Initialized | Retained | Retained | — | Retained | |
| PDCRL1 | Initialized | Retained | Retained | — | Retained | |
| PDCRL2 | Initialized | Retained | Retained | — | Retained | |
| PEDRL | Initialized | Retained | Retained | — | Retained | Port E |
| PFDR | Retained | Retained | Retained | — | Retained | Port F |
| PEIORL | Initialized | Retained | Retained | — | Retained | Port E |
| PECRL1 | Initialized | Retained | Retained | — | Retained | |
| PECRL2 | Initialized | Retained | Retained | — | Retained | |
| ICSR1 | Initialized | Retained | Retained | Retained | Retained | POE |
| OCSR | Initialized | Retained | Retained | Retained | Retained | |
| CMSTR | Initialized | Retained | Initialized | Initialized | Retained | CMT |
| CMCSR_0 | Initialized | Retained | Initialized | Initialized | Retained | |
| CMCNT_0 | Initialized | Retained | Initialized | Initialized | Retained | |
| CMCOR_0 | Initialized | Retained | Initialized | Initialized | Retained | |
| CMCSR_1 | Initialized | Retained | Initialized | Initialized | Retained | |
| CMCNT_1 | Initialized | Retained | Initialized | Initialized | Retained | |
| CMCOR_1 | Initialized | Retained | Initialized | Initialized | Retained | |
| ADDR0 | Initialized | Retained | Initialized | Initialized | Retained | A/D |
| ADDR1 | Initialized | Retained | Initialized | Initialized | Retained | |
| ADDR2 | Initialized | Retained | Initialized | Initialized | Retained | |
| ADDR3 | Initialized | Retained | Initialized | Initialized | Retained | |
| ADDR4 | Initialized | Retained | Initialized | Initialized | Retained | |
| ADDR5 | Initialized | Retained | Initialized | Initialized | Retained | |
| ADDR6 | Initialized | Retained | Initialized | Initialized | Retained | |
| ADDR7 | Initialized | Retained | Initialized | Initialized | Retained | |
| ADCSR_0 | Initialized | Retained | Initialized | Initialized | Retained | |

| Register abbreviation | Power-on reset | Manual reset | Software Standby | Module Standby | Sleep | Module |
|--------------------------|---------------------------|------------------------|---------------------|-------------------|----------|--------------------------------------|
| ADCSR_1 | Initialized | Retained | Initialized | Initialized | Retained | A/D |
| ADCF_0 | Initialized | Retained | Initialized | Initialized | Retained | |
| ADCR_1 | Initialized | Retained | Initialized | Initialized | Retained | |
| FLMCR1 | Initialized | Retained | Initialized | Initialized | Retained | FLASH |
| FLMCR2 | Initialized | Retained | Initialized | Initialized | Retained | (Only in F-ZTAT version) |
| EBR1 | Initialized | Retained | Initialized | Initialized | Retained | |
| EBR2 | Initialized | Retained | Initialized | Initialized | Retained | |
| UBARH | Initialized | Retained | Retained | Initialized | Retained | UBC |
| UBARL | Initialized | Retained | Retained | Initialized | Retained | |
| UBAMRH | Initialized | Retained | Retained | Initialized | Retained | |
| UBAMRL | Initialized | Retained | Retained | Initialized | Retained | |
| UBBR | Initialized | Retained | Retained | Initialized | Retained | |
| UBCR | Initialized | Retained | Retained | Initialized | Retained | |
| TCSR | Initialized | Retained* ¹ | Retained | — | Retained | WDT |
| TCNT | Initialized | Retained* ¹ | Retained | — | Retained | |
| RSTCSR | Initialized* ² | Retained | Initialized | — | Retained | |
| SBYCR | Initialized | Retained* ¹ | Retained | — | Retained | Power-down modes |
| SYSCR | Initialized | Retained | Retained | — | Retained | |
| MSTCR1 | Initialized | Retained | Retained | — | Retained | |
| MSTCR2 | Initialized | Retained | Retained | — | Retained | |
| BCR1 | Initialized | Retained | Retained | — | Retained | BSC |
| BCR2 | Initialized | Retained | Retained | — | Retained | |
| WCR1 | Initialized | Retained | Retained | — | Retained | |
| WCR2 | Initialized | Retained | Retained | — | Retained | |
| RAMER | Initialized | Retained | Retained | — | Retained | FLASH (Only in F-ZTAT version) |
| DMAOR | Initialized | Retained | Initialized | Initialized | Retained | DMAC (for all channels) |
| SAR_0 | Initialized | Retained | Initialized | Initialized | Retained | DMAC |
| DAR_0 | Initialized | Retained | Initialized | Initialized | Retained | (Channel 0) |
| DMATCR_0 | Initialized | Retained | Initialized | Initialized | Retained | |
| CHCR_0 | Initialized | Retained | Initialized | Initialized | Retained | |

25. List of Registers

| Register abbreviation | Power-on reset | Manual reset | Software Standby | Module Standby | Sleep | Module |
|-----------------------|----------------|--------------|------------------|----------------|----------|---------------------------|
| SAR_1 | Initialized | Retained | Initialized | Initialized | Retained | DMAC |
| DAR_1 | Initialized | Retained | Initialized | Initialized | Retained | (Channel 1) |
| DMATCR_1 | Initialized | Retained | Initialized | Initialized | Retained | |
| CHCR_1 | Initialized | Retained | Initialized | Initialized | Retained | |
| SAR_2 | Initialized | Retained | Initialized | Initialized | Retained | DMAC |
| DAR_2 | Initialized | Retained | Initialized | Initialized | Retained | (Channel 2) |
| DMATCR_2 | Initialized | Retained | Initialized | Initialized | Retained | |
| CHCR_2 | Initialized | Retained | Initialized | Initialized | Retained | |
| SAR_3 | Initialized | Retained | Initialized | Initialized | Retained | DMAC |
| DAR_3 | Initialized | Retained | Initialized | Initialized | Retained | (Channel 3) |
| DMATCR_3 | Initialized | Retained | Initialized | Initialized | Retained | |
| CHCR_3 | Initialized | Retained | Initialized | Initialized | Retained | |
| DTEA | Initialized | Retained | Initialized | Initialized | Retained | DTC |
| DTEB | Initialized | Retained | Initialized | Initialized | Retained | |
| DTEC | Initialized | Retained | Initialized | Initialized | Retained | |
| DTED | Initialized | Retained | Initialized | Initialized | Retained | |
| DTCSR | Initialized | Retained | Initialized | Initialized | Retained | |
| DTBR | Retained | Retained | Retained | Retained | Retained | |
| DTEE | Initialized | Retained | Initialized | Initialized | Retained | |
| DTEG | Initialized | Retained | Initialized | Initialized | Retained | |
| SCRX | Initialized | Retained | Retained | Retained | Retained | I ² C [Option] |
| ADTSR | Initialized | Retained | Retained | Retained | Retained | A/D |
| PPCR | Initialized | Retained | Retained | — | Retained | Port E |
| ICCR | Initialized | Retained | Retained | Retained | Retained | I ² C [Option] |
| ICSR | Initialized | Retained | Retained | Retained | Retained | |
| ICDR | Initialized | Retained | Retained | Retained | Retained | |
| SARX | Initialized | Retained | Retained | Retained | Retained | |
| ICMR | Initialized | Retained | Retained | Retained | Retained | |
| SAR | Initialized | Retained | Retained | Retained | Retained | |
| SDIR | Initialized | Retained | Retained | Retained | Retained | H-UDI |
| SDSR | Initialized | Retained | Retained | Retained | Retained | (Only in F-ZTAT version) |
| SDDRH | Retained | Retained | Retained | Retained | Retained | |
| SDDRL | Retained | Retained | Retained | Retained | Retained | |

- Notes:
1. Initialized by internal manual reset due to WDT overflow.
 2. Not initialized by internal power-on reset due to WDT overflow.

Section 26 Electrical Characteristics

26.1 Absolute Maximum Ratings

Table 26.1 shows the absolute maximum ratings.

Table 26.1 Absolute Maximum Ratings

| Item | | Symbol | Rating | Unit |
|---|---------------------------------------|-------------|-------------------------|------|
| Power supply voltage | | V_{CC} | -0.3 to +4.3 | V |
| Input voltage | All pins other than analog input pins | V_{in} | -0.3 to $V_{CC} + 0.3$ | V |
| | Analog input pins | V_{in} | -0.3 to $AV_{CC} + 0.3$ | V |
| Analog supply voltage | | AV_{CC} | -0.3 to +4.3 | V |
| Analog reference voltage (Only in SH7145) | | AV_{ref} | -0.3 to $AV_{CC} + 0.3$ | V |
| Analog input voltage | | V_{AN} | -0.3 to $AV_{CC} + 0.3$ | V |
| Operating temperature (except programming or erasing flash memory) | Regular specifications | T_{opr} | -20 to +75 | °C |
| | Wide range specifications | | -40 to +85 | |
| Operating temperature (programming or erasing flash memory) | | T_{WEopr} | -20 to +75 | °C |
| Storage temperature | | T_{stg} | -55 to +125 | °C |

[Operating Precautions]

Operating the LSI in excess of the absolute maximum ratings may result in permanent damage.

26.2 DC Characteristics

Table 26.2 DC Characteristics

Conditions: $V_{CC} = PLLV_{CC} = 3.3 \text{ V} \pm 0.3 \text{ V}$, $AV_{CC} = 3.3 \text{ V} \pm 0.3 \text{ V}$, $V_{CC} = V_{CC} \pm 0.3 \text{ V}$,
 $AV_{ref} = 3.0 \text{ V}$ to AV_{CC} , $V_{SS} = PLLV_{SS} = AV_{SS} = 0 \text{ V}$, $T_a = -20^\circ\text{C}$ to $+75^\circ\text{C}$
 (regular specifications), $T_a = -40^\circ\text{C}$ to $+85^\circ\text{C}$ (wide-range specifications),
 When programming or erasing flash memory, $T_a = -20^\circ\text{C}$ to $+75^\circ\text{C}$.

| Item | Symbol | Min. | Typ. | Max. | Unit | Measurement Conditions |
|---|---|--------------------------|--------------|------|---------------|----------------------------------|
| Input high-level voltage (except Schmitt trigger input voltage) | \overline{RES} , \overline{MRES} , NMI, FWP, MD3 to MD0, DBGMD | V_{IH} | $V_{CC}-0.5$ | — | $V_{CC}+0.3$ | V |
| | EXTAL | | $V_{CC}-0.5$ | — | $V_{CC}+0.3$ | V |
| | A/D port | | 2.2 | — | $AV_{CC}+0.3$ | V |
| | Other input pins | | 2.2 | — | $V_{CC}+0.3$ | V |
| Input low-level voltage (except Schmitt trigger input voltage) | \overline{RES} , \overline{MRES} , NMI, FWP, MD3 to MD0, EXTAL, DBGMD | V_{IL} | -0.3 | — | 0.5 | V |
| | Other input pins | | -0.3 | — | 0.8 | V |
| Schmitt trigger input voltage | $\overline{IRQ7}$ to $\overline{IRQ0}$, $\overline{POE3}$ to $\overline{POE0}$, TCLKA to TCLKD, TIOC0A to TIOC0D, TIOC1A, TIOC1B, TIOC2A, TIOC2B, TIOC3A to TIOC3D, TIOC4A to TIOC4D, SCK3 to SCK0, RXD3 to RXD0 | V_{T+} (V_{IH}) | $V_{CC}-0.5$ | — | — | V |
| | | V_{T-} (V_{IL}) | — | — | 0.5 | V |
| | | $V_{T+}-V_{T-}$ | 0.2 | — | — | V |
| Input leak current | \overline{RES} , \overline{MRES} , NMI, FWP, MD3 to MD0, DBGMD | $ I_{in} $ | — | — | 1.0 | μA |
| | A/D port | | — | — | 1.0 | μA |
| | Other input pins | | — | — | 1.0 | μA |
| Three-state leak current (OFF state) | port A, B, C, D, E, | $ I_{ISI} $ | — | — | 1.0 | μA |
| Output high-level voltage | All output pins | V_{OH} | $V_{CC}-0.5$ | — | — | V $I_{OH} = -200 \mu\text{A}$ |
| Output low-level voltage | All output pins | V_{OL} | — | — | 0.4 | V $I_{OL} = 1.6 \text{ mA}$ |
| | PE9, PE11 to PE15 | | — | — | 0.8 | V $I_{OL} = 15 \text{ mA}$ |

| Item | | Symbol | Min. | Typ. | Max. | Unit | Measurement Conditions | |
|--------------------------------|----------------------------|-------------|----------|------|------|---------------|--------------------------|--|
| Input capacitance | $\overline{\text{RES}}$ | C_{in} | — | — | 20 | pF | $V_{in} = 0\text{ V}$ | |
| | NMI | | — | — | 20 | pF | $f = 1\text{ MHz}$ | |
| | All other input pins | | — | — | 20 | pF | $T_a = 25^\circ\text{C}$ | |
| Current consumption*2 | Normal operation | Clock 1:1 | I_{CC} | — | 150 | 210 | mA | $f = 40\text{ MHz}$ |
| | | Clock 1:1/2 | | — | 160 | 220 | mA | $f = 50\text{ MHz}$ |
| | Sleep | Clock 1:1 | | — | 110 | 170 | mA | $f = 40\text{ MHz}$ |
| | | Clock 1:1/2 | | — | 120 | 180 | mA | $f = 50\text{ MHz}$ |
| | Standby | | | — | 3 | 50 | μA | $T_a \leq 50^\circ\text{C}$ |
| | | | | — | — | 500 | μA | $50^\circ\text{C} < T_a$ |
| | Flash programming | Clock 1:1 | | — | 150 | 210 | mA | $V_{CC} = 3.3\text{ V}$ $f = 40\text{ MHz}$ |
| | | Clock 1:1/2 | | — | 160 | 220 | mA | $V_{CC} = 3.3\text{ V}$ $f = 50\text{ MHz}$ |
| Analog Power supply current | During A/D conversion | I_{CC} | — | 2 | 5 | mA | | |
| | Waiting for A/D conversion | | — | — | 2 | mA | | |
| | Standby | | — | — | 5 | μA | | |
| Reference power supply current | During A/D conversion | I_{ref} | — | — | 2 | mA | | |
| | Waiting for A/D conversion | | — | — | 2 | mA | | |
| | Standby | | — | — | 5 | μA | | |
| RAM standby voltage | | V_{RAM} | 2.0 | — | — | V | V_{CC} | |

[Operating Precautions]

1. When the A/D converter is not used, do not leave the AV_{CC} , and AV_{SS} pins open.
2. The current consumption is measured when $V_{IHmin} = V_{CC} - 0.5\text{ V}$, $V_{IL} = 0.5\text{ V}$, with all output pins unloaded.

Table 26.3 Permitted Output Current Values

Conditions: $V_{CC} = PLLV_{CC} = 3.3 \text{ V} \pm 0.3 \text{ V}$, $AV_{CC} = 3.3 \text{ V} \pm 0.3 \text{ V}$, $AV_{CC} = V_{CC} \pm 0.3 \text{ V}$,
 $AV_{ref} = 3.0 \text{ V}$ to AV_{CC} , $V_{SS} = PLLV_{SS} = AV_{SS} = 0 \text{ V}$, $T_a = -20^\circ\text{C}$ to $+75^\circ\text{C}$
 (regular specifications), $T_a = -40^\circ\text{C}$ to $+85^\circ\text{C}$ (wide-range specifications),
 When programming or erasing flash memory, $T_a = -20^\circ\text{C}$ to $+75^\circ\text{C}$.

| Item | Symbol | Min. | Typ. | Max. | Unit |
|---|------------------|------|------|------|------|
| Output low-level permissible current (per pin) | I_{OL} | — | — | 2.0* | mA |
| Output low-level permissible current (total) | ΣI_{OL} | — | — | 80 | mA |
| Output high-level permissible current (per pin) | $-I_{OH}$ | — | — | 2.0 | mA |
| Output high-level permissible current (total) | $\Sigma -I_{OH}$ | — | — | 25 | mA |

[Operating Precautions]

To assure LSI reliability, do not exceed the output values listed in this table.

Note: * $I_{OL} = 15\text{mA}$ (max) about the pins PE9, PE11 to PE15. However, at least three pins are permitted to have simultaneously $I_{OL} \geq 2.0 \text{ mA}$ among these pins.

26.3 AC Characteristics

26.3.1 Test conditions for the AC characteristics

Input reference levels high level: V_{IH} minimum value, low level: V_{IL} maximum value

Output reference levels high level: 2.0 V, low level: 0.8 V

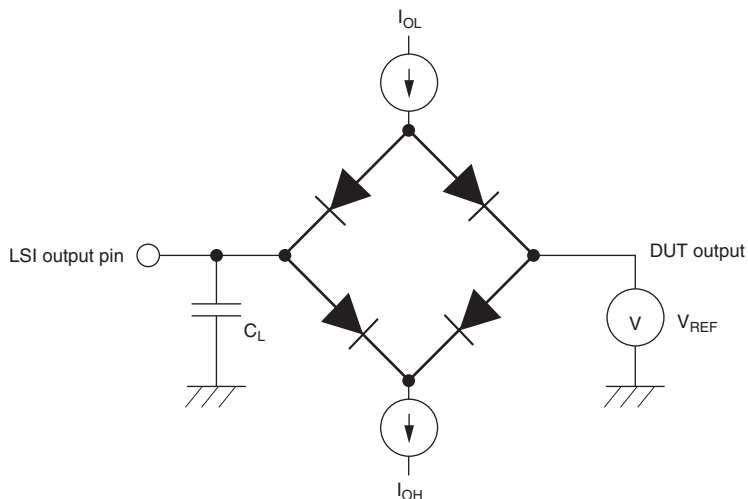

C_L is a total value that includes the capacitance of measurement equipment, and is set as follows:

30 pF: \overline{CK} , $\overline{CS7}$ to $\overline{CS0}$, \overline{BREQ} , \overline{BACK} , $\overline{DACK1}$, $\overline{DACK0}$, \overline{IRQOUT} , \overline{AUDCK}

50 pF: $\overline{A21}$ to $\overline{A0}$, $\overline{D31}$ to $\overline{D0}$, \overline{RD} , \overline{WRxx} , \overline{TDO}

100 pF: $\overline{AUDATA3}$ to $\overline{AUDATA0}$, $\overline{AUDSYNC}$

70 pF: Port output pin other than the above and peripheral module output pins

It is assumed that $I_{OL} = 1.6 \text{ mA}$, $I_{OH} = 200 \mu\text{A}$ in the test conditions.

Figure 26.1 Output Load Circuit

26.3.2 Clock timing

Table 26.4 shows the clock timing.

Table 26.4 Clock Timing

Conditions: $V_{CC} = PLLV_{CC} = 3.3 \text{ V} \pm 0.3 \text{ V}$, $AV_{CC} = 3.3 \text{ V} \pm 0.3 \text{ V}$, $AV_{CC} = V_{CC} \pm 0.3 \text{ V}$,
 $AV_{ref} = 3.0 \text{ V}$ to AV_{CC} , $V_{SS} = PLLV_{SS} = AV_{SS} = 0 \text{ V}$, $T_a = -20^\circ\text{C}$ to $+75^\circ\text{C}$
 (regular specifications), $T_a = -40^\circ\text{C}$ to $+85^\circ\text{C}$ (wide-range specifications),
 When programming or erasing flash memory, $T_a = -20^\circ\text{C}$ to $+75^\circ\text{C}$.

| Item | Symbol | Min. | Max. | Unit | Figure |
|--|-------------|-------------------|------|------|-------------|
| Operating frequency | f_{op} | 4 | 50 | MHz | Figure 26.2 |
| Clock cycle time | t_{cyc} | 20 | 250 | ns | |
| Clock low-level pulse width | t_{CL} | $1/2 t_{cyc} - 5$ | — | ns | |
| Clock high-level pulse width | t_{CH} | $1/2 t_{cyc} - 5$ | — | ns | |
| Clock rise time | t_{CR} | — | 5 | ns | |
| Clock fall time | t_{CF} | — | 5 | ns | |
| EXTAL clock input frequency | f_{EX} | 4 | 12.5 | MHz | Figure 26.3 |
| EXTAL clock input cycle time | t_{EXcyc} | 80 | 250 | ns | |
| EXTAL clock input low-level pulse width | t_{EXL} | 35 | — | ns | |
| EXTAL clock input high-level pulse width | t_{EXH} | 35 | — | ns | |
| EXTAL clock input rise time | t_{EXR} | — | 5 | ns | |
| EXTAL clock input fall time | t_{EXF} | — | 5 | ns | |
| Reset oscillation settling time | t_{OSC1} | 10 | — | ms | Figure 26.4 |
| Standby return oscillation settling time | t_{OSC2} | 10 | — | ms | |
| Clock cycle time for peripheral modules | t_{pccyc} | 25 | 500 | ns | |

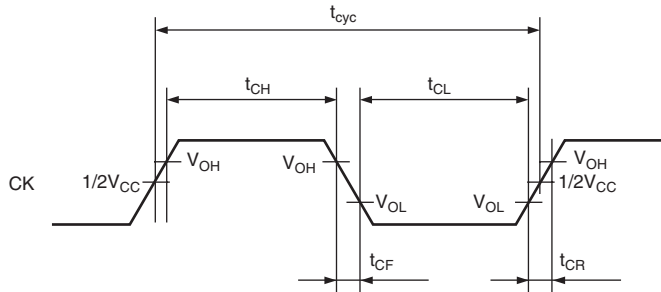

Figure 26.2 System Clock Timing

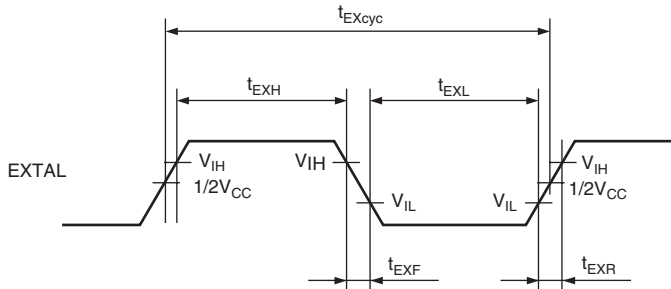

Figure 26.3 EXTAL Clock Input Timing

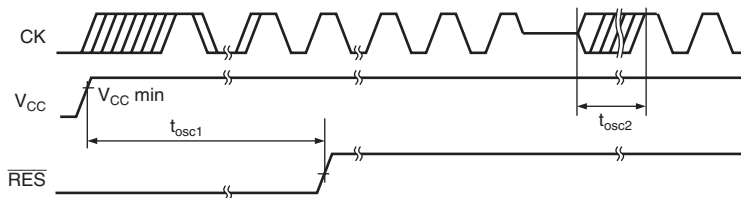

Figure 26.4 Oscillation Settling Time

26.3.3 Control Signal Timing

Table 26.5 shows control signal timing.

Table 26.5 Control Signal Timing

Conditions: $V_{CC} = PLLV_{CC} = 3.3 \text{ V} \pm 0.3 \text{ V}$, $AV_{CC} = 3.3 \text{ V} \pm 0.3 \text{ V}$, $AV_{CC} = V_{CC} \pm 0.3 \text{ V}$,
 $AV_{ref} = 3.0 \text{ V}$ to AV_{CC} , $V_{SS} = PLLV_{SS} = AV_{SS} = 0 \text{ V}$, $T_a = -20^\circ\text{C}$ to $+75^\circ\text{C}$
 (regular specifications), $T_a = -40^\circ\text{C}$ to $+85^\circ\text{C}$ (wide-range specifications),
 When programming or erasing flash memory, $T_a = -20^\circ\text{C}$ to $+75^\circ\text{C}$.

| Item | Symbol | Min. | Max. | Unit | Figure |
|--|------------------------------------|------|------|------------------|-------------|
| $\overline{\text{RES}}$ rise time, fall time | $t_{\text{RESr}}, t_{\text{RESf}}$ | — | 200 | ns | Figure 26.5 |
| $\overline{\text{RES}}$ pulse width | t_{RESW} | 25 | — | t_{cyc} | |
| $\overline{\text{RES}}$ setup time | t_{RESS} | 35 | — | ns | |
| $\overline{\text{MRES}}$ pulse width | t_{MRESW} | 20 | — | t_{cyc} | |
| $\overline{\text{MRES}}$ setup time | t_{MRESS} | 35 | — | ns | |
| MD3 to MD0 setup time | t_{MDS} | 20 | — | t_{cyc} | |
| NMI rise time, fall time | $t_{\text{NMIr}}, t_{\text{NMIf}}$ | — | 200 | ns | Figure 26.6 |
| NMI setup time | t_{NMIS} | 35 | — | ns | |
| NMI hold time | t_{NMIH} | 35 | — | ns | |
| $\overline{\text{IRQ7}}$ to $\overline{\text{IRQ0}}$ setup time* (edge detection) | t_{IRQES} | 19 | — | ns | |
| $\overline{\text{IRQ7}}$ to $\overline{\text{IRQ0}}$ setup time* (level detection) | t_{IRQLS} | 19 | — | ns | |
| $\overline{\text{IRQ7}}$ to $\overline{\text{IRQ0}}$ hold time | t_{IRQEH} | 19 | — | ns | |
| $\overline{\text{IRQOUT}}$ output delay time | t_{IRQOD} | — | 100 | ns | Figure 26.7 |
| Bus request setup time | t_{BRQS} | 19 | — | ns | Figure 26.8 |
| Bus acknowledge delay time 1 | t_{BACKD1} | — | 35 | ns | |
| Bus acknowledge delay time 2 | t_{BACKD2} | — | 35 | ns | |
| Bus three-state delay time | t_{BZD} | — | 35 | ns | |

[Operating Precautions]

- * The $\overline{\text{RES}}$, $\overline{\text{MRES}}$, NMI and $\overline{\text{IRQ7}}$ to $\overline{\text{IRQ0}}$ signals are asynchronous inputs, but when the setup times shown here are observed, the signals are considered to have been changed at clock rise ($\overline{\text{RES}}$, $\overline{\text{MRES}}$) or fall (NMI and $\overline{\text{IRQ7}}$ to $\overline{\text{IRQ0}}$). If the setup times are not observed, the recognition of these signals may be delayed until the next clock rise or fall.

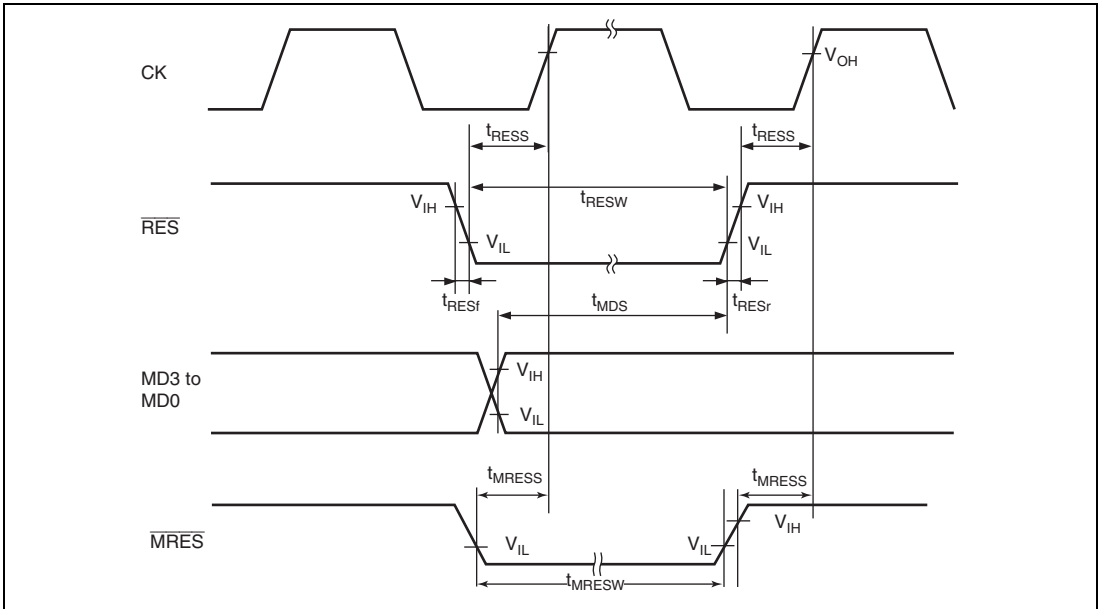

Figure 26.5 Reset Input Timing

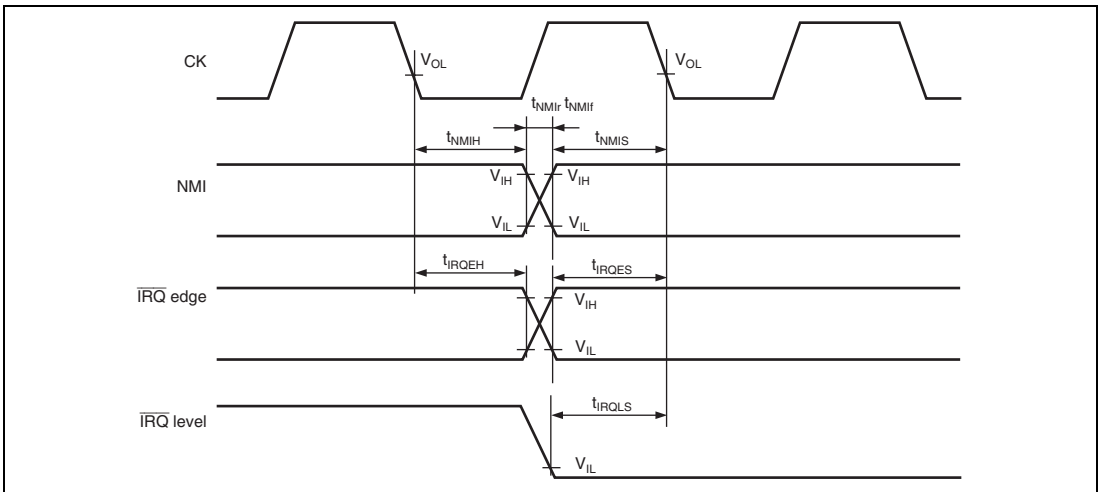

Figure 26.6 Interrupt Signal Input Timing

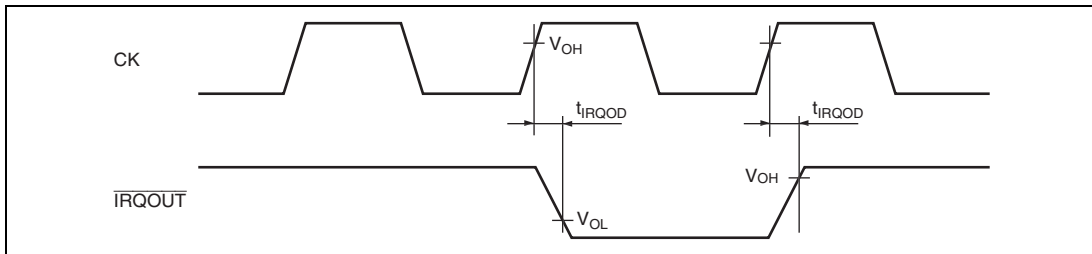

Figure 26.7 Interrupt Signal Output Timing

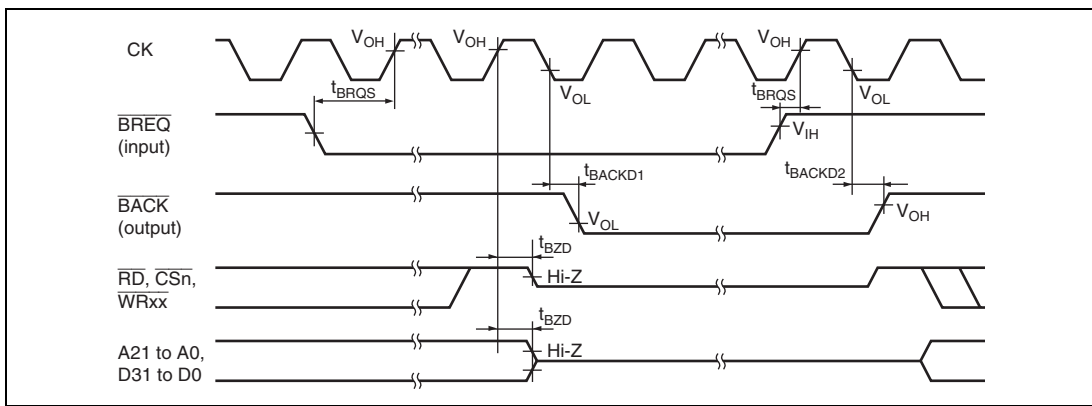

Figure 26.8 Bus Release Timing

26.3.4 Bus Timing

Table 26.6 shows bus timing.

Table 26.6 Bus Timing

Conditions: $V_{CC} = PLLV_{CC} = 3.3\text{ V} \pm 0.3\text{ V}$, $AV_{CC} = 3.3\text{ V} \pm 0.3\text{ V}$, $AV_{CC} = V_{CC} \pm 0.3\text{ V}$,
 $AV_{ref} = 3.0\text{ V}$ to AV_{CC} , $V_{SS} = PLLV_{SS} = AV_{SS} = 0\text{ V}$, $T_a = -20^\circ\text{C}$ to $+75^\circ\text{C}$
 (regular specifications), $T_a = -40^\circ\text{C}$ to $+85^\circ\text{C}$ (wide-range specifications),
 When programming or erasing flash memory, $T_a = -20^\circ\text{C}$ to $+75^\circ\text{C}$.

| Item | Symbol | Min. | Max. | Unit | Figure |
|------------------------------|----------------|--------------------------------------|------|------|------------------------|
| Address delay time | t_{AD} | — | 25 | ns | Figures 26.9, 26.10 |
| \overline{CS} delay time 1 | t_{CSD1} | — | 28 | ns | |
| \overline{CS} delay time 2 | t_{CSD2} | — | 28 | ns | |
| Read strobe delay time 1 | t_{RSD1} | — | 25 | ns | |
| Read strobe delay time 2 | t_{RSD2} | — | 25 | ns | |
| Read data setup time | t_{RDS} | 15 | — | ns | |
| Read data hold time | t_{RDH} | 0 | — | ns | |
| Write strobe delay time 1 | t_{WSD1} | — | 25 | ns | |
| Write strobe delay time 2 | t_{WSD2} | — | 25 | ns | |
| Write data delay time | t_{WDD} | — | 30 | ns | |
| Write data hold time | t_{WDH} | 0 | — | ns | |
| \overline{WAIT} setup time | t_{WTS} | 12 | — | ns | Figure 26.11 |
| \overline{WAIT} hold time | t_{WTH} | 3 | — | ns | |
| Read data access time | t_{ACC}^{*5} | $t_{cyc} \times (n + 2) - 35^{*1*2}$ | — | ns | Figures 26.9, 26.10 |
| Access time from read strobe | t_{OE}^{*5} | $t_{cyc} \times (n + 1.5) - 33^{*1}$ | — | ns | |
| Address setup time (Read) | t_{ASR} | 0^{*3} | — | ns | |
| Address setup time (Write) | t_{ASW} | 0^{*3} | — | ns | |
| Address hold time (Write) | t_{WR} | 5^{*4} | — | ns | |
| Write data hold time | t_{WRH} | 0^{*3} | — | ns | |
| DACK delay time | t_{DACKD} | — | 28 | ns | |

- Notes: 1. The letter n means the number of waits.
 2. When \overline{CS} assert time is extended, this value is equal to $t_{cyc} \times (n + 3) - 35$.
 3. When \overline{CS} assert time is extended, this value is equal to t_{cyc} .
 4. When \overline{CS} assert time is extended, this value is equal to $5 + t_{cyc}$.
 5. If access time is satisfied, there is no need that t_{RDS} is satisfied.

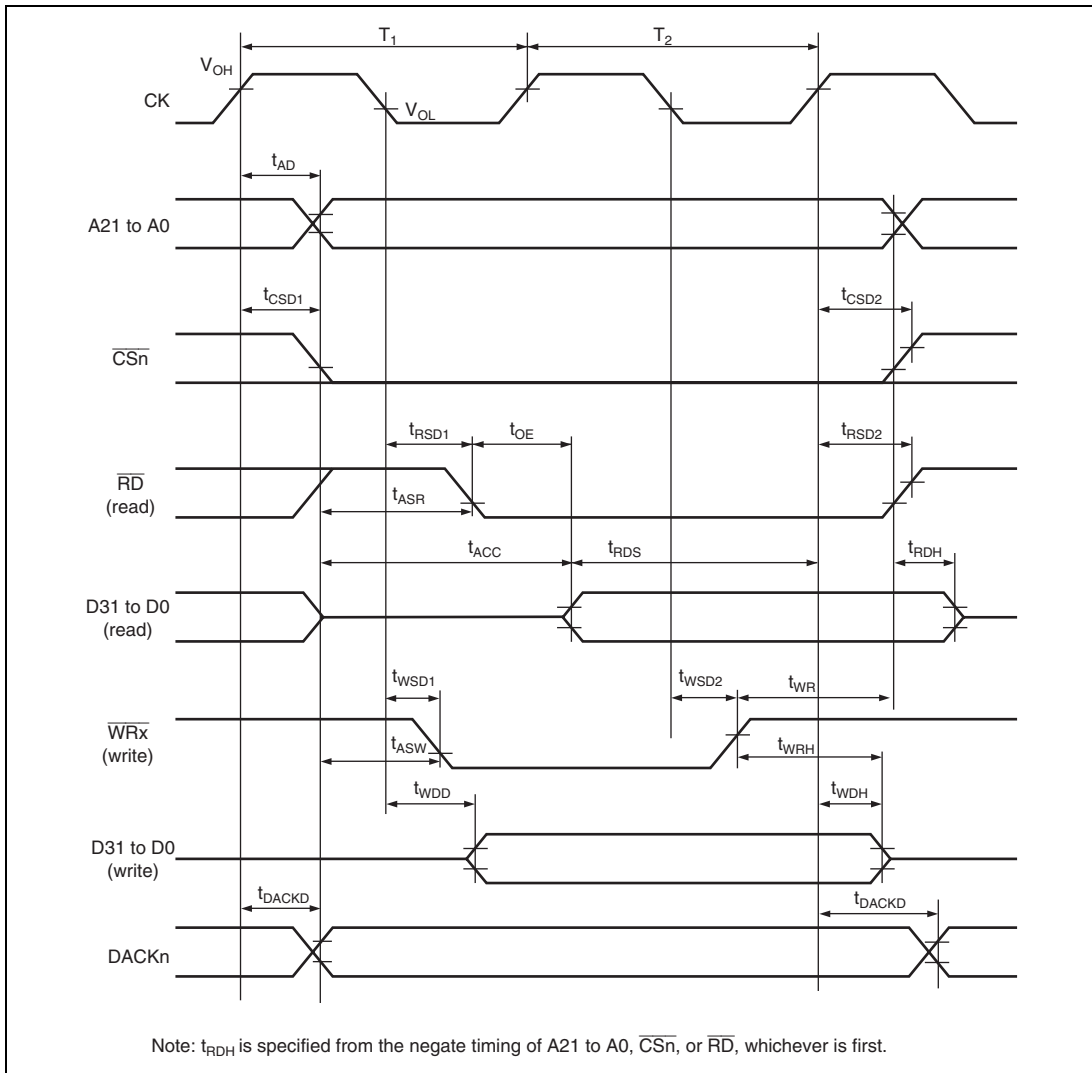
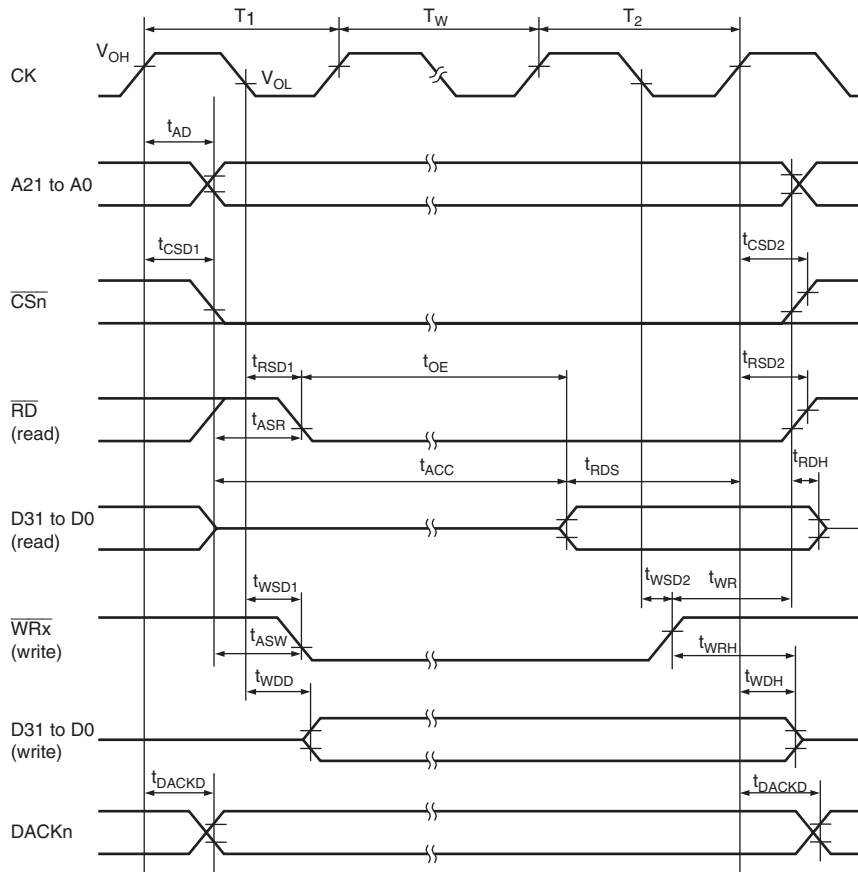
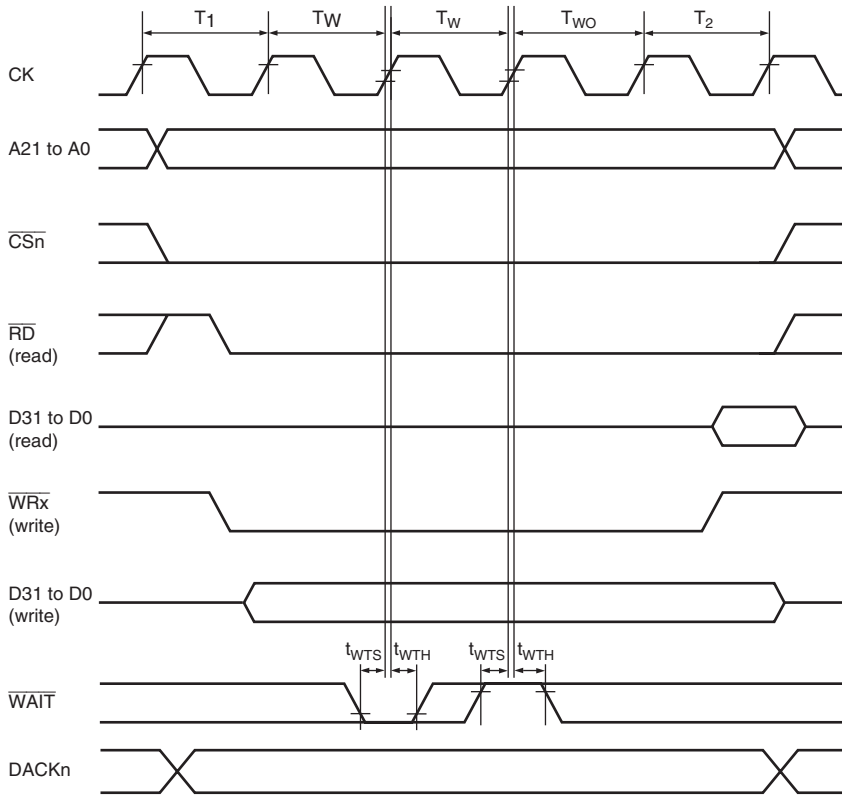

Figure 26.9 Basic Cycle (No Waits)



Note: t_{RDH} is specified from the negate timing of A_{21} to A_0 , \overline{CS}_n , or \overline{RD} , whichever is first.

Figure 26.10 Basic Cycle (One Software Wait)



Note: t_{RDH} is specified from the negate timing of A21 to A0, \overline{CSn} , or \overline{RD} , whichever is first.

Figure 26.11 Basic Cycle (Two Software Waits + Waits by WAIT Signal)

26.3.5 Direct Memory Access Controller (DMAC) Timing

Table 26.7 shows direct memory access controller timing.

Table 26.7 Direct Memory Access Controller Timing

Conditions: $V_{CC} = PLLV_{CC} = 3.3 \text{ V} \pm 0.3 \text{ V}$, $AV_{CC} = 3.3 \text{ V} \pm 0.3 \text{ V}$, $AV_{CC} = V_{CC} \pm 0.3 \text{ V}$,
 $AV_{ref} = 3.0 \text{ V to } AV_{CC}$, $V_{SS} = PLLV_{SS} = AV_{SS} = 0 \text{ V}$, $T_a = -20^\circ\text{C to } +75^\circ\text{C}$
 (regular specifications), $T_a = -40^\circ\text{C to } +85^\circ\text{C}$ (wide-range specifications),
 When programming or erasing flash memory, $T_a = -20^\circ\text{C to } +75^\circ\text{C}$.

| Item | Symbol | Min. | Max. | Unit | Figure |
|---|--------------------|---------------------------|------|------------------|--------------|
| $\overline{\text{DREQ0}}$, $\overline{\text{DREQ1}}$ setup time | t_{DROS} | 10 | — | ns | Figure 26.12 |
| $\overline{\text{DREQ0}}$, $\overline{\text{DREQ1}}$ hold time | t_{DRQH} | $1.5 t_{\text{cyc}} - 10$ | — | ns | |
| $\overline{\text{DREQ0}}$, $\overline{\text{DREQ1}}$ pulse width | t_{DROW} | 1.5 | — | t_{cyc} | Figure 26.13 |
| DRAK0 , DRAK1 output delay time | t_{DRAKD} | — | 30 | ns | Figure 26.14 |

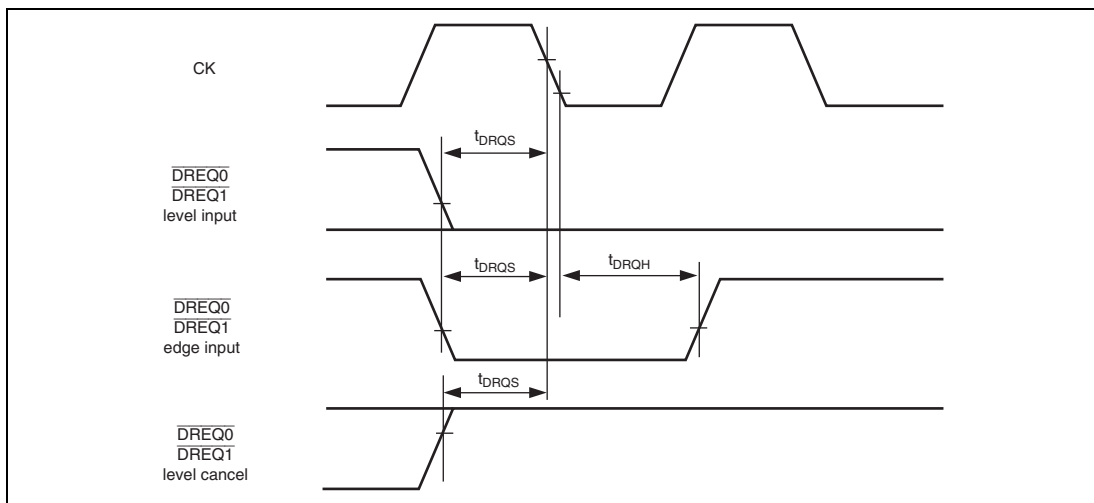

Figure 26.12 $\overline{\text{DREQ0}}$, $\overline{\text{DREQ1}}$ Input Timing (1)

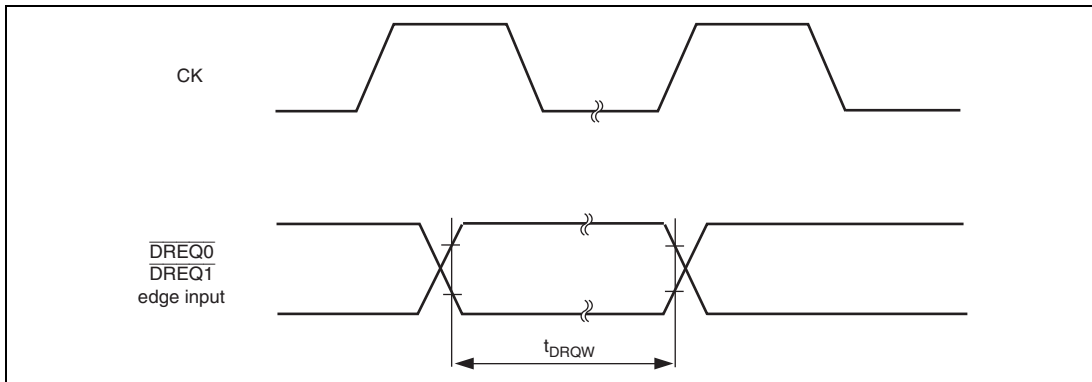

Figure 26.13 $\overline{\text{DREQ0}}$, $\overline{\text{DREQ1}}$ Input Timing (2)

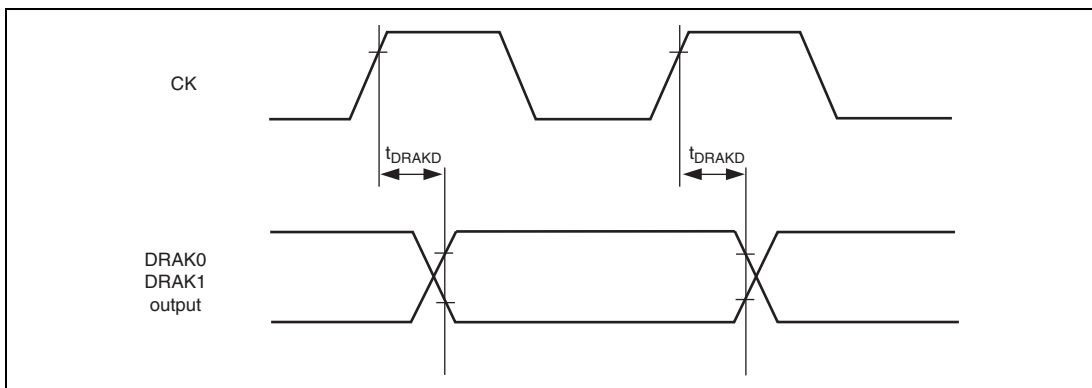

Figure 26.14 DRAK Output Delay Time

26.3.6 Multi-Function Timer Pulse Unit (MTU) Timing

Table 26.8 shows Multi-Function timer pulse unit timing.

Table 26.8 Multi-Function Timer Pulse Unit Timing

Conditions: $V_{CC} = PLLV_{CC} = 3.3\text{ V} \pm 0.3\text{ V}$, $AV_{CC} = 3.3\text{ V} \pm 0.3\text{ V}$, $AV_{CC} = V_{CC} \pm 0.3\text{ V}$,
 $AV_{ref} = 3.0\text{ V}$ to AV_{CC} , $V_{SS} = PLLV_{SS} = AV_{SS} = 0\text{ V}$, $T_a = -20^\circ\text{C}$ to $+75^\circ\text{C}$
 (regular specifications), $T_a = -40^\circ\text{C}$ to $+85^\circ\text{C}$ (wide-range specifications),
 When programming or erasing flash memory, $T_a = -20^\circ\text{C}$ to $+75^\circ\text{C}$.

| Item | Symbol | Min. | Max. | Unit | Figure |
|---|---------------|------|------|-------------------|--------------|
| Output compare output delay time | t_{TOCD} | — | 100 | ns | Figure 26.15 |
| Input capture input setup time | t_{TICS} | 19 | — | ns | |
| Timer input setup time | t_{TCKS} | 19 | — | ns | |
| Timer clock pulse width (single edge specified) | $t_{TCKWH/L}$ | 1.5 | — | $t_{p\text{cyc}}$ | Figure 26.16 |
| Timer clock pulse width (both edges specified) | $t_{TCKWH/L}$ | 2.5 | — | $t_{p\text{cyc}}$ | |
| Timer clock pulse width (phase count mode) | $t_{TCKWH/L}$ | 2.5 | — | $t_{p\text{cyc}}$ | |

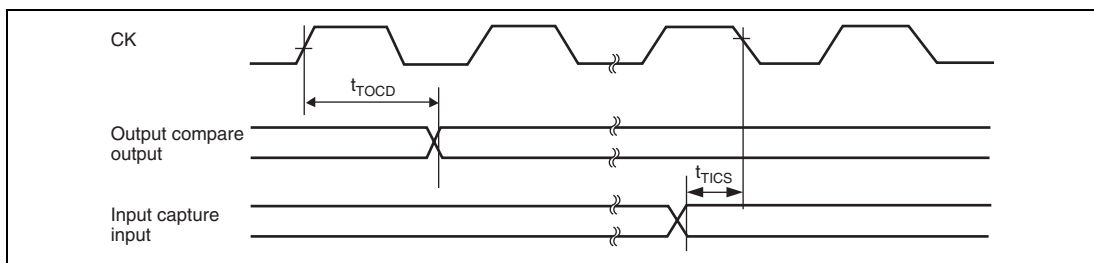

Figure 26.15 MTU Input/Output timing

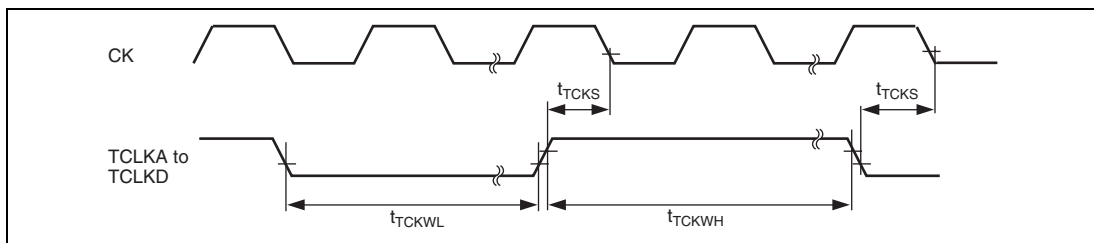

Figure 26.16 MTU Clock Input Timing

26.3.7 I/O Port Timing

Table 26.9 shows I/O port timing.

Table 26.9 I/O Port Timing

Conditions: $V_{CC} = PLLV_{CC} = 3.3\text{ V} \pm 0.3\text{ V}$, $AV_{CC} = 3.3\text{ V} \pm 0.3\text{ V}$, $AV_{CC} = V_{CC} \pm 0.3\text{ V}$,
 $AV_{ref} = 3.0\text{ V}$ to AV_{CC} , $V_{SS} = PLLV_{SS} = AV_{SS} = 0\text{ V}$, $T_a = -20^\circ\text{C}$ to $+75^\circ\text{C}$
 (regular specifications), $T_a = -40^\circ\text{C}$ to $+85^\circ\text{C}$ (wide-range specifications),
 When programming or erasing flash memory, $T_a = -20^\circ\text{C}$ to $+75^\circ\text{C}$.

| Item | Symbol | Min. | Max. | Unit | Figure |
|-----------------------------|-----------|------|------|------|--------------|
| Port output data delay time | t_{PWD} | — | 100 | ns | Figure 26.17 |
| Port input hold time | t_{PRH} | 19 | — | ns | |
| Port input setup time | t_{PRS} | 19 | — | ns | |

[Operating precautions]

The port input signals are asynchronous. They are, however, considered to have been changed at CK clock fall with two-state intervals shown in figure 26.17. If the setup times shown here are not observed, recognition may be delayed until the clock fall two states after that timing.

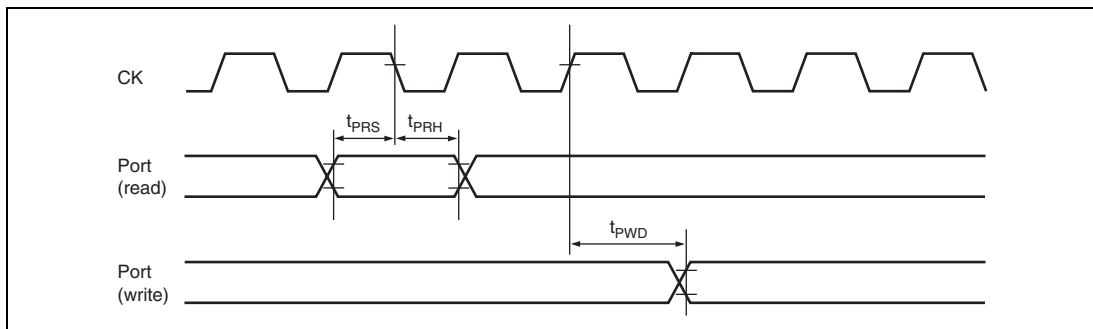

Figure 26.17 I/O Port Input/Output timing

26.3.8 Watchdog Timer (WDT)Timing

Table 26.10 shows watchdog timer timing.

Table 26.10 Watchdog Timer Timing

Conditions: $V_{CC} = PLLV_{CC} = 3.3\text{ V} \pm 0.3\text{ V}$, $AV_{CC} = 3.3\text{ V} \pm 0.3\text{ V}$, $AV_{CC} = V_{CC} \pm 0.3\text{ V}$,
 $AV_{ref} = 3.0\text{ V}$ to AV_{CC} , $V_{SS} = PLLV_{SS} = AV_{SS} = 0\text{ V}$, $T_a = -20^\circ\text{C}$ to $+75^\circ\text{C}$
 (regular specifications), $T_a = -40^\circ\text{C}$ to $+85^\circ\text{C}$ (wide-range specifications),
 When programming or erasing flash memory, $T_a = -20^\circ\text{C}$ to $+75^\circ\text{C}$.

| Item | Symbol | Min. | Max. | Unit | Figure |
|-------------------|-------------|------|------|------|--------------|
| WDTOVF delay time | t_{WDOVF} | — | 100 | ns | Figure 26.18 |

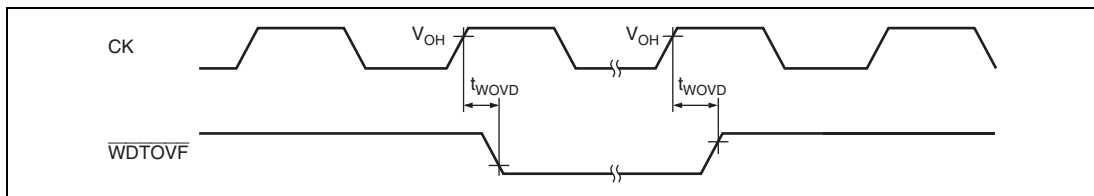

Figure 26.18 WDT Timing

26.3.9 Serial Communication Interface (SCI) Timing

Table 26.11 shows serial communication interface timing.

Table 26.11 Serial Communication Interface Timing

Conditions: $V_{CC} = PLLV_{CC} = 3.3 \text{ V} \pm 0.3 \text{ V}$, $AV_{CC} = 3.3 \text{ V} \pm 0.3 \text{ V}$, $AV_{CC} = V_{CC} \pm 0.3 \text{ V}$,
 $AV_{ref} = 3.0 \text{ V}$ to AV_{CC} , $V_{SS} = PLLV_{SS} = AV_{SS} = 0 \text{ V}$, $T_a = -20^\circ\text{C}$ to $+75^\circ\text{C}$
 (regular specifications), $T_a = -40^\circ\text{C}$ to $+85^\circ\text{C}$ (wide-range specifications),
 When programming or erasing flash memory, $T_a = -20^\circ\text{C}$ to $+75^\circ\text{C}$.

| Item | | Symbol | Min. | Max. | Unit | Figure |
|----------------------------------|-------------------|------------|---------------------|-----------------|------------|--------------|
| Input clock cycle (asynchronous) | | t_{scyc} | 4 | — | t_{pcyc} | Figure 26.19 |
| Input clock cycle (clock sync) | | t_{scyc} | 6 | — | t_{pcyc} | |
| Input clock pulse width | | t_{sckw} | 0.4 | 0.6 | t_{scyc} | |
| Input clock rise time | | t_{sckr} | — | 1.5 | t_{pcyc} | |
| Input clock fall time | | t_{sckf} | — | 1.5 | t_{pcyc} | |
| Transmit data delay time | asynchronous | t_{TxD} | — | 100 | ns | Figure 26.20 |
| Received data setup time | | t_{RxS} | 100 | — | ns | |
| Received data hold time | | t_{RxH} | 100 | — | ns | |
| Transmit data delay time | clock sync | t_{TxD} | — | $t_{pcyc} + 43$ | ns | |
| Received data setup time | (When SCK input) | t_{RxS} | $t_{pcyc} + 25$ | — | ns | |
| Received data hold time | | t_{RxH} | $t_{pcyc} + 25$ | — | ns | |
| Transmit data delay time | clock sync | t_{TxD} | — | 65 | ns | |
| Received data setup time | (When SCK output) | t_{RxS} | $0.5 t_{pcyc} + 50$ | — | ns | |
| Received data hold time | | t_{RxH} | $1.5 t_{pcyc}$ | — | ns | |

[Operating Precautions]

The inputs and outputs are asynchronous in asynchronous mode, but as shown in figure 26.20, the received data is considered to have been changed at CK clock rise (two-clock intervals). The transmit signals change with a reference of CK clock rise (two-clock intervals).

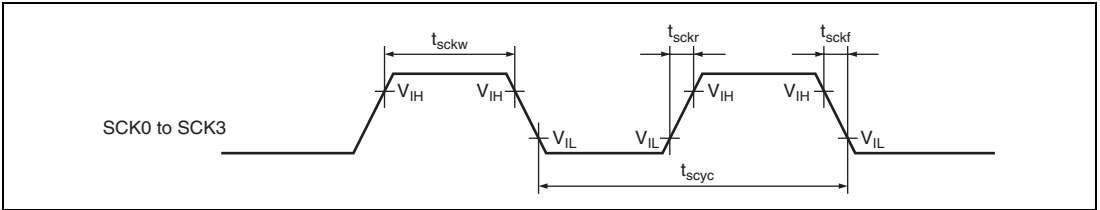

Figure 26.19 SCI Input Timing

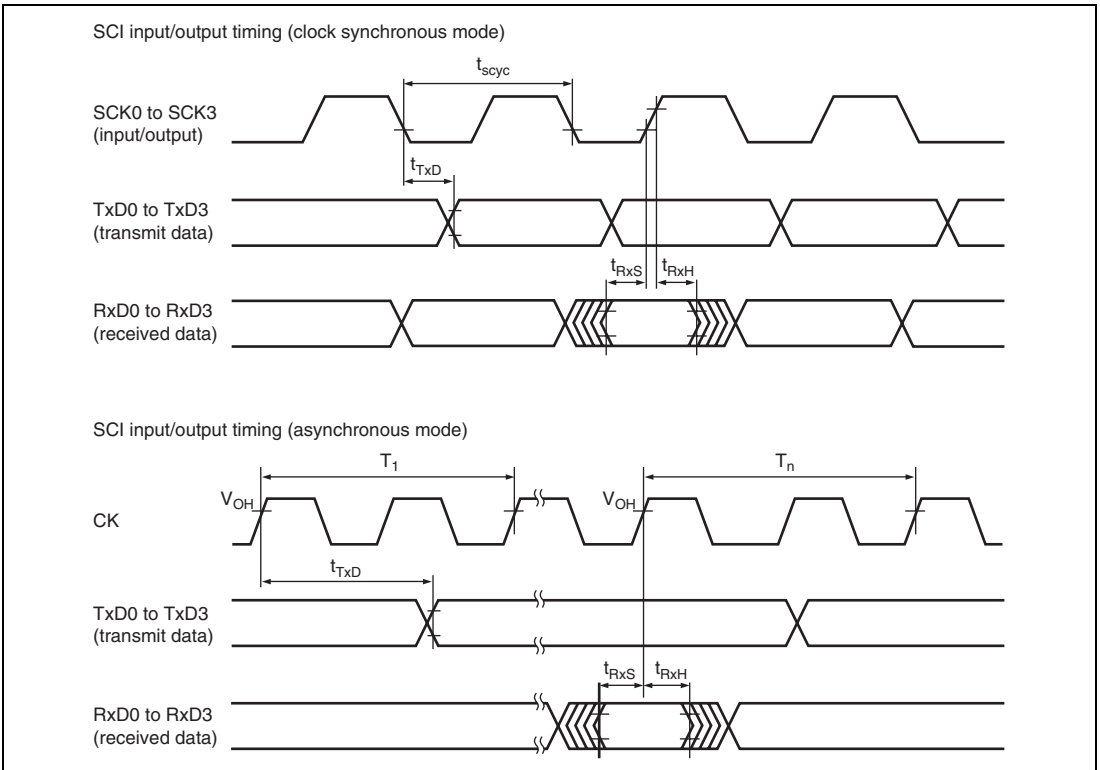

Figure 26.20 SCI Input/Output Timing

26.3.10 I²C Bus Interface Timing

Table 26.12 shows I²C bus interface timing.

Table 26.12 I²C Bus Interface Timing

Conditions: $V_{CC} = PLLV_{CC} = 3.3 \text{ V} \pm 0.3 \text{ V}$, $AV_{CC} = 3.3 \text{ V} \pm 0.3 \text{ V}$, $AV_{CC} = V_{CC} \pm 0.3 \text{ V}$,
 $AV_{ref} = 3.0 \text{ V}$ to AV_{CC} , $V_{SS} = PLLV_{SS} = AV_{SS} = 0 \text{ V}$, $T_a = -20^\circ\text{C}$ to $+75^\circ\text{C}$
 (regular specifications), $T_a = -40^\circ\text{C}$ to $+85^\circ\text{C}$ (wide-range specifications),
 When programming or erasing flash memory, $T_a = -20^\circ\text{C}$ to $+75^\circ\text{C}$.

| Item | Symbol | Min. | Typ. | Max. | Unit | Figure |
|---|------------|-------------------------------------|------|--------------------------------------|------|--------------|
| SCL input cycle time | t_{SCL} | 12 $t_{p\text{cyc}}$ * ¹ | — | — | ns | Figure 26.21 |
| SCL input high pulse width | t_{SCLH} | 3 $t_{p\text{cyc}}$ | — | — | ns | |
| SCL input low pulse width | t_{SCLL} | 5 $t_{p\text{cyc}}$ | — | — | ns | |
| SCL and SDA input rise time | t_{Sr} | — | — | 7.5 $t_{p\text{cyc}}$ * ² | ns | |
| SCL and SDA input fall time | t_{Sf} | — | — | 300 | ns | |
| SCL and SDA input spike pulse removal time | t_{SP} | — | — | 1 $t_{p\text{cyc}}$ | ns | |
| SDA input bus free time | t_{BUF} | 5 $t_{p\text{cyc}}$ | — | — | ns | |
| Start condition input hold time | t_{STAH} | 3 $t_{p\text{cyc}}$ | — | — | ns | |
| Retransmission start condition input setup time | t_{STAS} | 3 $t_{p\text{cyc}}$ | — | — | ns | |
| Halt condition input setup time | t_{STOS} | 3 $t_{p\text{cyc}}$ | — | — | ns | |
| Data input setup time | t_{SDAS} | 35 | — | — | ns | |
| Data input hold time | t_{SDAH} | 0 | — | — | ns | |
| SCL and SDA capacity load | C_b | — | — | 400 | pF | |

- Notes: 1. $t_{p\text{cyc}}$ (ns) = 1/(P ϕ supplied to I²C module (MHz))
 2. Can be set to 17.5 $t_{p\text{cyc}}$ by selecting the clock to be used for the I²C module. For details, refer to section 14.5, Usage Notes.

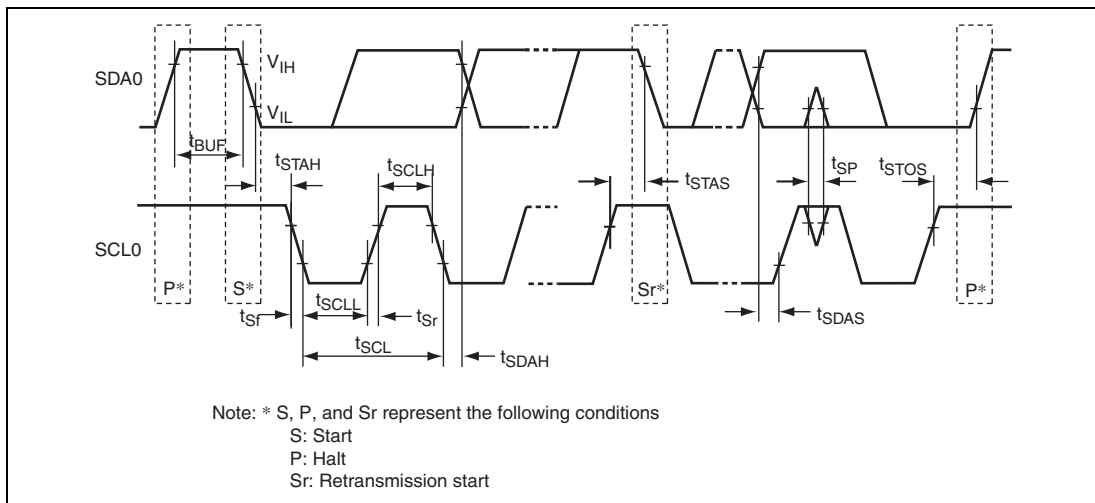

Figure 26.21 I²C Bus Interface Timing

26.3.11 Port Output Enable (POE) Timing

Table 26.13 shows port output enable (POE) timing.

Table 26.13 Port Output Enable Timing

Conditions: $V_{CC} = PLLV_{CC} = 3.3 \text{ V} \pm 0.3 \text{ V}$, $AV_{CC} = 3.3 \text{ V} \pm 0.3 \text{ V}$, $AV_{CC} = V_{CC} \pm 0.3 \text{ V}$, $AV_{ref} = 3.0 \text{ V}$ to AV_{CC} , $V_{SS} = PLLV_{SS} = AV_{SS} = 0 \text{ V}$, $T_a = -20^\circ\text{C}$ to $+75^\circ\text{C}$ (regular specifications), $T_a = -40^\circ\text{C}$ to $+85^\circ\text{C}$ (wide-range specifications), When programming or erasing flash memory, $T_a = -20^\circ\text{C}$ to $+75^\circ\text{C}$.

| Item | Symbol | Min. | Max. | Unit | Figure |
|-----------------------|------------|------|------|-------|--------------|
| POE input setup time | t_{POES} | 100 | — | ns | Figure 26.22 |
| POE input pulse width | t_{POEW} | 1.5 | — | tpcyc | |

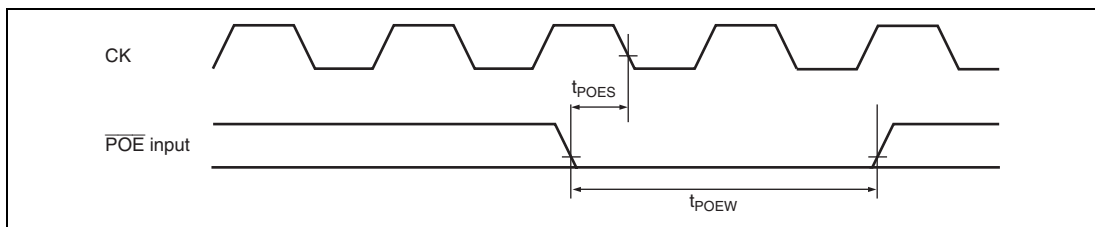

Figure 26.22 POE Input/Output Timing

26.3.12 A/D Converter Timing

Table 26.14 shows A/D converter timing.

Table 26.14 A/D Converter Timing

Conditions: $V_{CC} = PLLV_{CC} = 3.3 \text{ V} \pm 0.3 \text{ V}$, $AV_{CC} = 3.3 \text{ V} \pm 0.3 \text{ V}$, $AV_{CC} = V_{CC} \pm 0.3 \text{ V}$,
 $AV_{ref} = 3.0 \text{ V}$ to AV_{CC} , $V_{SS} = PLLV_{SS} = AV_{SS} = 0 \text{ V}$, $T_a = -20^\circ\text{C}$ to $+75^\circ\text{C}$
 (regular specifications), $T_a = -40^\circ\text{C}$ to $+85^\circ\text{C}$ (wide-range specifications),
 When programming or erasing flash memory, $T_a = -20^\circ\text{C}$ to $+75^\circ\text{C}$.

| Item | Symbol | Min. | Typ. | Max. | Unit | Figure |
|---|------------|------|------|------|------|--------------|
| External trigger input start delay time | t_{TRGS} | 50 | — | — | ns | Figure 26.23 |

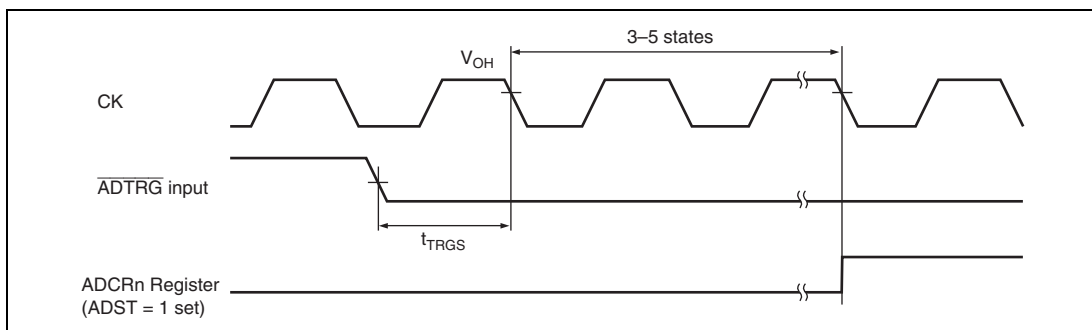

Figure 26.23 External Trigger Input Timing

26.3.13 H-UDI Timing

Table 26.15 shows H-UDI timing.

Table 26.15 H-UDI Timing

Conditions: $V_{CC} = PLLV_{CC} = 3.3\text{ V} \pm 0.3\text{ V}$, $AV_{CC} = 3.3\text{ V} \pm 0.3\text{ V}$, $AV_{CC} = V_{CC} \pm 0.3\text{ V}$,
 $AV_{ref} = 3.0\text{ V}$ to AV_{CC} , $V_{SS} = PLLV_{SS} = AV_{SS} = 0\text{ V}$, $T_a = -20^\circ\text{C}$ to $+75^\circ\text{C}$
 (regular specifications), $T_a = -40^\circ\text{C}$ to $+85^\circ\text{C}$ (wide-range specifications),
 When programming or erasing flash memory, $T_a = -20^\circ\text{C}$ to $+75^\circ\text{C}$.

| Item | Symbol | Min. | Max. | Unit | Figure |
|--------------------------------------|-------------------|------|------|------------------|--------------|
| TCK clock cycle | t_{cyc} | 60* | 500 | ns | Figure 26.24 |
| TCK clock high-level width | t_{TCKH} | 0.4 | 0.6 | t_{cyc} | |
| TCK clock low-level width | t_{TCKL} | 0.4 | 0.6 | t_{cyc} | |
| $\overline{\text{TRST}}$ pulse width | t_{TRSW} | 20 | — | t_{cyc} | Figure 26.25 |
| $\overline{\text{TRST}}$ setup time | t_{TRSS} | 30 | — | ns | |
| TMS setup time | t_{TMSS} | 15 | — | ns | Figure 26.26 |
| TMS hold time | t_{TMSH} | 10 | — | ns | |
| TDI setup time | t_{TDIS} | 15 | — | ns | |
| TDI hold time | t_{TDIH} | 10 | — | ns | |
| TDO delay time | t_{TDOD} | — | 30 | ns | |

Note: * The value must not be under $2 \times t_{\text{cyc}}$.

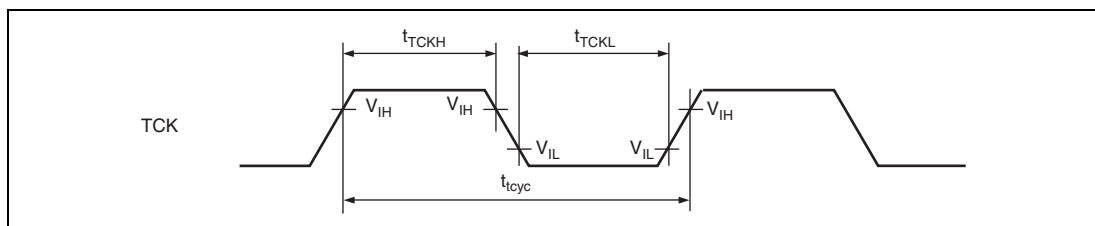

Figure 26.24 H-UDI Clock Timing

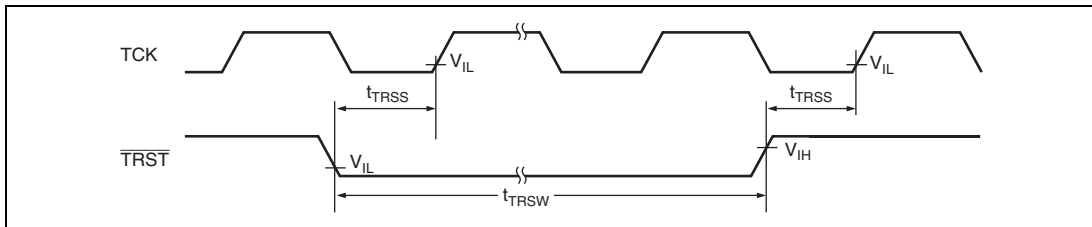

Figure 26.25 H-UDI TRST Timing

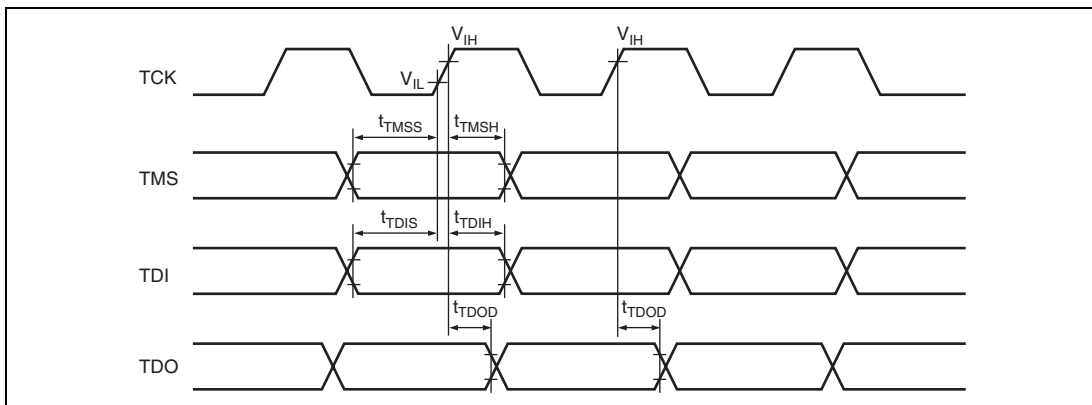

Figure 26.26 H-UDI Input/Output Timing

26.3.14 AUD Timing

Table 26.16 shows AUD timing.

Table 26.16 AUD Timing

Conditions: $V_{CC} = PLLV_{CC} = 3.3\text{ V} \pm 0.3\text{ V}$, $AV_{CC} = 3.3\text{ V} \pm 0.3\text{ V}$, $AV_{CC} = V_{CC} \pm 0.3\text{ V}$,
 $AV_{ref} = 3.0\text{ V}$ to AV_{CC} , $V_{SS} = PLLV_{SS} = AV_{SS} = 0\text{ V}$, $T_a = -20^\circ\text{C}$ to $+75^\circ\text{C}$
 (regular specifications), $T_a = -40^\circ\text{C}$ to $+85^\circ\text{C}$ (wide-range specifications),
 When programming or erasing flash memory, $T_a = -20^\circ\text{C}$ to $+75^\circ\text{C}$.

| Item | Symbol | Min. | Max. | Unit | Figure |
|------------------------------------|--------------------------|-------------|------------------|-------------|--------------|
| AUDRST pulse width (Branch trace) | $t_{AUDRSTW}$ | 20 | — | t_{cyc} | Figure 26.27 |
| AUDRST pulse width (RAM monitor) | $t_{AUDRSTW}$ | 5 | — | t_{RMCYC} | |
| AUDMD setup time (Branch trace) | t_{AUDMDS} | 20 | — | t_{cyc} | |
| AUDMD setup time (RAM monitor) | t_{AUDMDS} | 5 | — | t_{RMCYC} | |
| Branch trace clock cycle | t_{BTCYC} | 2 | 2 | t_{cyc} | Figure 26.28 |
| Branch trace clock duty | t_{BTCKW} | 40 | 60 | % | |
| Branch trace data delay time | t_{BTDD} | — | 11 | ns | |
| Branch trace data hold time | t_{BTDH} | -10 | — | ns | |
| Branch trace SYNC delay time | t_{BTSD} | — | 10 | ns | |
| Branch trace SYNC hold time | t_{BTSH} | -10 | — | ns | |
| RAM monitor clock cycle | t_{RMCYC} | 80 | — | ns | Figure 26.29 |
| RAM monitor clock low pulse width | t_{RMCKW} | 35 | — | ns | |
| RAM monitor output data delay time | t_{RMDD} | 7 | $t_{RMCYC} - 20$ | ns | |
| RAM monitor output data hold time | t_{RMDHD} | 5 | — | ns | |
| RAM monitor input data setup time | t_{RMDS} | 10 | — | ns | |
| RAM monitor input data hold time | PE3/AUDATA3, PE4/AUDATA2 | t_{RMDH} | $15 + t_{RMCYC}$ | — | ns |
| | Other AUDATA pins | | t_{RMCKW} | — | ns |
| RAM monitor SYNC setup time | t_{RMSS} | 10 | — | ns | |
| RAM monitor SYNC hold time | PA16/AUDSYNC | t_{RMSH} | $13 + t_{RMCYC}$ | — | ns |
| | Other AUDSYNC pins | | t_{RMCKW} | — | ns |
| Load conditions: | AUDCK (output): | CL = 30 pF | | | |
| | AUDSYNC: | CL = 100 pF | | | |
| | AUDATA3 to AUDATA0: | CL = 100 pF | | | |

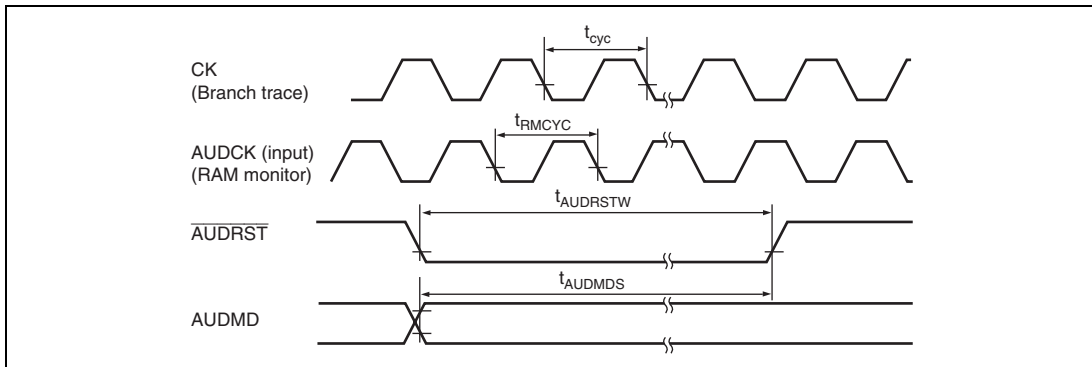

Figure 26.27 AUD Reset Timing

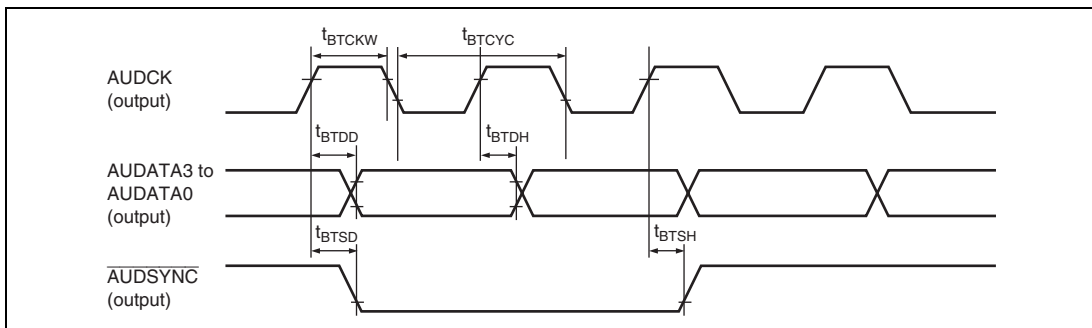

Figure 26.28 Branch Trace Timing

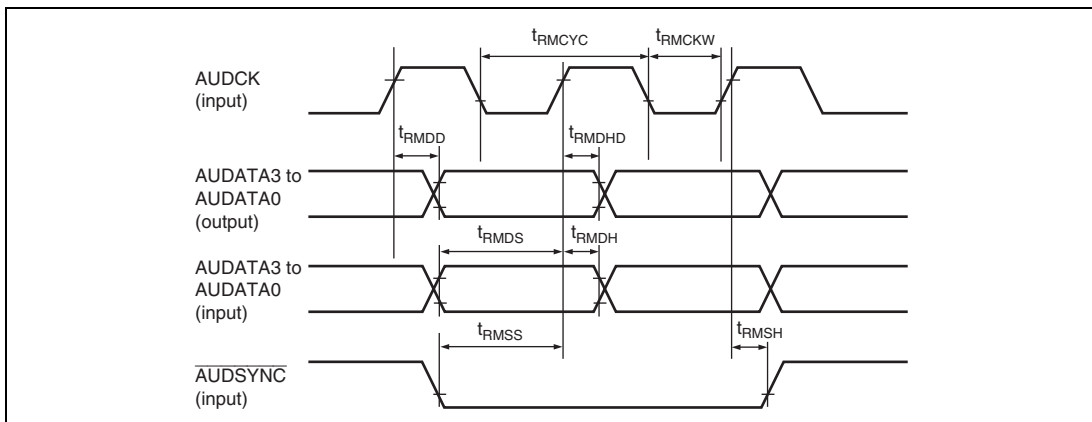

Figure 26.29 RAM Monitor Timing

26.4 A/D Converter Characteristics

Table 26.17 shows A/D converter characteristics.

Table 26.17 A/D Converter Characteristics

Conditions: $V_{CC} = PLLV_{CC} = 3.3 \text{ V} \pm 0.3 \text{ V}$, $AV_{CC} = 3.3 \text{ V} \pm 0.3 \text{ V}$, $AV_{CC} = V_{CC} \pm 0.3 \text{ V}$,
 $AV_{ref} = 3.0 \text{ V}$ to AV_{CC} , $V_{SS} = PLLV_{SS} = AV_{SS} = 0 \text{ V}$, $T_a = -20^\circ\text{C}$ to $+75^\circ\text{C}$
 (regular specifications), $T_a = -40^\circ\text{C}$ to $+85^\circ\text{C}$ (wide-range specifications),
 When programming or erasing flash memory, $T_a = -20^\circ\text{C}$ to $+75^\circ\text{C}$.

| Item | Min. | Typ. | Max. | Unit |
|--|------|------|---------------------------------|---------------|
| Resolution | 10 | 10 | 10 | bit |
| A/D conversion time | — | — | $6.7^{*1}/5.4^{*2}$ | μs |
| Analog input capacitance | — | — | 20 | pF |
| Permitted analog signal source impedance | — | — | 1 | k Ω |
| Non-linear error (reference value) | — | — | $\pm 3.0^{*3*4*5}/\pm 5.0^{*6}$ | LSB |
| Offset error (reference value) | — | — | $\pm 3.0^{*3*4*5}/\pm 5.0^{*6}$ | LSB |
| Full-scale error (reference value) | — | — | $\pm 3.0^{*3*4*5}/\pm 5.0^{*6}$ | LSB |
| Quantization error | — | — | ± 0.5 | LSB |
| Absolute error | — | — | $\pm 4.0^{*3*4*5}/\pm 6.0^{*6}$ | LSB |

- Notes: 1. This is a value when $(CKS1, 0) = (1, 1)$ and $t_{p\text{cyc}} = 50 \text{ ns}$.
 2. This is a value when $(CKS1, 0) = (1, 1)$ and $t_{p\text{cyc}} = 40 \text{ ns}$.
 3. This is a value when $(CKS1, 0) = (1, 1)$, $t_{p\text{cyc}} = 50 \text{ ns}$, and $T_a = -20$ to $+75^\circ\text{C}$ (regular specifications).
 4. This is a value when $(CKS1, 0) = (1, 1)$, $t_{p\text{cyc}} = 40 \text{ ns}$, and $T_a = -20$ to $+75^\circ\text{C}$ (regular specifications).
 5. This is a value when $(CKS1, 0) = (1, 1)$, $t_{p\text{cyc}} = 50 \text{ ns}$, and $T_a = -40$ to $+85^\circ\text{C}$ (wide-range specifications).
 6. This is a value when $(CKS1, 0) = (1, 1)$, $t_{p\text{cyc}} = 40 \text{ ns}$, and $T_a = -40$ to $+85^\circ\text{C}$ (wide-range specifications).

26.5 Flash Memory Characteristics

Table 26.18 shows flash memory characteristics.

Table 26.18 Flash Memory Characteristics

Conditions: $V_{CC} = PLLV_{CC} = 3.3 \text{ V} \pm 0.3 \text{ V}$, $AV_{CC} = 3.3 \text{ V} \pm 0.3 \text{ V}$, $AV_{CC} = V_{CC} \pm 0.3 \text{ V}$,
 $AV_{ref} = 3.0 \text{ V}$ to AV_{CC} , $V_{SS} = PLLV_{SS} = AV_{SS} = 0 \text{ V}$, $T_a = -20^\circ\text{C}$ to $+75^\circ\text{C}$
 (regular specifications^{*6}), $T_a = -40^\circ\text{C}$ to $+85^\circ\text{C}$ (wide-range specifications^{*6}),
 When programming or erasing flash memory, $T_a = -20^\circ\text{C}$ to $+75^\circ\text{C}$.

| Item | Symbol | Min | Typ | Max | Unit | Remarks | |
|--|--|-------------------|---------------------|------|------------------|--------------------------------|----------------------------------|
| Programming time ^{*1, *2, *4} | t_p | — | 10 | 200 | ms/ 128 bytes | | |
| Erase time ^{*1, *3, *5} | t_E | — | 100 | 1200 | ms/block | | |
| Reprogramming count | N_{WEC} | 100 ^{*7} | 10000 ^{*8} | — | Times | Standard product | |
| | N_{WEC} | — | — | 100 | Times | Wide temperature-range product | |
| Data retained time | t_{DRP} | 10 ^{*9} | — | — | years | | |
| Programming | Wait time after SWE bit setting ^{*1} | t_{sswe} | 1 | 1 | — | μs | |
| | Wait time after PSU bit setting ^{*1} | t_{spsu} | 50 | 50 | — | μs | |
| | Wait time after P bit setting ^{*1 *4} | t_{sp30} | 28 | 30 | 32 | μs | Programming time wait |
| | | t_{sp200} | 198 | 200 | 202 | μs | Programming time wait |
| | | t_{sp10} | 8 | 10 | 12 | μs | Additional-programming time wait |
| | Wait time after P bit clear ^{*1} | t_{cp} | 5 | 5 | — | μs | |
| | Wait time after PSU bit clear ^{*1} | t_{cpsu} | 5 | 5 | — | μs | |
| Wait time after PV bit setting ^{*1} | t_{spv} | 4 | 4 | — | μs | | |
| Wait time after H'FF dummy write ^{*1} | t_{spvr} | 2 | 2 | — | μs | | |
| Wait time after PV bit clear ^{*1} | t_{cpv} | 2 | 2 | — | μs | | |
| Wait time after SWE bit clear ^{*1} | t_{cswe} | 100 | 100 | — | μs | | |
| Maximum programming count ^{*1, *4} | N | — | — | 1000 | Times | | |

| Item | | Symbol | Min | Typ | Max | Unit | Remarks |
|-------|--|------------|-----|-----|-----|---------------|-----------------|
| Erase | Wait time after SWE bit setting ^{*1} | t_{sswe} | 1 | 1 | — | μs | |
| | Wait time after ESU bit setting ^{*1} | t_{sesu} | 100 | 100 | — | μs | |
| | Wait time after E bit setting ^{*1 *5} | t_{se} | 10 | 10 | 100 | ms | Erase time wait |
| | Wait time after E bit clear ^{*1} | t_{ce} | 10 | 10 | — | μs | |
| | Wait time after ESU bit clear ^{*1} | t_{cesu} | 10 | 10 | — | μs | |
| | Wait time after EV bit setting ^{*1} | t_{sev} | 20 | 20 | — | μs | |
| | Wait time after H'FF dummy write ^{*1} | t_{sevr} | 2 | 2 | — | μs | |
| | Wait time after EV bit clear ^{*1} | t_{cev} | 4 | 4 | — | μs | |
| | Wait time after SWE bit clear ^{*1} | t_{cswe} | 100 | 100 | — | μs | |
| | Maximum erase count ^{*1 *5} | N | 12 | — | 120 | Times | |

- Notes:
- Make each time setting in accordance with the program/program-verify algorithm or erase/erase-verify algorithm.
 - Programming time per 128 bytes (shows the total period for which the P-bit in the flash memory control register (FLMCR1) is set. It does not include the programming verification time.)
 - 1-Block erase time (shows the total period for which the E-bit in FLMCR1 is set. It does not include the erase verification time.)
 - To specify the maximum programming time value (t_p (max)) in the 128-bytes programming algorithm, set the max. value (1000) for the maximum programming count (N).
The wait time after P bit setting should be changed as follows according to the value of the programming counter (n).
Programming counter (n) = 1 to 6: $t_{sp30} = 30 \mu\text{s}$
Programming counter (n) = 7 to 1000: $t_{sp200} = 200 \mu\text{s}$
[In additional programming]
Programming counter (n) = 1 to 6: $t_{sp10} = 10 \mu\text{s}$
 - For the maximum erase time (t_E (max)), the following relationship applies between the wait time after E bit setting (t_{se}) and the maximum erase count (N):
$$t_E(\text{max}) = \text{Wait time after E bit setting } (t_{se}) \times \text{maximum erase count } (N)$$

To set the maximum erase time, the values of (t_{se}) and (N) should be set so as to satisfy the above formula.
Examples: When $t_{se} = 100 \text{ ms}$, $N = 12 \text{ times}$
When $t_{se} = 10 \text{ ms}$, $N = 120 \text{ times}$
 - See appendix C, Product Code Lineup for correspondence of the standard product, wide temperature-range product, and product model name.
 - All characteristics after rewriting are guaranteed up to this minimum rewriting times (therefore 1 to min. times).
 - Reference value at 25°C (A rough rewriting target number to which a rewriting usually functions)
 - Data retention characteristics when rewriting is executed within the specification values including minimum values.

Appendix A Pin States

A. Pin State

Pin initial states differ according to MCU operating modes. Refer to section 17, Pin Function Controller (PFC), for details.

Table A.1 Pin States (SH7144)

| Pin Function | | Pin State | | | | | | | | |
|------------------------|--------------|-----------------------|-----------------|--------------------|-----------------|--------|------------------|-------|-------------------------|---|
| Type | Pin Name | Reset State | | | | | Power-Down State | | | |
| | | Power-On | | | | | Software Standby | Sleep | Bus Master-ship Release | Software Standby in Bus Master-ship Release |
| | | Expansion without ROM | | Expansion with ROM | Single-chip | Manual | | | | |
| | | 8 bits | 16 bits | | | | | | | |
| Clock | CK | O | O | O | Z | O | H* ¹ | O | O | O |
| | XTAL | O | O | O | O | O | L | O | O | L |
| | EXTAL | I | I | I | I | I | I | I | I | I |
| | PLLCAP | I | I | I | I | I | I | I | I | I |
| System control | RES | I | I | I | I | I | I | I | I | I |
| | MRES | Z | Z | Z | Z | I | Z | I | I | Z |
| | WDTOVF | O* ² | O* ² | O* ² | O* ² | O | O | O | O | O |
| | BREQ | Z | Z | Z | Z | I | Z | I | I | I |
| | BACK | Z | Z | Z | Z | O | Z | O | L | L |
| Operation mode control | MD0 to MD3 | I | I | I | I | I | I | I | I | I |
| | DBGMD | I | I | I | I | I | I | I | I | I |
| | FWP | I | I | I | I | I | I | I | I | I |
| Interrupt | NMI | I | I | I | I | I | I | I | I | I |
| | IRQ0 to IRQ3 | Z | Z | Z | Z | I | Z* ³ | I | I | Z* ³ |
| | IRQ4 to IRQ7 | Z | Z | Z | Z | I | Z* ⁴ | I | I | Z* ⁴ |

A. Pin States

| Pin Function | | Pin State | | | | | | | | |
|--------------|----------------|-----------------------|---------|--------------------|-------------|--------|--|-------|-------------------------|--|
| Type | Pin Name | Reset State | | | | | Power-Down State | | | |
| | | Power-On | | | | | Software Standby | Sleep | Bus Master-ship Release | Software Standby in Bus Master-ship Release |
| | | Expansion without ROM | | Expansion with ROM | Single-chip | Manual | | | | |
| | | 8 bits | 16 bits | | | | | | | |
| Interrupt | IRQOUT | Z | Z | Z | Z | O | Z* ⁶ (MZONE in PPCR=0) H* ¹ (MZONE in PPCR=1) | O | O | Z* ⁶ (MZONE in PPCR=0) H* ¹ (MZONE in PPCR=1) |
| Address bus | A0 to A17 | O | O | Z | Z | O | Z | O | Z | Z |
| | A18 to A21 | Z | Z | Z | Z | O | Z | O | Z | Z |
| Data bus | D0 to D15 | Z | Z | Z | Z | I/O | Z | I/O | Z | Z |
| Bus control | WAIT | Z | Z | Z | Z | I | Z | I | Z | Z |
| | CS0, CS1 | H | H | Z | Z | O | Z | O | Z | Z |
| | CS2, CS3 | Z | Z | Z | Z | O | Z | O | Z | Z |
| | CS6, CS7 | | | | | | | | | |
| | RD | H | H | Z | Z | O | Z | O | Z | Z |
| | WRH, WRL | H | H | Z | Z | O | Z | O | Z | Z |
| DMAC | DREQ0, DREQ1 | Z | Z | Z | Z | I | Z | I | I | Z |
| | DRAK0, DRAK1 | Z | Z | Z | Z | O | O* ¹ | O | O | O* ¹ |
| | DACK0, DACK1 | Z | Z | Z | Z | O | Z (MZONE in PPCR=0) O* ¹ (MZONE in PPCR=1) | O | O | Z (MZONE in PPCR=0) O* ¹ (MZONE in PPCR=1) |
| MTU | TCLKA to TCLKD | Z | Z | Z | Z | I | Z | I | I | Z |

| Pin Function | | Pin State | | | | | | | | | |
|--------------|--|-----------------------|---------|--------------------|-------------|--------|--|-------|-------------------------|--|---|
| Type | Pin Name | Reset State | | | | | Power-Down State | | | | Software Standby in Bus Master-ship Release |
| | | Power-On | | | | | Software Standby | Sleep | Bus Master-ship Release | | |
| | | Expansion without ROM | | Expansion with ROM | Single-chip | Manual | | | | | |
| | | 8 bits | 16 bits | | | | | | | | |
| MTU | TIOC0A to TIOC0D | Z | Z | Z | Z | I/O | K* ¹ | I/O | I/O | K* ¹ | |
| | TIOC1A, TIOC1B | | | | | | | | | | |
| | TIOC2A, TIOC2B | | | | | | | | | | |
| | TIOC3A, TIOC3C | | | | | | | | | | |
| | TIOC3B, TIOC3D | Z | Z | Z | Z | I/O | Z (MZONE in PPCR=0) K* ¹ (MZONE in PPCR=1) | I/O | I/O | Z (MZONE in PPCR=0) K* ¹ (MZONE in PPCR=1) | |
| | TIOC4A to TIOC4D | | | | | | | | | | |
| Port control | $\overline{POE0}$ to $\overline{POE3}$ | Z | Z | Z | Z | I | Z | I | I | Z | |
| SCI | SCK0 to SCK2, SCK3(PE6) SCK3(PE9) | Z | Z | Z | Z | I/O | Z | I/O | I/O | Z | |
| | RXD0 to RXD2, RXD3(PE4) RXD3(PE11) | Z | Z | Z | Z | I | Z | I | I | Z | |
| | TXD0 to TXD2, TXD3(PE5) | Z | Z | Z | Z | O | O* ¹ | O | O | O* ¹ | |
| | TXD3 (PE12) | Z | Z | Z | Z | O | Z* ⁶ (MZONE in PPCR=0) O* ¹ (MZONE in PPCR=1) | O | O | Z* ⁶ (MZONE in PPCR=0) O* ¹ (MZONE in PPCR=1) | |

A. Pin States

| Pin Function | | Pin State | | | | | | | | | |
|------------------|----------------------|-----------------------|---------|--------------------|-------------|--------|--|-------|-------------------------|--|--|
| Type | Pin Name | Reset State | | | | | Power-Down State | | | | |
| | | Power-On | | | | | Software Standby in Bus | | | | |
| | | Expansion without ROM | | Expansion with ROM | Single-chip | Manual | Software Standby | Sleep | Bus Master-ship Release | Master-ship Release | |
| | | 8 bits | 16 bits | | | | | | | | |
| A/D converter | AN0 to AN7 | Z | Z | Z | Z | I | Z | I | I | Z | |
| | ADTRG | Z | Z | Z | Z | I | Z | I | I | Z | |
| I ² C | SCL0 | Z | Z | Z | Z | I/O | Z | I/O | I/O | Z | |
| | SDA0 | Z | Z | Z | Z | I/O | Z | I/O | I/O | Z | |
| I/O port | PA0 to PA15 | Z | Z | Z | Z | I/O | K* ¹ | I/O | I/O | K* ¹ | |
| | PB0 to PB9 | | | | | | | | | | |
| | PC0 to PC15 | | | | | | | | | | |
| | PD0 to PD15 | | | | | | | | | | |
| | PE0 to PE8, PE10 | | | | | | | | | | |
| | PE9, PE11 to PE15 | Z | Z | Z | Z | I/O | Z (MZONE in PPCR=0) K* ¹ (MZONE in PPCR=1) | I/O | I/O | Z (MZONE in PPCR=0) K* ¹ (MZONE in PPCR=1) | |
| | PF0 to PF7 | Z | Z | Z | Z | I | Z | I | I | Z | |

[Legend]

- I: Input
- O: Output
- H: High-level output
- L: Low-level output
- Z: High-impedance
- K: Input pins become high-impedance, and output pins retain their state.

Table A.2 Pin States (SH7145)

| Pin Function | | Pin State | | | | | | | | |
|------------------------|--|-----------------------|-----------------|--------------------|-----------------|--------|--|-------|-------------------------|--|
| Type | Pin Name | Reset State | | | | | Power-Down State | | | |
| | | Power-On | | | | | Software Standby | Sleep | Bus Master-ship Release | Software Standby in Bus Master-ship Release |
| | | Expansion without ROM | | Expansion with ROM | Single-chip | Manual | | | | |
| | | 8 bits | 16 bits | | | | | | | |
| Clock | CK | O | O | O | Z | O | H* ¹ | O | O | O |
| | XTAL | O | O | O | O | O | L | O | O | L |
| | EXTAL | I | I | I | I | I | I | I | I | I |
| | PLLCAP | I | I | I | I | I | I | I | I | I |
| System control | $\overline{\text{RES}}$ | I | I | I | I | I | I | I | I | I |
| | $\overline{\text{MRES}}$ | Z | Z | Z | Z | I | Z | I | I | Z |
| | $\overline{\text{WDTOVF}}$ | O* ² | O* ² | O* ² | O* ² | O | O | O | O | O |
| | $\overline{\text{BREQ}}$ | Z | Z | Z | Z | I | Z | I | I | I |
| | $\overline{\text{BACK}}$ | Z | Z | Z | Z | O | Z | O | L | L |
| Operation mode control | MD0 to MD3 | I | I | I | I | I | I | I | I | I |
| | DBGMD | I | I | I | I | I | I | I | I | I |
| | FWP | I | I | I | I | I | I | I | I | I |
| Interrupt | NMI | I | I | I | I | I | I | I | I | I |
| | $\overline{\text{IRQ0}}$ to $\overline{\text{IRQ3}}$ | Z | Z | Z | Z | I | Z* ³ | I | I | Z* ³ |
| | $\overline{\text{IRQ4}}$ to $\overline{\text{IRQ7}}$ | Z | Z | Z | Z | I | Z* ⁴ | I | I | Z* ⁴ |
| | $\overline{\text{IRQOUT}}$ (PD30) | Z | Z | Z | Z | O | H* ¹ | O | O | H* ¹ |
| | $\overline{\text{IRQOUT}}$ (PE15) | Z | Z | Z | Z | O | Z* ⁶ (MZIZE in PPCR=0) H* ¹ (MZIZE in PPCR=1) | O | O | Z* ⁶ (MZIZE in PPCR=0) H* ¹ (MZIZE in PPCR=1) |
| Address bus | A0 to A17 | O | O | Z | Z | O | Z | O | Z | Z |
| | A18 to A21 | Z | Z | Z | Z | O | Z | O | Z | Z |
| Data bus | D0 to D31 | Z | Z | Z | Z | I/O | Z | I/O | Z | Z |

A. Pin States

| Pin Function | | Pin State | | | | | | | | |
|--------------|----------------------------|-----------------------|---------|--------------------|-------------|--------|--|-------|-------------------------|--|
| Type | Pin Name | Reset State | | | | | Power-Down State | | | |
| | | Power-On | | | | | Software Standby | Sleep | Bus Master-ship Release | Software Standby in Bus Master-ship Release |
| | | Expansion without ROM | | Expansion with ROM | Single-chip | Manual | | | | |
| | | 8 bits | 16 bits | | | | | | | |
| Bus control | WAIT | Z | Z | Z | Z | I | Z | I | Z | Z |
| | CS0, CS1 | H | H | Z | Z | O | Z | O | Z | Z |
| | CS2, to CS7 | Z | Z | Z | Z | O | Z | O | Z | Z |
| | RD | H | H | Z | Z | O | Z | O | Z | Z |
| | WRH, WRL | H | H | Z | Z | O | Z | O | Z | Z |
| | WRHH, WRHL | Z | H | Z | Z | O | Z | O | Z | Z |
| DMAC | DREQ0, DREQ1 | Z | Z | Z | Z | I | Z | I | I | Z |
| | DRAK0, DRAK1 | Z | Z | Z | Z | O | O* ¹ | O | O | O* ¹ |
| | DACK0 (PD26), DACK1 (PD27) | Z | Z | Z | Z | O | O* ^{1&5} | O | O | O* ^{1&5} |
| | DACK0 (PE14), DACK1 (PE15) | Z | Z | Z | Z | O | Z (MZONE in PPCR=0) O* ¹ (MZONE in PPCR=1) | O | O | Z (MZONE in PPCR=0) O* ¹ (MZONE in PPCR=1) |
| MTU | TCLKA to TCLKD | Z | Z | Z | Z | I | Z | I | I | Z |
| | TIOC0A to TIOC0D | Z | Z | Z | Z | I/O | K* ¹ | I/O | I/O | K* ¹ |
| | TIOC1A, TIOC1B | | | | | | | | | |
| | TIOC2A, TIOC2B | | | | | | | | | |
| | TIOC3A, TIOC3C | | | | | | | | | |

| Pin Function | | Pin State | | | | | | | | |
|------------------|---|-----------------------|---------|-----------|---------|----------|--|-------------|--------------|--|
| | | Reset State | | | | | Power-Down State | | | |
| | | Power-On | | | | | | | | |
| | | Expansion without ROM | | Expansion | Single- | Software | | Bus Master- | | Software |
| Type | Pin Name | 8 bits | 16 bits | with ROM | chip | Manual | Standby | Sleep | ship Release | Standby in Bus Master- ship Release |
| MTU | TIOC3B, TIOC3D | Z | Z | Z | Z | I/O | Z (MZONE in PPCR=0) | I/O | I/O | Z (MZONE in PPCR=0) |
| | TIOC4A to TIOC4D | | | | | | K* ¹ (MZONE in PPCR=1) | | | K* ¹ (MZONE in PPCR=1) |
| Port control | $\overline{\text{POE0}}$ to $\overline{\text{POE3}}$ | Z | Z | Z | Z | I | Z | I | I | Z |
| SCI | SCK0 to SCK2, SCK3(PE6) SCK3(PE9) | Z | Z | Z | Z | I/O | Z | I/O | I/O | Z |
| | RXD0 to RXD2, RXD3(PE4) RXD3(PE11) | Z | Z | Z | Z | I | Z | I | I | Z |
| | TXD0 to TXD2, TXD3(PE5) | Z | Z | Z | Z | O | O* ¹ | O | O | O* ¹ |
| | TXD3 (PE12) | Z | Z | Z | Z | O | Z* ⁵ (MZONE in PPCR=0) O* ¹ (MZONE in PPCR=1) | O | O | Z* ⁵ (MZONE in PPCR=0) O* ¹ (MZONE in PPCR=1) |
| A/D converter | AN0 to AN7 | Z | Z | Z | Z | I | Z | I | I | Z |
| | ADTRG | Z | Z | Z | Z | I | Z | I | I | Z |
| I ² C | SCL0 | Z | Z | Z | Z | I/O | Z | I/O | I/O | Z |
| | SDA0 | Z | Z | Z | Z | I/O | Z | I/O | I/O | Z |

A. Pin States

| Pin Function | | Pin State | | | | | | | | |
|--------------|-------------------|-----------------------|---------|--------------------|-------------|--------|--|-------|-------------------------|--|
| | | Reset State | | | | | Power-Down State | | | |
| Type | Pin Name | Power-On | | | | Manual | Software Standby | Sleep | Bus Master-ship Release | Software Standby in Bus Master-ship Release |
| | | Expansion without ROM | | Expansion with ROM | Single-chip | | | | | |
| | | 8 bits | 16 bits | | | | | | | |
| I/O port | PA0 to PA23 | Z | Z | Z | Z | I/O | K* ¹ | I/O | I/O | K* ¹ |
| | PB0 to PB9 | | | | | | | | | |
| | PC0 to PC15 | | | | | | | | | |
| | PD0 to PD31 | | | | | | | | | |
| | PE0 to PE8, PE10 | | | | | | | | | |
| | PE9, PE11 to PE15 | Z | Z | Z | Z | I/O | Z (MZONE in PPCR=0) K* ¹ (MZONE in PPCR=1) | I/O | I/O | Z (MZONE in PPCR=0) K* ¹ (MZONE in PPCR=1) |
| | PF0 to PF7 | Z | Z | Z | Z | I | Z | I | I | Z |

[Legend]

- I: Input
- O: Output
- H: High-level output
- L: Low-level output
- Z: High impedance
- K: Input pins become high-impedance, and output pins retain their state.

Table A.3 Pin States

| Pin Function | | Pin State | | | | | | |
|--------------|----------|--------------------|--------------------|--------|------------|------------------|-------|---------------|
| Type | Pin Name | Reset | | | Power-down | | | No Connection |
| | | Power-On (DBGMD=L) | Power-On (DBGMD=H) | Manual | Test Reset | Software Standby | Sleep | |
| H-UDI | TMS | Z | I | I | I | I | I | Prohibited |
| | TRST | Z | I | I | I | I | I | Prohibited |
| | TDI | Z | I | I | I | I | I | Prohibited |
| | TDO | Z | O/Z | O/Z | Z | O/Z | O/Z | O/Z |
| | TCK | Z | I | I | I | I | I | Prohibited |

Table A.4 Pin States

| Pin Function | | Pin State | | | | | | |
|--------------|-----------------------------|-----------|---|---|---|---|--------------------|---------------|
| Type | Pin Name | Reset | | | Power-down | | | No Connection |
| | | Power-On | Manual | AUD Reset | Software Standby | Sleep | AUD Module Standby | |
| AUD | $\overline{\text{AUDRST}}$ | Z | High-level input | Low-level input | High-level input | High-level input | Z | Prohibited |
| | AUDMD | Z | I | I | I | I | Z | Prohibited |
| | AUDATA0 to AUDATA3 | Z | AUDMD = High: I/O AUDMD = Low: O | AUDMD = High: I AUDMD = Low: H | AUDMD = High: I/O AUDMD = Low: O | AUDMD = High: I/O AUDMD = Low: O | Z | Prohibited |
| | AUDCK | Z | AUDMD = High: I AUDMD = Low: O | AUDMD = High: I AUDMD = Low: H | AUDMD = High: I AUDMD = Low: O | AUDMD = High: I AUDMD = Low: O | Z | Prohibited |
| | $\overline{\text{AUDSYNC}}$ | Z | AUDMD = High: I AUDMD = Low: O | AUDMD = High: I AUDMD = Low: H | AUDMD = High: I AUDMD = Low: O | AUDMD = High: I AUDMD = Low: O | Z | Prohibited |

Table A.5 Pin States

| Pin Function | | Pin State | | | | |
|------------------------|----------|-------------------------|-------------------------|------------|------------------|-------|
| | | Reset | | Power-down | | |
| Type | Pin Name | Power-On (DBGMD = L) | Power-On (DBGMD = H) | Manual | Software Standby | Sleep |
| Operating mode control | ASEBRKAK | Z | O | O | O | O |

[Legend]

I: Input

O: Output

H: High-level output

L: Low-level output

Z: High impedance

K: Input pins become high-impedance, and output pins retain their state.

- Notes:
1. When the Hi-Z bit in SBYCR is set to 1, the output pins enter their high-impedance state.
 2. This pin operates as an input pin during power-on reset period. This pin should be pulled up to prevent malfunction. In this case, the resistance value must be 1M Ω or higher.
 3. This pin operates as an input pin when the IRQEL bit in SBYCR is set to 0.
 4. This pin operates as an input pin when the IRQEH bit in SBYCR is set to 0.
 5. This pin becomes high-impedance in the emulator.
 6. In the emulator, this pin operates as an input pin when the Hi-Z bit in SBYCR is set to 0.

Appendix B Pin States of Bus Related Signals

B. Pin States of Bus Related Signals

Table B.1 Pin States of Bus Related Signals (1)

| Pin Name | On-chip Peripheral Module | | | | | |
|--------------------------------------|---------------------------|-------------------|-------------|--------------|------------|---------------|
| | On-chip ROM Space | On-chip RAM Space | 8-bit Space | 16-bit Space | | |
| | | | | Upper Byte | Lower Byte | Word/Longword |
| $\overline{CS0}$ to $\overline{CS7}$ | H | H | H | H | H | H |
| \overline{RD} | R H | H | H | H | H | H |
| | W — | H | H | H | H | H |
| \overline{WRHH} | R H | H | H | H | H | H |
| | W — | H | H | H | H | H |
| \overline{WRHL} | R H | H | H | H | H | H |
| | W — | H | H | H | H | H |
| \overline{WRH} | R H | H | H | H | H | H |
| | W — | H | H | H | H | H |
| \overline{WRL} | R H | H | H | H | H | H |
| | W — | H | H | H | H | H |
| A21 to A0 | Address | Address | Address | Address | Address | Address |
| D31 to D24 | Hi-Z | Hi-Z | Hi-Z | Hi-Z | Hi-Z | Hi-Z |
| D23 to D16 | Hi-Z | Hi-Z | Hi-Z | Hi-Z | Hi-Z | Hi-Z |
| D15 to D8 | Hi-Z | Hi-Z | Hi-Z | Hi-Z | Hi-Z | Hi-Z |
| D7 to D0 | Hi-Z | Hi-Z | Hi-Z | Hi-Z | Hi-Z | Hi-Z |

[Legend]

R: Read

W: Write

Enabled: Chip select signals corresponding to accessed areas = Low
The other chip select signals = High

Table B.1 Pin States of Bus Related Signals (2)

| Pin Name | Normal External Space | | | |
|--------------------------------------|-----------------------|--------------|------------|---------------|
| | 8-bit Space | 16-bit Space | | |
| | | Upper Byte | Lower Byte | Word/Longword |
| $\overline{CS0}$ to $\overline{CS7}$ | Enabled | Enabled | Enabled | Enabled |
| \overline{RD} | R L | L | L | L |
| | W H | H | H | H |
| WRHH | R H | H | H | H |
| | W H | H | H | H |
| \overline{WRHL} | R H | H | H | H |
| | W H | H | H | H |
| \overline{WRH} | R H | H | H | H |
| | W H | L | H | L |
| \overline{WRL} | R H | H | H | H |
| | W L | H | L | L |
| A21 to A0 | Address | Address | Address | Address |
| D31 to D24 | Hi-Z | Hi-Z | Hi-Z | Hi-Z |
| D23 to D16 | Hi-Z | Hi-Z | Hi-Z | Hi-Z |
| D15 to D8 | Hi-Z | Data | Hi-Z | Data |
| D7 to D0 | Data | Hi-Z | Data | Data |

[Legend]

R: Read

W: Write

Enabled: Chip select signals corresponding to accessed areas = Low
 The other chip select signals = High

Table B.1 Pin States of Bus Related Signals (3)

| Pin Name | Normal External Space | | | | | | | |
|--------------------------------------|-----------------------|-------------|------------|------------------------|------------|------------|----------|--|
| | 32-bit Space | | | | | | | |
| | Most Significant Byte | Second Byte | Third Byte | Least Significant Byte | Upper Word | Lower Word | Longword | |
| $\overline{CS0}$ to $\overline{CS7}$ | Enabled | Enabled | Enabled | Enabled | Enabled | Enabled | Enabled | |
| \overline{RD} | R | L | L | L | L | L | L | |
| | W | H | H | H | H | H | H | |
| \overline{WRHH} | R | H | H | H | H | H | H | |
| | W | L | H | H | H | L | L | |
| \overline{WRHL} | R | H | H | H | H | H | H | |
| | W | H | L | H | H | L | L | |
| \overline{WRH} | R | H | H | H | H | H | H | |
| | W | H | H | L | H | H | L | |
| \overline{WRL} | R | H | H | H | H | H | H | |
| | W | H | H | H | L | H | L | |
| A21 to A0 | Address | Address | Address | Address | Address | Address | Address | |
| D31 to D24 | Data | Hi-Z | Hi-Z | Hi-Z | Data | Hi-Z | Data | |
| D23 to D16 | Hi-Z | Data | Hi-Z | Hi-Z | Data | Hi-Z | Data | |
| D15 to D8 | Hi-Z | Hi-Z | Data | Hi-Z | Hi-Z | Data | Data | |
| D7 to D0 | Hi-Z | Hi-Z | Hi-Z | Data | Hi-Z | Data | Data | |

[Legend]

R: Read

W: Write

Enabled: Chip select signals corresponding to accessed areas = Low
 The other chip select signals = High

Appendix C Product Code Lineup

| Product Type | | | Part No. | Package (Package Code) | | |
|--------------------|----------------------|--|--------------------------------|---------------------------|---------------|--------------------|
| SH7144 | Flash memory version | Standard product | HD64F7144F50 | QFP-112 (FP-112B) | | |
| | | Wide temperature range product | HD64F7144FW50 | | | |
| | Masked ROM version | Standard product | HD6437144F50 | | | |
| | | Wide temperature range product | HD6437144FW50 | | | |
| | | I ² C bus interface function product | HD6437144WF50 | | | |
| | | I ² C bus interface function/wide temperature range product | HD6437144WFW50 | | | |
| | ROM less version | Standard product | HD6417144F50 | | | |
| | | Wide temperature range product | HD6417144FW50 | | | |
| | SH7145 | Flash memory version | Standard product | | HD64F7145F50 | LQFP-144 (FP-144F) |
| | | | Wide temperature range product | | HD64F7145FW50 | |
| Masked ROM version | | Standard product | HD6437145F50 | | | |
| | | Wide temperature range product | HD6437145FW50 | | | |
| | | I ² C bus interface function product | HD6437145WF50 | | | |
| | | I ² C bus interface function/wide temperature range product | HD6437145WFW50 | | | |
| ROM less version | | Standard product | HD6417145F50 | | | |
| | | Wide temperature range product | HD6417145FW50 | | | |

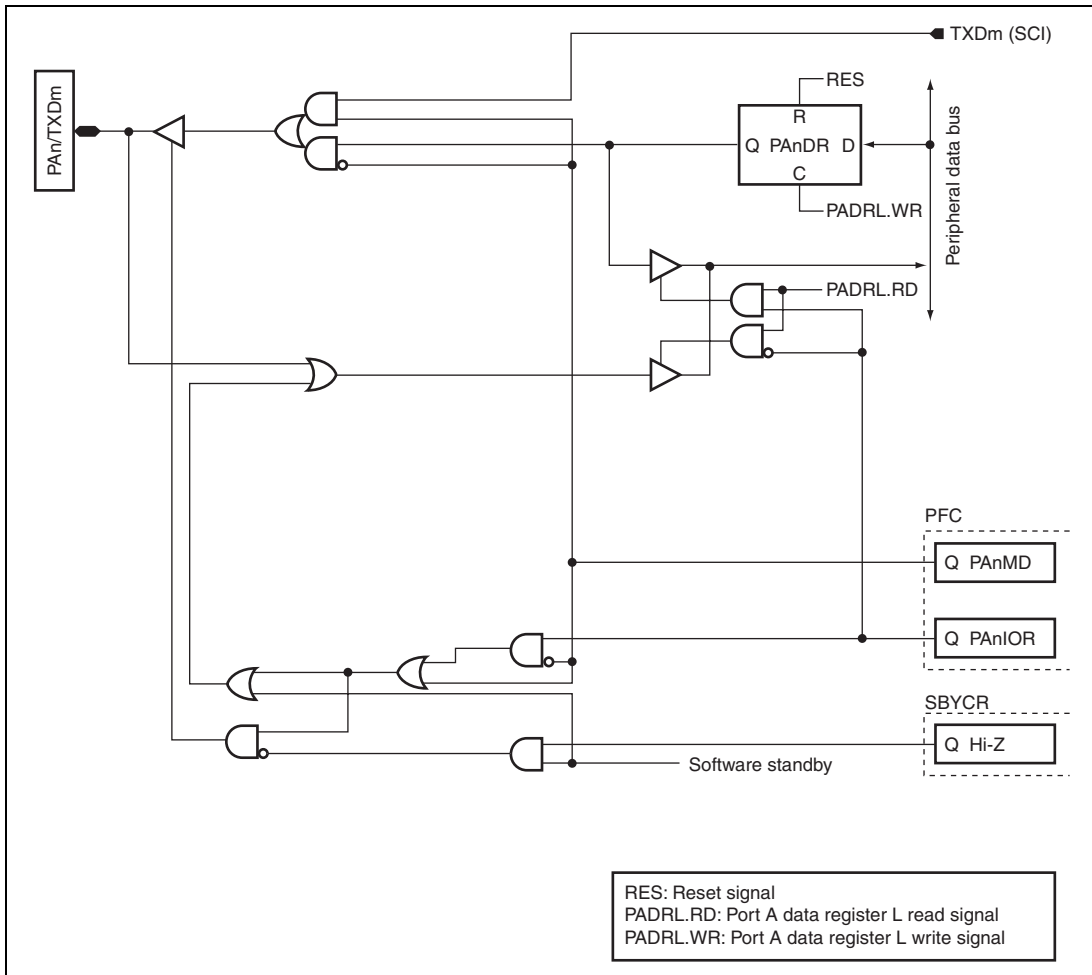

Figure D.2 PA n/TXD m

| Symbol in Figure D.2 | | Available Products | | | | |
|----------------------|-----|--------------------|----------------|---|----------------|---|
| | | SH7144 | | SH7145 | | |
| Pins | PAn | TXDm | F-ZTAT version | Masked ROM version/ ROM less version | F-ZTAT version | Masked ROM version/ ROM less version |
| PA1/TXD0 | PA1 | TXD0 (SCI) | √ | √ | √ | √ |
| PA4/TXD1 | PA4 | TXD1 (SCI) | √ | √ | √ | √ |

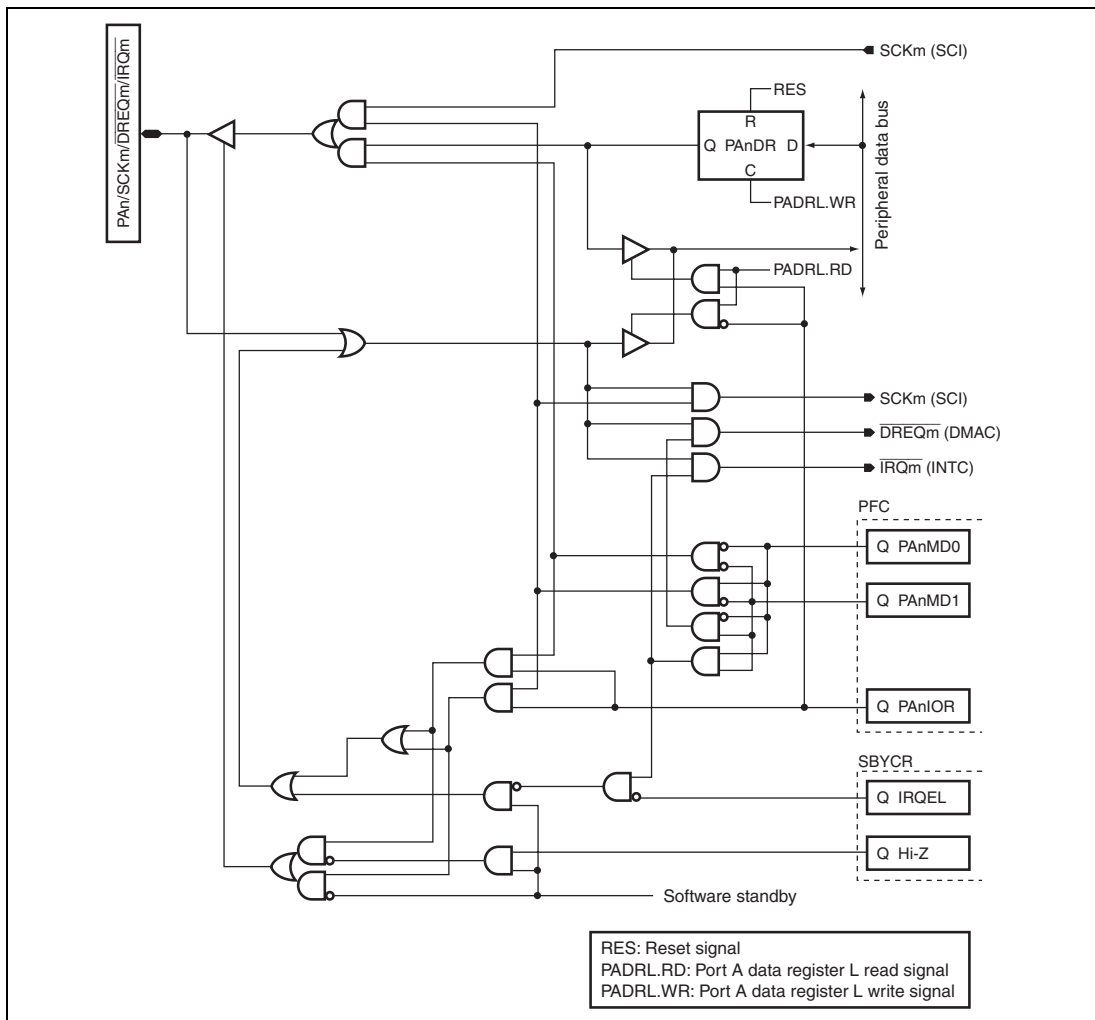

Figure D.3 PA n/SCKm/DREQm/IRQm

Symbol in Figure D.3

Available Products

| Pins | PA n | SCKm | DREQm | IRQm | F-ZTAT version | SH7144 | | SH7145 | |
|---------------|------|----------------|--------------|------|-------------------|---|---|--------|---|
| | | | | | | Masked ROM version/ ROM less version | Masked ROM version/ ROM less version | | |
| PA6/TCLKA/CS2 | PA6 | TCLKA (MTU) | CS2 (BSC) | √ | √ | √ | √ | √ | √ |
| PA7/TCLKB/CS3 | PA7 | TCLKB (MTU) | CS3 (BSC) | √ | √ | √ | √ | √ | √ |

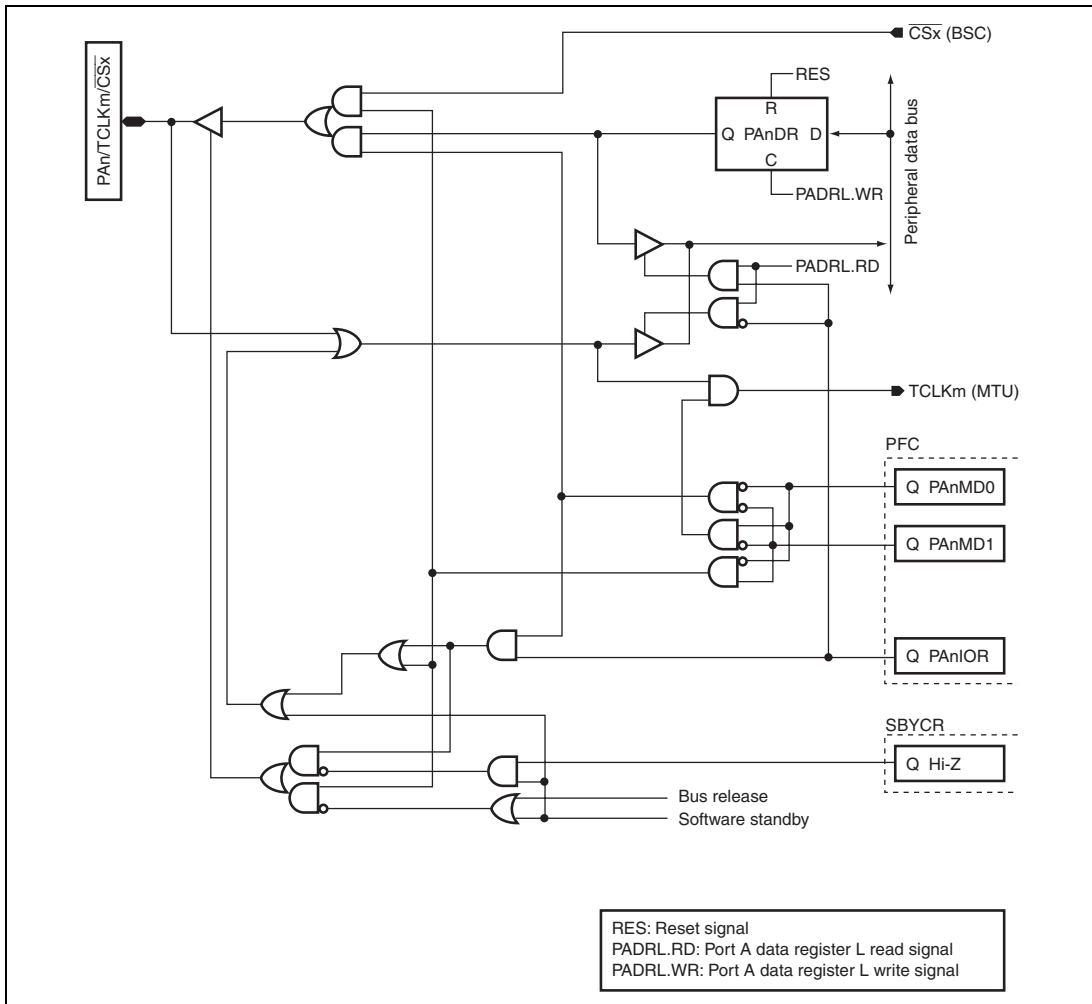
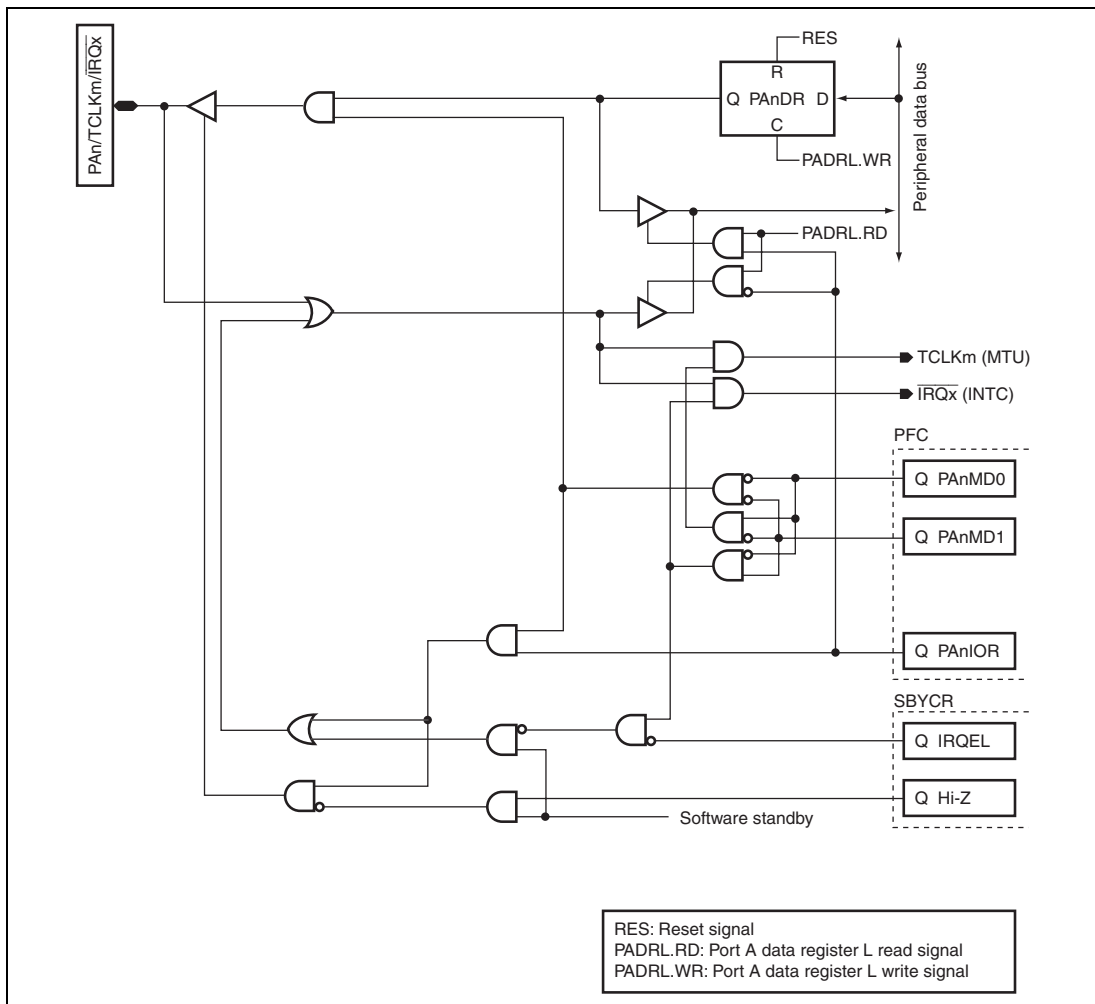

Figure D.4 PAn/TCLKm/CSx

Symbol in Figure D.4

Available Products

| Pins | PAn | TCLKm | CSx | Available Products | | | |
|---------------|-----|-------------|-----------|--------------------|---|----------------|---|
| | | | | F-ZTAT version | SH7144 Masked ROM version/ ROM less version | F-ZTAT version | SH7145 Masked ROM version/ ROM less version |
| PA6/TCLKA/CS2 | PA6 | TCLKA (MTU) | CS2 (BSC) | √ | √ | √ | √ |
| PA7/TCLKB/CS3 | PA7 | TCLKB (MTU) | CS3 (BSC) | √ | √ | √ | √ |

Figure D.5 PA_n/TCLK_m/IRQ_x

Symbol in Figure D.5

Available Products

| Pins | PA _n | TCLK _m | IRQ _x | Available Products | | | |
|----------------|-----------------|-------------------|------------------|--------------------|---|----------------|---|
| | | | | F-ZTAT version | Masked ROM version/ ROM less version | F-ZTAT version | Masked ROM version/ ROM less version |
| PA8/TCLKC/IRQ2 | PA8 | TCLKC (MTU) | IRQ2 (INTC) | √ | √ | √ | √ |
| PA9/TCLKD/IRQ3 | PA9 | TCLKD (MTU) | IRQ3 (INTC) | √ | √ | √ | √ |

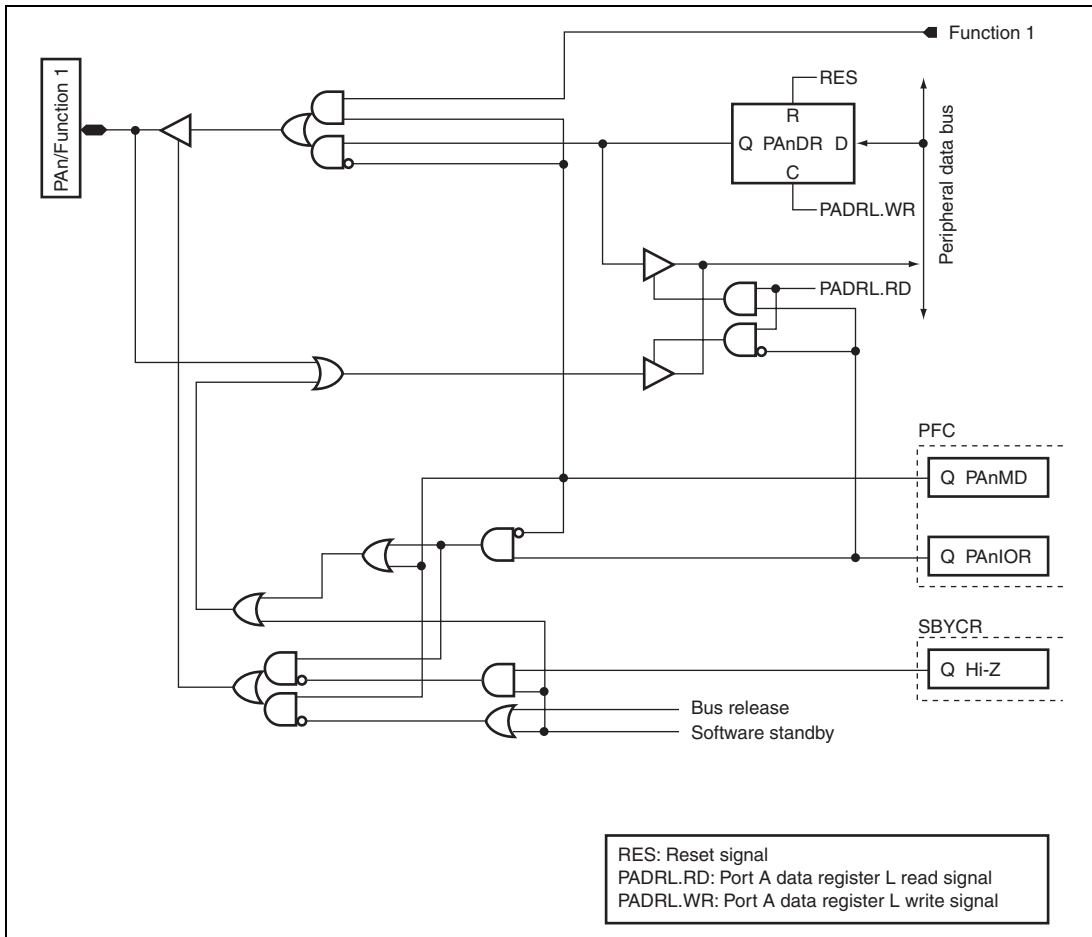

Figure D.6 PA n/Function 1

Symbol in Figure D.6

Available Products

| Pins | PAn | Function 1 | Available Products | | | |
|------------------------|------|------------------------|--------------------|---|---|----------------|
| | | | F-ZTAT version | SH7144 Masked ROM version/ ROM less version | SH7145 Masked ROM version/ ROM less version | F-ZTAT version |
| PA10/ $\overline{CS0}$ | PA10 | $\overline{CS0}$ (BSC) | √ | √ | √ | √ |
| PA11/ $\overline{CS1}$ | PA11 | $\overline{CS1}$ (BSC) | √ | √ | √ | √ |
| PA12/ \overline{WRL} | PA12 | \overline{WRL} (BSC) | √ | √ | √ | √ |
| PA13/ \overline{WRH} | PA13 | \overline{WRH} (BSC) | √ | √ | √ | √ |
| PA14/ \overline{RD} | PA14 | \overline{RD} (BSC) | √ | √ | √ | √ |

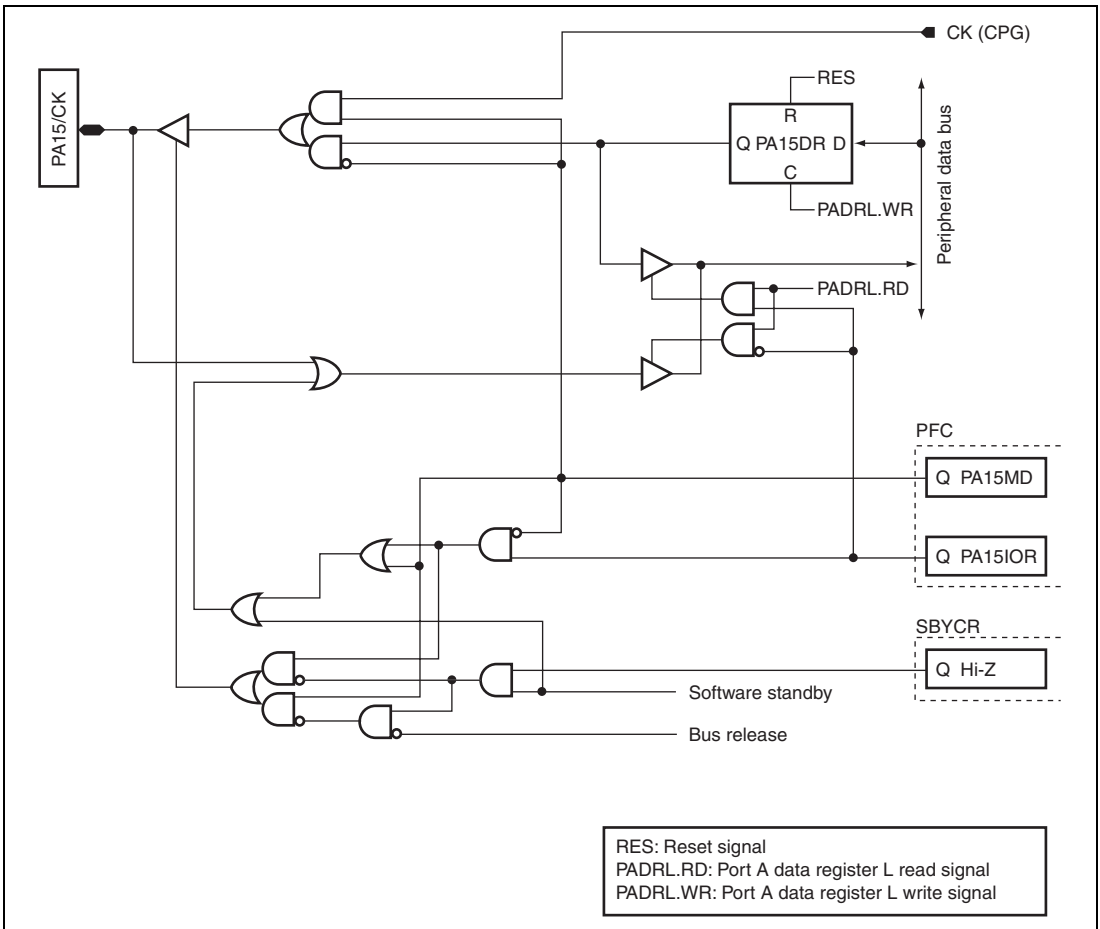

Figure D.7 PA15/CK

Symbol in Figure D.7

Available Products

| Pins | PA15 | CK | F-ZTAT version | Available Products | |
|---------|------|----------|-------------------|---|---|
| | | | | SH7144 | SH7145 |
| | | | | Masked ROM version/ ROM less version | Masked ROM version/ ROM less version |
| PA15/CK | PA15 | CK (CPG) | √ | √ | √ |

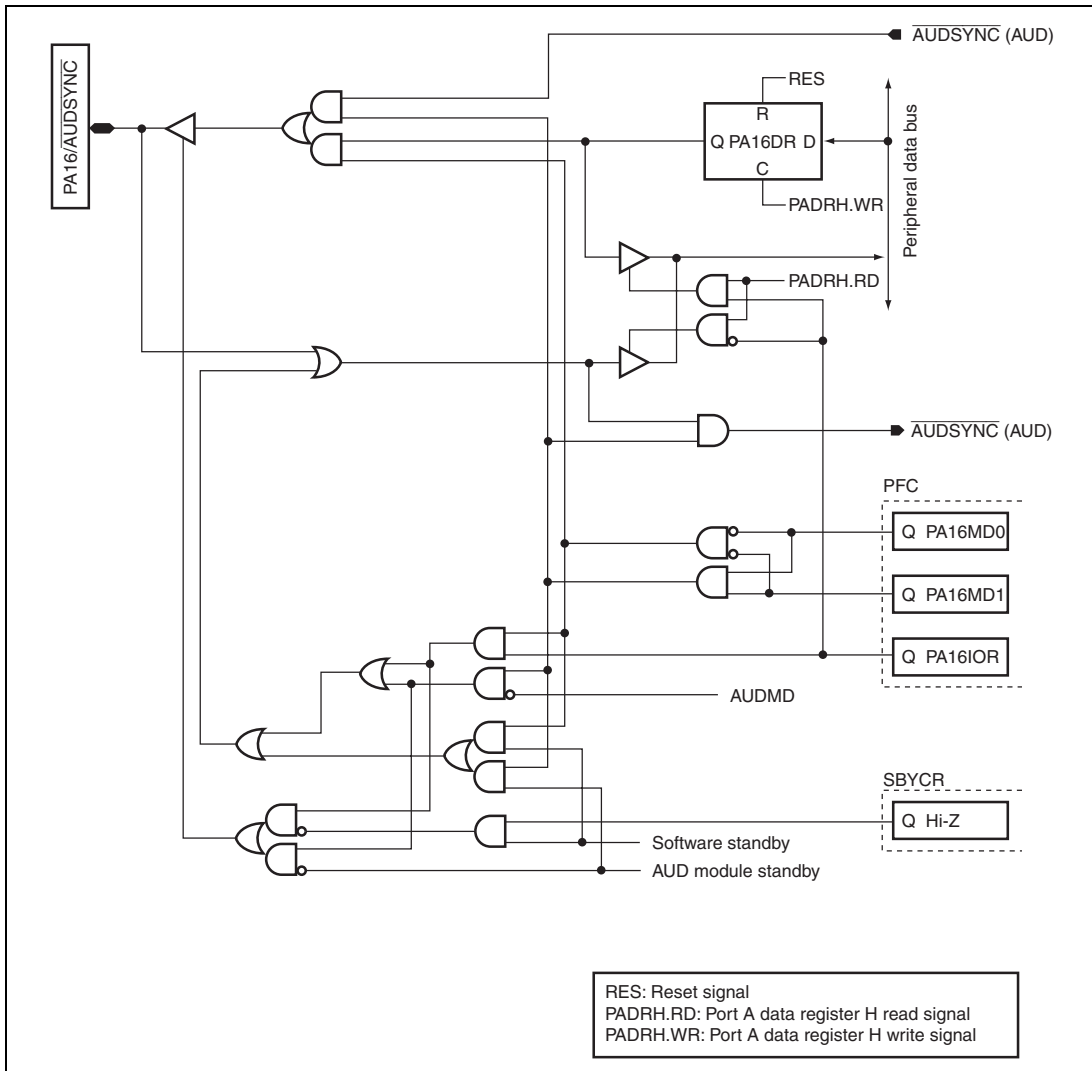

Figure D.8 PA16/AUDSYNC

| Symbol in Figure D.8 | | Available Products | | | |
|----------------------|--------------------------|--------------------|---|----------------|---|
| | | SH7144 | | SH7145 | |
| Pins | PA16 | F-ZTAT version | Masked ROM version/ ROM less version | F-ZTAT version | Masked ROM version/ ROM less version |
| PA16/AUDSYNC | PA16 AUDSYNC (AUD) | — | — | √ | — |

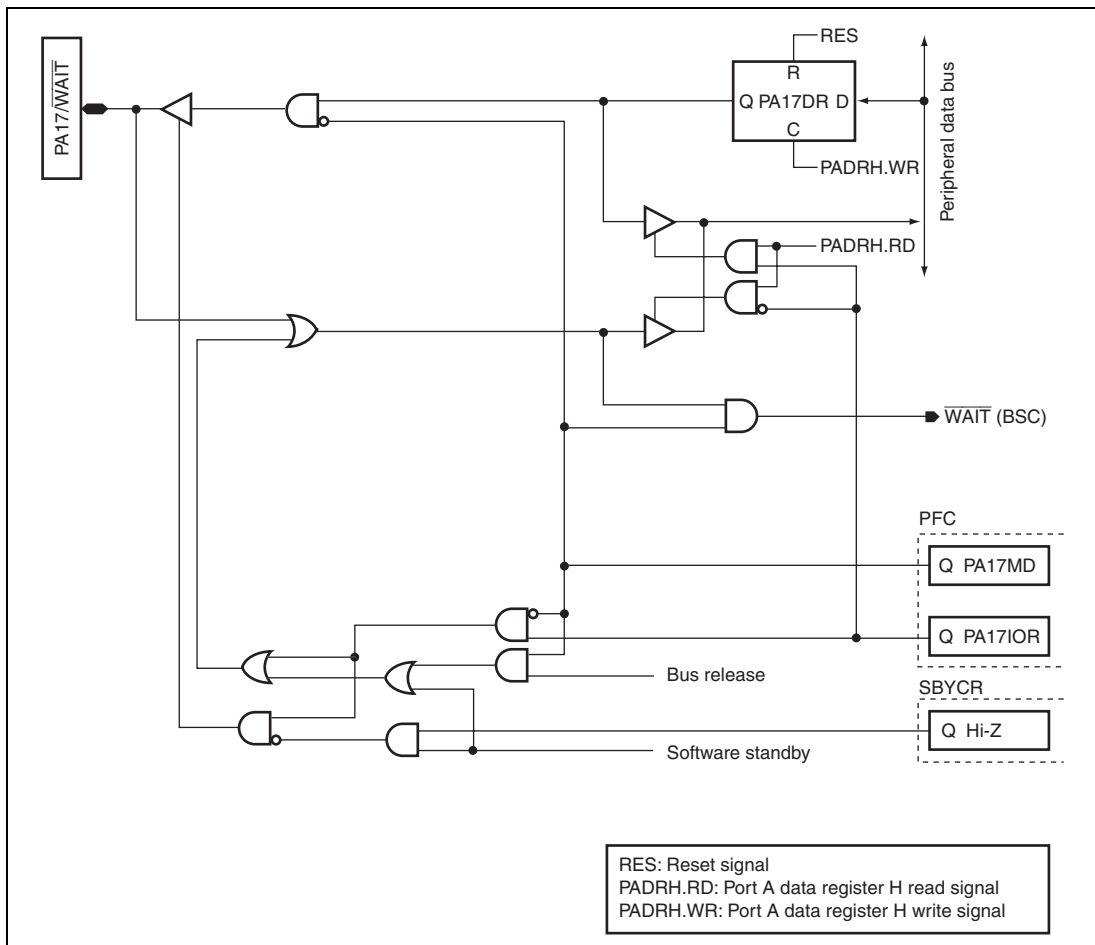

Figure D.9 PA17/ $\overline{\text{WAIT}}$

Symbol in Figure D.9

Available Products

| Pins | PA17 | $\overline{\text{WAIT}}$ | SH7144 | | SH7145 | |
|--------------------------------|------|--------------------------------|----------------|---|----------------|---|
| | | | F-ZTAT version | Masked ROM version/ ROM less version | F-ZTAT version | Masked ROM version/ ROM less version |
| PA17/ $\overline{\text{WAIT}}$ | PA17 | $\overline{\text{WAIT}}$ (BSC) | — | — | √ | √ |

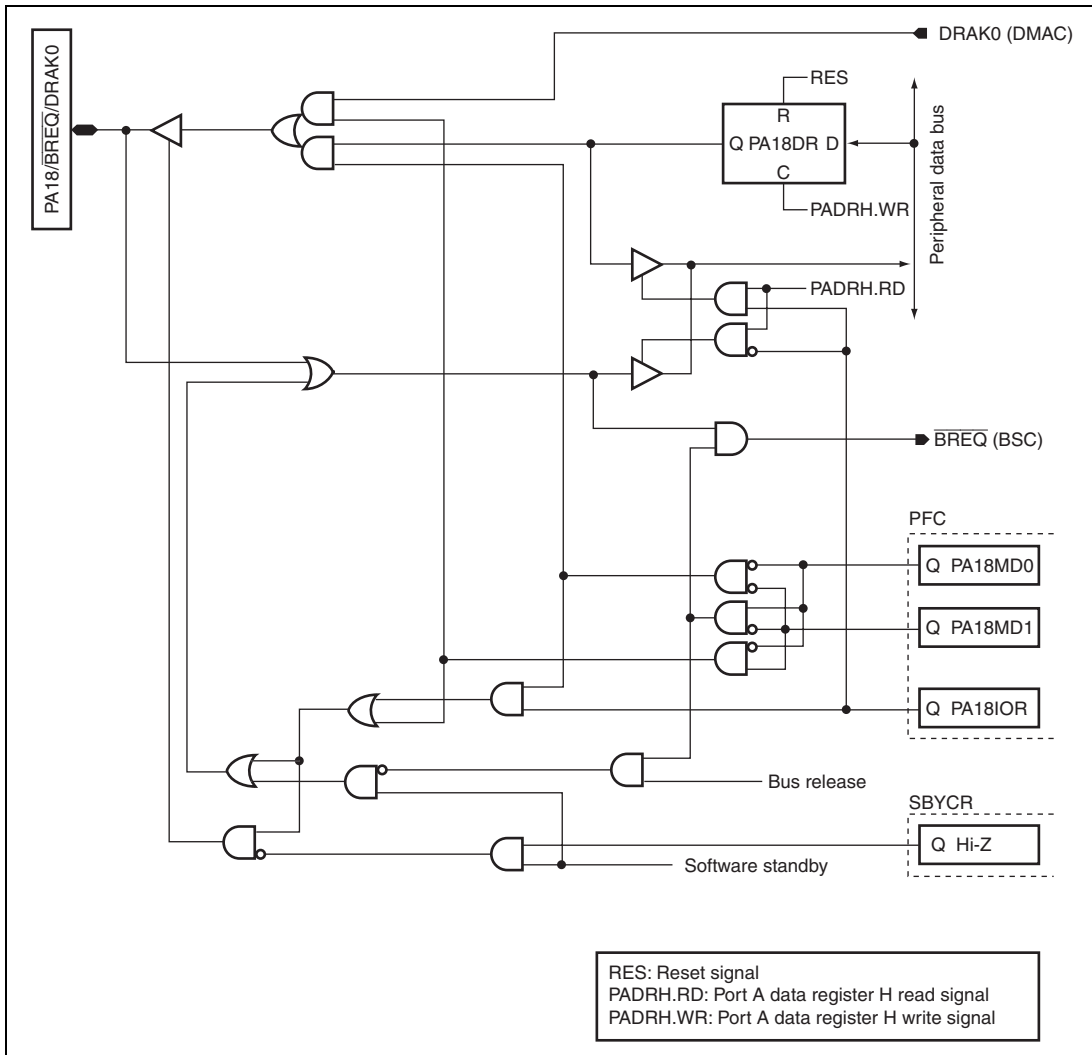

Figure D.10 PA18/BREQ/DRAK0

Symbol in Figure D.10

Available Products

| Pins | PA18 | BREQ | DRAK0 | Available Products | | | | | |
|-----------------|------|------------|--------------|--------------------|---|---|----------------|---|---|
| | | | | F-ZTAT version | SH7144 | SH7145 | F-ZTAT version | | |
| PA18/BREQ/DRAK0 | PA18 | BREQ (BSC) | DRAK0 (DMAC) | — | Masked ROM version/ ROM less version | Masked ROM version/ ROM less version | — | √ | √ |

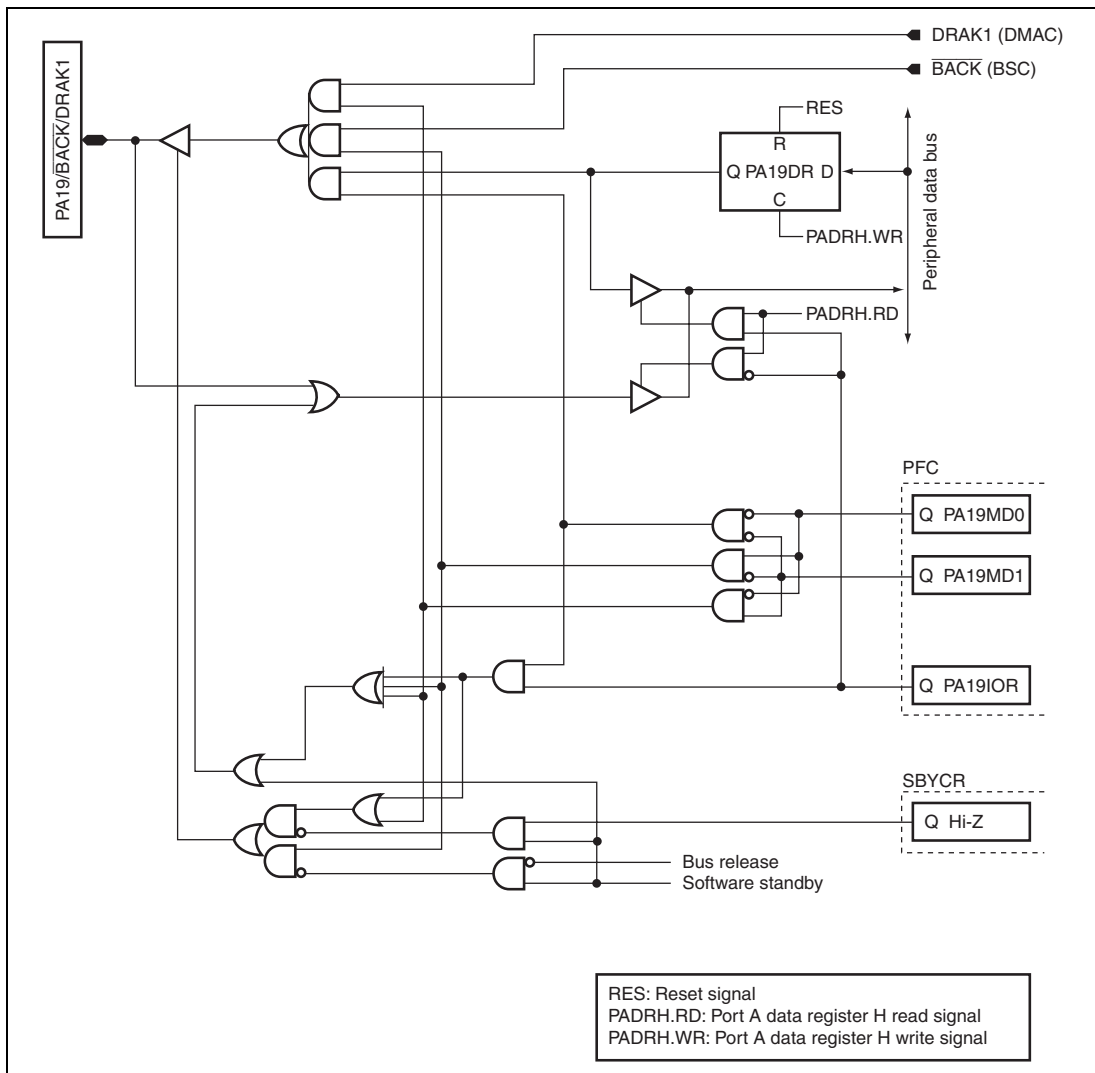

Figure D.11 PA19/BACK/DRAK1

| Symbol in Figure D.11 | | | | Available Products | | | |
|-----------------------|------|---------------|-----------------|--------------------|---|----------------|---|
| | | | | SH7144 | | SH7145 | |
| Pins | PA19 | BACK | DRAK1 | F-ZTAT version | Masked ROM version/ ROM less version | F-ZTAT version | Masked ROM version/ ROM less version |
| PA19/BACK/ DRAK1 | PA19 | BACK (BSC) | DRAK1 (DMAC) | — | — | √ | √ |

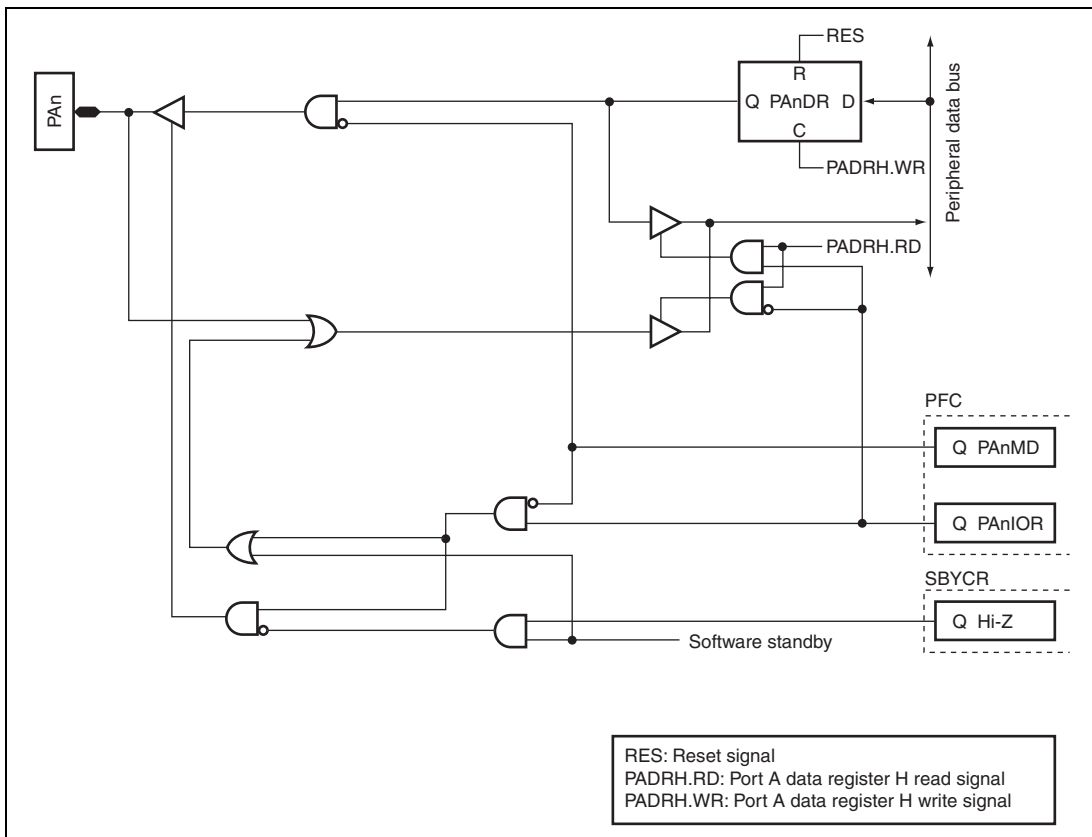

Figure D.12 PA_n

Symbol in Figure D.12

Available Products

| Pins | PA _n | PA _n MD | SH7144 | | SH7145 | |
|------|-----------------|--------------------|----------------|---|----------------|---|
| | | | F-ZTAT version | Masked ROM version/ ROM less version | F-ZTAT version | Masked ROM version/ ROM less version |
| PA16 | PA16 | PA16MD0 | — | — | — | √ |
| PA20 | PA20 | PA20MD | — | — | √ | — |
| PA21 | PA21 | PA21MD | — | — | √ | — |

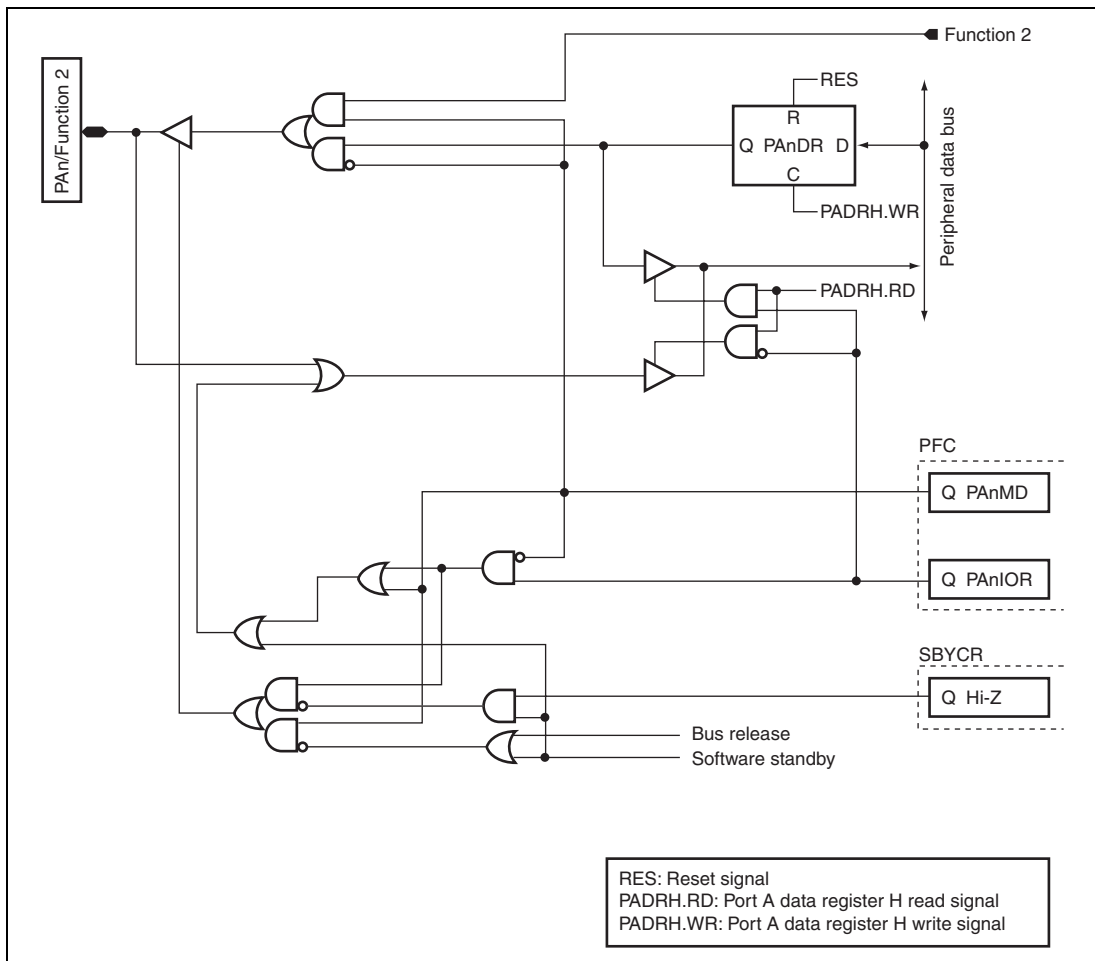

Figure D.13 PA n/Function 2

Symbol in Figure D.13

Available Products

| Pins | PA n | Function 2 | Available Products | | | |
|-------------------------|------|-------------------------|--------------------|---|----------------|---|
| | | | SH7144 | | SH7145 | |
| | | | F-ZTAT version | Masked ROM version/ ROM less version | F-ZTAT version | Masked ROM version/ ROM less version |
| PA20/ $\overline{CS4}$ | PA20 | $\overline{CS4}$ (BSC) | — | — | — | √ |
| PA21/ $\overline{CS5}$ | PA21 | $\overline{CS5}$ (BSC) | — | — | — | √ |
| PA22/ \overline{WRHL} | PA22 | \overline{WRHL} (BSC) | — | — | √ | √ |
| PA23/ \overline{WRHH} | PA23 | \overline{WRHH} (BSC) | — | — | √ | √ |

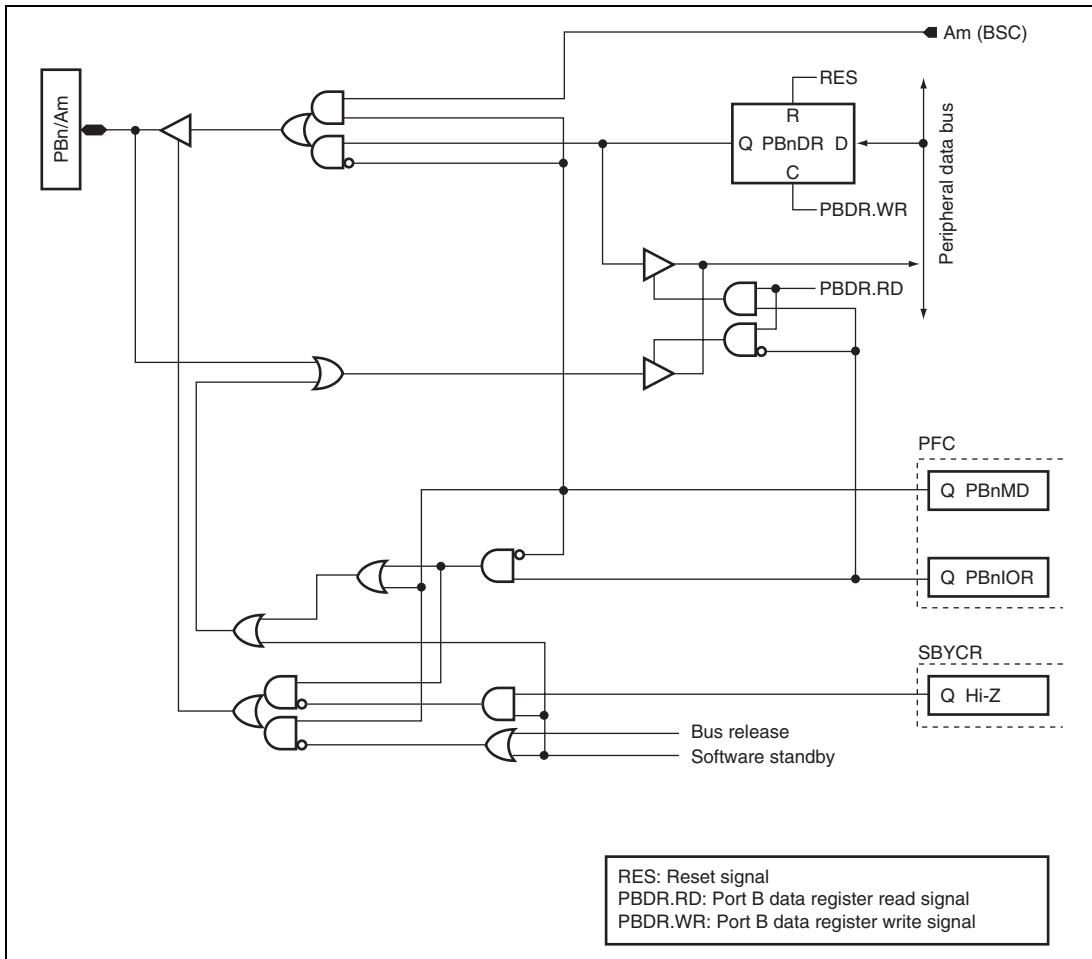
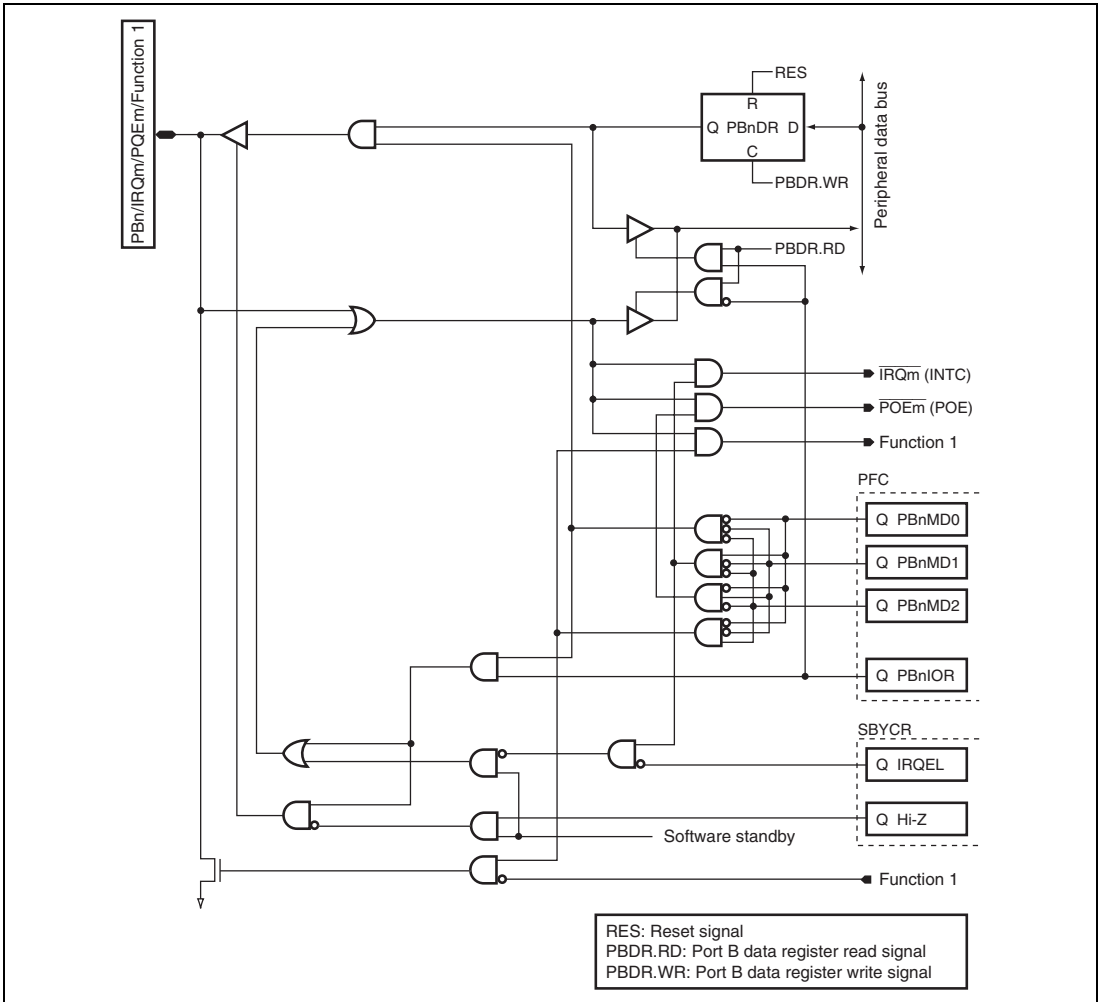

Figure D.14 PBn/Am

Symbol in Figure D.14

Available Products

| Pins | PBn | Am | Available Products | | | |
|---------|-----|-----------|--------------------|---|--------------------------|---|
| | | | F-ZTAT version | SH7144 Masked ROM version/ ROM less version | SH7145 F-ZTAT version | SH7145 Masked ROM version/ ROM less version |
| PB0/A16 | PB0 | A16 (BSC) | √ | √ | √ | √ |
| PB1/A17 | PB1 | A17 (BSC) | √ | √ | √ | √ |

Figure D.15 $\overline{\text{PBn}}/\overline{\text{IRQm}}/\overline{\text{POEm}}/\text{Function 1}$

Symbol in Figure D.15

Available Products

| Pins | PBn | $\overline{\text{IRQm}}$ | $\overline{\text{POEm}}$ | Function 1 | Available Products | | | |
|---|-----|------------------------------------|-----------------------------------|------------|--------------------|---|---|----------------|
| | | | | | F-ZTAT version | SH7144 Masked ROM version/ ROM less version | SH7145 Masked ROM version/ ROM less version | F-ZTAT version |
| PB2/ $\overline{\text{IRQ0}}$ / $\overline{\text{POE0}}/\text{SCL0}$ | PB2 | $\overline{\text{IRQ0}}$ (INTC) | $\overline{\text{POE0}}$ (POE) | SCL0 (IIC) | √ | √ | √ | √ |
| PB3/ $\overline{\text{IRQ1}}$ / $\overline{\text{POE1}}/\text{SDA0}$ | PB3 | $\overline{\text{IRQ1}}$ (INTC) | $\overline{\text{POE1}}$ (POE) | SDA0 (IIC) | √ | √ | √ | √ |

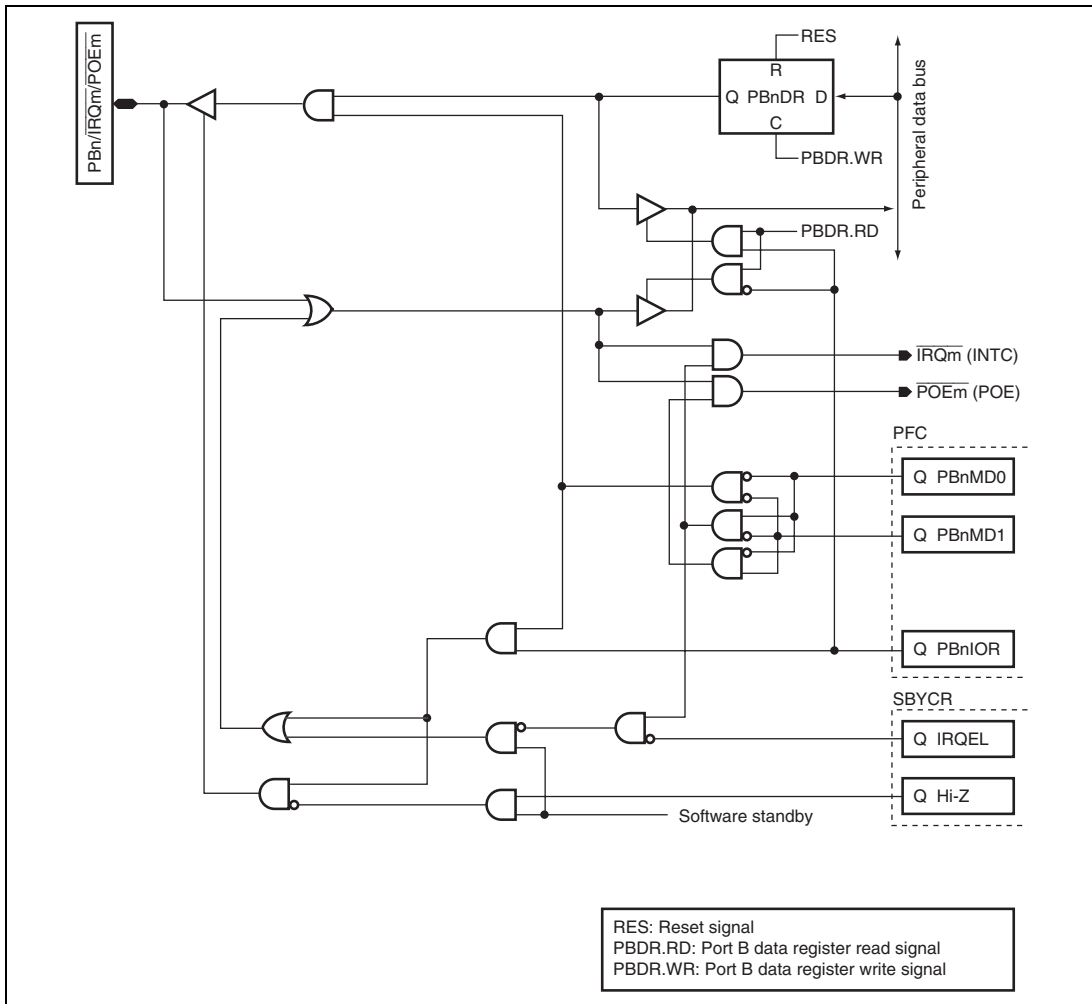
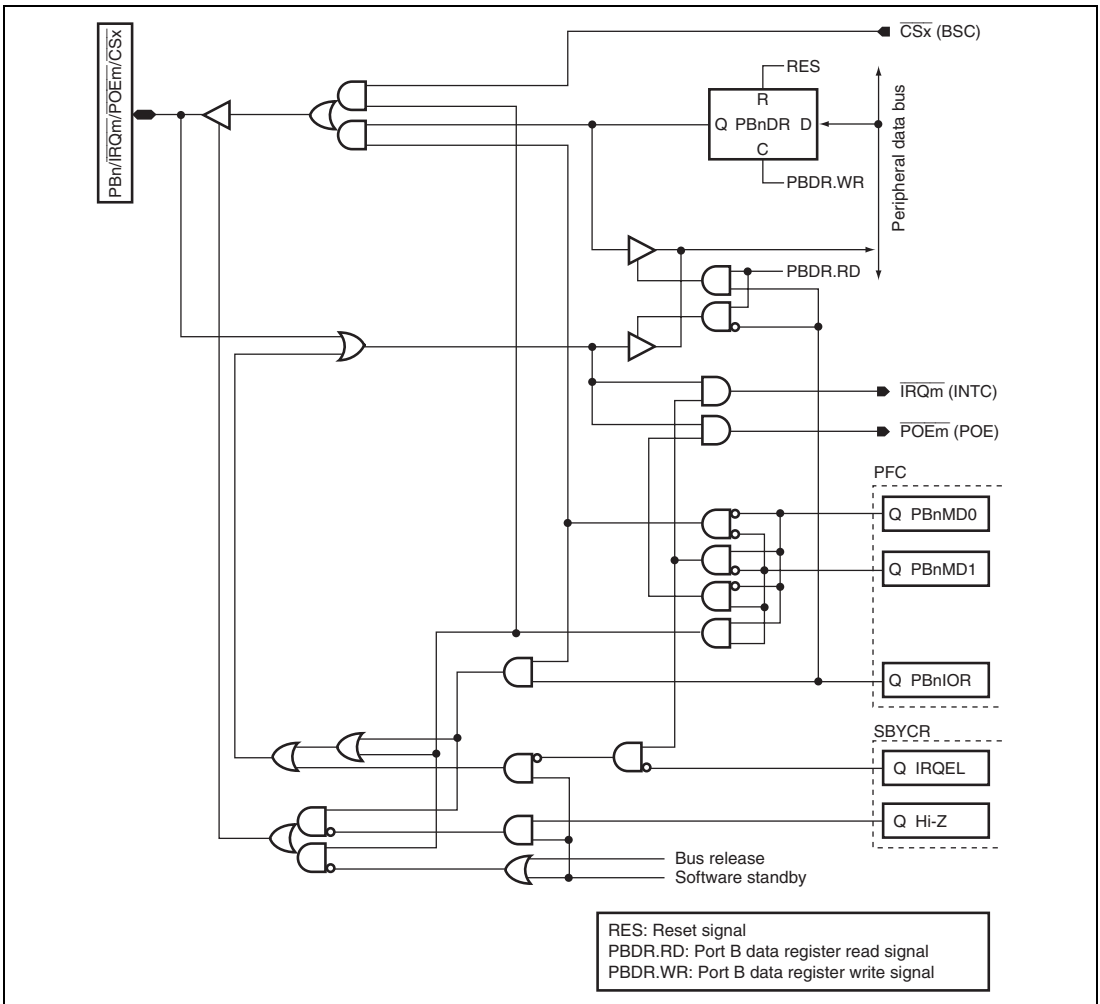

Figure D.16 PBn/IRQm/POEm

Symbol in Figure D.16

Available Products

| Pins | PBn | IRQm | POEm | F-ZTAT version | SH7144 | | SH7145 | |
|-------------------|-----|----------------|---------------|----------------|---|----------------|---|----------------|
| | | | | | Masked ROM version/ ROM less version | F-ZTAT version | Masked ROM version/ ROM less version | F-ZTAT version |
| PB4/IRQ2/ POE2 | PB4 | IRQ2 (INTC) | POE2 (POE) | √ | — | √ | — | |
| PB5/IRQ3/ POE3 | PB5 | IRQ3 (INTC) | POE3 (POE) | √ | — | √ | — | |

Figure D.17 $\overline{PBn}/\overline{IRQm}/\overline{POEm}/\overline{CSx}$

Symbol in Figure D.17

Available Products

| Pins | PBn | \overline{IRQm} | \overline{POEm} | \overline{CSx} | F-ZTAT version | SH7144 | | SH7145 | |
|-----------------------|-----|-------------------|-------------------|------------------|----------------|---|----------------|---|----------------|
| | | | | | | Masked ROM version/ ROM less version | F-ZTAT version | Masked ROM version/ ROM less version | F-ZTAT version |
| PB4/IRQ2/ POE2/CS6 | PB4 | IRQ2 (INTC) | POE2 (POE) | CS6 (BSC) | — | √ | — | √ | √ |
| PB5/IRQ3/ POE3/CS7 | PB5 | IRQ3 (INTC) | POE3 (POE) | CS7 (BSC) | — | √ | — | √ | √ |

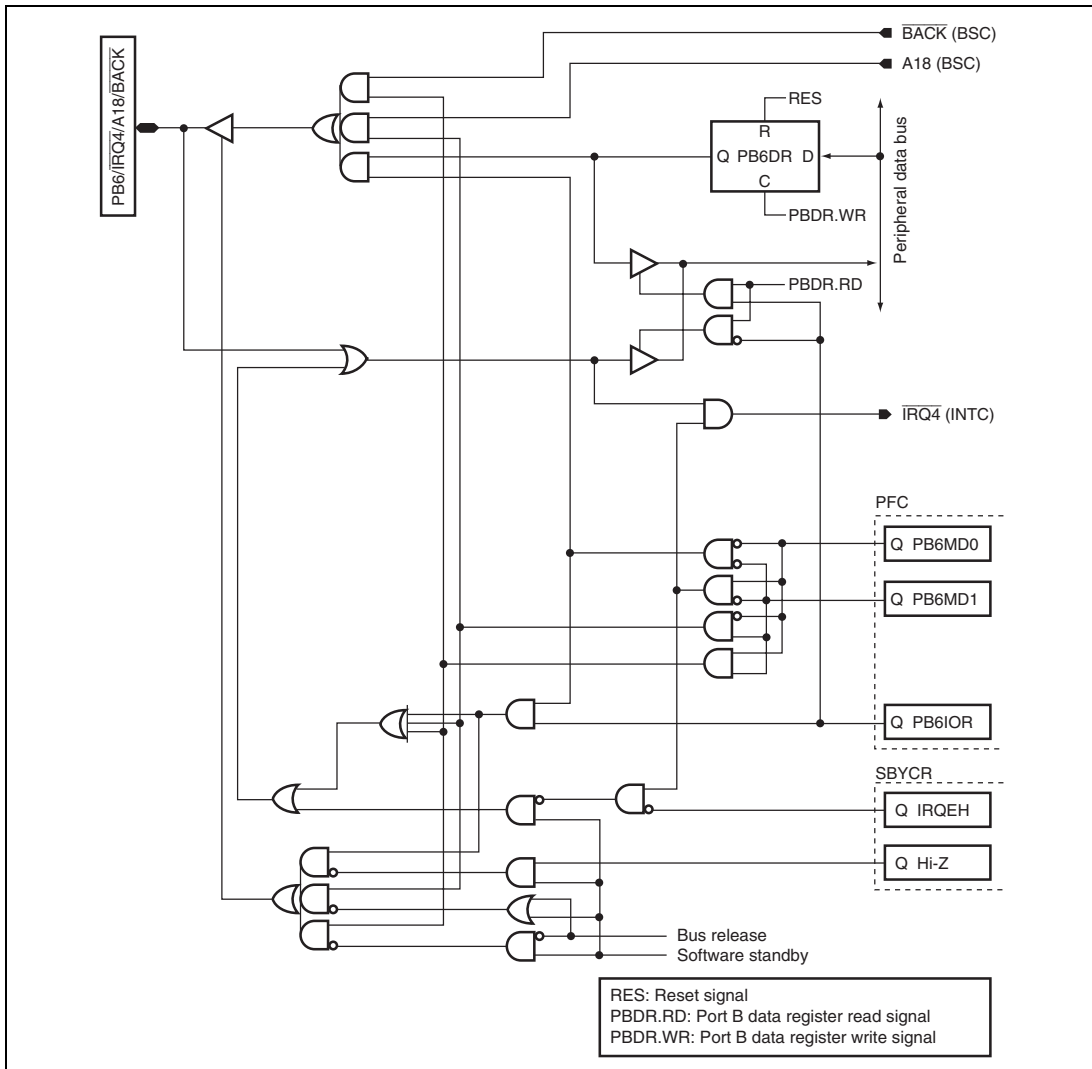

Figure D.18 $\overline{\text{PB6}}/\overline{\text{IRQ4}}/\text{A18}/\overline{\text{BACK}}$

Symbol in Figure D.18

Available Products

| Pins | PB6 | $\overline{\text{IRQ4}}$ | A18 | $\overline{\text{BACK}}$ | F-ZTAT version | Available Products | |
|--|-----|------------------------------------|--------------|-----------------------------------|-------------------|---|---|
| | | | | | | SH7144 | SH7145 |
| | | | | | | Masked ROM version/ ROM less version | Masked ROM version/ ROM less version |
| $\overline{\text{PB6}}/\overline{\text{IRQ4}}/\text{A18}/\overline{\text{BACK}}$ | PB6 | $\overline{\text{IRQ4}}$ (INTC) | A18 (BSC) | $\overline{\text{BACK}}$ (BSC) | ✓ | ✓ | ✓ |

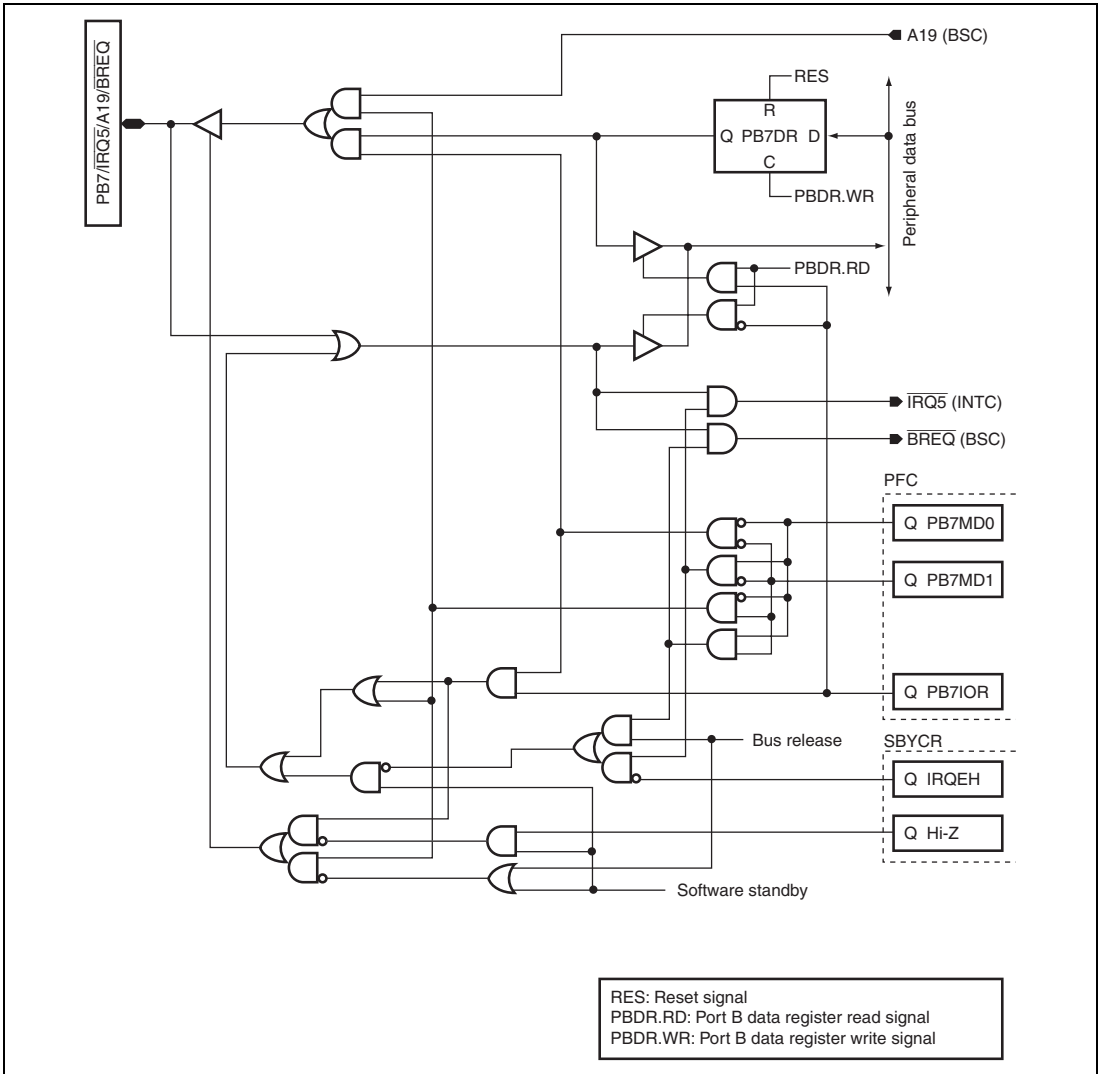

Figure D.19 $\overline{PB7}/\overline{IRQ5}/A19/\overline{BREQ}$

| Symbol in Figure D.19 | | Available Products | | | | | | |
|--|------------------|-----------------------------|--------------|----------------------------|----------------|---|----------------|---|
| | | SH7144 | | SH7145 | | | | |
| Pins | $\overline{PB7}$ | $\overline{IRQ5}$ | A19 | \overline{BREQ} | F-ZTAT version | Masked ROM version/ ROM less version | F-ZTAT version | Masked ROM version/ ROM less version |
| $\overline{PB7}/\overline{IRQ5}/A19/\overline{BREQ}$ | $\overline{PB7}$ | $\overline{IRQ5}$ (INTC) | A19 (BSC) | \overline{BREQ} (BSC) | ✓ | ✓ | ✓ | ✓ |

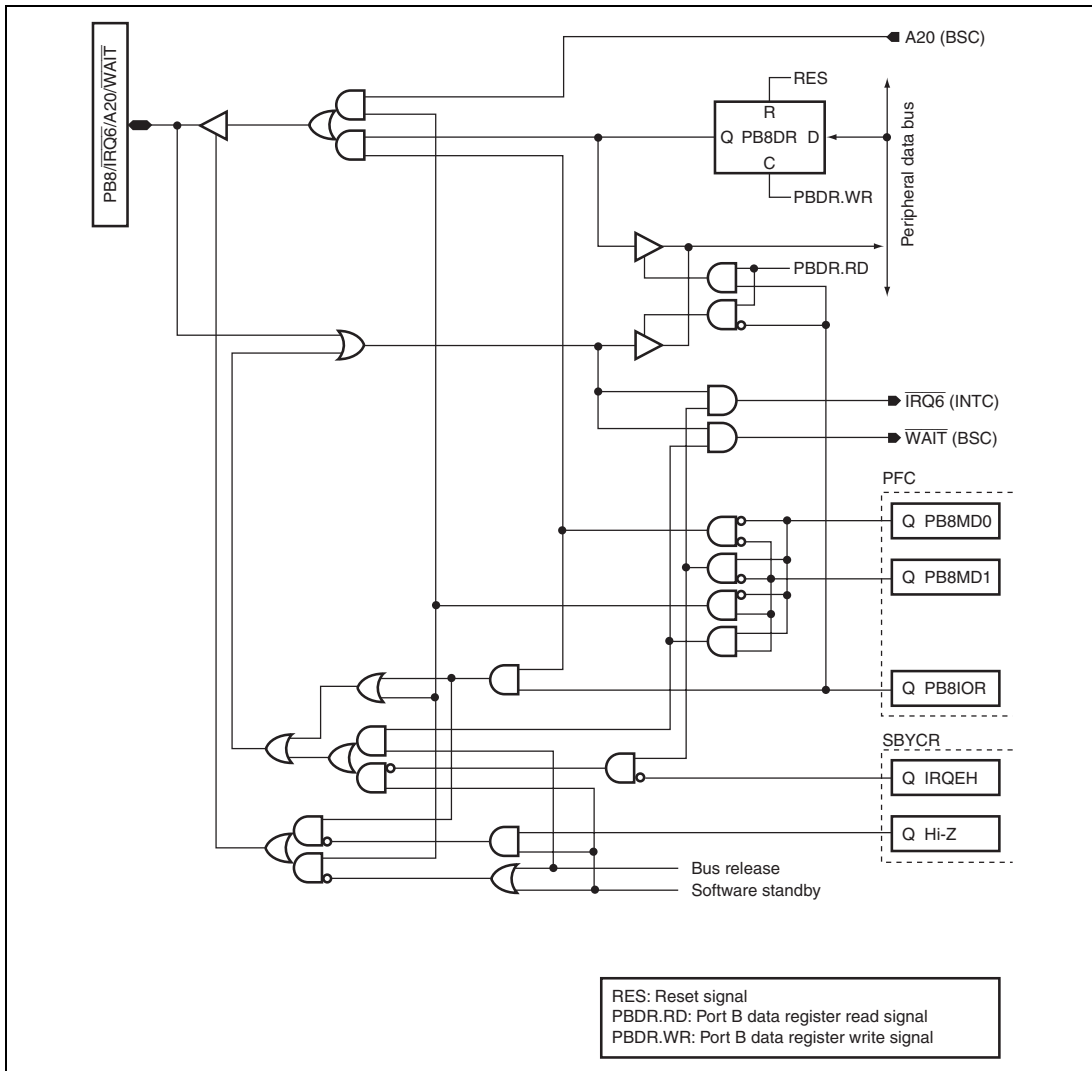

Figure D.20 $\overline{PB8}/\overline{IRQ6}/A20/\overline{WAIT}$

| Symbol in Figure D.20 | | Available Products | | | | | | |
|--|-----|-----------------------------|--------------|----------------------------|----------------|---|----------------|---|
| | | SH7144 | | | SH7145 | | | |
| Pins | PB8 | $\overline{IRQ6}$ | A20 | \overline{WAIT} | F-ZTAT version | Masked ROM version/ ROM less version | F-ZTAT version | Masked ROM version/ ROM less version |
| $\overline{PB8}/\overline{IRQ6}/A20/\overline{WAIT}$ | PB8 | $\overline{IRQ6}$ (INTC) | A20 (BSC) | \overline{WAIT} (BSC) | ✓ | ✓ | ✓ | ✓ |

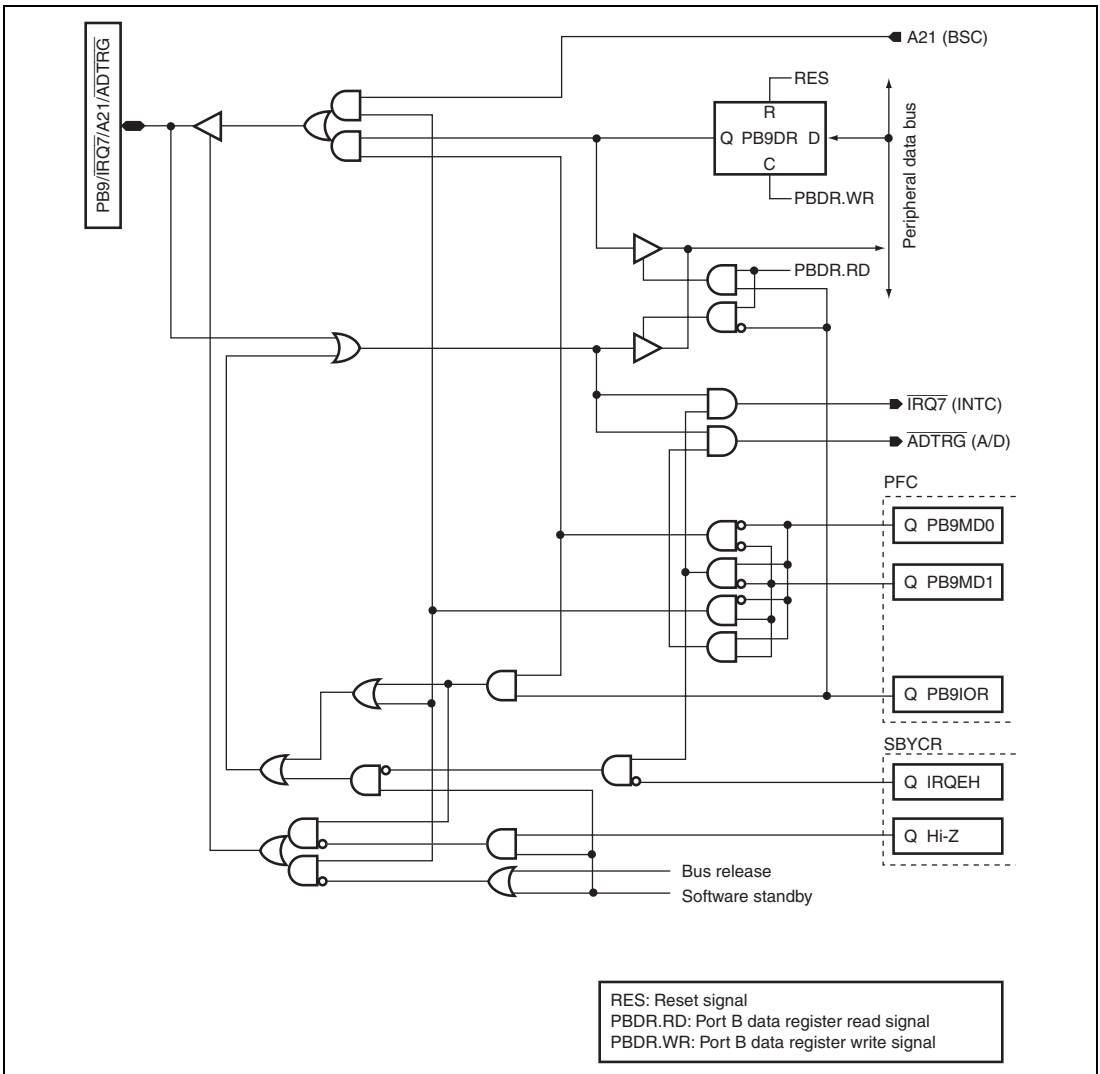

Figure D.21 PB9/IRQ7/A21/ADTRG

Symbol in Figure D.21

Available Products

| Pins | Symbol in Figure D.21 | | | | Available Products | | | |
|------------------------|-----------------------|----------------|--------------|----------------|--------------------|---|----------------|---|
| | PB9 | IRQ7 | A21 | ADTRG | F-ZTAT version | SH7144 Masked ROM version/ ROM less version | F-ZTAT version | SH7145 Masked ROM version/ ROM less version |
| PB9/IRQ7/ A21/ADTRG | PB9 | IRQ7 (INTC) | A21 (BSC) | ADTRG (A/D) | √ | √ | √ | √ |

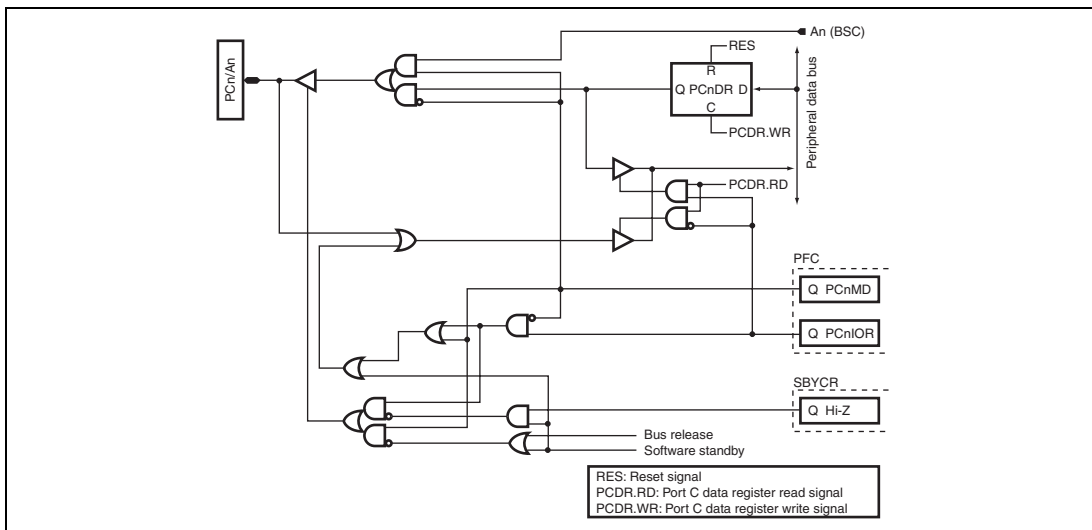

Figure D.22 PCn/An

Symbol in Figure D.22

Available Products

| Pins | PCn | An | Available Products | | | |
|----------|------|-----------|--------------------|---|----------------|---|
| | | | SH7144 | | SH7145 | |
| | | | F-ZTAT version | Masked ROM version/ ROM less version | F-ZTAT version | Masked ROM version/ ROM less version |
| PC0/A0 | PC0 | A0 (BSC) | √ | √ | √ | √ |
| PC1/A1 | PC1 | A1 (BSC) | √ | √ | √ | √ |
| PC2/A2 | PC2 | A2 (BSC) | √ | √ | √ | √ |
| PC3/A3 | PC3 | A3 (BSC) | √ | √ | √ | √ |
| PC4/A4 | PC4 | A4 (BSC) | √ | √ | √ | √ |
| PC5/A5 | PC5 | A5 (BSC) | √ | √ | √ | √ |
| PC6/A6 | PC6 | A6 (BSC) | √ | √ | √ | √ |
| PC7/A7 | PC7 | A7 (BSC) | √ | √ | √ | √ |
| PC8/A8 | PC8 | A8 (BSC) | √ | √ | √ | √ |
| PC9/A9 | PC9 | A9 (BSC) | √ | √ | √ | √ |
| PC10/A10 | PC10 | A10 (BSC) | √ | √ | √ | √ |
| PC11/A11 | PC11 | A11 (BSC) | √ | √ | √ | √ |
| PC12/A12 | PC12 | A12 (BSC) | √ | √ | √ | √ |
| PC13/A13 | PC13 | A13 (BSC) | √ | √ | √ | √ |
| PC14/A14 | PC14 | A14 (BSC) | √ | √ | √ | √ |
| PC15/A15 | PC15 | A15 (BSC) | √ | √ | √ | √ |

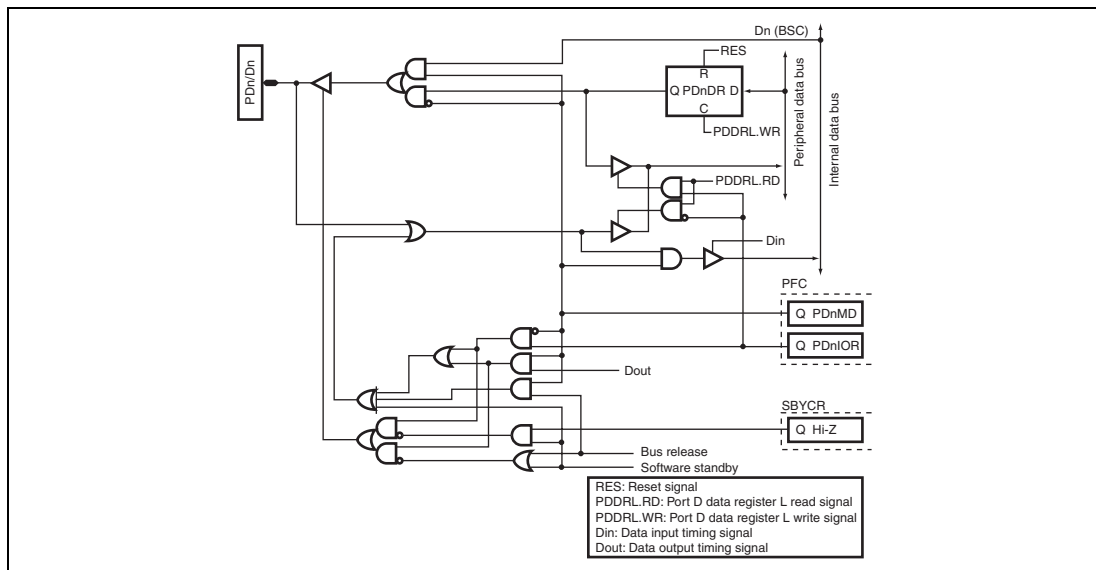

Figure D.23 PDn/Dn

Symbol in Figure D.23

Available Products

| Pins | PDn | Dn | PDnMD | Available Products | | | |
|----------|------|-----------|---------|--------------------|--|----------------|--|
| | | | | F-ZTAT version | SH7144 Masked ROM version/ ROM less version | F-ZTAT version | SH7145 Masked ROM version/ ROM less version |
| PD0/D0 | PD0 | D0 (BSC) | PD0MD | √ | √ | √ | √ |
| PD1/D1 | PD1 | D1 (BSC) | PD1MD | √ | √ | √ | √ |
| PD2/D2 | PD2 | D2 (BSC) | PD2MD | √ | √ | √ | √ |
| PD3/D3 | PD3 | D3 (BSC) | PD3MD | √ | √ | √ | √ |
| PD4/D4 | PD4 | D4 (BSC) | PD4MD | √ | √ | √ | √ |
| PD5/D5 | PD5 | D5 (BSC) | PD5MD | √ | √ | √ | √ |
| PD6/D6 | PD6 | D6 (BSC) | PD6MD | √ | √ | √ | √ |
| PD7/D7 | PD7 | D7 (BSC) | PD7MD | √ | √ | √ | √ |
| PD8/D8 | PD8 | D8 (BSC) | PD8MD0 | — | √ | √ | √ |
| PD9/D9 | PD9 | D9 (BSC) | PD9MD0 | — | √ | √ | √ |
| PD10/D10 | PD10 | D10 (BSC) | PD10MD0 | — | √ | √ | √ |
| PD11/D11 | PD11 | D11 (BSC) | PD11MD0 | — | √ | √ | √ |
| PD12/D12 | PD12 | D12 (BSC) | PD12MD0 | — | √ | √ | √ |
| PD13/D13 | PD13 | D13 (BSC) | PD13MD0 | — | √ | √ | √ |
| PD14/D14 | PD14 | D14 (BSC) | PD14MD0 | — | √ | √ | √ |
| PD15/D15 | PD15 | D15 (BSC) | PD15MD0 | — | √ | √ | √ |

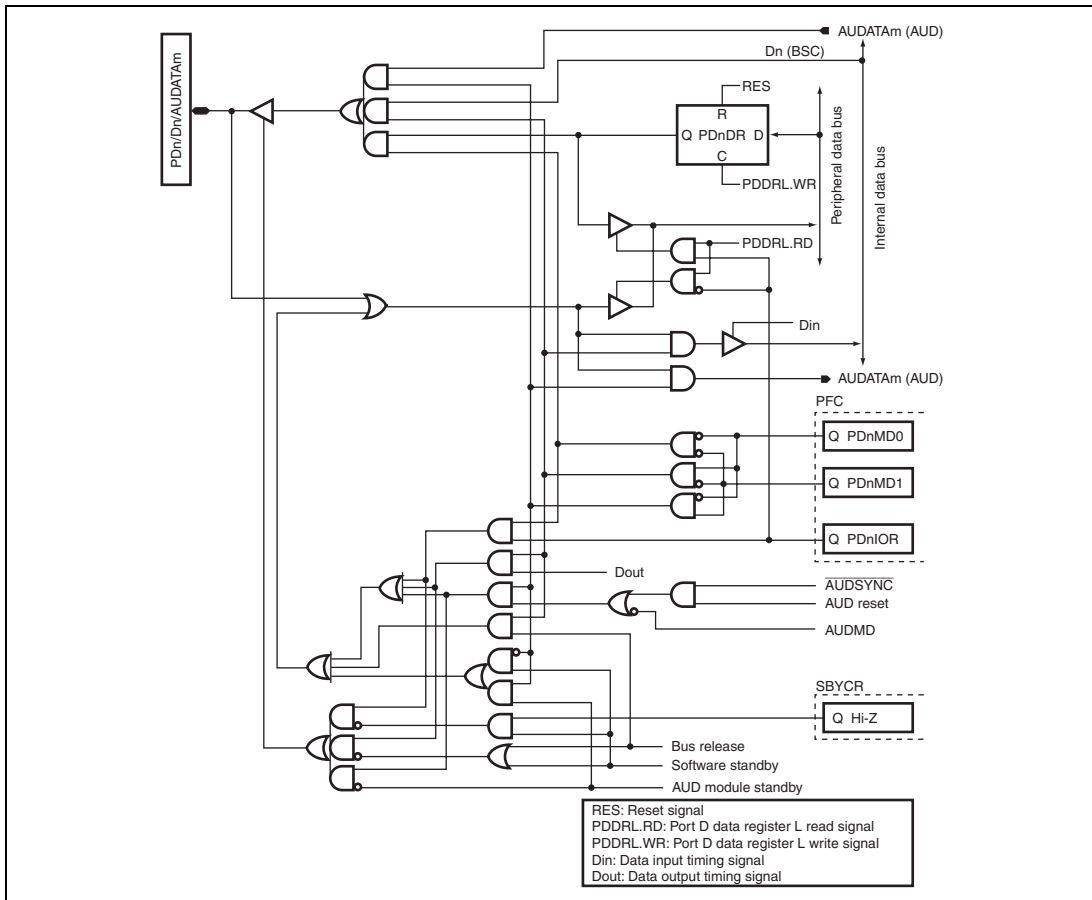

Figure D.24 PDn/Dn/AUDATAm

Symbol in Figure D.24

Available Products

| Pins | PDn | Dn | AUDATAm | F-ZTAT version | Available Products | | |
|----------------------|------|--------------|------------------|----------------|---|----------------|---|
| | | | | | SH7144 | F-ZTAT version | SH7145 |
| PD8/D8/ AUDATA0 | PD8 | D8 (BSC) | AUDATA0 (AUD) | √ | Masked ROM version/ ROM less version | — | Masked ROM version/ ROM less version |
| PD9/D9/ AUDATA1 | PD9 | D9 (BSC) | AUDATA1 (AUD) | √ | — | — | — |
| PD10/D10/ AUDATA2 | PD10 | D10 (BSC) | AUDATA2 (AUD) | √ | — | — | — |
| PD11/D11/ AUDATA3 | PD11 | D11 (BSC) | AUDATA3 (AUD) | √ | — | — | — |

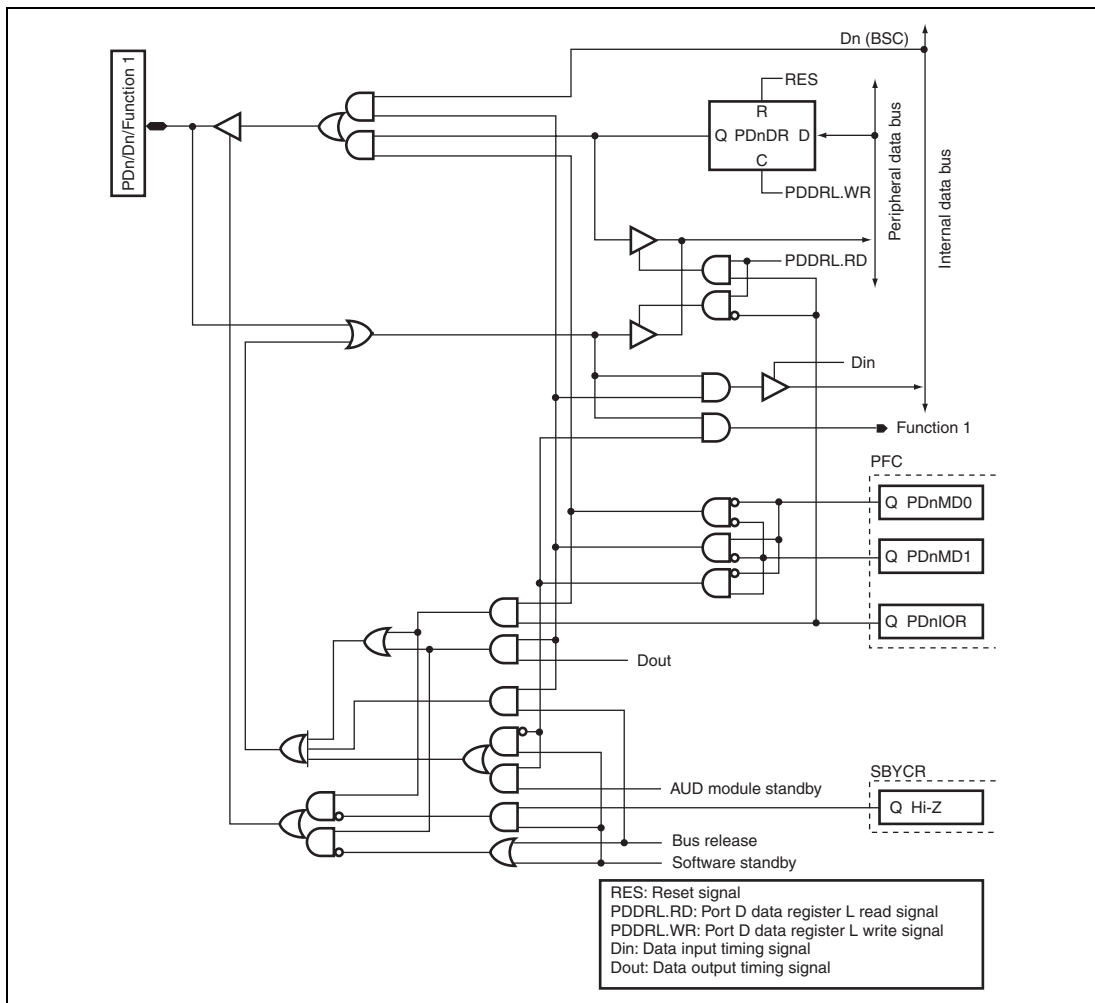

Figure D.25 PDn/Dn/Function 1

Symbol in Figure D.25

Available Products

| Pins | PDn | Dn | Function 1 | Available Products | | | |
|---------------------|------|--------------|-----------------|--------------------|---|--------------------------|---|
| | | | | F-ZTAT version | SH7144 Masked ROM version/ ROM less version | SH7145 F-ZTAT version | SH7145 Masked ROM version/ ROM less version |
| PD12/D12/ AUDRST | PD12 | D12 (BSC) | AUDRST (AUD) | √ | — | — | — |
| PD13/D13 /AUDMD | PD13 | D13 (BSC) | AUDMD (AUD) | √ | — | — | — |

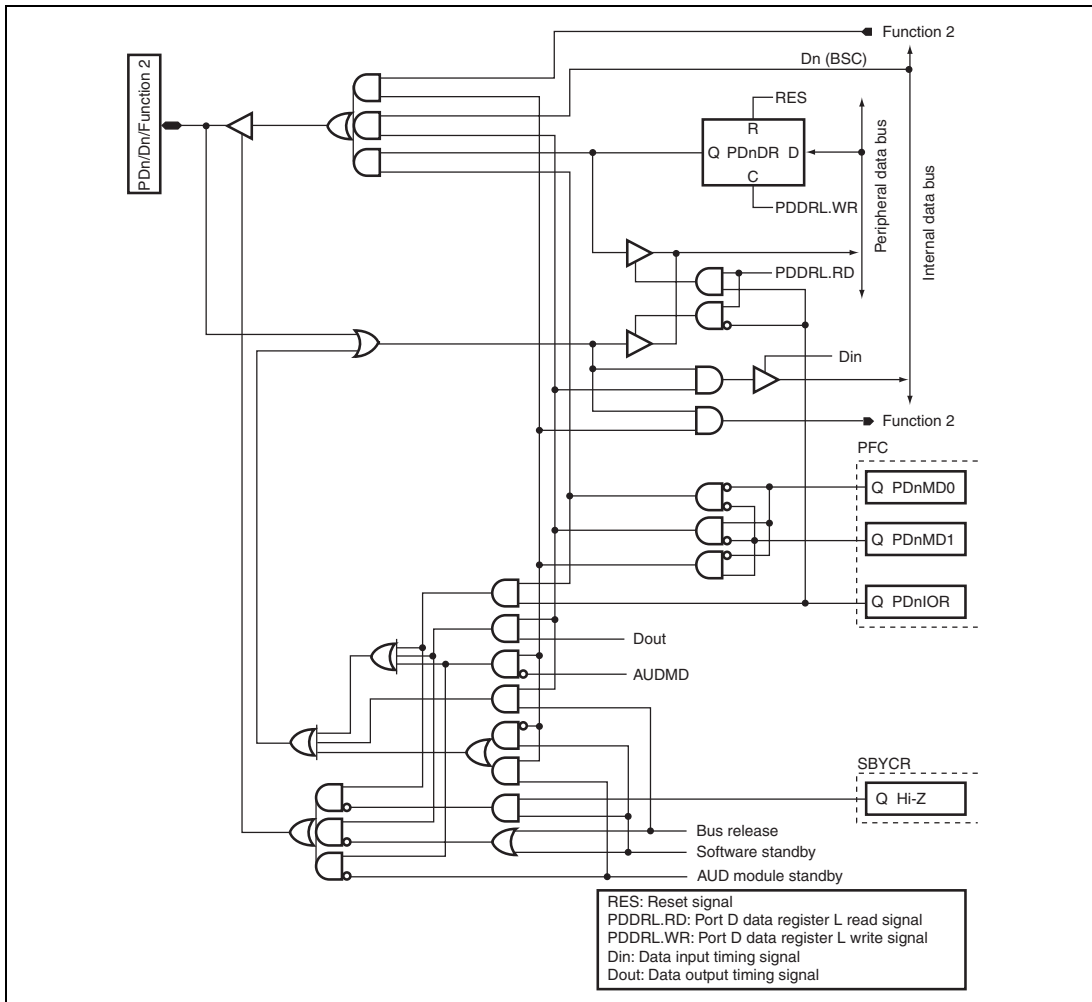
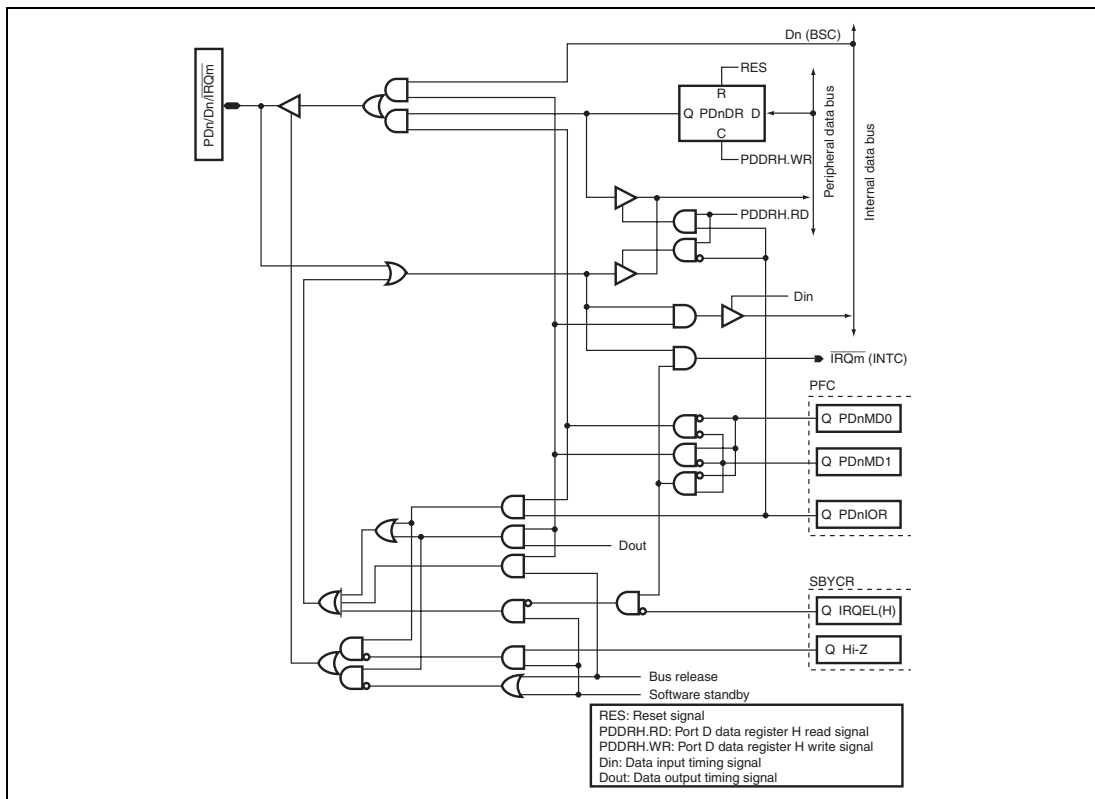

Figure D.26 PDn/Dn/Function 2

Symbol in Figure D.26

Available Products

| Pins | PDn | Dn | Function 2 | Available Products | | | |
|----------------------|------|--------------|-------------------|--------------------|---|----------------|---|
| | | | | F-ZTAT version | SH7144 Masked ROM version/ ROM less version | F-ZTAT version | SH7145 Masked ROM version/ ROM less version |
| PD14/D14/ AUDCK | PD14 | D14 (BSC) | AUDCK (AUD) | ✓ | — | — | — |
| PD15/D15/ AUDSYNC | PD15 | D15 (BSC) | AUDSYN C (AUD) | ✓ | — | — | — |

Figure D.27 PDn/Dn/ $\overline{\text{IRQ}}_m$

Symbol in Figure D.27

Available Products

| Pins | PDn | Dn | $\overline{\text{IRQ}}_m$ | Available Products | | | |
|-------------------------------------|------|-----------|----------------------------------|--------------------|---|----------------|---|
| | | | | F-ZTAT version | SH7144 Masked ROM version/ ROM less version | F-ZTAT version | SH7145 Masked ROM version/ ROM less version |
| PD16/D16/ $\overline{\text{IRQ}}_0$ | PD16 | D16 (BSC) | $\overline{\text{IRQ}}_0$ (INTC) | — | — | — | √ |
| PD17/D17/ $\overline{\text{IRQ}}_1$ | PD17 | D17 (BSC) | $\overline{\text{IRQ}}_1$ (INTC) | — | — | — | √ |
| PD18/D18/ $\overline{\text{IRQ}}_2$ | PD18 | D18 (BSC) | $\overline{\text{IRQ}}_2$ (INTC) | — | — | — | √ |
| PD19/D19/ $\overline{\text{IRQ}}_3$ | PD19 | D19 (BSC) | $\overline{\text{IRQ}}_3$ (INTC) | — | — | — | √ |
| PD20/D20/ $\overline{\text{IRQ}}_4$ | PD20 | D20 (BSC) | $\overline{\text{IRQ}}_4$ (INTC) | — | — | — | √ |
| PD21/D21/ $\overline{\text{IRQ}}_5$ | PD21 | D21 (BSC) | $\overline{\text{IRQ}}_5$ (INTC) | — | — | — | √ |
| PD22/D22/ $\overline{\text{IRQ}}_6$ | PD22 | D22 (BSC) | $\overline{\text{IRQ}}_6$ (INTC) | — | — | — | √ |
| PD23/D23/ $\overline{\text{IRQ}}_7$ | PD23 | D23 (BSC) | $\overline{\text{IRQ}}_7$ (INTC) | — | — | — | √ |

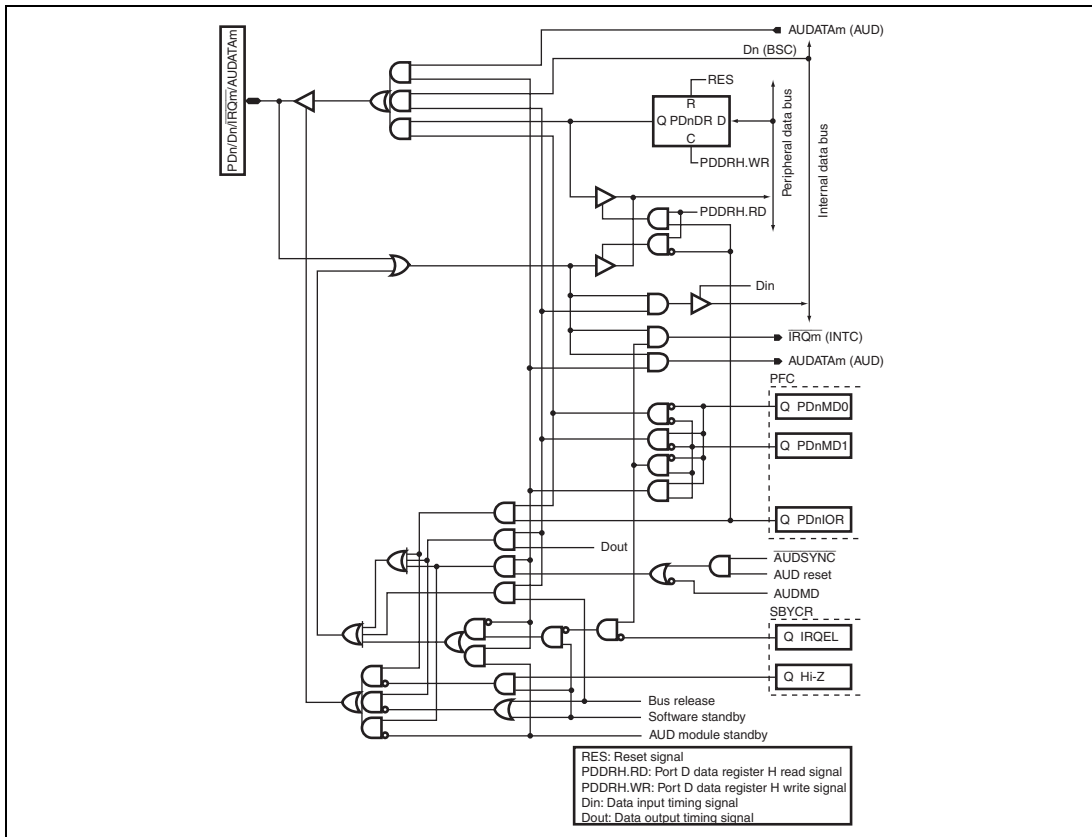

Figure D.28 PDn/Dn/IRQm/AUDATAm

Symbol in Figure D.28

Available Products

| Pins | PDn | Dn | IRQm | AUDATAm | Available Products | | | |
|-------------------------------|------|--------------|----------------|------------------|---|----------------|---|---|
| | | | | | SH7144 | | SH7145 | |
| | | | | F-ZTAT version | Masked ROM version/ ROM less version | F-ZTAT version | Masked ROM version/ ROM less version | |
| PD16/D16/ IRQ0/ AUDATA0 | PD16 | D16 (BSC) | IRQ0 (INTC) | AUDATA0 (AUD) | — | — | √ | — |
| PD17/D17/ IRQ1/ AUDATA1 | PD17 | D17 (BSC) | IRQ1 (INTC) | AUDATA1 (AUD) | — | — | √ | — |
| PD18/D18/ IRQ2/ AUDATA2 | PD18 | D18 (BSC) | IRQ2 (INTC) | AUDATA2 (AUD) | — | — | √ | — |
| PD19/D19/ IRQ3/ AUDATA3 | PD19 | D19 (BSC) | IRQ3 (INTC) | AUDATA3 (AUD) | — | — | √ | — |

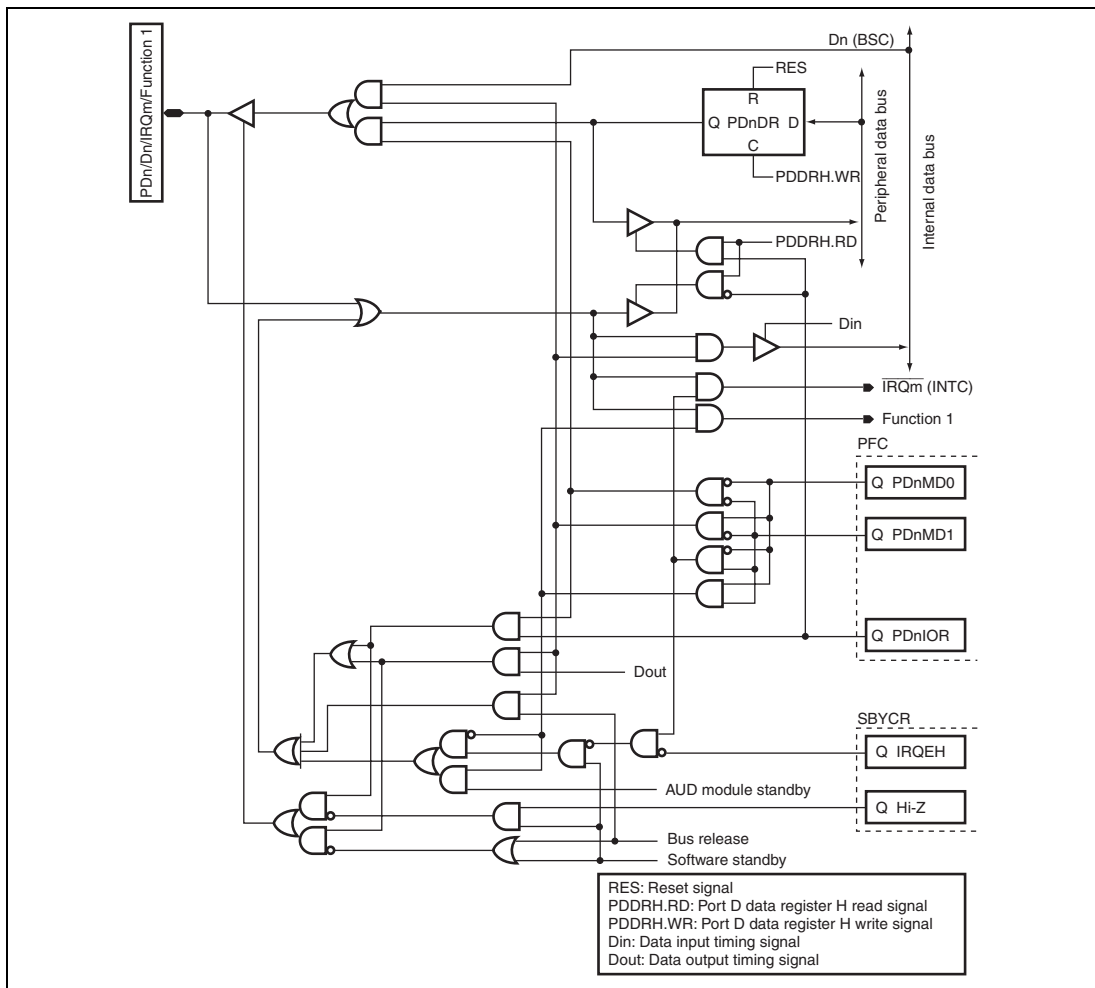

Figure D.29 PDn/Dn/ $\overline{\text{IRQm}}$ /Function 1

Symbol in Figure D.29

Available Products

| Pins | PDn | Dn | $\overline{\text{IRQm}}$ | Function 1 | Available Products | | | |
|---|------|--------------|------------------------------------|-----------------|--------------------|---|---|----------------|
| | | | | | F-ZTAT version | SH7144 Masked ROM version/ ROM less version | SH7145 Masked ROM version/ ROM less version | F-ZTAT version |
| PD20/D20/ $\overline{\text{IRQ4}}$ / AUDRST | PD20 | D20 (BSC) | $\overline{\text{IRQ4}}$ (INTC) | AUDRST (AUD) | — | — | √ | — |
| PD21/D21/ $\overline{\text{IRQ5}}$ / AUDMD | PD21 | D21 (BSC) | $\overline{\text{IRQ5}}$ (INTC) | AUDMD (AUD) | — | — | √ | — |

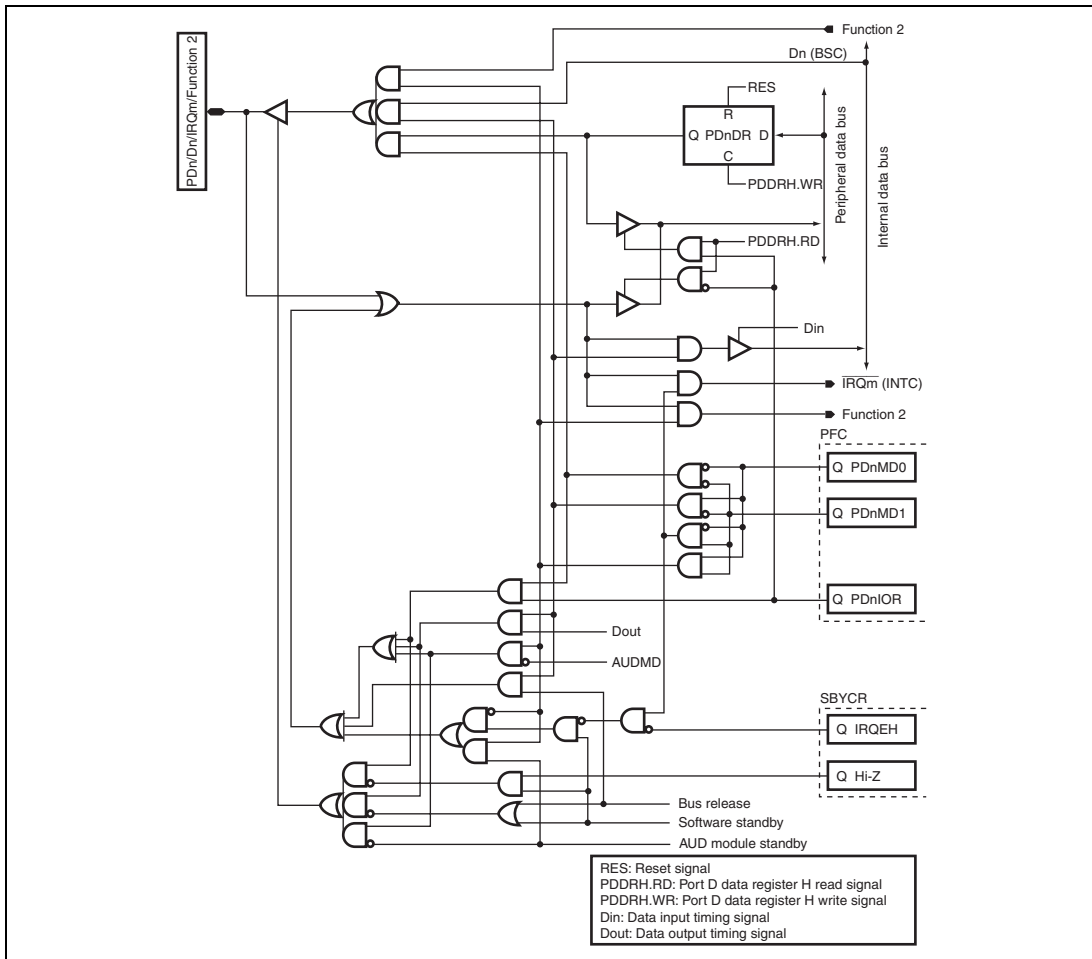

Figure D.30 PDn/Dn/ $\overline{\text{IRQm}}$ /Function 2

Symbol in Figure D.30

Available Products

| Pins | PDn | Dn | $\overline{\text{IRQm}}$ | Function 2 | F-ZTAT version | SH7144 | SH7145 |
|--|------|-----|-----------------------------------|--------------------------|----------------|---|---|
| | | | | | | Masked ROM version/ ROM less version | Masked ROM version/ ROM less version |
| PD22/D22/ $\overline{\text{IRQ6}}$ / AUDCK | PD22 | D22 | $\overline{\text{IRQ6}}$ (BSC) | AUDCK (INTC) (AUD) | — | — | √ |
| PD23/D23/ $\overline{\text{IRQ7}}$ / AUDSYNC | PD23 | D23 | $\overline{\text{IRQ7}}$ (BSC) | AUDSYN (INTC) C (AUD) | — | — | √ |

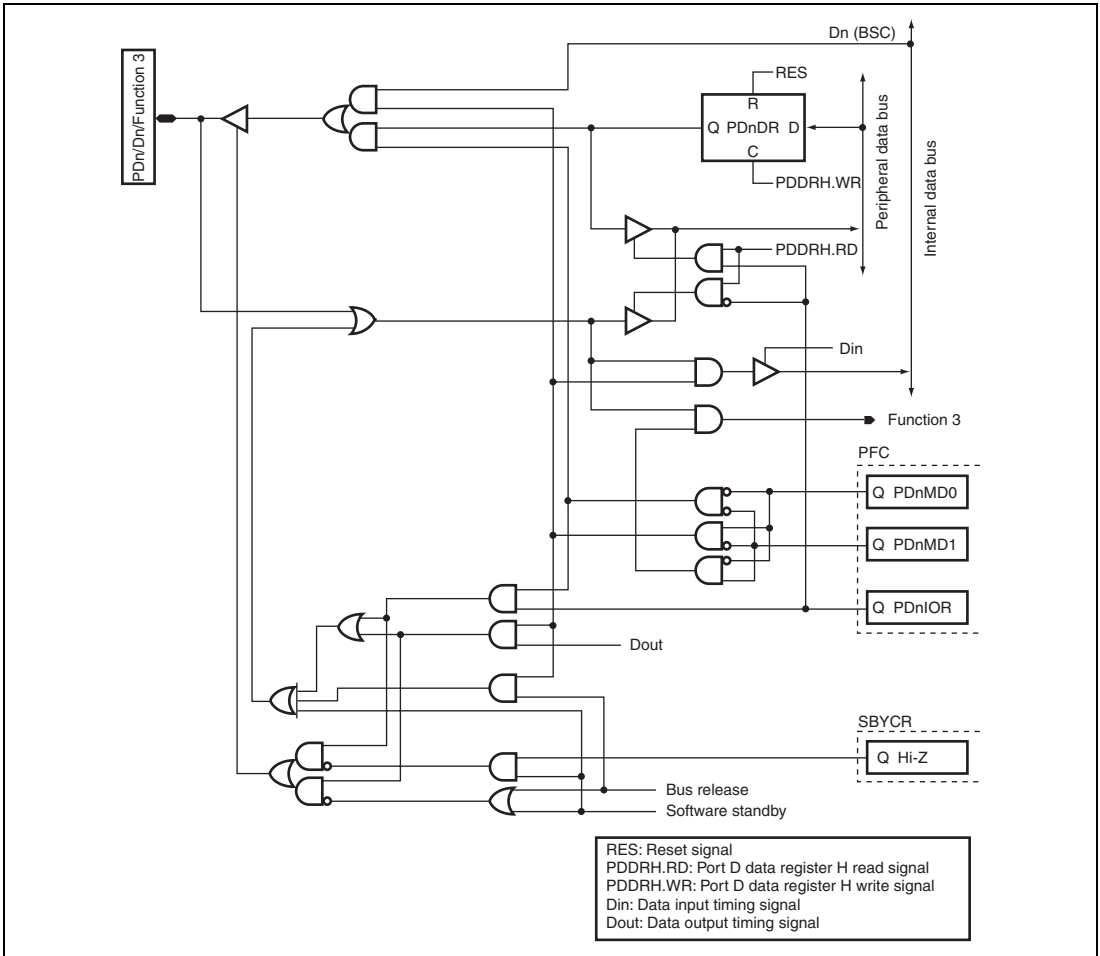

Figure D.31 PDn/Dn/Function 3

Symbol in Figure D.31

Available Products

| Pins | PDn | Dn | Function 3 | F-ZTAT version | Available Products | | |
|--------------------|------|--------------|-------------------------------------|----------------|---|----------------|---|
| | | | | | SH7144 | SH7145 | |
| | | | | | Masked ROM version/ ROM less version | F-ZTAT version | Masked ROM version/ ROM less version |
| PD24/D24/ DREQ0 | PD24 | D24 (BSC) | $\overline{\text{DREQ0}}$ (DMAC) | — | — | √ | √ |
| PD25/D25/ DREQ1 | PD25 | D25 (BSC) | $\overline{\text{DREQ1}}$ (DMAC) | — | — | √ | √ |
| PD31/D31/ ADTRG | PD31 | D31 (BSC) | ADTRG (A/D) | — | — | √ | √ |

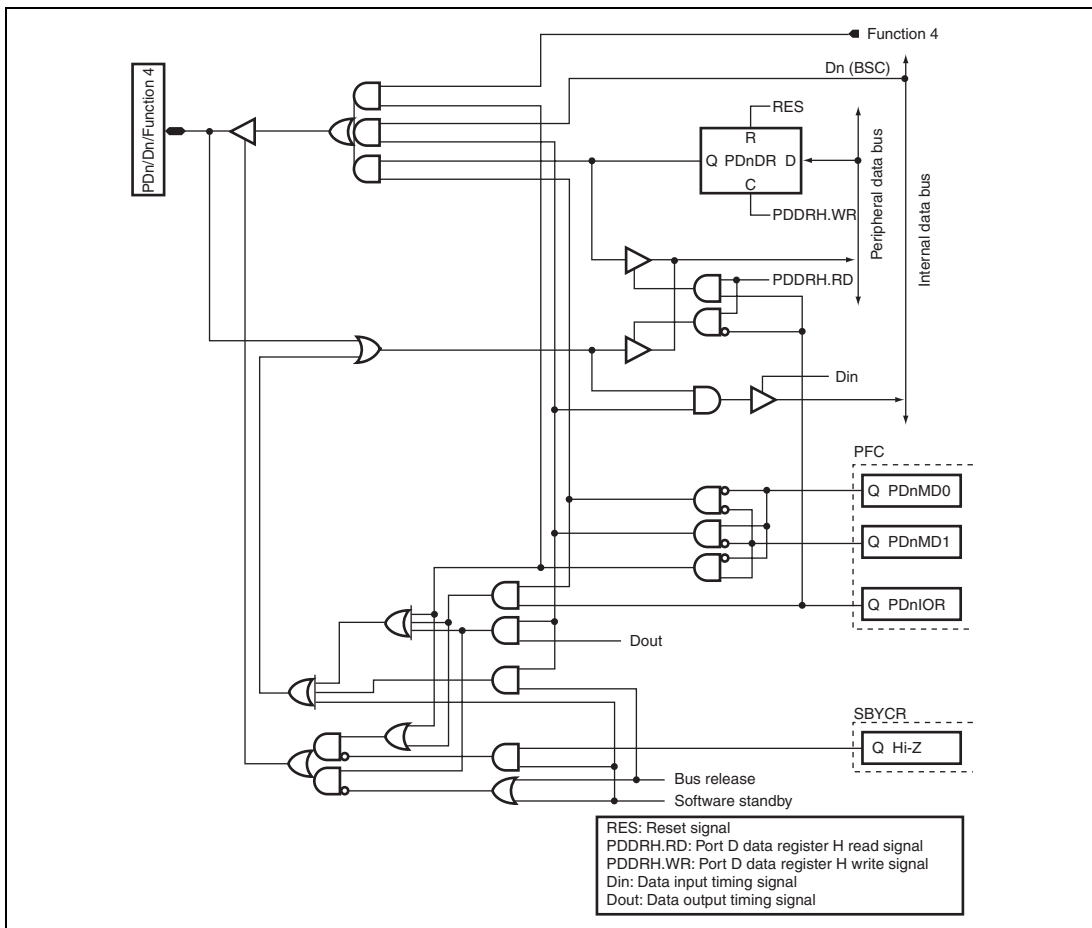

Figure D.32 PDn/Dn/Function 4

Symbol in Figure D.32

Available Products

| Pins | PDn | Dn | Function 4 | Available Products | | | |
|---------------------|------|--------------|------------------|--------------------|---|----------------|---|
| | | | | F-ZTAT version | SH7144 Masked ROM version/ ROM less version | F-ZTAT version | SH7145 Masked ROM version/ ROM less version |
| PD26/D26/ DACK0 | PD26 | D26 (BSC) | DACK0 (DMAC) | — | — | √ | √ |
| PD27/D27/ DACK1 | PD27 | D27 (BSC) | DACK1 (DMAC) | — | — | √ | √ |
| PD30/D30/ IRQOUT | PD30 | D30 (BSC) | IRQOUT (INTC) | — | — | √ | √ |

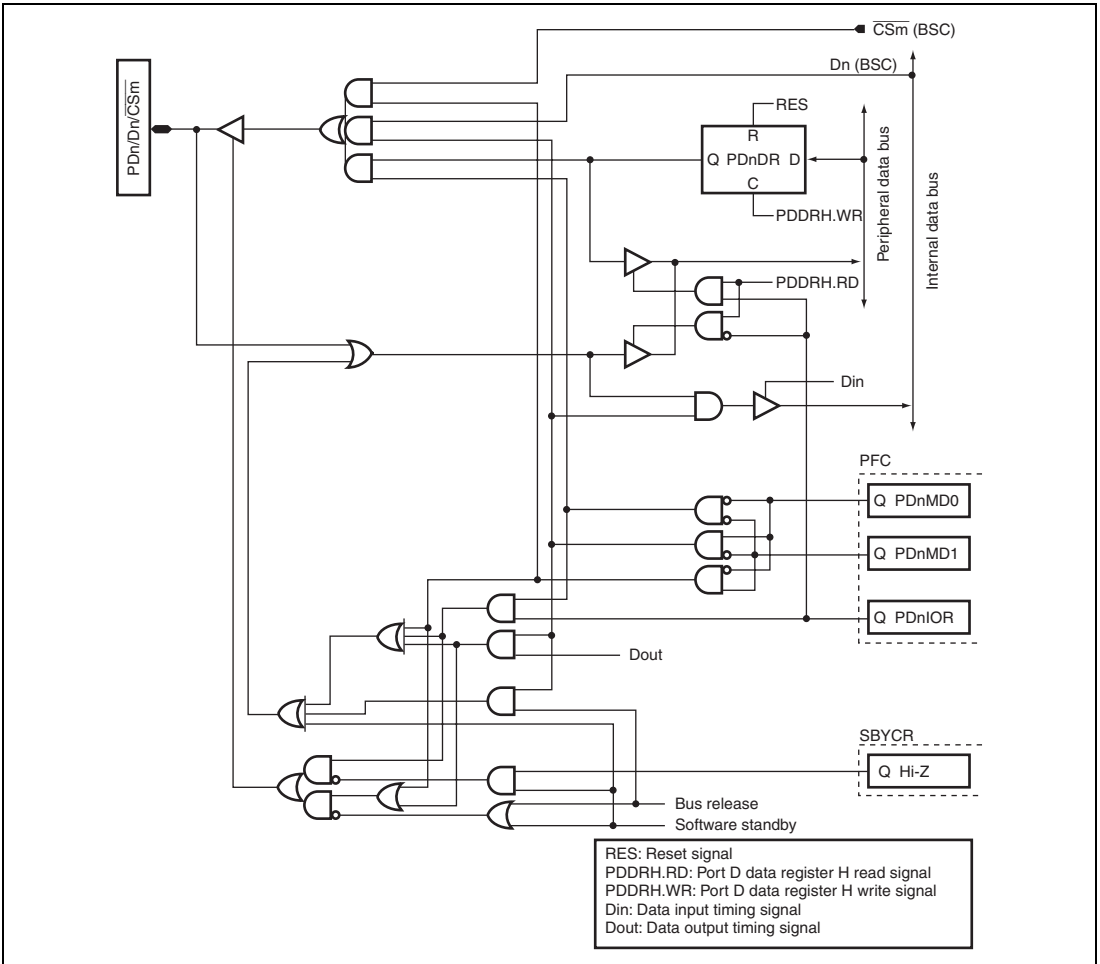

Figure D.33 PDn/Dn/ \overline{CSm}

Symbol in Figure D.33

Available Products

| Pins | PDn | Dn | \overline{CSm} | Available Products | | | |
|----------------------------|------|--------------|---------------------------|--------------------|---|----------------|---|
| | | | | F-ZTAT version | SH7144 Masked ROM version/ ROM less version | F-ZTAT version | SH7145 Masked ROM version/ ROM less version |
| PD28/D28/ $\overline{CS2}$ | PD28 | D28 (BSC) | $\overline{CS2}$ (BSC) | — | — | √ | √ |
| PD29/D29/ $\overline{CS3}$ | PD29 | D29 (BSC) | $\overline{CS3}$ (BSC) | — | — | √ | √ |

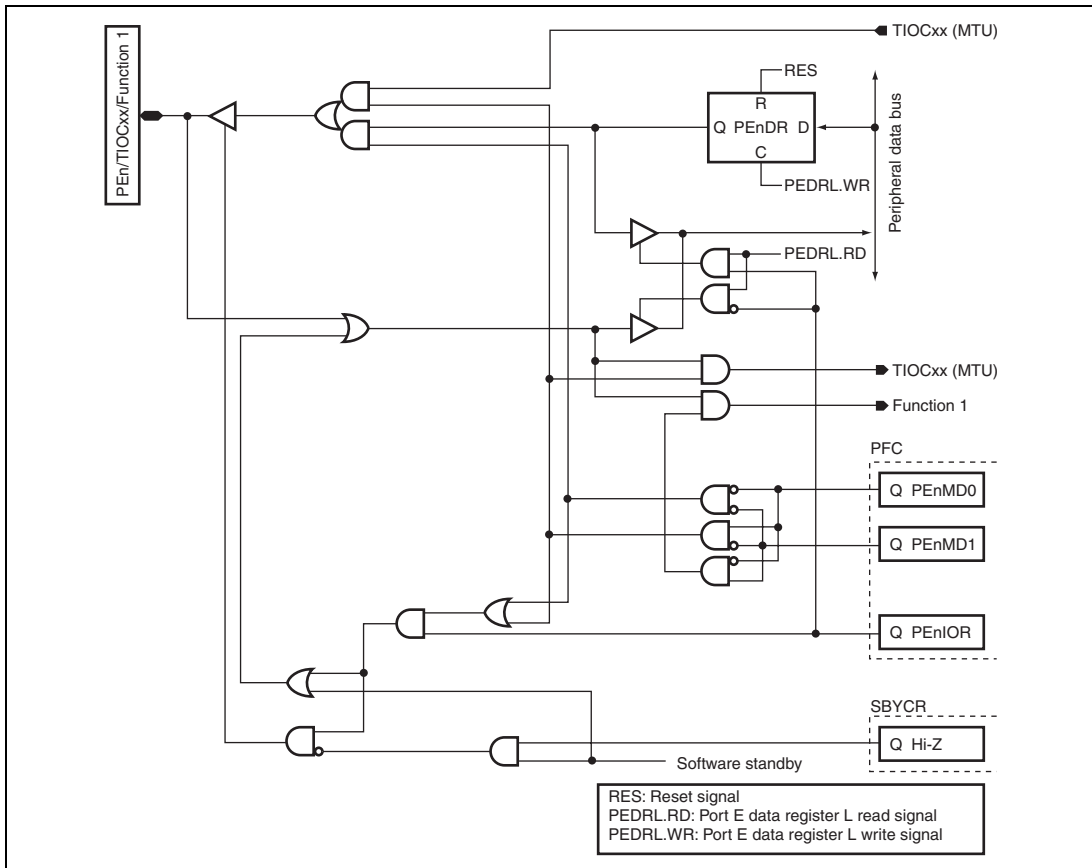

Figure D.34 PEEn/TIOCxx/Function 1

Symbol in Figure D.34

Available Products

| Pins | PEn | TIOCxx | Function 1 | Available Products | | | |
|----------------------|-----|-----------------|-----------------|--------------------|---|--------------------------|---|
| | | | | F-ZTAT version | SH7144 Masked ROM version/ ROM less version | SH7145 F-ZTAT version | SH7145 Masked ROM version/ ROM less version |
| PE0/TIOC0A/ DREQ0 | PE0 | TIOC0A (MTU) | DREQ0 (DMAC) | — | √ | — | √ |
| PE2/TIOC0C/ DREQ1 | PE2 | TIOC0C (MTU) | DREQ1 (DMAC) | — | √ | — | √ |
| PE4/TIOC1A/ RXD3 | PE4 | TIOC1A (MTU) | RXD3 (SCI) | — | √ | — | √ |
| PE7/TIOC2B/ RXD2 | PE7 | TIOC2B (MTU) | RXD2 (SCI) | √ | √ | √ | √ |

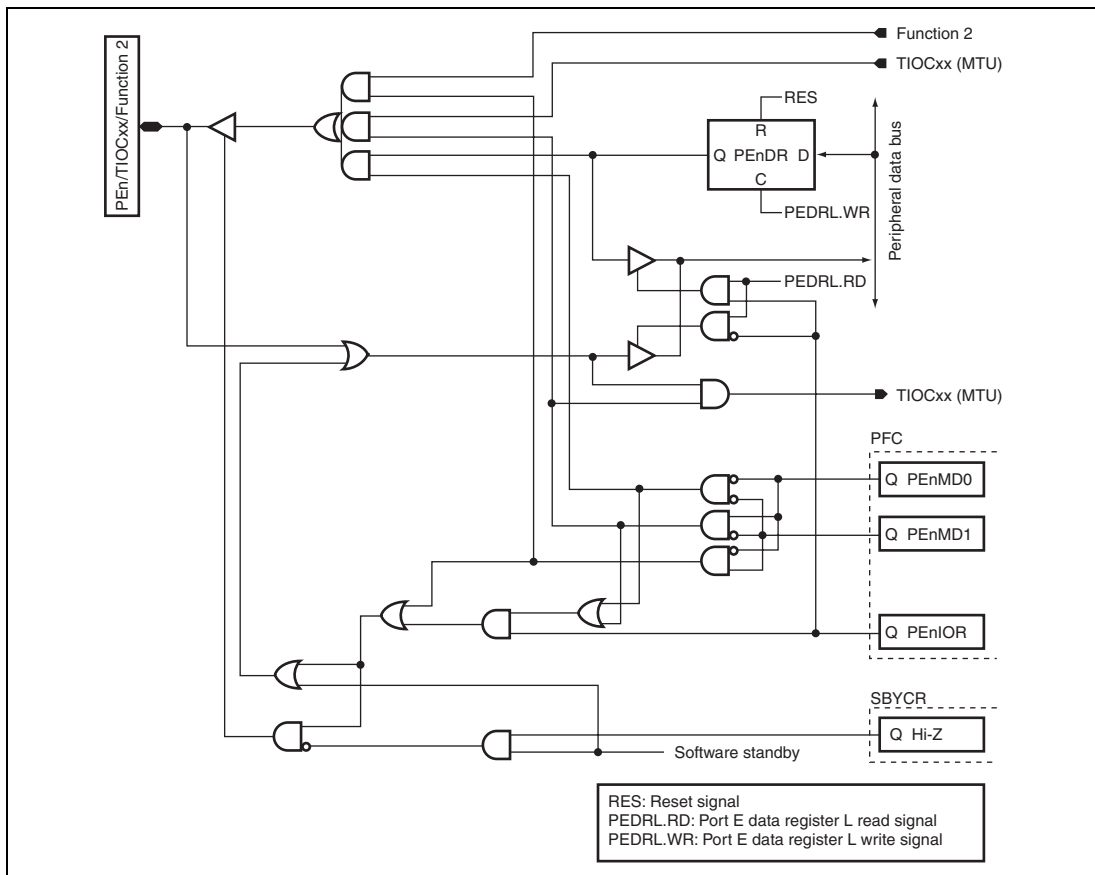

Figure D.35 PEEn/TIOCxx/Function 2

Symbol in Figure D.35

Available Products

| Pins | PEEn | TIOCxx | Function 2 | F-ZTAT version | SH7144 | | SH7145 | |
|------------------|------|--------------|--------------|----------------|-------------------------------------|----------------|-------------------------------------|----------------|
| | | | | | Masked ROM version/ROM less version | F-ZTAT version | Masked ROM version/ROM less version | F-ZTAT version |
| PE1/TIOC0B/DRAK0 | PE1 | TIOC0B (MTU) | DRAK0 (DMAC) | — | √ | — | √ | |
| PE3/TIOC0D/DRAK1 | PE3 | TIOC0D (MTU) | DRAK1 (DMAC) | — | √ | — | √ | |
| PE5/TIOC1B/TXD3 | PE5 | TIOC1B (MTU) | TXD3 (SCI) | √ | √ | — | √ | |
| PE10/TIOC3C/TXD2 | PE10 | TIOC3C (MTU) | TXD2 (SCI) | √ | √ | — | √ | |

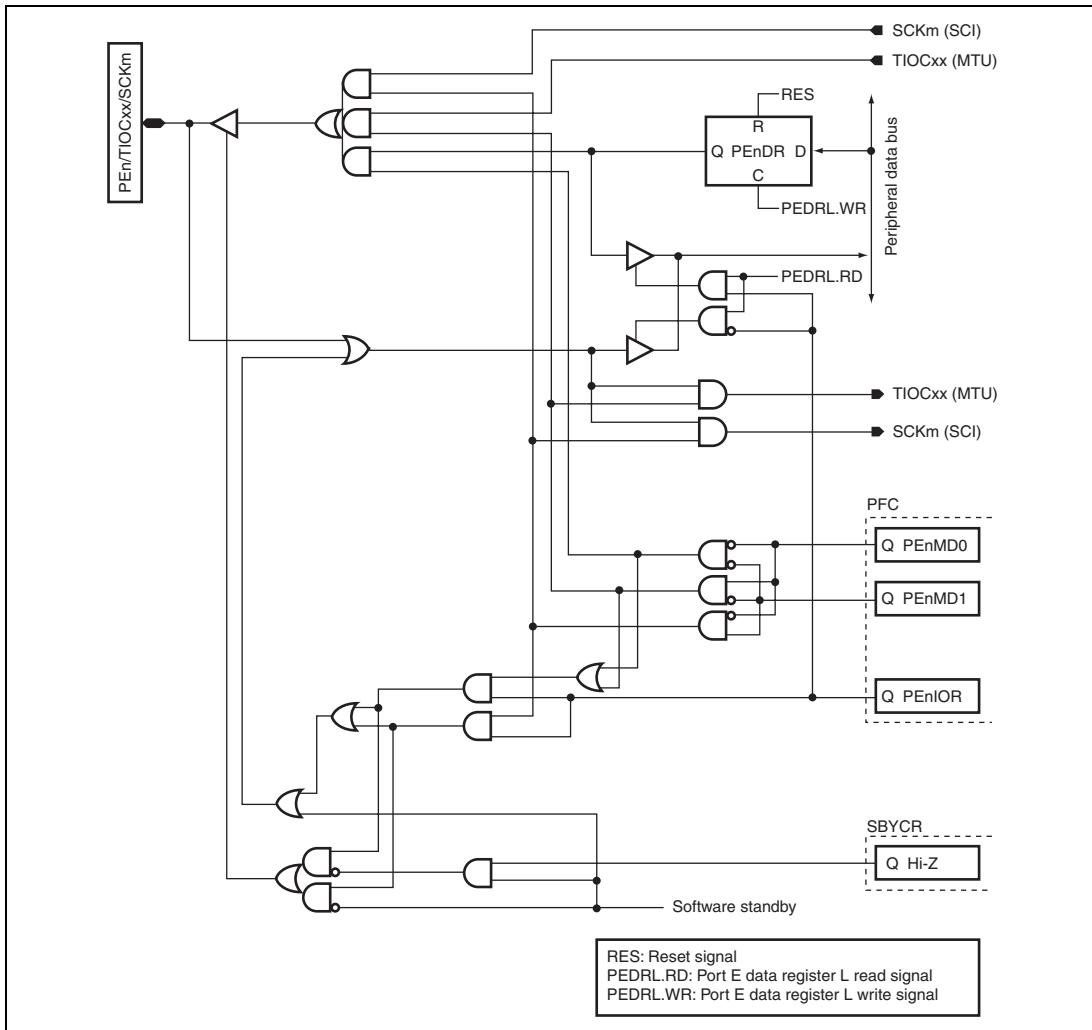

Figure D.36 PEn/TIOCxx/SCKm

| Pins | PE n | TIOCxx | SCKm | Available Products | | | |
|---------------------|------|-----------------|---------------|--------------------|---|----------------|---|
| | | | | SH7144 | | SH7145 | |
| | | | | F-ZTAT version | Masked ROM version/ ROM less version | F-ZTAT version | Masked ROM version/ ROM less version |
| PE9/TIOC3B/ SCK3 | PE9 | TIOC3B (MTU) | SCK3 (SCI) | √ | √ | — | √ |
| PE8/TIOC3A/ SCK2 | PE8 | TIOC3A (MTU) | SCK2 (SCI) | √ | √ | — | √ |

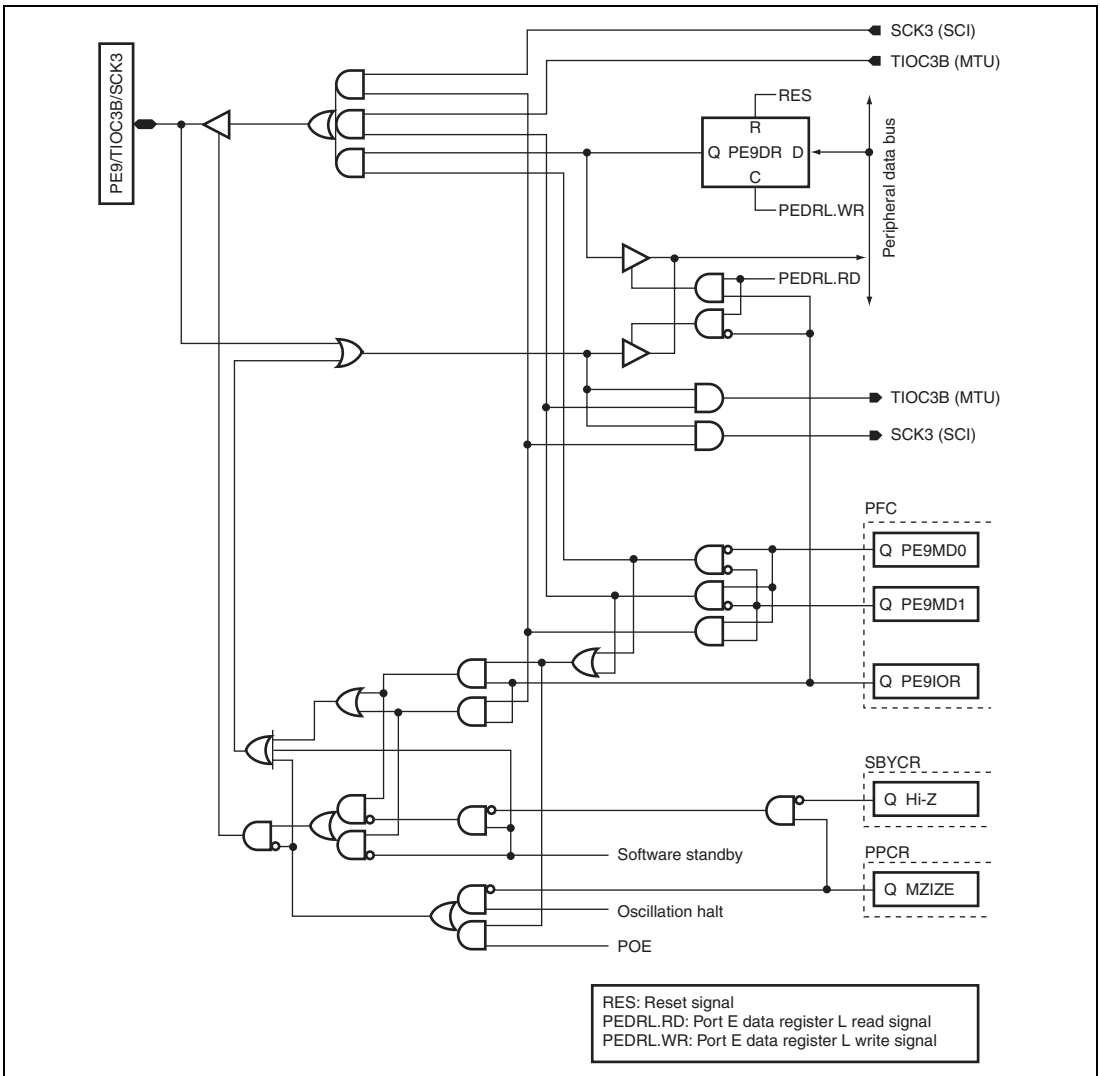

Figure D.37 PE9/TIOC3B/SCK3

Symbol in Figure D.37

Available Products

| Pins | PE9 | TIOC3B (MTU) | SCK3 (SCI) | F-ZTAT version | SH7144 | | SH7145 | |
|---------------------|-----|-----------------|---------------|-------------------|---|-------------------|---|-------------------|
| | | | | | Masked ROM version/ ROM less version | F-ZTAT version | Masked ROM version/ ROM less version | F-ZTAT version |
| PE9/TIOC3B/ SCK3 | PE9 | TIOC3B (MTU) | SCK3 (SCI) | √ | √ | — | √ | |

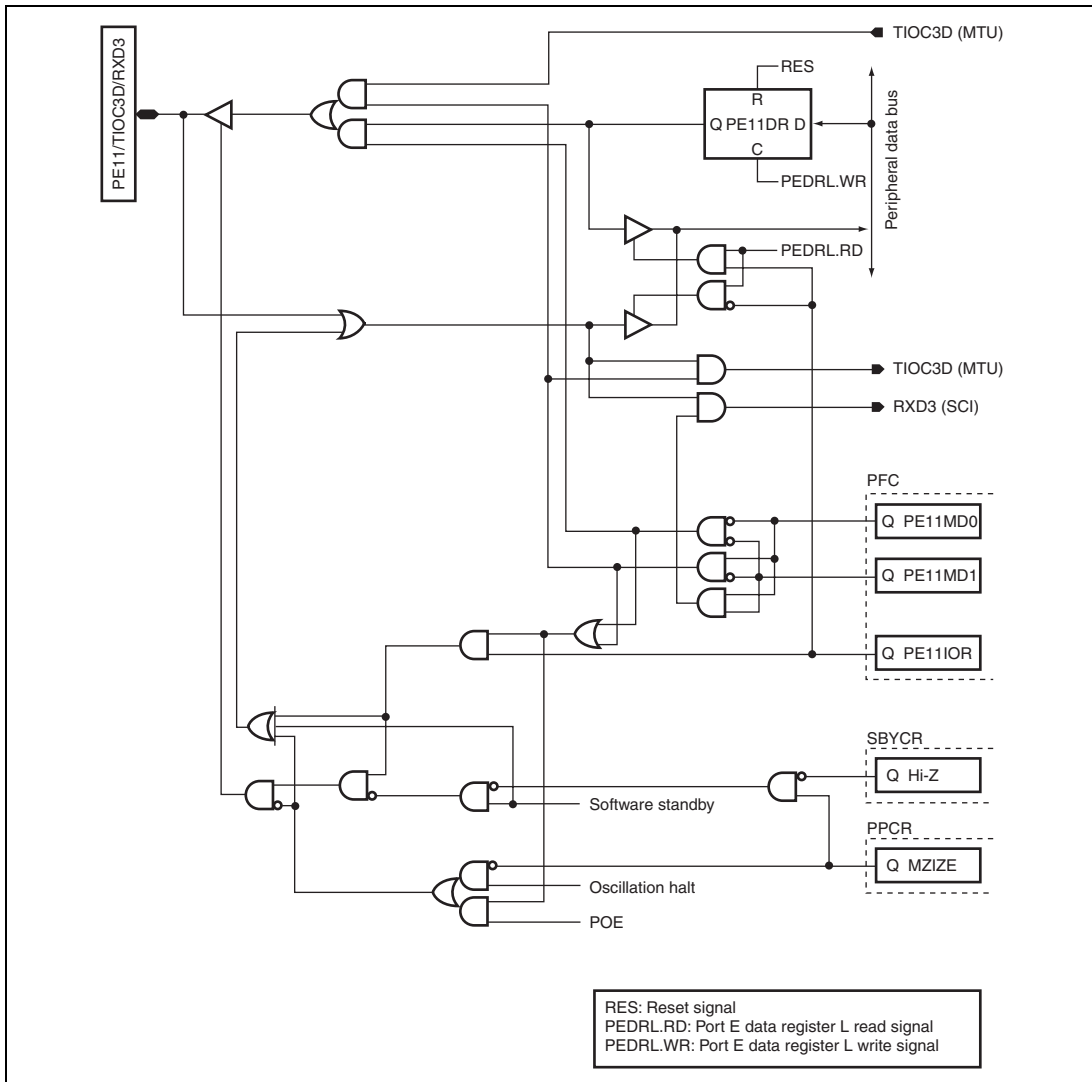

Figure D.38 PE11/TIOC3D/RXD3

Symbol in Figure D.38

Available Products

| Pins | PE11 | TIOC3D | RXD3 | F-ZTAT version | SH7144 | SH7145 |
|----------------------|------|-----------------|---------------|----------------|---|---|
| | | | | | Masked ROM version/ ROM less version | Masked ROM version/ ROM less version |
| PE11/TIOC3D/ RXD3 | PE11 | TIOC3D (MTU) | RXD3 (SCI) | √ | √ | — |

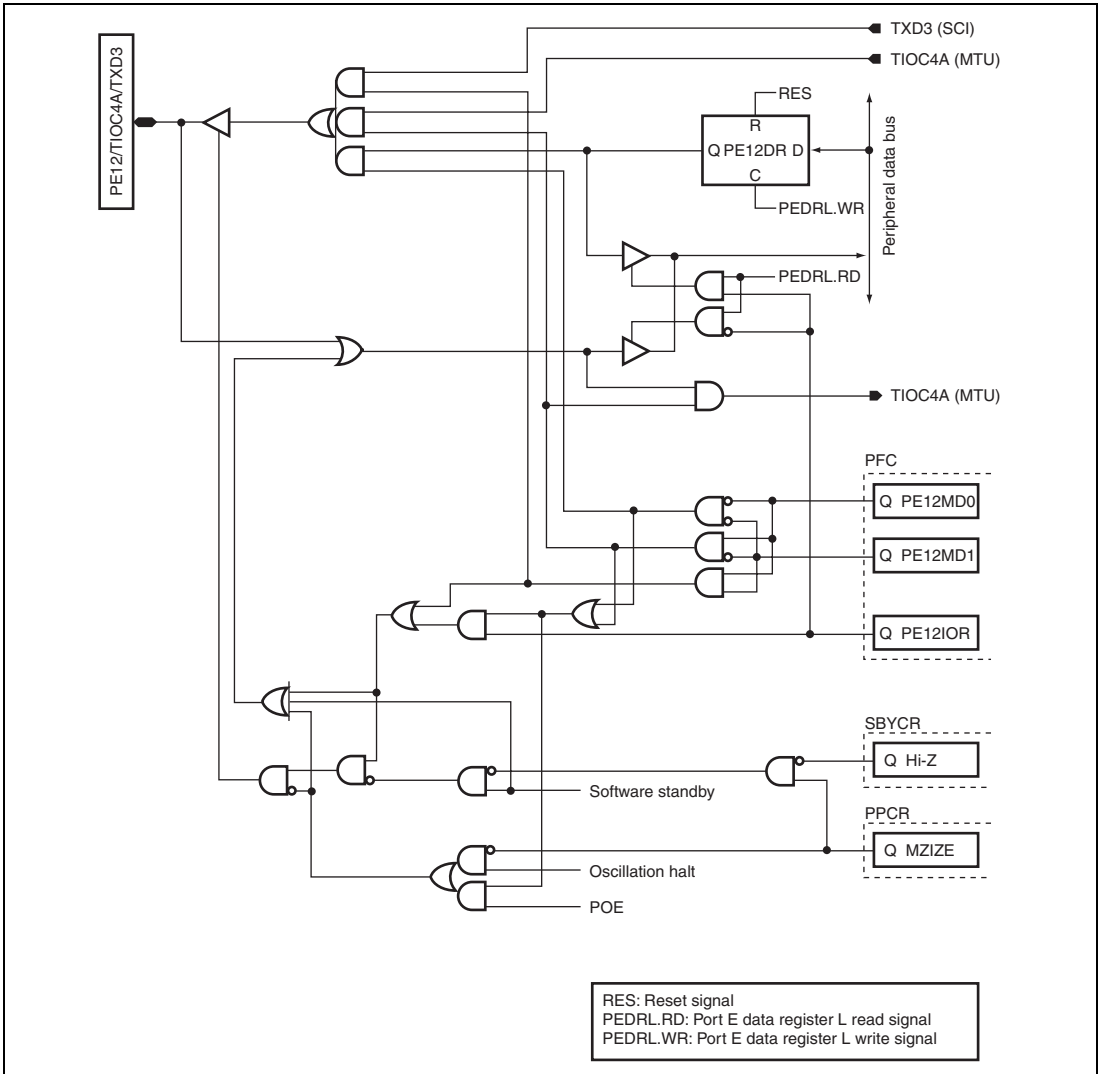

Figure D.39 PE12/TIOC4A/TXD3

Symbol in Figure D.39

Available Products

| Pins | Symbol in Figure D.39 | | | Available Products | | | |
|----------------------|-----------------------|-----------------|---------------|--------------------|---|--------------------------|---|
| | PE12 | TIOC4A | TXD3 | F-ZTAT version | SH7144 Masked ROM version/ ROM less version | SH7145 F-ZTAT version | SH7145 Masked ROM version/ ROM less version |
| PE12/TIOC4A/ TXD3 | PE12 | TIOC4A (MTU) | TXD3 (SCI) | √ | √ | — | √ |

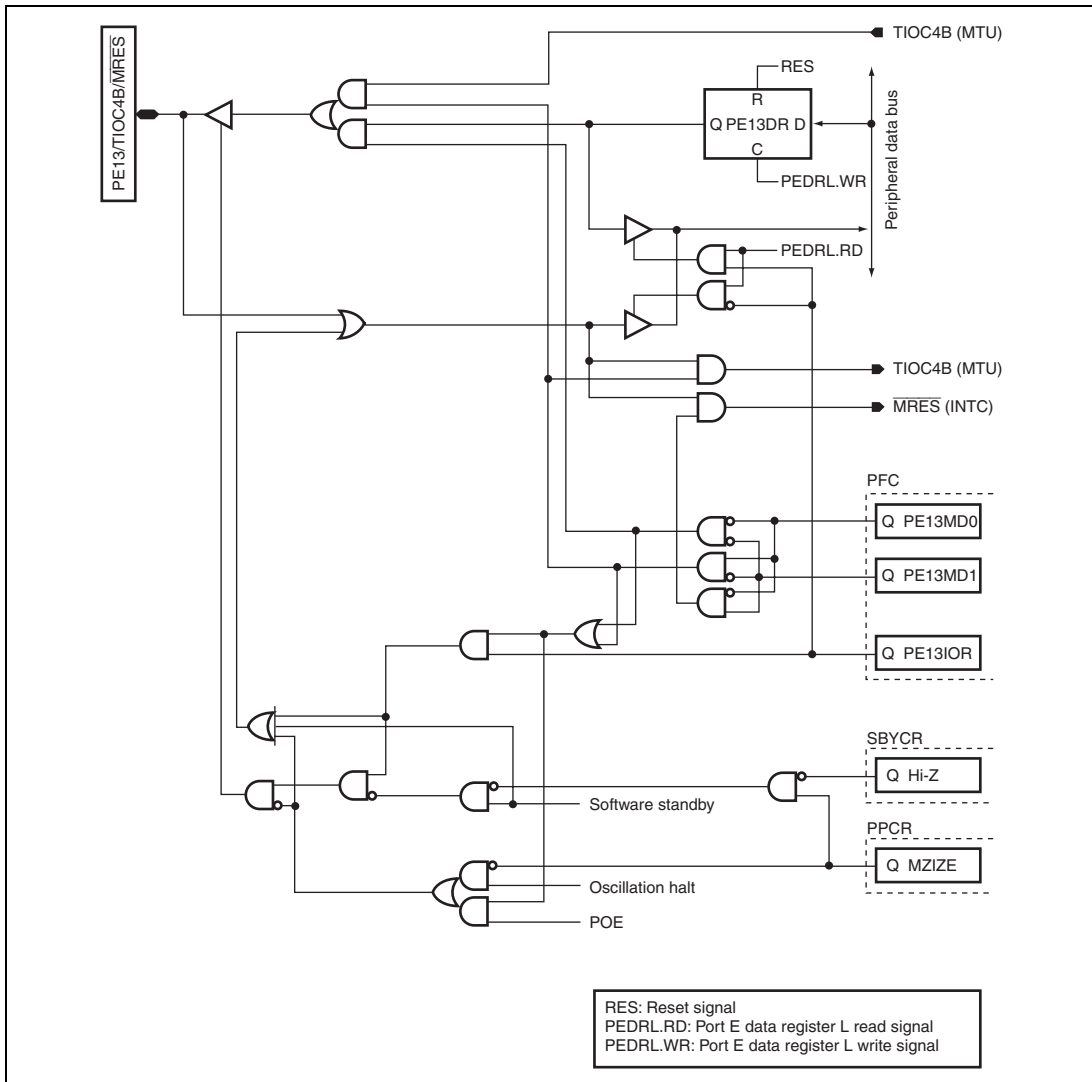

Figure D.40 PE13/TIOC4B/MRES

Symbol in Figure D.40

Available Products

| Pins | Symbol in Figure D.40 | | | Available Products | | | |
|----------------------|-----------------------|-----------------|----------------|--------------------|--|-------------------|---|
| | PE13 | TIOC4B (MTU) | MRES (INTC) | F-ZTAT version | SH7144 Masked ROM version ROM less version | F-ZTAT version | SH7145 Masked ROM version/ ROM less version |
| PE13/TIOC4B/ MRES | PE13 | TIOC4B (MTU) | MRES (INTC) | ✓ | ✓ | ✓ | ✓ |

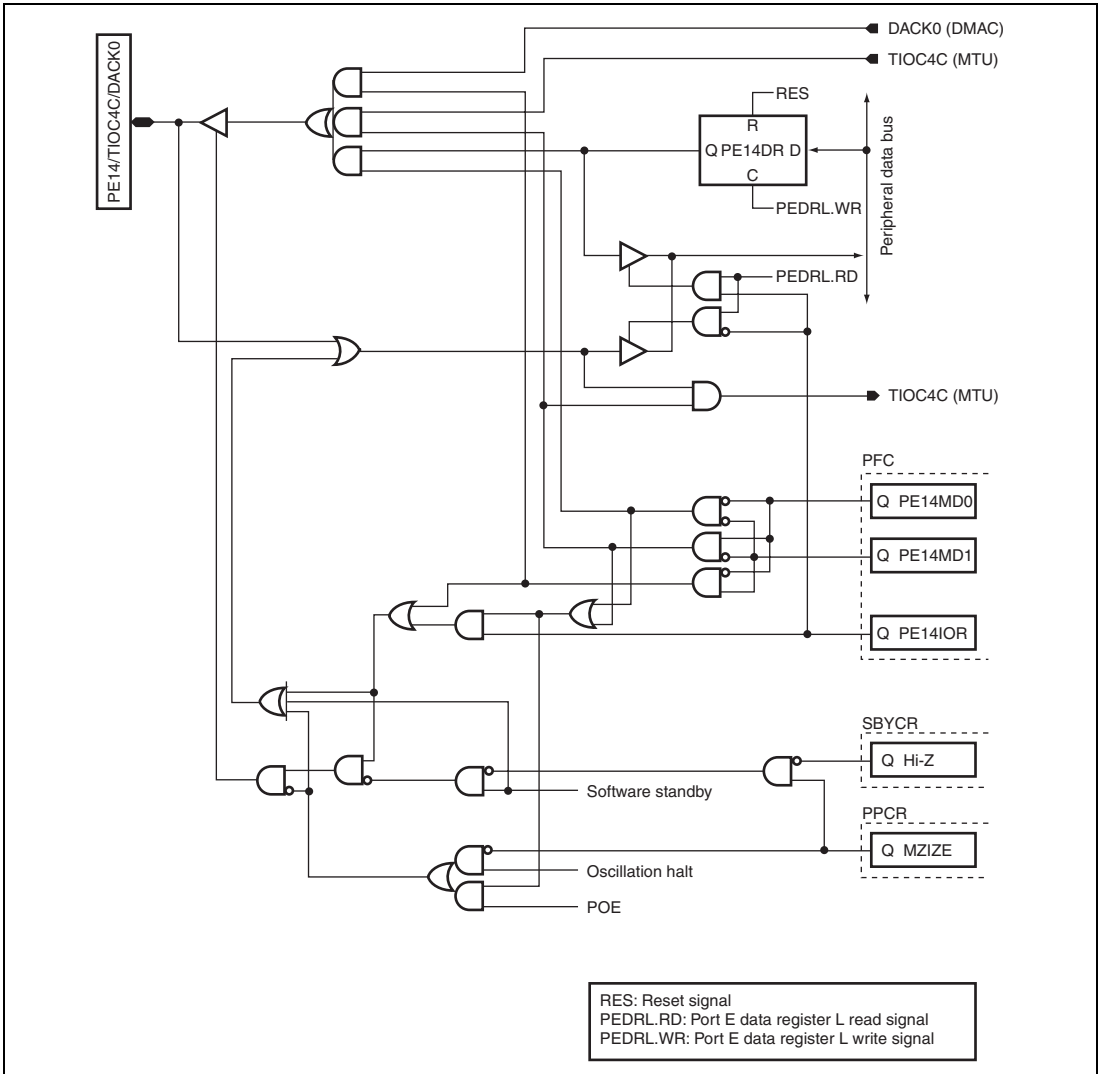

Figure D.41 PE14/TIOC4C/DACK0

Symbol in Figure D.41

Available Products

| Pins | PE14 | TIOC4C | DACK0 | Available Products | | | |
|-----------------------|------|-----------------|-----------------|--------------------|---|----------------|---|
| | | | | F-ZTAT version | SH7144 Masked ROM version/ ROM less version | F-ZTAT version | SH7145 Masked ROM version/ ROM less version |
| PE14/TIOC4C/ DACK0 | PE14 | TIOC4C (MTU) | DACK0 (DMAC) | √ | √ | √ | √ |

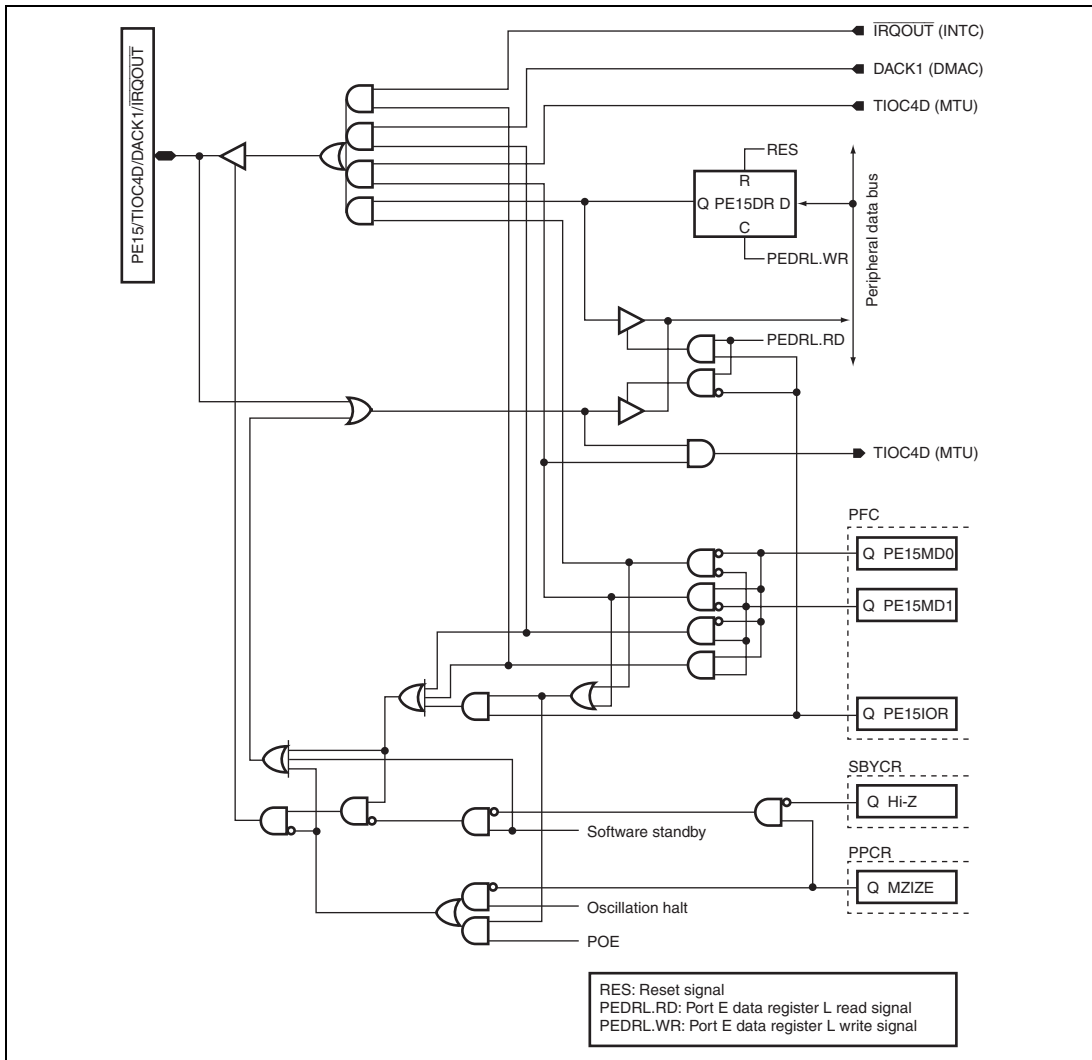

Figure D.42 PE15/TIOC4D/DACK1/IRQOUT

Symbol in Figure D.42

Available Products

| Pins | PE15 | TIOC4D | DACK1 | IRQOUT | Available Products | | | |
|----------------------------------|------|-----------------|-----------------|------------------|--------------------|---|----------------|---|
| | | | | | F-ZTAT version | Masked ROM version/ ROM less version | F-ZTAT version | Masked ROM version/ ROM less version |
| PE15/TIOC4D/ DACK1/ IRQOUT | PE15 | TIOC4D (MTU) | DACK1 (DMAC) | IRQOUT (INTC) | √ | √ | √ | √ |

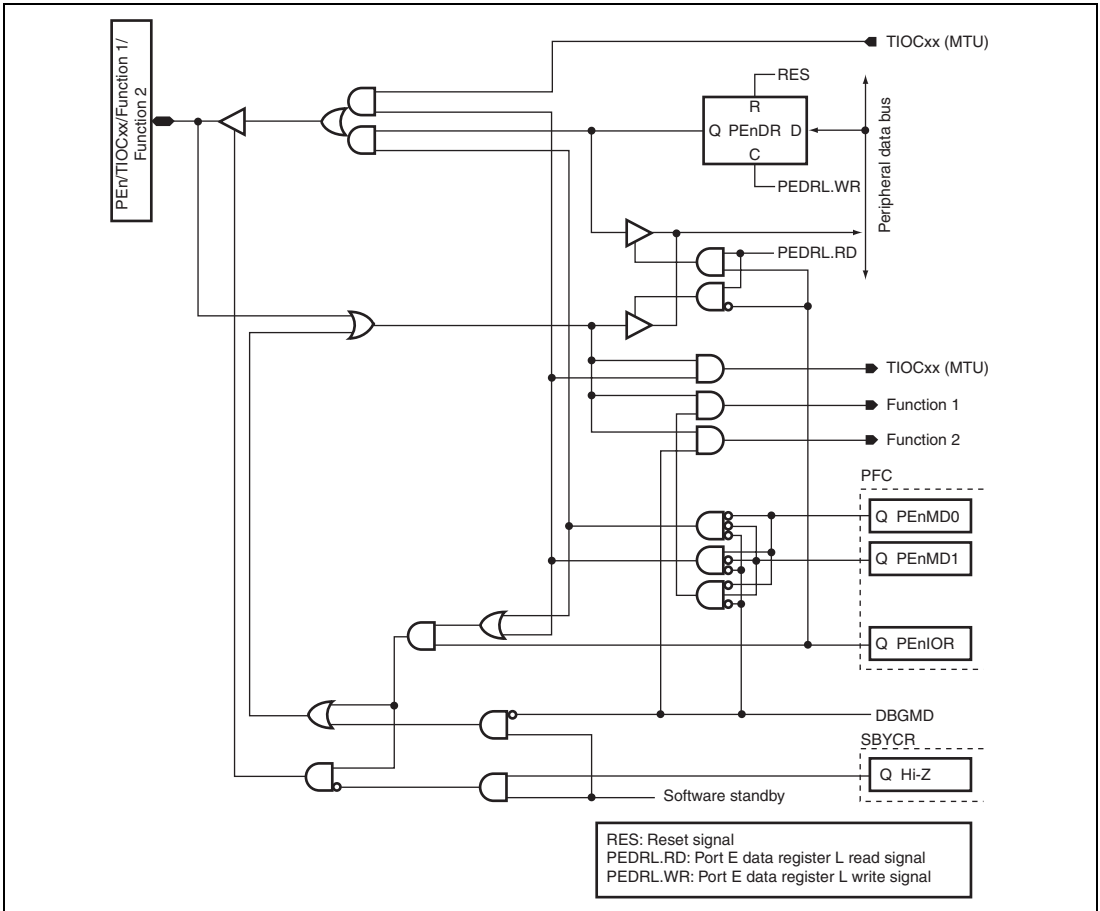

Figure D.43 PEEn/TIOCxx/Function 1/Function 2

Symbol in Figure D.43

Available Products

| Pins | PEn | TIOCxx | Function 1 | Function 2 | F-ZTAT version | Available Products | |
|--------------------------|-----|-----------------|-----------------|----------------|----------------|---|---|
| | | | | | | SH7144 | SH7145 |
| | | | | | | Masked ROM version/ ROM less version | Masked ROM version/ ROM less version |
| PE0/TIOC0A/ DREQ0/TMS | PE0 | TIOC0A (MTU) | DREQ0 (DMAC) | TMS (H-UDI) | √ | — | — |
| PE2/TIOC0C/ DREQ1/TDI | PE2 | TIOC0C (MTU) | DREQ1 (DMAC) | TDI (H-UDI) | √ | — | — |
| PE4/TIOC1A/ RXD3/TCK | PE4 | TIOC1A (MTU) | RXD3 (SCI) | TCK (H-UDI) | √ | — | — |

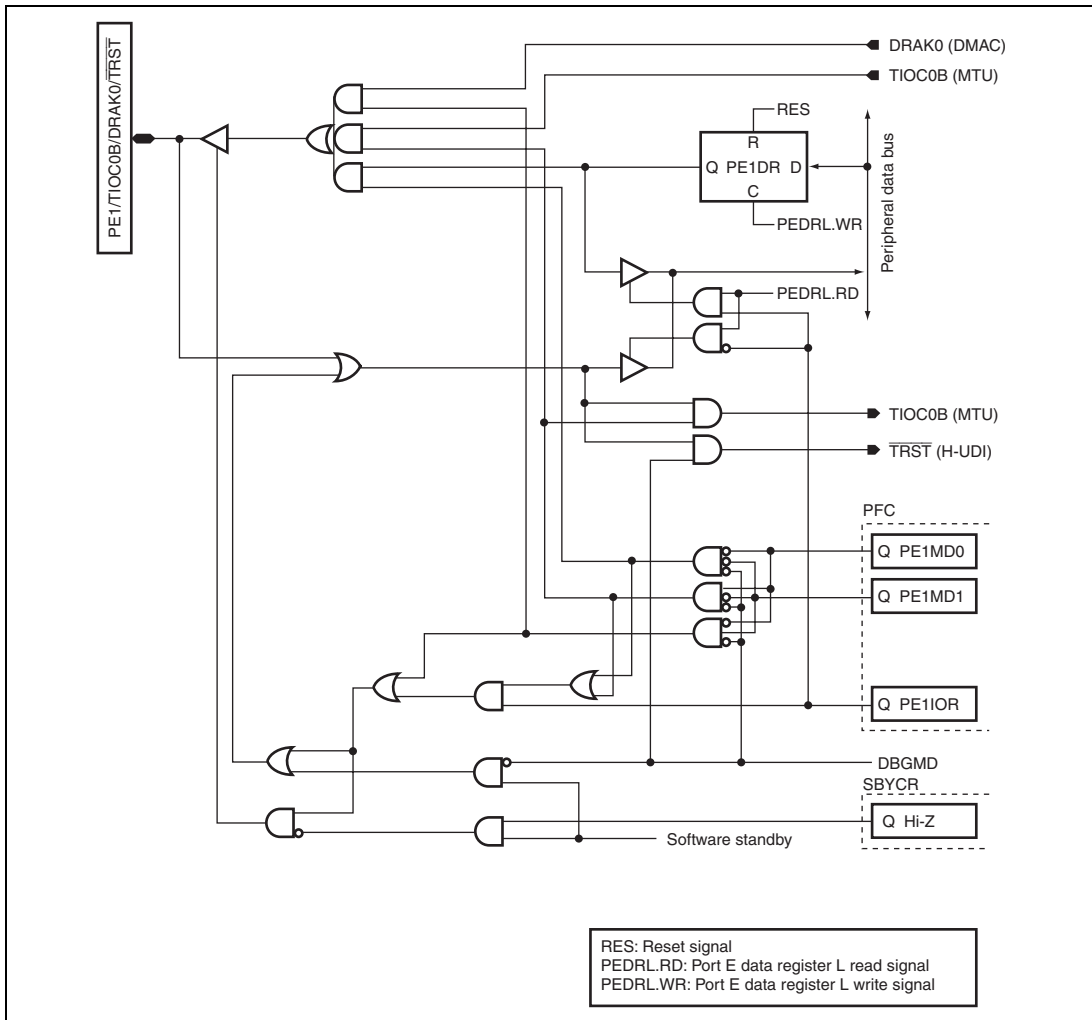

Figure D.44 PE1/TIOC0B/DRAK0/TRST

Symbol in Figure D.44

Available Products

| Pins | PE1 | TIOC0B | DRAK0 | TRST | SH7144 | | | SH7145 | |
|-------------------------------|-----|-----------------|-----------------|-----------------|----------------|---|----------------|---|--|
| | | | | | F-ZTAT version | Masked ROM version/ ROM less version | F-ZTAT version | Masked ROM version/ ROM less version | |
| PE1/TIOC0B/ DRAK0/ TRST | PE1 | TIOC0B (MTU) | DRAK0 (DMAC) | TRST (H-UDI) | √ | — | — | — | |

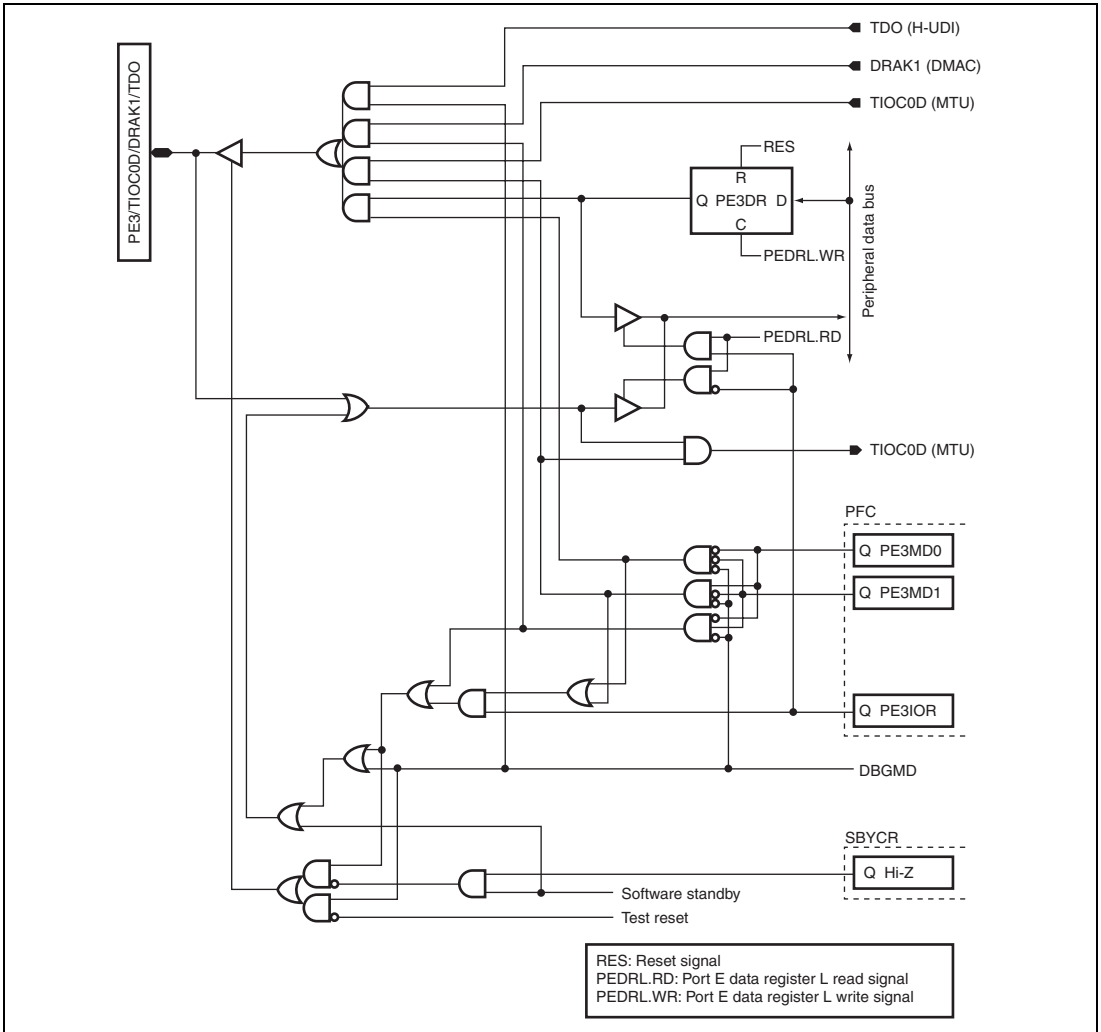

Figure D.45 PE3/TIOC0D/DRAK1/TDO

Symbol in Figure D.45

Available Products

| Pins | PE3 | TIOC0D (MTU) | DRAK1 (DMAC) | TDO (H-UDI) | Available Products | | | |
|--------------------------|-----|-----------------|-----------------|----------------|--------------------|---|-------------------|---|
| | | | | | F-ZTAT version | SH7144 Masked ROM version/ ROM less version | F-ZTAT version | SH7145 Masked ROM version/ ROM less version |
| PE3/TIOC0D/ DRAK1/TDO | PE3 | TIOC0D (MTU) | DRAK1 (DMAC) | TDO (H-UDI) | ✓ | — | — | — |

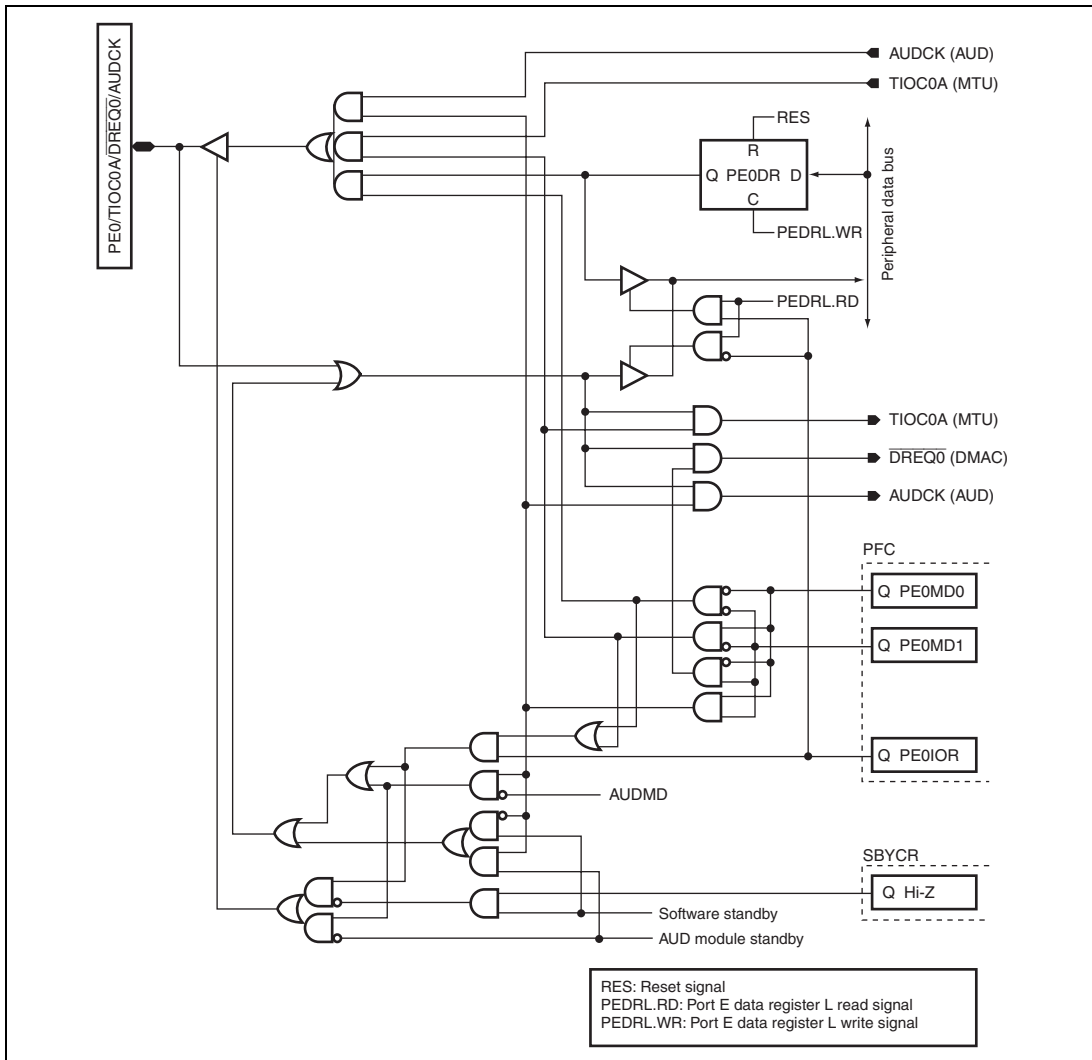

Figure D.46 PE0/TIOC0A/DREQ0/AUDCK

| Symbol in Figure D.46 | Available Products | |
|--------------------------------|--|---|
| | SH7144 | SH7145 |
| | Masked ROM version/ ROM less version | Masked ROM version/ ROM less version |
| Pins | F-ZTAT version | F-ZTAT version |
| PE0/TIOC0A/ DREQ0/ AUDCK | PE0 TIOC0A (MTU) DREQ0 (DMAC) AUDCK (AUD) | — — √ — |

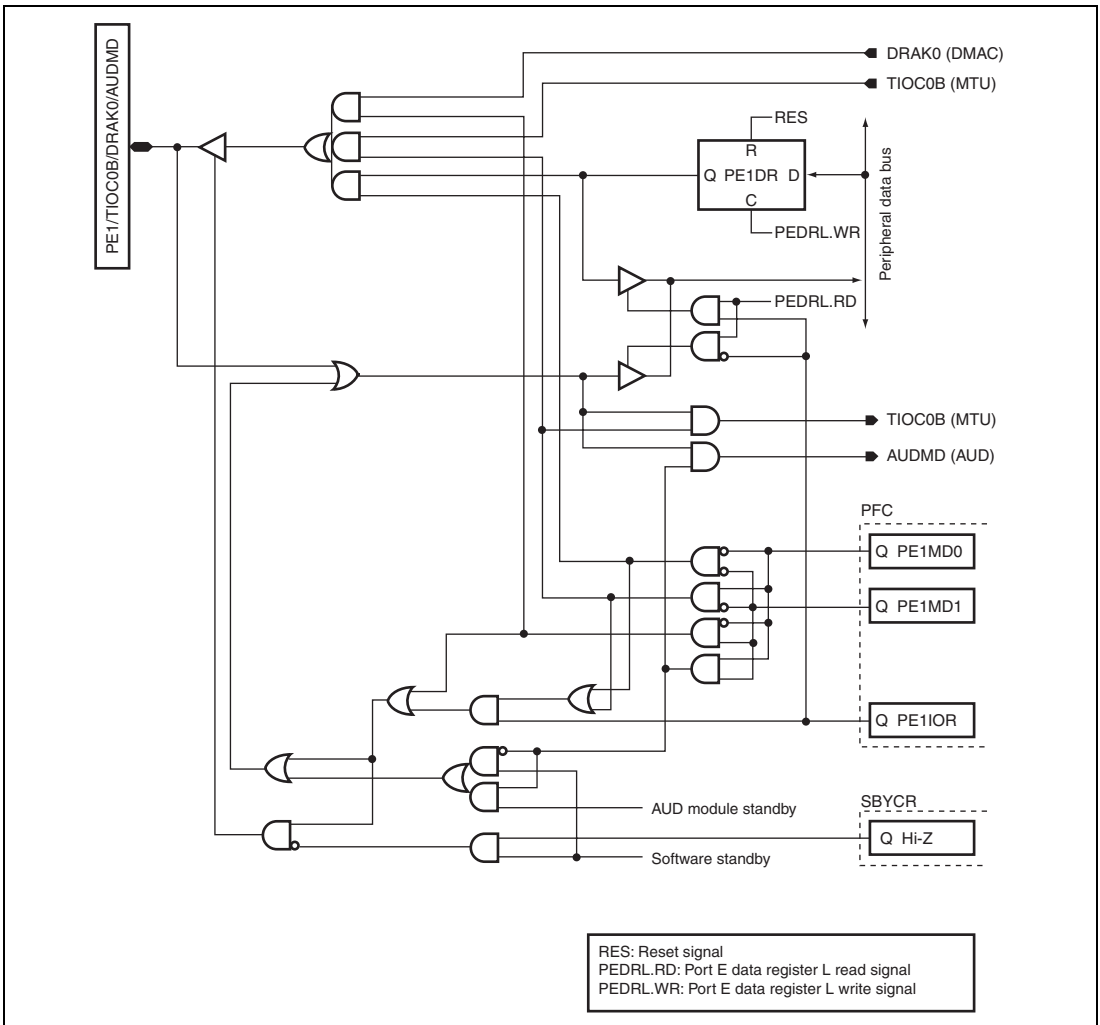

Figure D.47 PE1/TIOC0B/DRAK0/AUDMD

Symbol in Figure D.47

Available Products

| Pins | PE1 | TIOC0B | DRAK0 | AUDMD | Available Products | | | |
|--------------------------------|-----|-----------------|-----------------|----------------|--|--|--|--|
| | | | | | SH7144 | | SH7145 | |
| | | | | | Masked ROM version/ F-ZTAT ROM less version | Masked ROM version/ F-ZTAT ROM less version | Masked ROM version/ F-ZTAT ROM less version | Masked ROM version/ F-ZTAT ROM less version |
| PE1/TIOC0B/ DRAK0/ AUDMD | PE1 | TIOC0B (MTU) | DRAK0 (DMAC) | AUDMD (AUD) | — | — | √ | — |

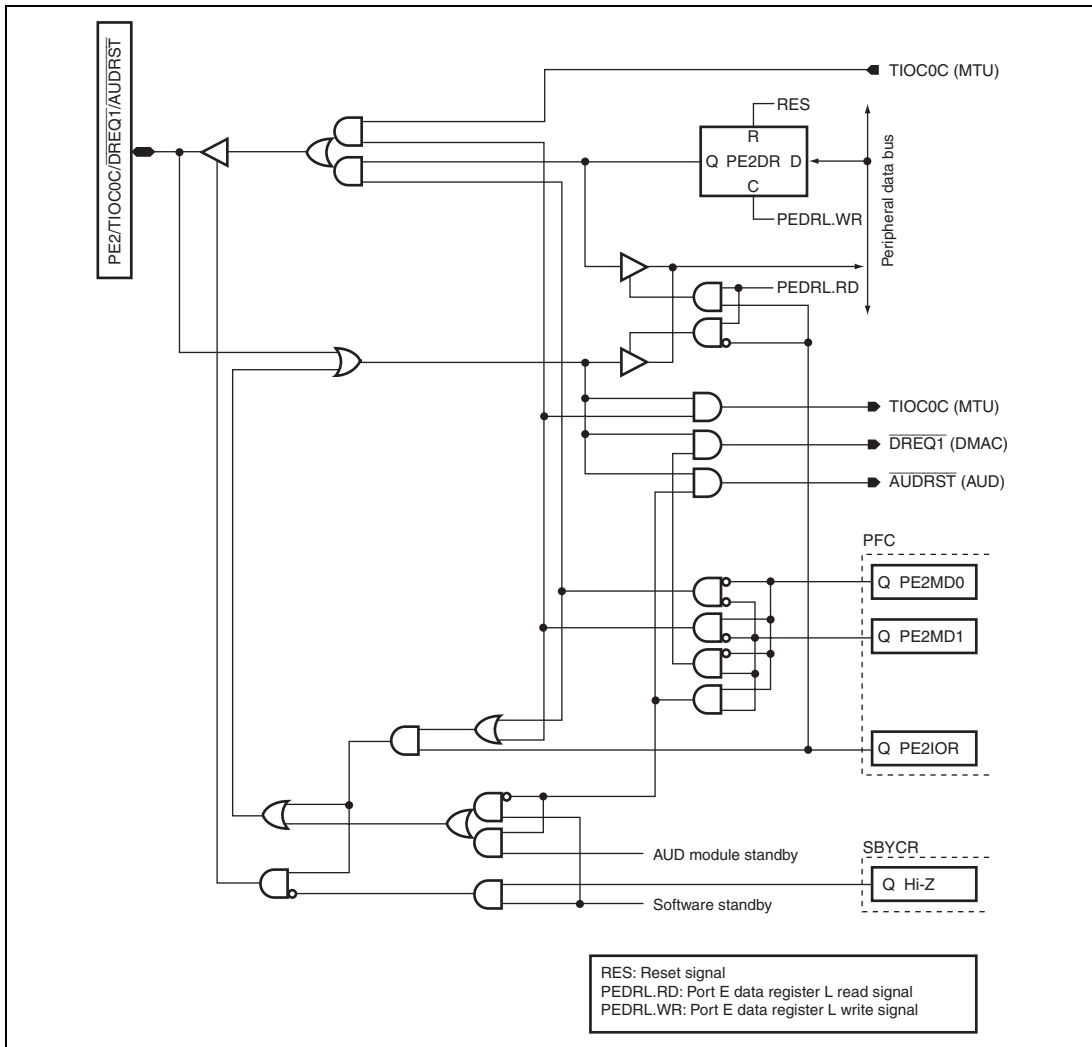

Figure D.48 PE2/TIOC0C/DREQ1/AUDRST

Symbol in Figure D.48

Available Products

| Pins | PE2 | TIOC0C | DREQ1 | AUDRST | SH7144 | | SH7145 | |
|---------------------------------|-----|-----------------|-----------------|-----------------|----------------|---|----------------|---|
| | | | | | F-ZTAT version | Masked ROM version/ ROM less version | F-ZTAT version | Masked ROM version/ ROM less version |
| PE2/TIOC0C/ DREQ1/ AUDRST | PE2 | TIOC0C (MTU) | DREQ1 (DMAC) | AUDRST (AUD) | — | — | √ | — |

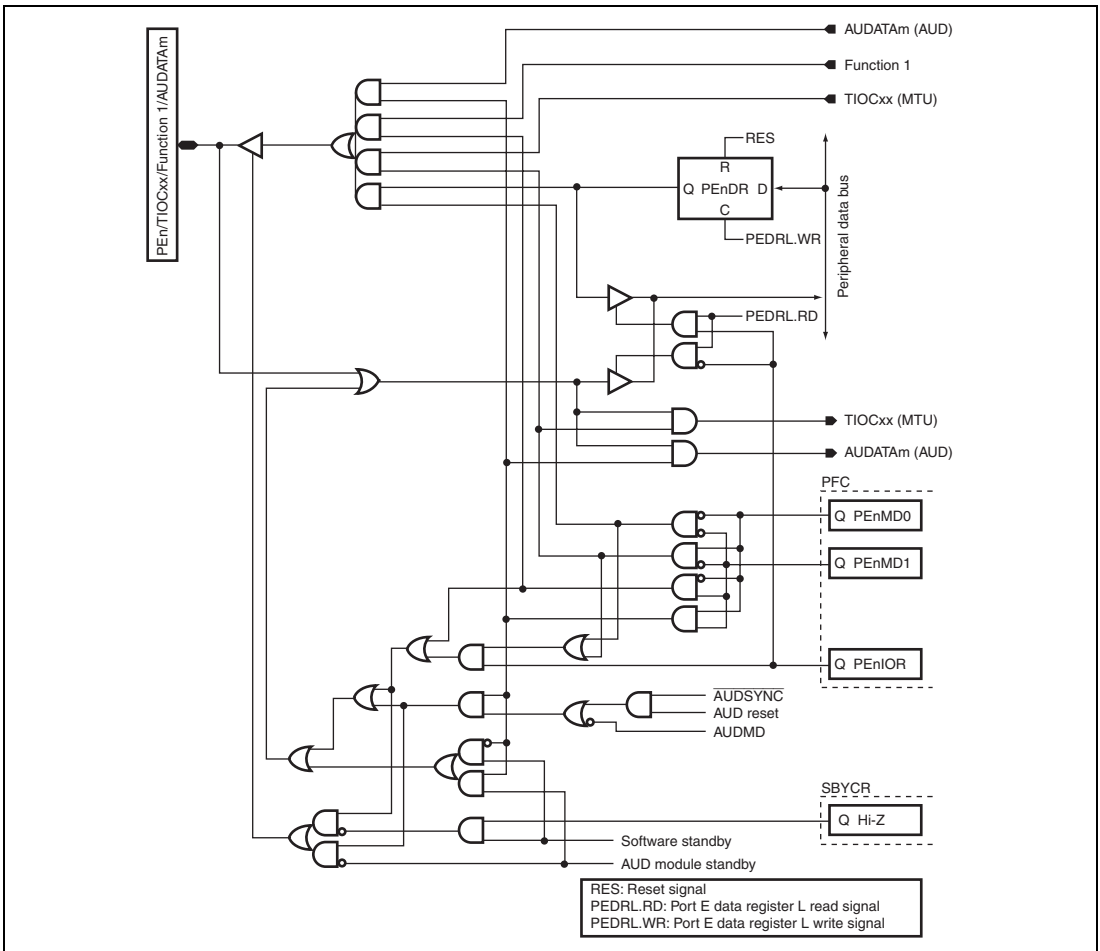

Figure D.49 PE n/TIOCxx/Function 1/AUDATAm

Symbol in Figure D.49

Available Products

| Pins | PE n | TIOCxx | Function 1 | AUDATAm | SH7144 | | SH7145 | |
|----------------------------------|------|-----------------|-----------------|------------------|----------------|---|----------------|---|
| | | | | | F-ZTAT version | Masked ROM version/ ROM less version | F-ZTAT version | Masked ROM version/ ROM less version |
| PE3/TIOC0D/ DRAK1/ AUDATA3 | PE3 | TIOC0D (MTU) | DRAK1 (DMAC) | AUDATA3 (AUD) | — | — | √ | — |
| PE5/TIOC1B/ TXD3/ AUDATA1 | PE5 | TIOC1B (MTU) | TXD3 (SCI) | AUDATA1 (AUD) | — | — | √ | — |

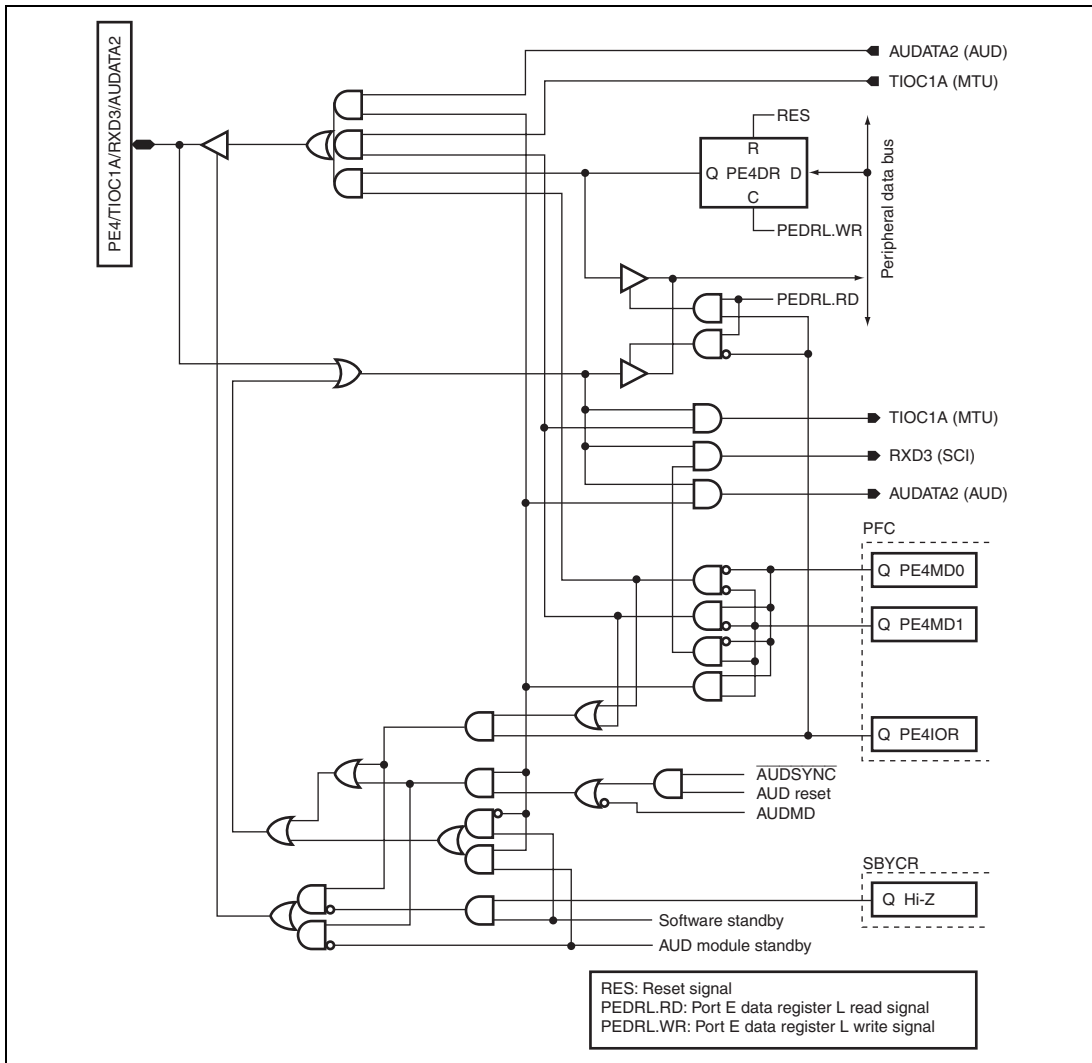

Figure D.50 PE4/TIOC1A/RXD3/AUDATA2

Symbol in Figure D.50

Available Products

| Pins | PE4 | TIOC1A | RXD3 | AUDATA2 | F-ZTAT version | Available Products | |
|---------------------------------|-----|-----------------|---------------|------------------|----------------|-------------------------------------|-------------------------------------|
| | | | | | | SH7144 | SH7145 |
| | | | | | | Masked ROM version/ROM less version | Masked ROM version/ROM less version |
| PE4/TIOC1A/ RXD3/ AUDATA2 | PE4 | TIOC1A (MTU) | RXD3 (SCI) | AUDATA2 (AUD) | — | — | √ |

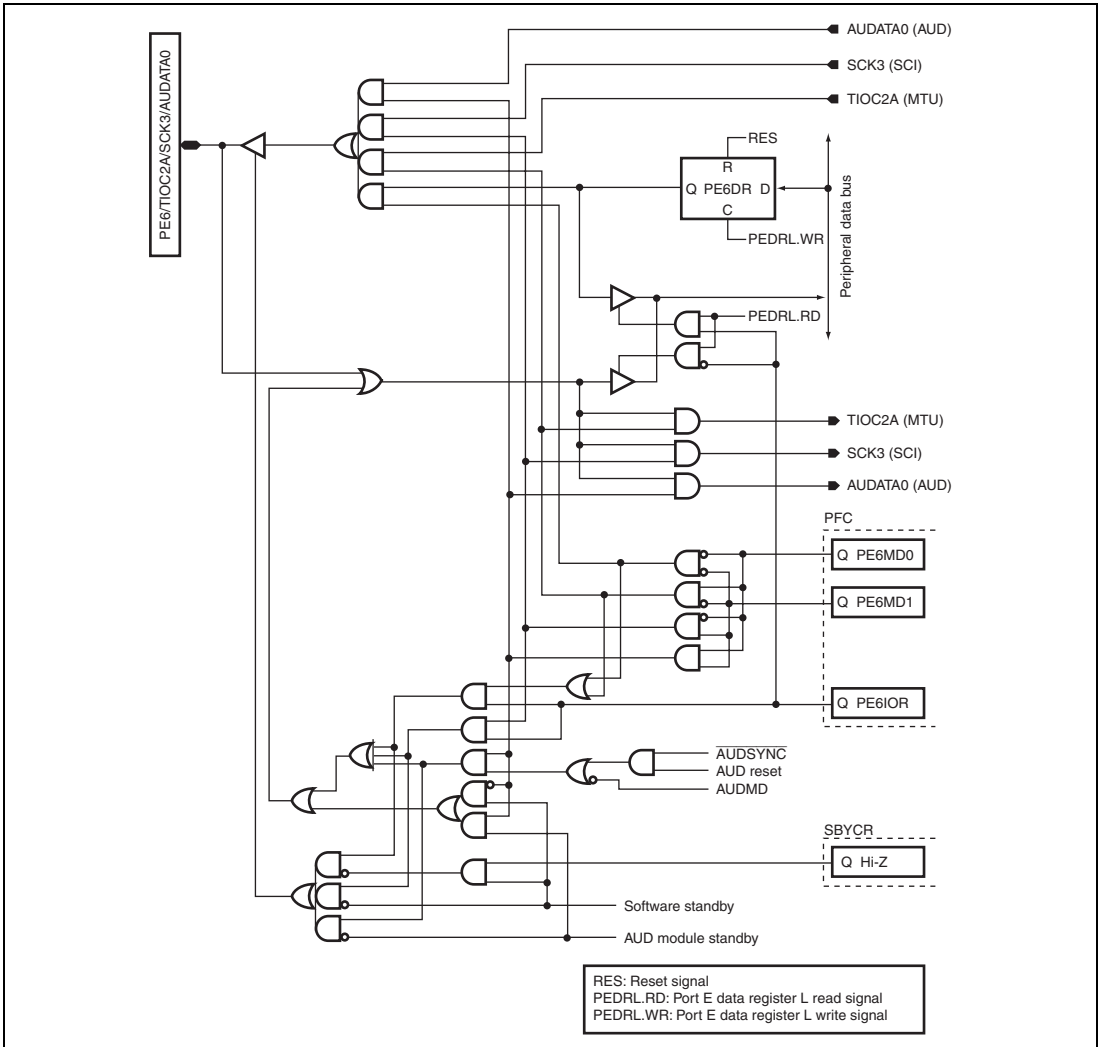

Figure D.51 PE6/TIOC2A/SCK3/AUDATA0

Symbol in Figure D.51

Available Products

| Pins | PE6 | TIOC2A | SCK3 | AUDATA0 | SH7144 | | SH7145 | |
|---------------------------------|-----|-----------------|---------------|------------------|----------------|---|----------------|---|
| | | | | | F-ZTAT version | Masked ROM version/ ROM less version | F-ZTAT version | Masked ROM version/ ROM less version |
| PE6/TIOC2A/ SCK3/ AUDATA0 | PE6 | TIOC2A (MTU) | SCK3 (SCI) | AUDATA0 (AUD) | — | — | √ | — |

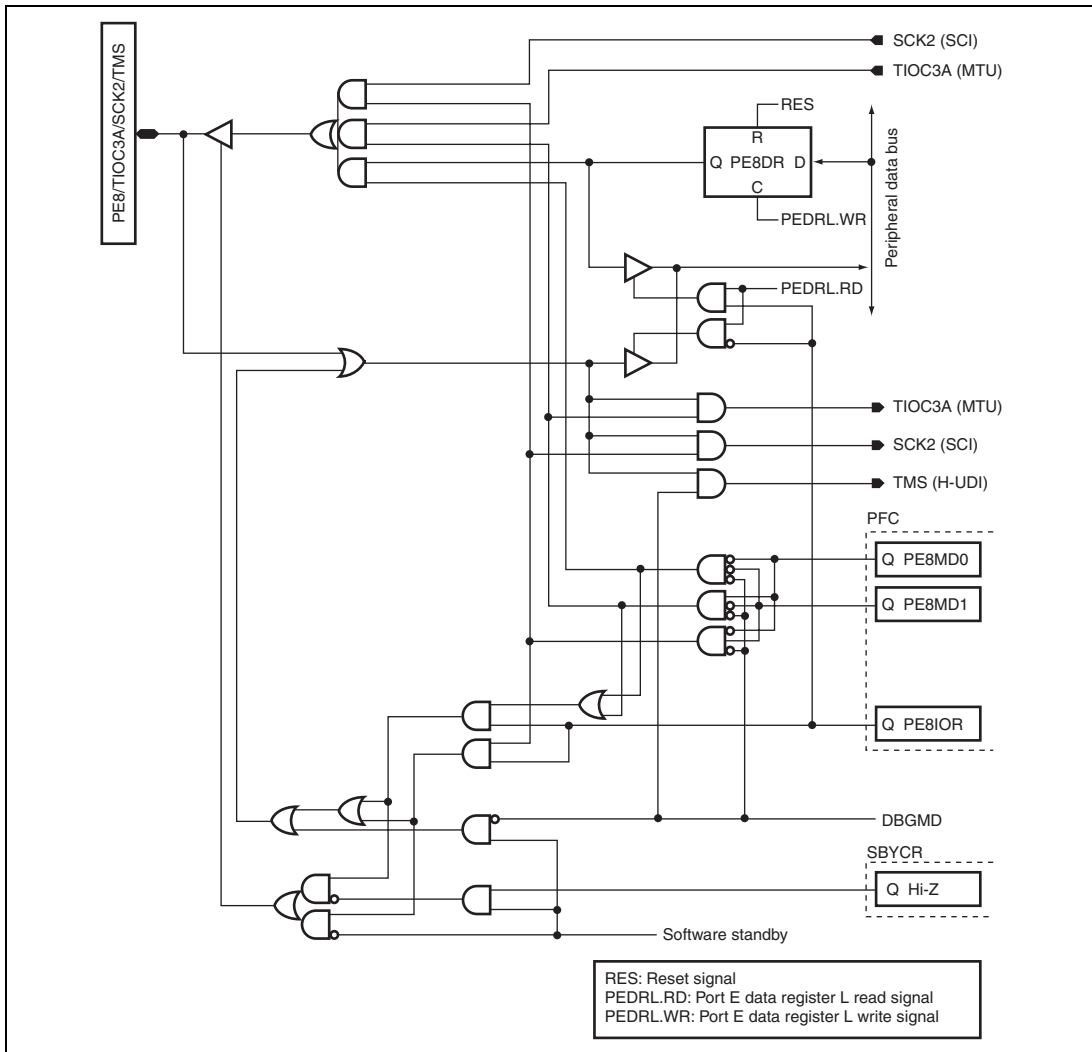

Figure D.52 PE8/TIOC3A/SCK2/TMS

Symbol in Figure D.52

Available Products

| Pins | PE8 | TIOC3A | SCK2 | TMS | Available Products | | | |
|-------------------------|-----|-----------------|---------------|----------------|---|---|--------|---|
| | | | | | F-ZTAT version | SH7144 | SH7145 | |
| | | | | | Masked ROM version/ ROM less version | Masked ROM version/ ROM less version | | |
| PE8/TIOC3A/ SCK2/TMS | PE8 | TIOC3A (MTU) | SCK2 (SCI) | TMS (H-UDI) | — | — | √ | — |

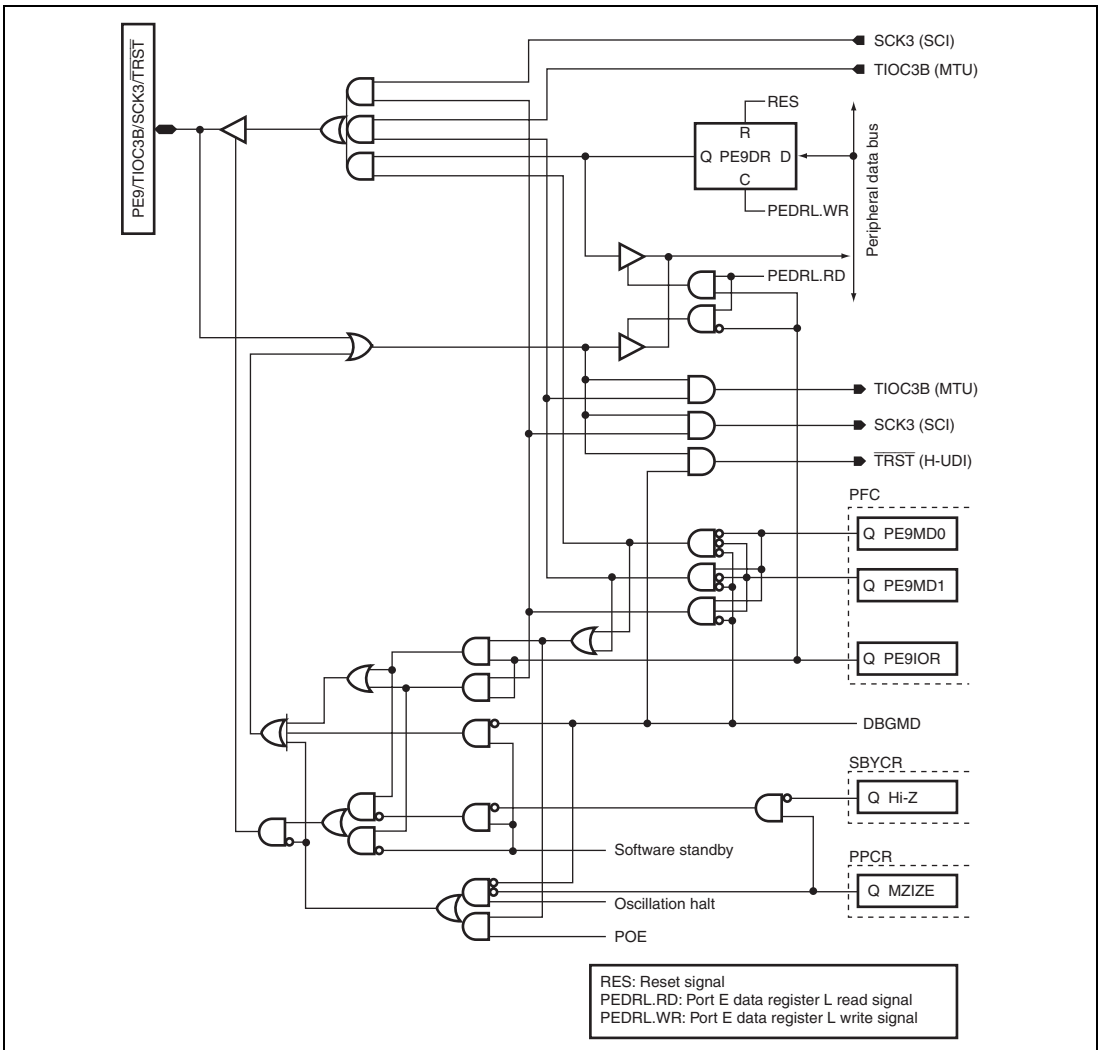

Figure D.53 PE9/TIOC3B/SCK3/TRST

Symbol in Figure D.53

Available Products

| Pins | PE9 | TIOC3B (MTU) | SCK3 (SCI) | TRST (H-UDI) | Available Products | | | |
|--------------------------|-----|-----------------|---------------|-----------------|--------------------|---|---|-------------------|
| | | | | | F-ZTAT version | SH7144 Masked ROM version/ ROM less version | SH7145 Masked ROM version/ ROM less version | F-ZTAT version |
| PE9/TIOC3B/ SCK3/TRST | PE9 | TIOC3B (MTU) | SCK3 (SCI) | TRST (H-UDI) | — | — | √ | — |

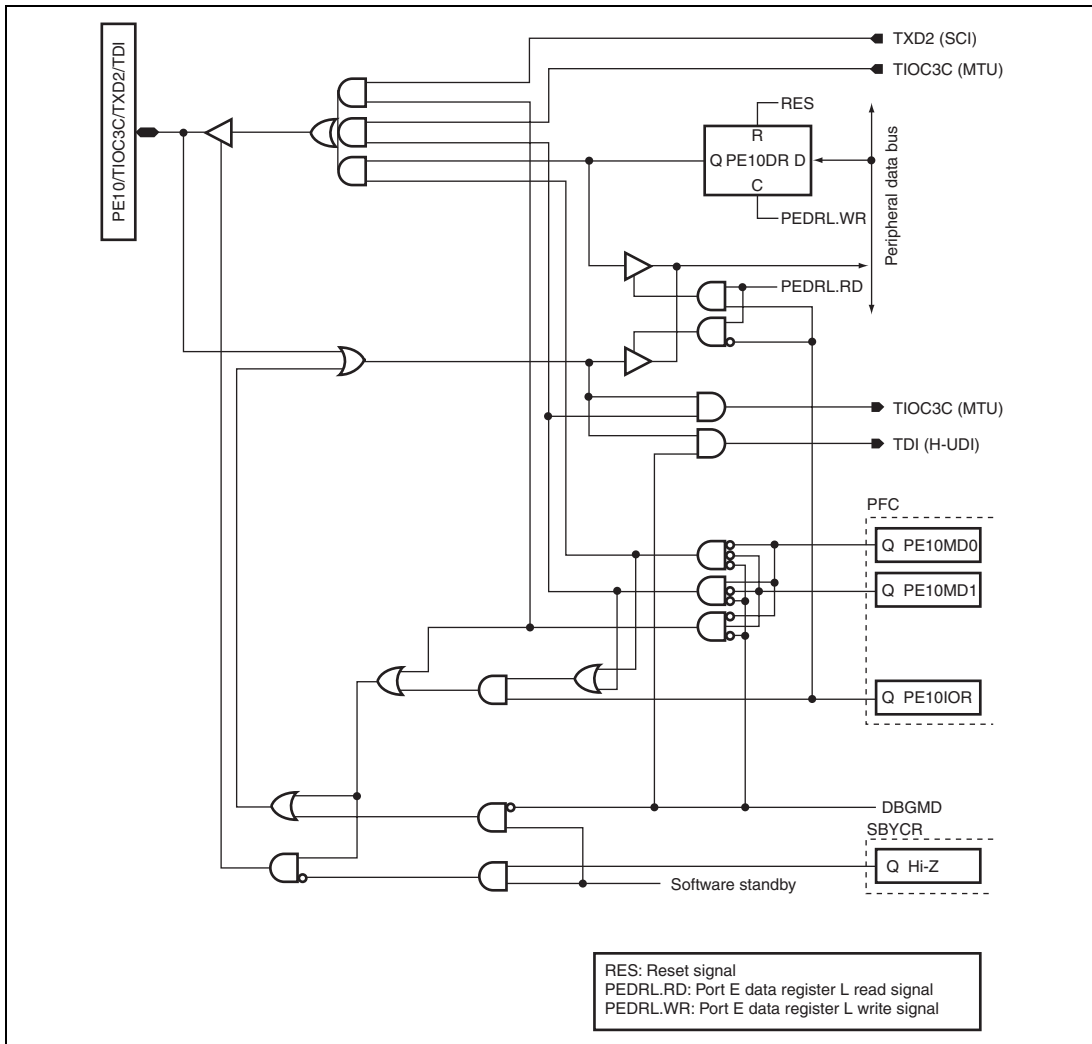

Figure D.54 PE10/TIOC3C/TXD2/TDI

Symbol in Figure D.54

Available Products

| Pins | PE10 | TIOC3C | TXD2 | TDI | Available Products | | | |
|--------------------------|------|-----------------|---------------|----------------|--------------------|---|----------------|---|
| | | | | | F-ZTAT version | Masked ROM version/ ROM less version | F-ZTAT version | Masked ROM version/ ROM less version |
| PE10/TIOC3C/ TXD2/TDI | PE10 | TIOC3C (MTU) | TXD2 (SCI) | TDI (H-UDI) | — | — | √ | — |

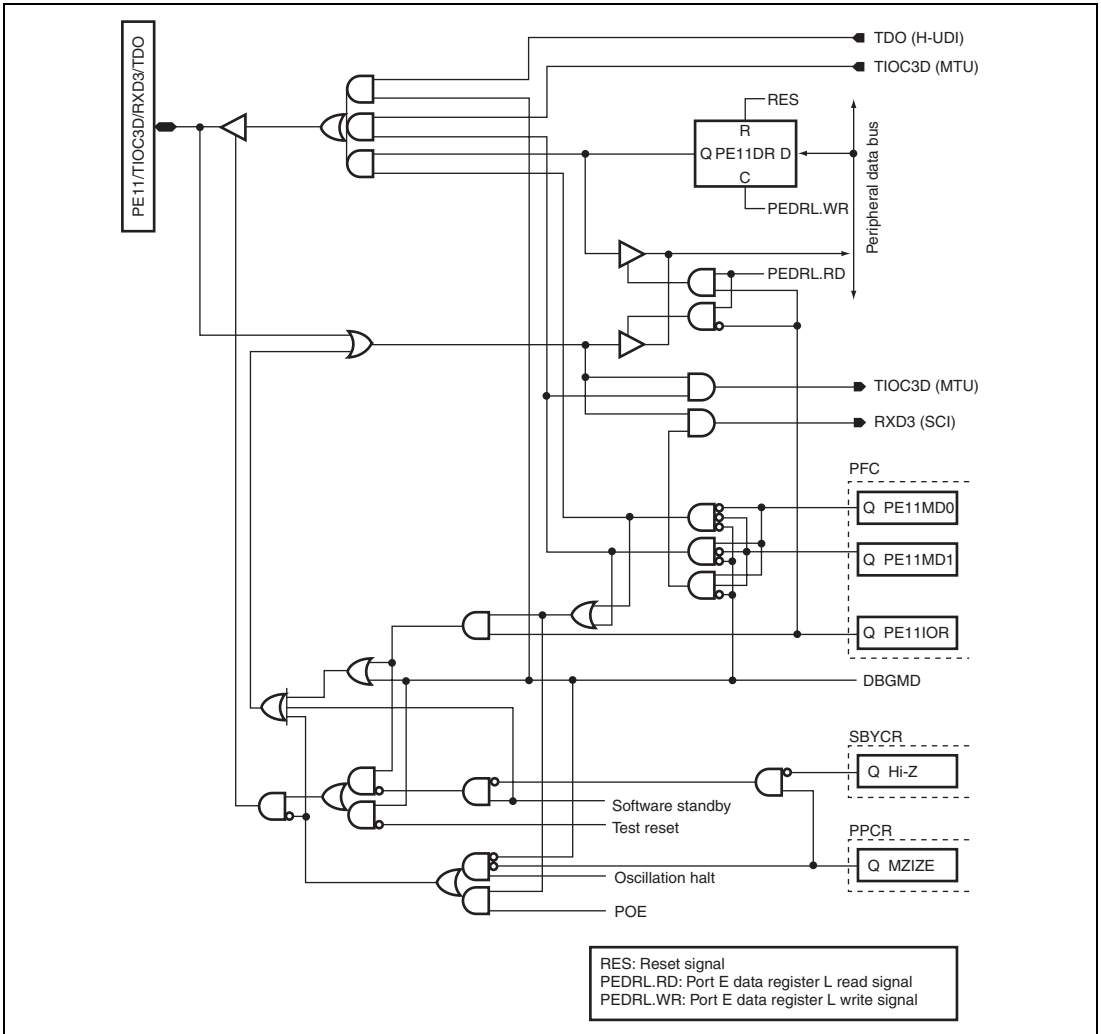

Figure D.55 PE11/TIOC3D/RXD3/TDO

Symbol in Figure D.55

Available Products

| Pins | PE11 | TIOC3D | RXD3 | TDO | Available Products | | | |
|--------------------------|------|-----------------|---------------|----------------|---|---|--------|---|
| | | | | | SH7144 | | SH7145 | |
| | | | | | Masked ROM version/ ROM less version | Masked ROM version/ ROM less version | | |
| PE11/TIOC3D/ RXD3/TDO | PE11 | TIOC3D (MTU) | RXD3 (SCI) | TDO (H-UDI) | — | — | √ | — |

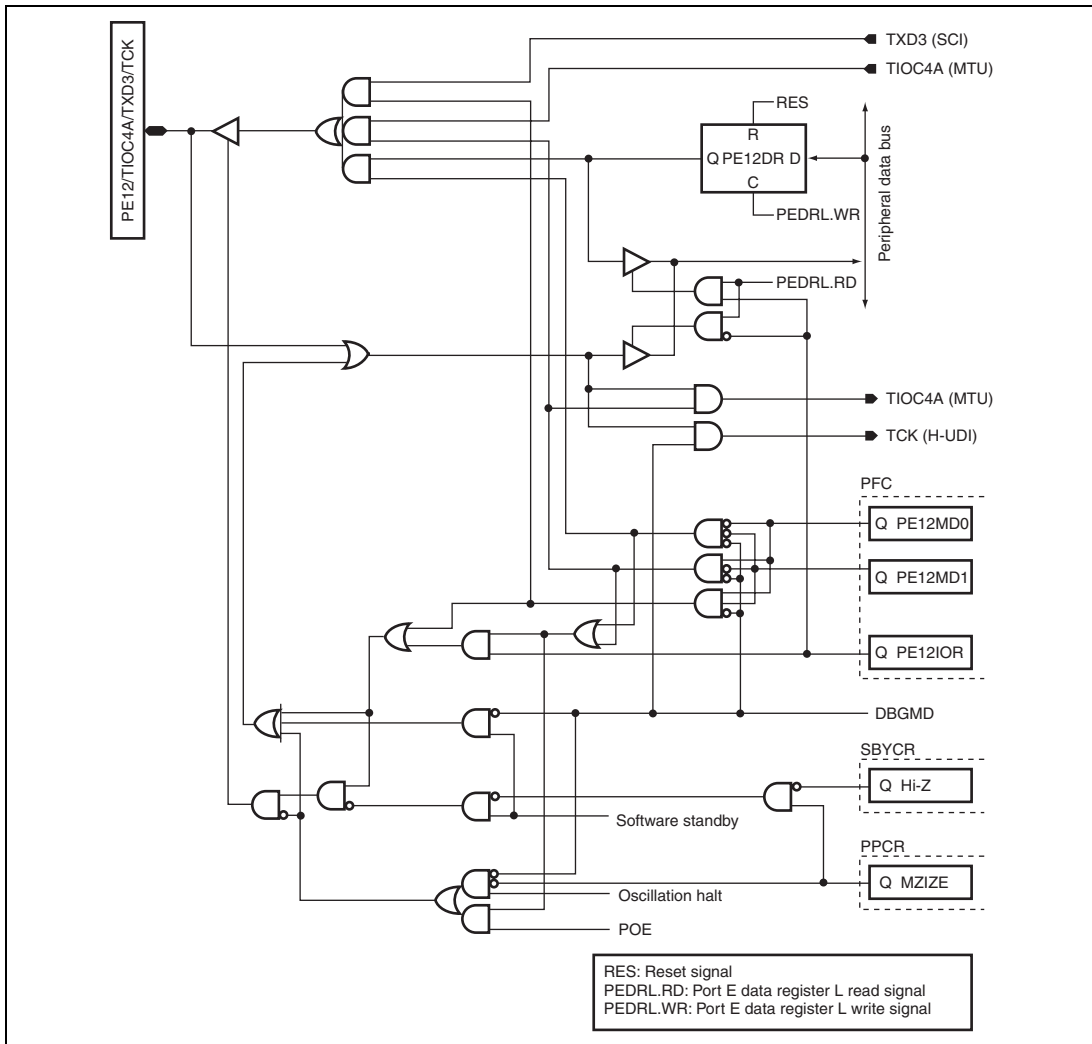

Figure D.56 PE12/TIOC4A/TXD3/TCK

Symbol in Figure D.56

Available Products

| Pins | PE12 | TIOC4A | TXD3 | TCK | Available Products | | | |
|--------------------------|------|-----------------|---------------|----------------|--------------------|---|----------------|---|
| | | | | | F-ZTAT version | SH7144 Masked ROM version/ ROM less version | F-ZTAT version | SH7145 Masked ROM version/ ROM less version |
| PE12/TIOC4A/ TXD3/TCK | PE12 | TIOC4A (MTU) | TXD3 (SCI) | TCK (H-UDI) | — | — | √ | — |

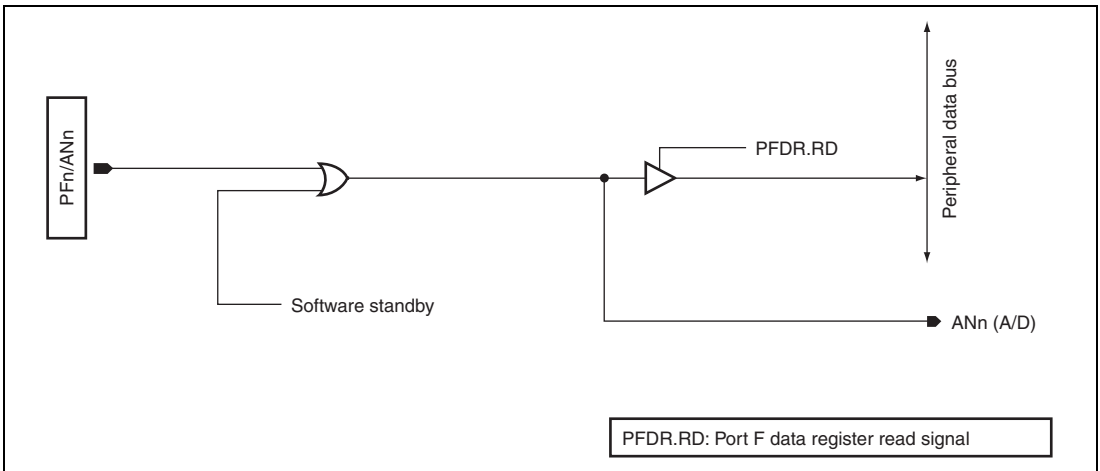

Figure D.57 PFn/ANn

Symbol in Figure D.57

Available Products

| Pins | PFn | ANn | SH7144 | | SH7145 | |
|---------|-----|-----------|----------------|---|----------------|---|
| | | | F-ZTAT version | Masked ROM version/ ROM less version | F-ZTAT version | Masked ROM version/ ROM less version |
| PF0/AN0 | PF0 | AN0 (A/D) | √ | √ | √ | √ |
| PF1/AN1 | PF1 | AN1 (A/D) | √ | √ | √ | √ |
| PF2/AN2 | PF2 | AN2 (A/D) | √ | √ | √ | √ |
| PF3/AN3 | PF3 | AN3 (A/D) | √ | √ | √ | √ |
| PF4/AN4 | PF4 | AN4 (A/D) | √ | √ | √ | √ |
| PF5/AN5 | PF5 | AN5 (A/D) | √ | √ | √ | √ |
| PF6/AN6 | PF6 | AN6 (A/D) | √ | √ | √ | √ |
| PF7/AN7 | PF7 | AN7 (A/D) | √ | √ | √ | √ |

Appendix E Package Dimensions

The package dimensions that are shown in the Renesas Semiconductor Package Data Book have priority.

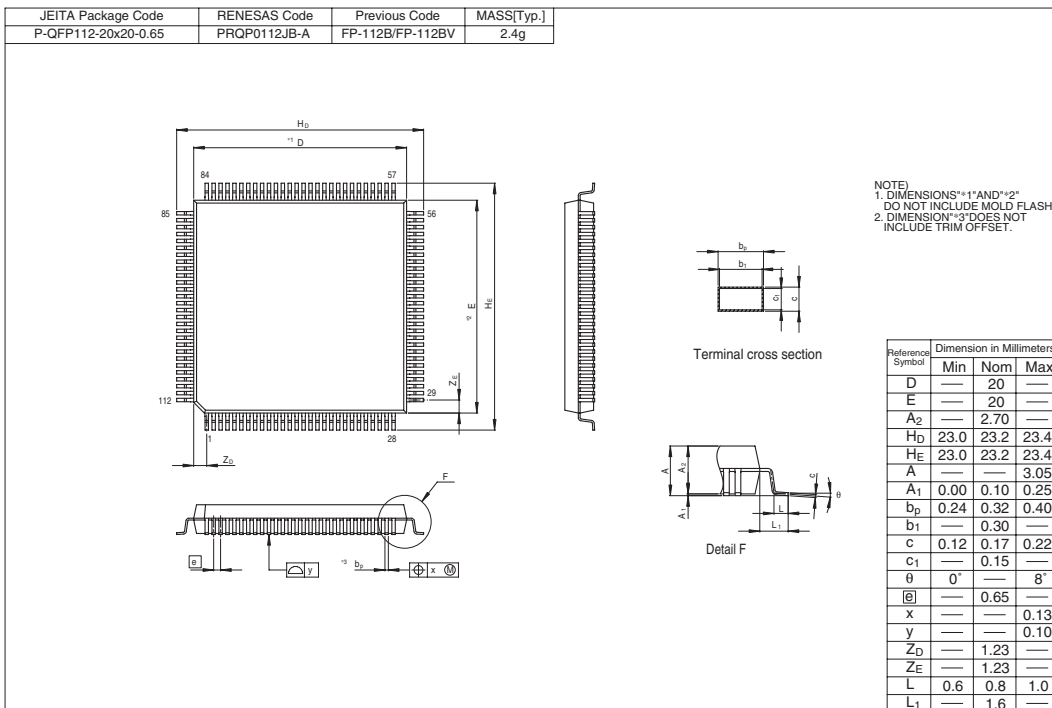
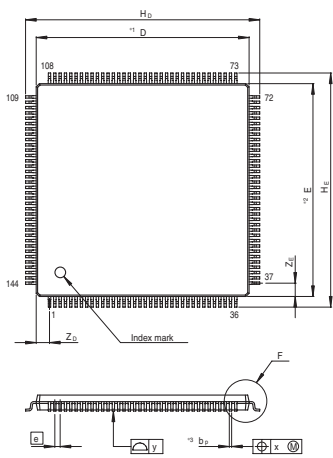
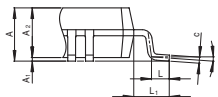

Figure E.1 FP-112B

| | | | |
|----------------------|--------------|------------------|------------|
| JEITA Package Code | RENESAS Code | Previous Code | MASS[Typ.] |
| P-LQFP144-20x20-0.50 | PLQP0144KB-A | FP-144F/FP-144FV | 1.4g |



Terminal cross section



Detail F

NOTE)
 1. DIMENSIONS *1* AND *2* DO NOT INCLUDE MOLD FLASH
 2. DIMENSION *3* DOES NOT INCLUDE TRIM OFFSET.

| Reference Symbol | Dimension in Millimeters | | |
|------------------|--------------------------|------|------|
| | Min | Nom | Max |
| D | — | 20 | — |
| E | — | 20 | — |
| A ₂ | — | 1.40 | — |
| H _D | 21.8 | 22.0 | 22.2 |
| H _E | 21.8 | 22.0 | 22.2 |
| A | — | — | 1.70 |
| A ₁ | 0.00 | 0.10 | 0.20 |
| b _p | 0.17 | 0.22 | 0.27 |
| b ₁ | — | 0.20 | — |
| c | 0.12 | 0.17 | 0.22 |
| c ₁ | — | 0.15 | — |
| θ | 0° | — | 8° |
| Ⓜ | — | 0.5 | — |
| x | — | — | 0.08 |
| y | — | — | 0.10 |
| Z _D | — | 1.25 | — |
| Z _E | — | 1.25 | — |
| L | 0.4 | 0.5 | 0.6 |
| L ₁ | — | 1.0 | — |

Figure E.2 FP-144F

Main Revisions for this Edition

Item Page Revision (See Manual for Details)

5.1.3 Exception Processing Vector Table 64 Table and note amended

Table 5.3 Exception Processing Vector Table

| Exception Sources | Vector Numbers | Vector Table Address Offset |
|-----------------------------|----------------|-----------------------------|
| On-chip peripheral module*2 | 72 | H'00000120 to H'00000123 |
| | : | : |
| | 255 | H'000003FC to H'000003FF |

Notes: 1. Only in the F-ZTAT version.
2. The vector numbers and vector table address offsets for each on-chip peripheral module interrupt are given in table 6.2.

11.4.5 PWM Modes 275 Figure amended

Figure 11.23 Example of PWM Mode Operation (3)

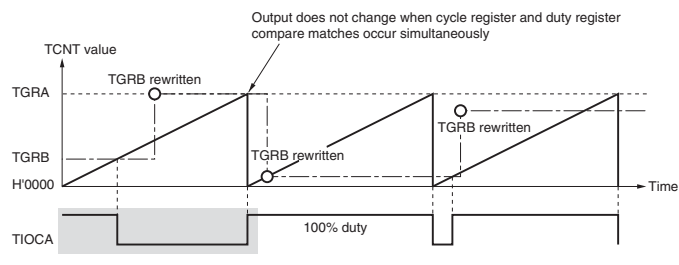

11.4.8 Complementary PWM Mode 290 Figure amended

Figure 11.34 Complementary PWM Mode Counter Operation

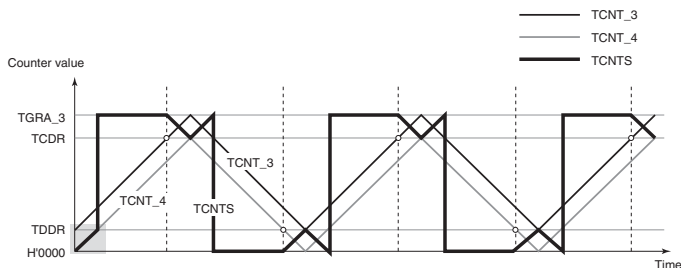

| Item | Page | Revision (See Manual for Details) |
|---|------|-----------------------------------|
| 11.7.16 Contention between Overflow/Underflow and Counter Clearing Figure 11.83 Contention between Overflow and Counter Clearing | 333 | Figure amended |
| | | |
| 11.7.17 Contention between TCNT Write and Overflow/Underflow Figure 11.84 Contention between TCNT Write and Overflow | 334 | Figure amended |
| | | |
| 11.7.22 Note on Buffer Operation Setting | 335 | Newly added |
| 12.1 Features | 379 | Description replaced |
| 13.4.4 SCI Initialization (Asynchronous Mode) Figure 13.5 Sample SCI Initialization Flowchart | 430 | Figure replaced |

| Item | Page | Revision (See Manual for Details) | | | | | | | | | | | | | | | | | | | | | | | | | | | | | | | | | | | | | | | | | | | | | | | | | | | | | | | | | | | | |
|--|---------------------|---|---------------------|---------------------|---------------------|--|--|--|---------------------|---------------------|---------------------|---------------------|---------------------|---------------------|--------|---------|---------|---------|----------|----------|--------|--------|---------|---------|---------|----------|--------|--------|---------|---------|---------|---------|--------|--------|--------|--------|---------|---------|--------|--------|--------|--------|---------|---------|--------|--------|--------|--------|--------|--------|---------|--------|--------|--------|--------|--------|---------|--------|--------|--------|--------|--------|
| 13.6.1 Clock | 443 | Description added <p>... Eight serial clock pulses are output in the transfer of one character, and when no transfer is performed, the clock is fixed high. However, during receive-only operation the synchronization clock is output until an overrun error occurs or the RE bit is cleared to 0. When receive operation in single-character units is desired, select an external clock as the clock source.</p> | | | | | | | | | | | | | | | | | | | | | | | | | | | | | | | | | | | | | | | | | | | | | | | | | | | | | | | | | | | | |
| 13.6.2 SCI Initialization (Clocked Synchronous Mode) | 444 | Figure replaced <p>Figure 13.15 Sample SCI Initialization Flowchart</p> | | | | | | | | | | | | | | | | | | | | | | | | | | | | | | | | | | | | | | | | | | | | | | | | | | | | | | | | | | | | |
| 14.3.4 I2C Bus Mode Register (ICMR) | 476 | Table and note amended <p>Table 14.3 Setting of the Transfer Rate</p> <table border="1"> <thead> <tr> <th colspan="6">Transfer Rate</th> </tr> <tr> <th>Pϕ= 10MHz</th> <th>Pϕ= 16MHz</th> <th>Pϕ= 20MHz</th> <th>Pϕ= 25MHz</th> <th>Pϕ= 33MHz</th> <th>Pϕ= 40MHz</th> </tr> </thead> <tbody> <tr> <td>357kHz</td> <td>571kHz*</td> <td>714kHz*</td> <td>893kHz*</td> <td>1.18MHz*</td> <td>1.43MHz*</td> </tr> <tr> <td>250kHz</td> <td>400kHz</td> <td>500kHz*</td> <td>625kHz*</td> <td>825kHz*</td> <td>1.00MHz*</td> </tr> <tr> <td>208kHz</td> <td>333kHz</td> <td>417kHz*</td> <td>521kHz*</td> <td>688kHz*</td> <td>833kHz*</td> </tr> <tr> <td>156kHz</td> <td>250kHz</td> <td>313kHz</td> <td>391kHz</td> <td>516kHz*</td> <td>625kHz*</td> </tr> <tr> <td>125kHz</td> <td>200kHz</td> <td>250kHz</td> <td>313kHz</td> <td>413kHz*</td> <td>500kHz*</td> </tr> <tr> <td>100kHz</td> <td>160kHz</td> <td>200kHz</td> <td>250kHz</td> <td>330kHz</td> <td>400kHz</td> </tr> <tr> <td>89.3kHz</td> <td>143kHz</td> <td>179kHz</td> <td>223kHz</td> <td>295kHz</td> <td>357kHz</td> </tr> <tr> <td>78.1kHz</td> <td>125kHz</td> <td>156kHz</td> <td>195kHz</td> <td>258kHz</td> <td>313kHz</td> </tr> </tbody> </table> <p>Note: * Out of the I²C bus interface specification (Normal mode: maximum 100 kHz, High speed mode: maximum 400 kHz) Due to factors such as load conditions, it may not be possible to obtain the designated transfer rate when the value of IICX is 0 and the peripheral clock ϕ frequency exceeds 16 MHz. Set IICX to 1 when Pϕ is greater than 16 MHz.</p> | Transfer Rate | | | | | | P ϕ = 10MHz | P ϕ = 16MHz | P ϕ = 20MHz | P ϕ = 25MHz | P ϕ = 33MHz | P ϕ = 40MHz | 357kHz | 571kHz* | 714kHz* | 893kHz* | 1.18MHz* | 1.43MHz* | 250kHz | 400kHz | 500kHz* | 625kHz* | 825kHz* | 1.00MHz* | 208kHz | 333kHz | 417kHz* | 521kHz* | 688kHz* | 833kHz* | 156kHz | 250kHz | 313kHz | 391kHz | 516kHz* | 625kHz* | 125kHz | 200kHz | 250kHz | 313kHz | 413kHz* | 500kHz* | 100kHz | 160kHz | 200kHz | 250kHz | 330kHz | 400kHz | 89.3kHz | 143kHz | 179kHz | 223kHz | 295kHz | 357kHz | 78.1kHz | 125kHz | 156kHz | 195kHz | 258kHz | 313kHz |
| Transfer Rate | | | | | | | | | | | | | | | | | | | | | | | | | | | | | | | | | | | | | | | | | | | | | | | | | | | | | | | | | | | | | | |
| P ϕ = 10MHz | P ϕ = 16MHz | P ϕ = 20MHz | P ϕ = 25MHz | P ϕ = 33MHz | P ϕ = 40MHz | | | | | | | | | | | | | | | | | | | | | | | | | | | | | | | | | | | | | | | | | | | | | | | | | | | | | | | | | |
| 357kHz | 571kHz* | 714kHz* | 893kHz* | 1.18MHz* | 1.43MHz* | | | | | | | | | | | | | | | | | | | | | | | | | | | | | | | | | | | | | | | | | | | | | | | | | | | | | | | | | |
| 250kHz | 400kHz | 500kHz* | 625kHz* | 825kHz* | 1.00MHz* | | | | | | | | | | | | | | | | | | | | | | | | | | | | | | | | | | | | | | | | | | | | | | | | | | | | | | | | | |
| 208kHz | 333kHz | 417kHz* | 521kHz* | 688kHz* | 833kHz* | | | | | | | | | | | | | | | | | | | | | | | | | | | | | | | | | | | | | | | | | | | | | | | | | | | | | | | | | |
| 156kHz | 250kHz | 313kHz | 391kHz | 516kHz* | 625kHz* | | | | | | | | | | | | | | | | | | | | | | | | | | | | | | | | | | | | | | | | | | | | | | | | | | | | | | | | | |
| 125kHz | 200kHz | 250kHz | 313kHz | 413kHz* | 500kHz* | | | | | | | | | | | | | | | | | | | | | | | | | | | | | | | | | | | | | | | | | | | | | | | | | | | | | | | | | |
| 100kHz | 160kHz | 200kHz | 250kHz | 330kHz | 400kHz | | | | | | | | | | | | | | | | | | | | | | | | | | | | | | | | | | | | | | | | | | | | | | | | | | | | | | | | | |
| 89.3kHz | 143kHz | 179kHz | 223kHz | 295kHz | 357kHz | | | | | | | | | | | | | | | | | | | | | | | | | | | | | | | | | | | | | | | | | | | | | | | | | | | | | | | | | |
| 78.1kHz | 125kHz | 156kHz | 195kHz | 258kHz | 313kHz | | | | | | | | | | | | | | | | | | | | | | | | | | | | | | | | | | | | | | | | | | | | | | | | | | | | | | | | | |
| 14.5 Usage Notes | 535, | Description added | | | | | | | | | | | | | | | | | | | | | | | | | | | | | | | | | | | | | | | | | | | | | | | | | | | | | | | | | | | | |
| 10. Notes on WAIT function | 536 | | | | | | | | | | | | | | | | | | | | | | | | | | | | | | | | | | | | | | | | | | | | | | | | | | | | | | | | | | | | | |

| Item | Page | Revision (See Manual for Details) | | | | | | | | | | |
|--|------------|---|--------|---|---------------|-----|-------------|---|-----|---|--------|---|
| 15.3.2 A/D Control/Status Register_0, 1 (ADCSR_0, ADCSR_1) | 545 | Table amended | | | | | | | | | | |
| | | <table border="1"> <thead> <tr> <th>Bit</th> <th>Bit Name</th> <th>Initial Value</th> <th>R/W</th> <th>Description</th> </tr> </thead> <tbody> <tr> <td>7</td> <td>ADF</td> <td>0</td> <td>R/(W)*</td> <td> <p>A/D End Flag</p> <p>A status flag that indicates the end of A/D conversion. [Setting conditions]</p> <ul style="list-style-type: none"> When A/D conversion ends in single mode When A/D conversion ends on all specified channels in scan mode <p>[Clearing conditions]</p> <ul style="list-style-type: none"> When 0 is written after reading ADF = 1 When the DMAC or the DTC is activated by an ADI interrupt and data is read from ADDR while the DTMR bit in the DTC is cleared to 0 </td> </tr> </tbody> </table> | Bit | Bit Name | Initial Value | R/W | Description | 7 | ADF | 0 | R/(W)* | <p>A/D End Flag</p> <p>A status flag that indicates the end of A/D conversion. [Setting conditions]</p> <ul style="list-style-type: none"> When A/D conversion ends in single mode When A/D conversion ends on all specified channels in scan mode <p>[Clearing conditions]</p> <ul style="list-style-type: none"> When 0 is written after reading ADF = 1 When the DMAC or the DTC is activated by an ADI interrupt and data is read from ADDR while the DTMR bit in the DTC is cleared to 0 |
| Bit | Bit Name | Initial Value | R/W | Description | | | | | | | | |
| 7 | ADF | 0 | R/(W)* | <p>A/D End Flag</p> <p>A status flag that indicates the end of A/D conversion. [Setting conditions]</p> <ul style="list-style-type: none"> When A/D conversion ends in single mode When A/D conversion ends on all specified channels in scan mode <p>[Clearing conditions]</p> <ul style="list-style-type: none"> When 0 is written after reading ADF = 1 When the DMAC or the DTC is activated by an ADI interrupt and data is read from ADDR while the DTMR bit in the DTC is cleared to 0 | | | | | | | | |
| 16.2.2 Compare Match Timer Control/Status Register_0, 1 (CMCSR_0, CMCSR_1) | 561 | Table amended | | | | | | | | | | |
| | | <table border="1"> <thead> <tr> <th>Bit</th> <th>Bit Name</th> <th>Initial Value</th> <th>R/W</th> <th>Description</th> </tr> </thead> <tbody> <tr> <td>7</td> <td>CMF</td> <td>0</td> <td>R/(W)*</td> <td> <p>Compare Match Flag</p> <p>This flag indicates whether or not the CMCNT and CMCOR values have matched.</p> <p>0: CMCNT and CMCOR values have not matched 1: CMCNT and CMCOR values have matched</p> <p>[Clearing condition]</p> <ul style="list-style-type: none"> Write 0 to CMF after reading 1 from it When the DTC is activated by an CMI interrupt and data is transferred with the DISEL bit in DTMR of DTC = 0 </td> </tr> </tbody> </table> | Bit | Bit Name | Initial Value | R/W | Description | 7 | CMF | 0 | R/(W)* | <p>Compare Match Flag</p> <p>This flag indicates whether or not the CMCNT and CMCOR values have matched.</p> <p>0: CMCNT and CMCOR values have not matched 1: CMCNT and CMCOR values have matched</p> <p>[Clearing condition]</p> <ul style="list-style-type: none"> Write 0 to CMF after reading 1 from it When the DTC is activated by an CMI interrupt and data is transferred with the DISEL bit in DTMR of DTC = 0 |
| Bit | Bit Name | Initial Value | R/W | Description | | | | | | | | |
| 7 | CMF | 0 | R/(W)* | <p>Compare Match Flag</p> <p>This flag indicates whether or not the CMCNT and CMCOR values have matched.</p> <p>0: CMCNT and CMCOR values have not matched 1: CMCNT and CMCOR values have matched</p> <p>[Clearing condition]</p> <ul style="list-style-type: none"> Write 0 to CMF after reading 1 from it When the DTC is activated by an CMI interrupt and data is transferred with the DISEL bit in DTMR of DTC = 0 | | | | | | | | |
| 19.1 Features | 657 | Description amended | | | | | | | | | | |
| | | <ul style="list-style-type: none"> Reprogramming capability <p>See section 26.5, Flash Memory Characteristics.</p> | | | | | | | | | | |
| 19.8.3 Interrupt Handling when Programming/Erasing Flash Memory | 679 | Figure amended | | | | | | | | | | |
| Figure 19.10 Erase/Eraser-Verify Flowchart | | <pre> graph TD A([Erase start *1]) --> B[SWE bit ← 1] B --> C[Wait (tSSWE) us] C --> D[n ← 1] D --> E[Set EBR1 and EBR2 *3] E --> D </pre> | | | | | | | | | | |
| 19.11.3 Notes on Flash Memory Programming and Erasing | 683 to 685 | Description replaced | | | | | | | | | | |
| 23.5.7 Settings of AUD-Related Pins when Using E10A | 717 | Newly added | | | | | | | | | | |

| Item | Page | Revision (See Manual for Details) | | | | | | | | | | | | | | | | | | | | | | | | | | | | |
|---|--------------------------|--|-----------------------------|--------|------|------------------------|------|------------------------------------|------------------------|-------------------------------|-----------------------------|--------------|--------------------------------|---|---|-----------------------------|-----|------------------------------------|---|---|-----------------------------|-----|--|--|-----------------|-----|---|---|---|--|
| 24.3.1 Sleep Mode Transition to Sleep Mode | 727 | In sleep mode, data should not be accessed by the DMAC, DTC, or AUD. | | | | | | | | | | | | | | | | | | | | | | | | | | | | |
| Clearing Sleep Mode | — | Description deleted | | | | | | | | | | | | | | | | | | | | | | | | | | | | |
| <ul style="list-style-type: none"> Clearing by the interrupt (masked version and ROM less version) Clearing by the DMAC/DTC address error (masked version and ROM less version) | | | | | | | | | | | | | | | | | | | | | | | | | | | | | | |
| 24.4.5 DMAC, DTC, or AUD Operation in Sleep Mode | 731 | Description amended In sleep mode, data should not be accessed by the DMAC, DTC, or AUD. | | | | | | | | | | | | | | | | | | | | | | | | | | | | |
| 26.2 DC Characteristics | 768 | Table amended | | | | | | | | | | | | | | | | | | | | | | | | | | | | |
| Table 26.2 DC Characteristics | | <table border="1"> <thead> <tr> <th>Item</th> <th>Symbol</th> <th>Min.</th> <th>Typ.</th> <th>Max.</th> <th>Unit</th> <th>Measurement Conditions</th> </tr> </thead> <tbody> <tr> <td>Schmitt trigger input voltage</td> <td>V_{T+} (V_{T+})</td> <td>$V_{CC}-0.5$</td> <td>—</td> <td>—</td> <td>V</td> <td></td> </tr> <tr> <td></td> <td>V_{T-} (V_{T-})</td> <td>—</td> <td>—</td> <td>0.5</td> <td>V</td> <td></td> </tr> <tr> <td></td> <td>$V_{T+}-V_{T-}$</td> <td>0.2</td> <td>—</td> <td>—</td> <td>V</td> <td></td> </tr> </tbody> </table> | Item | Symbol | Min. | Typ. | Max. | Unit | Measurement Conditions | Schmitt trigger input voltage | V_{T+} (V_{T+}) | $V_{CC}-0.5$ | — | — | V | | | V_{T-} (V_{T-}) | — | — | 0.5 | V | | | $V_{T+}-V_{T-}$ | 0.2 | — | — | V | |
| Item | Symbol | Min. | Typ. | Max. | Unit | Measurement Conditions | | | | | | | | | | | | | | | | | | | | | | | | |
| Schmitt trigger input voltage | V_{T+} (V_{T+}) | $V_{CC}-0.5$ | — | — | V | | | | | | | | | | | | | | | | | | | | | | | | | |
| | V_{T-} (V_{T-}) | — | — | 0.5 | V | | | | | | | | | | | | | | | | | | | | | | | | | |
| | $V_{T+}-V_{T-}$ | 0.2 | — | — | V | | | | | | | | | | | | | | | | | | | | | | | | | |
| 26.4 A/D Converter Characteristics | 795 | Table amended | | | | | | | | | | | | | | | | | | | | | | | | | | | | |
| Table 26.17 A/D Converter Characteristics | | <table border="1"> <thead> <tr> <th>Item</th> <th>Min.</th> <th>Typ.</th> <th>Max.</th> <th>Unit</th> </tr> </thead> <tbody> <tr> <td>Non-linear error (reference value)</td> <td>—</td> <td>—</td> <td>$\pm 3.0^{*3}/\pm 5.0^{*6}$</td> <td>LSB</td> </tr> <tr> <td>Offset error (reference value)</td> <td>—</td> <td>—</td> <td>$\pm 3.0^{*3}/\pm 5.0^{*6}$</td> <td>LSB</td> </tr> <tr> <td>Full-scale error (reference value)</td> <td>—</td> <td>—</td> <td>$\pm 3.0^{*3}/\pm 5.0^{*6}$</td> <td>LSB</td> </tr> </tbody> </table> | Item | Min. | Typ. | Max. | Unit | Non-linear error (reference value) | — | — | $\pm 3.0^{*3}/\pm 5.0^{*6}$ | LSB | Offset error (reference value) | — | — | $\pm 3.0^{*3}/\pm 5.0^{*6}$ | LSB | Full-scale error (reference value) | — | — | $\pm 3.0^{*3}/\pm 5.0^{*6}$ | LSB | | | | | | | | |
| Item | Min. | Typ. | Max. | Unit | | | | | | | | | | | | | | | | | | | | | | | | | | |
| Non-linear error (reference value) | — | — | $\pm 3.0^{*3}/\pm 5.0^{*6}$ | LSB | | | | | | | | | | | | | | | | | | | | | | | | | | |
| Offset error (reference value) | — | — | $\pm 3.0^{*3}/\pm 5.0^{*6}$ | LSB | | | | | | | | | | | | | | | | | | | | | | | | | | |
| Full-scale error (reference value) | — | — | $\pm 3.0^{*3}/\pm 5.0^{*6}$ | LSB | | | | | | | | | | | | | | | | | | | | | | | | | | |
| 26.5 Flash Memory Characteristics | 796, 797 | Table replaced | | | | | | | | | | | | | | | | | | | | | | | | | | | | |
| Table 26.18 Flash Memory Characteristics | | | | | | | | | | | | | | | | | | | | | | | | | | | | | | |
| Appendix E Package Dimensions | 870 | Figure replaced | | | | | | | | | | | | | | | | | | | | | | | | | | | | |
| Figure E.1 FP-112B | | | | | | | | | | | | | | | | | | | | | | | | | | | | | | |
| Figure E.2 FP-144F | 871 | | | | | | | | | | | | | | | | | | | | | | | | | | | | | |

Index

| | | | |
|--|---------|---|--------|
| A/D conversion time | 550 | Data transfer controller (DTC)..... | 113 |
| A/D converter | 541 | Delayed branch instructions | 21 |
| Absolute maximum ratings | 767 | Direct memory access controller (DMAC) | |
| Activation by interrupt..... | 134 | | 167 |
| Activation by software..... | 134 | DTC vector addresses | 124 |
| Address error exception processing | 68 | Dual address mode | 190 |
| Address map | 51, 141 | Effective address | 25 |
| Addressing modes..... | 25 | Electrical characteristics..... | 767 |
| Advanced user debugger (AUD) | 705 | Error Protection..... | 681 |
| Asynchronous serial communication | 426 | Exception processing | 61 |
| Auto-request mode..... | 182 | Exception processing state | 46 |
| Block configuration | 663 | Exception processing vector table..... | 63 |
| Block transfer mode..... | 129 | External clock input | 56 |
| Boot mode..... | 671 | External request mode..... | 182 |
| Branch trace mode | 708 | Fixed mode..... | 184 |
| Buffer operation..... | 266 | Flash memory..... | 657 |
| Burst mode..... | 195 | Flash memory emulation in RAM..... | 674 |
| Bus arbitration | 161 | Free-running counters | 260 |
| Bus masters..... | 161 | Function for detecting the oscillator halt...57 | |
| Bus release state..... | 46 | Functions of multiplexed pins..... | 569 |
| Bus state controller (BSC)..... | 137 | General illegal instructions | 72 |
| Byte data | 19 | General registers (Rn) | 15 |
| Cascaded operation | 269 | Global base register (GBR)..... | 18 |
| Chain transfer..... | 130 | Hardware protection..... | 680 |
| Clock mode..... | 48 | I/O ports | 633 |
| Clock pulse generator | 53 | I ² C bus format | 493 |
| Clocked synchronous communication | 443 | I ² C bus interface..... | 467 |
| Compare match..... | 261 | Illegal slot instructions | 72 |
| Compare match timer (CMT) | 559 | Immediate data format | 20 |
| Complementary PWM mode | 285 | Input capture function | 263 |
| Continuous scan mode..... | 549 | Internal clock | 53 |
| Control registers..... | 17 | Interrupt controller (INTC) | 77 |
| CPU | 15 | Interrupt exception processing | 70 |
| Crystal oscillator | 55 | Interrupt response time..... | 96 |
| Cycle-steal mode | 195 | Interval timer mode | 386 |
| Data format in registers..... | 19 | IRQ interrupts | 84, 87 |
| Data formats..... | 19 | Longword data | 19 |
| Data formats in memory | 19 | Manual reset..... | 66 |

| | | | |
|---|--------------------|--------------|-------------------------|
| Mask ROM | 689 | CHCR..... | 172, 742, 754, 763 |
| Master device..... | 496 | CMCNT | 562, 740, 752, 762 |
| MCU operating modes..... | 47 | CMCOR | 562, 740, 752, 762 |
| Module standby mode..... | 730 | CMCSR..... | 561, 740, 752, 762 |
| Multi-function timer pulse unit (MTU) .. | 213 | CMSTR..... | 560, 740, 752, 762 |
| Multiply-and-accumulate registers | | DAR..... | 171, 742, 754, 763 |
| (MAC) | 18 | DMAOR..... | 178, 742, 754, 763 |
| Multiprocessor communication function | 437 | DMATCR | 171, 742, 754, 763 |
| NMI interrupts | 87 | DTBR..... | 121, 743, 756, 764 |
| Normal mode | 127 | DTCRA..... | 118 |
| On-board programming modes | 670 | DTCRB | 119 |
| On-chip peripheral module interrupts..... | 88 | DTCSR..... | 120, 743, 756, 764 |
| On-chip peripheral module request | | DTDAR..... | 118 |
| mode | 183 | DTER | 119, 743, 756, 764 |
| Permissible signal source impedance..... | 558 | DTIAR | 118 |
| Phase counting mode | 276 | DTMR..... | 116 |
| Pin function controller (PFC) | 569 | DTSAR | 118 |
| Pin functions in each operating mode..... | 569 | EBR1..... | 667, 741, 753, 763 |
| Port output enable (POE)..... | 368 | EBR2..... | 668, 741, 753, 763 |
| Power-down modes | 719 | FLMCR1 | 665, 741, 753, 763 |
| Power-down state..... | 46 | FLMCR2 | 666, 741, 753, 763 |
| Power-on reset | 65 | ICCR | 477, 744, 757, 764 |
| Procedure register (PR)..... | 18 | ICDR..... | 471, 744, 757, 764 |
| Processing states | 45 | ICMR | 474, 744, 757, 764 |
| Program counter (PC)..... | 18 | ICR1..... | 80, 738, 749, 761 |
| Program execution state..... | 46 | ICR2..... | 82, 738, 749, 761 |
| PWM mode..... | 271 | ICSR..... | 486, 744, 757 |
| RAM | 691 | ICSR1..... | 370, 377, 739, 751, 762 |
| RAM emulation | 674 | IPR | 85, 738, 749, 761 |
| RAM monitor mode..... | 709 | ISR | 84, 738, 749, 761 |
| Reading from TCNT, TCSR, and RSTCSR | | MSTCR..... | 725, 741, 753, 763 |
| | 390 | OCSR | 374, 739, 751, 762 |
| Register | | PACR | 597, 738, 750, 761 |
| ADCR | 547, 740, 753, 763 | PADR..... | 636, 738, 750, 761 |
| ADCSR..... | 545, 740, 752, 762 | PAIOR | 596, 738, 750, 761 |
| ADDR..... | 544, 740, 752, 762 | PBCR | 605, 738, 750, 761 |
| ADTSR..... | 548, 743, 756, 764 | PBDR..... | 640, 738, 750, 761 |
| BCR1 | 144, 742, 754, 763 | PBIOR..... | 605, 738, 750, 761 |
| BCR2 | 147, 742, 754, 763 | PCCR | 609, 738, 750, 761 |
| BRR | 416, 734, 745, 758 | PCDR..... | 643, 738, 750, 761 |

| | | | |
|------------------|-------------------------|--|--------------------|
| PCIOR | 609, 738, 750, 761 | TGRC | 249 |
| PDCR..... | 612, 739, 751, 762 | TGRD..... | 249 |
| PDDR..... | 647, 739, 751, 762 | TIER..... | 244, 735, 746, 759 |
| PDIOR | 611, 739, 751, 762 | TIOR | 226, 735, 746, 759 |
| PECR | 622, 739, 751, 762 | TMDR..... | 224, 735, 746, 759 |
| PEDRL..... | 652, 739, 751, 762 | TOCR..... | 253, 735, 746, 759 |
| PEIORL | 621, 739, 751, 762 | TOER | 252, 735, 746, 759 |
| PFDR | 654, 739, 751, 762 | TSR (MTU)..... | 246, 736, 747, 759 |
| PPCR | 630, 743, 756, 764 | TSR (SCI) | 398 |
| RAMER..... | 153, 668, 742, 754, 763 | TSTR..... | 250, 736, 747, 759 |
| RDR..... | 398, 734, 745, 758 | TSYR | 250, 736, 747, 759 |
| RSR..... | 398 | UBAMR..... | 103, 741, 753, 763 |
| RSTCSR | 384, 741, 753, 763 | UBAR | 103, 741, 753, 763 |
| SAR (DMAC)..... | 170, 742, 754, 763 | UBBR..... | 104, 741, 753, 763 |
| SAR (IIC)..... | 472, 744, 757, 764 | UBCR..... | 105, 741, 753, 763 |
| SARX..... | 473, 744, 757, 764 | WCR1 | 152, 742, 754, 763 |
| SBYCR | 722, 741, 753, 763 | WCR2 | 153, 742, 754, 763 |
| SCR..... | 402, 734, 745, 758 | Register address table..... | 733 |
| SCRX..... | 490, 743, 756, 764 | Register bit list | 745 |
| SDBPR..... | 699 | Register states in each operating mode ... | 758 |
| SDCR..... | 415, 734, 745, 758 | Repeat mode..... | 127 |
| SDDR..... | 699, 744, 757, 764 | Reset state | 46 |
| SDIR | 697, 744, 757, 764 | Reset-synchronized PWM mode..... | 282 |
| SDSR | 698, 744, 757, 764 | RISC-type | 21 |
| SMR..... | 399, 734, 745, 758 | Round robin mode..... | 184 |
| SSR..... | 407, 734, 745, 758 | Serial communication interface (SCI)..... | 393 |
| SYSCR..... | 724, 741, 753, 763 | Serial format..... | 493 |
| TCBR..... | 257, 736, 746, 759 | Single address mode..... | 188 |
| TCDR..... | 257, 735, 746, 759 | Single mode | 549 |
| TCNT (MTU) | 249, 735, 746, 760 | Single-cycle scan mode..... | 550 |
| TCNT (WDT) | 381, 741, 753, 763 | Slave device | 509 |
| TCNTS..... | 257, 736, 746, 759 | Sleep mode..... | 727 |
| TCR | 220, 735, 746, 759 | Smart card interface | 451 |
| TCSR | 382, 741, 753, 763 | Software protection | 681 |
| TDDR | 257, 735, 746, 759 | Software standby mode..... | 728 |
| TDR | 398, 734, 745, 758 | Status register (SR) | 17 |
| TGCR..... | 255, 735, 746, 759 | Synchronous operation..... | 264 |
| TGR | 735, 746, 759 | System clock (ϕ) | 53 |
| TGRA | 249 | System registers | 18 |
| TGRB..... | 249 | Trap instructions | 71 |

| | | | |
|---|-----|-------------------------------|-----|
| User break controller (UBC)..... | 101 | Vectors table | 90 |
| User break interrupt | 88 | Watchdog timer..... | 379 |
| User debugging interface (H-UDI) | 693 | Watchdog timer mode..... | 385 |
| User debugging interface (H-UDI) interrupt | 89 | Word data..... | 19 |
| User program mode | 673 | Writing to RSTCSR | 389 |
| Vector base register (VBR)..... | 18 | Writing to TCNT and TCSR..... | 389 |
| Vector No. | 90 | | |

**Renesas 32-Bit RISC Microcomputer
Hardware Manual
SH7144 Group, SH7145 Group**

Publication Date: 1st Edition, January, 2002
Rev.4.00, March 27, 2008

Published by: Sales Strategic Planning Div.
Renesas Technology Corp.

Edited by: Customer Support Department
Global Strategic Communication Div.
Renesas Solutions Corp.

Renesas Technology Corp. Sales Strategic Planning Div. Nippon Bldg., 2-6-2, Ohte-machi, Chiyoda-ku, Tokyo 100-0004, Japan



RENESAS SALES OFFICES

<http://www.renesas.com>

Refer to "<http://www.renesas.com/en/network>" for the latest and detailed information.

Renesas Technology America, Inc.

450 Holger Way, San Jose, CA 95134-1368, U.S.A
Tel: <1> (408) 382-7500, Fax: <1> (408) 382-7501

Renesas Technology Europe Limited

Dukes Meadow, Millboard Road, Bourne End, Buckinghamshire, SL8 5FH, U.K.
Tel: <44> (1628) 585-100, Fax: <44> (1628) 585-900

Renesas Technology (Shanghai) Co., Ltd.

Unit 204, 205, AZIA Center, No.1233 Lujiazui Ring Rd, Pudong District, Shanghai, China 200120
Tel: <86> (21) 5877-1818, Fax: <86> (21) 6887-7858/7898

Renesas Technology Hong Kong Ltd.

7th Floor, North Tower, World Finance Centre, Harbour City, Canton Road, Tsimshatsui, Kowloon, Hong Kong
Tel: <852> 2265-6688, Fax: <852> 2377-3473

Renesas Technology Taiwan Co., Ltd.

10th Floor, No.99, Fushing North Road, Taipei, Taiwan
Tel: <886> (2) 2715-2888, Fax: <886> (2) 3518-3399

Renesas Technology Singapore Pte. Ltd.

1 Harbour Front Avenue, #06-10, Keppel Bay Tower, Singapore 098632
Tel: <65> 6213-0200, Fax: <65> 6278-8001

Renesas Technology Korea Co., Ltd.

Kukje Center Bldg. 18th Fl., 191, 2-ka, Hangang-ro, Yongsan-ku, Seoul 140-702, Korea
Tel: <82> (2) 796-3115, Fax: <82> (2) 796-2145

Renesas Technology Malaysia Sdn. Bhd

Unit 906, Block B, Menara Amcorp, Amcorp Trade Centre, No.18, Jln Persiaran Barat, 46050 Petaling Jaya, Selangor Darul Ehsan, Malaysia
Tel: <603> 7955-9390, Fax: <603> 7955-9510



SH7144 Group, SH7145 Group Hardware Manual



Renesas Technology Corp.
2-6-2, Ote-machi, Chiyoda-ku, Tokyo, 100-0004, Japan