

General Description

The FS8855 is a low-dropout linear regulator that operations in the input voltage range from +2.5V to +9.0V and delivers 500mA output current.

The high-accuracy output voltage is preset at an internally trimmed voltage 2.5V or 3.3V. Other output voltages can be mask-optioned from 1.3V to 4.5V with 100mV increment, except FS8855-29Cx which has 2.85V output voltage.

The FS8855 consists of a 1.25V bandgap reference, an error amplifier, and a P-channel pass transistor. Other features include short-circuit protection and thermal shutdown protection. The FS8855 devices are available in TO-92, SOT-89 and SOT-223 packages.

Features

- Low dropout voltage 650mV at 500mA (Typ.)
- Up to $\pm 35\text{mV}$ output voltage accuracy ($V_{IN} \leq 7\text{V}$)
Preset at 2.5V, 3.3V
Mask options from 1.3V to 4.5V
- Small output capacitor
- Output current limit
- Thermal overload shutdown protection
- TO-92, SOT-89 and SOT-223 Package

Applications

- CD-ROM Drivers
- DVD-ROM Drivers
- Portable Consumer Equipment
- Radio Control Systems
- Wireless Communication Systems

Ordering Information

FS8855-xx x x

Package

Pin Out

D : TO-92	1.IN	2.GND	3.OUT
E : TO-92	1.GND	2.IN	3.OUT
F : TO-92	1.OUT	2.GND	3.IN
W : TO-92	1.GND	2.OUT	3.IN
G : SOT-223	1.IN	2.GND	3.OUT
H : SOT-223	1.GND	2.IN	3.OUT
J : SOT-223	1.GND	2.OUT	3.IN
X : SOT-223	1.OUT	2.GND	3.IN
K : SOT-89	1.IN	2.GND	3.OUT
L : SOT-89	1.GND	2.IN	3.OUT
I : SOT-89	1.OUT	2.GND	3.IN
Y : SOT-89	1.GND	2.OUT	3.IN

Temperature Range

C : Commercial Standard

P : Commercial Standard, Lead(Pb) Free and Phosphorous(P) Free Package

Output Voltage

13 : 1.3V	26 : 2.6V	39 : 3.9V
14 : 1.4V	27 : 2.7V	40 : 4.0V
15 : 1.5V	28 : 2.8V	41 : 4.1V
16 : 1.6V	29 : 2.85V	42 : 4.2V
17 : 1.7V	30 : 3.0V	43 : 4.3V
18 : 1.8V	31 : 3.1V	44 : 4.4V
19 : 1.9V	32 : 3.2V	45 : 4.5V
20 : 2.0V	33 : 3.3V	
21 : 2.1V	34 : 3.4V	
22 : 2.2V	35 : 3.5V	
23 : 2.3V	36 : 3.6V	
24 : 2.4V	37 : 3.7V	
25 : 2.5V	38 : 3.8V	

Note : Mask option output types are available by order only

Pin Configurations

Part No.	Pin 1	Pin 2	Pin 3
FS8855-xxxD	IN	GND	OUT
FS8855-xxxE	GND	IN	OUT
FS8855-xxxF	OUT	GND	IN
FS8855-xxxW	GND	OUT	IN

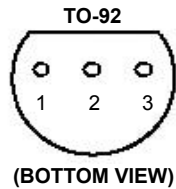

Part No.	Pin 1	Pin 2	Pin 3
FS8855-xxxK	IN	GND	OUT
FS8855-xxxL	GND	IN	OUT
FS8855-xxxI	OUT	GND	IN
FS8855-xxxY	GND	OUT	IN

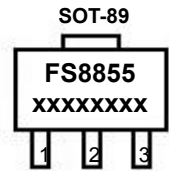

Part No.	Pin 1	Pin 2	Pin 3
FS8855-xxxG	IN	GND	OUT
FS8855-xxxH	GND	IN	OUT
FS8855-xxxJ	GND	OUT	IN
FS8855-xxxX	OUT	GND	IN

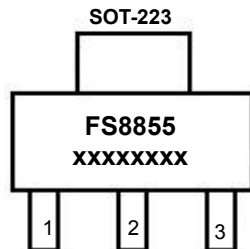

Package Marking Information

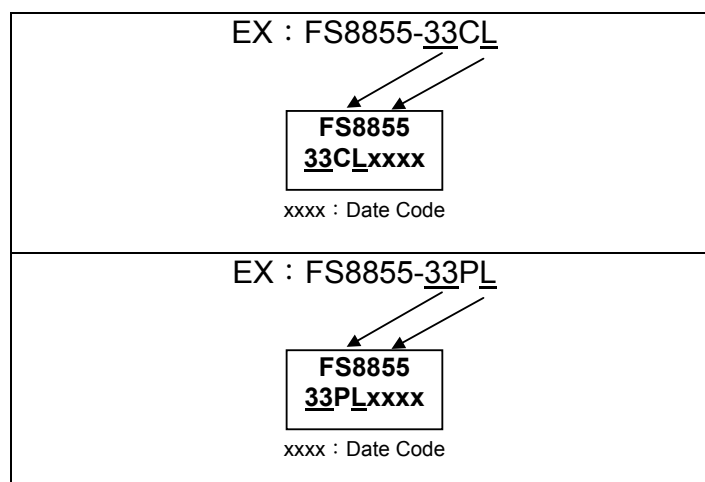

Pin Description

Part NO.	Symbol	Description
FS8855-xxCD FS8855-xxCE FS8855-xxCF FS8855-xxCW FS8855-xxCG	GND	Ground pin.
FS8855-xxCH FS8855-xxCJ FS8855-xxCX FS8855-xxCK	IN	Regulator input pin.
FS8855-xxCL FS8855-xxCI FS8855-xxCY	OUT	Regulator output pin.

IN is the regulator input pin. Supply voltage can range from 2.5V to 9.0V. Bypass with a 1 μ F capacitor to GND.

OUT is the output voltage pin. Sources up to 500mA. Bypass with a 3.3 μ F capacitor to GND.

GND provides the reference for all voltages.

Functional Block Diagram

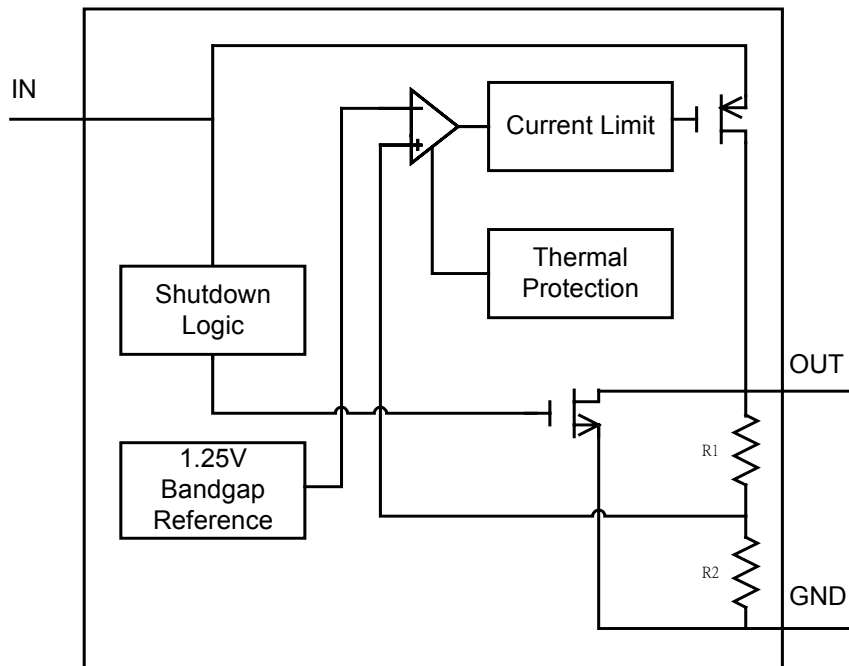

Typical Application Circuit

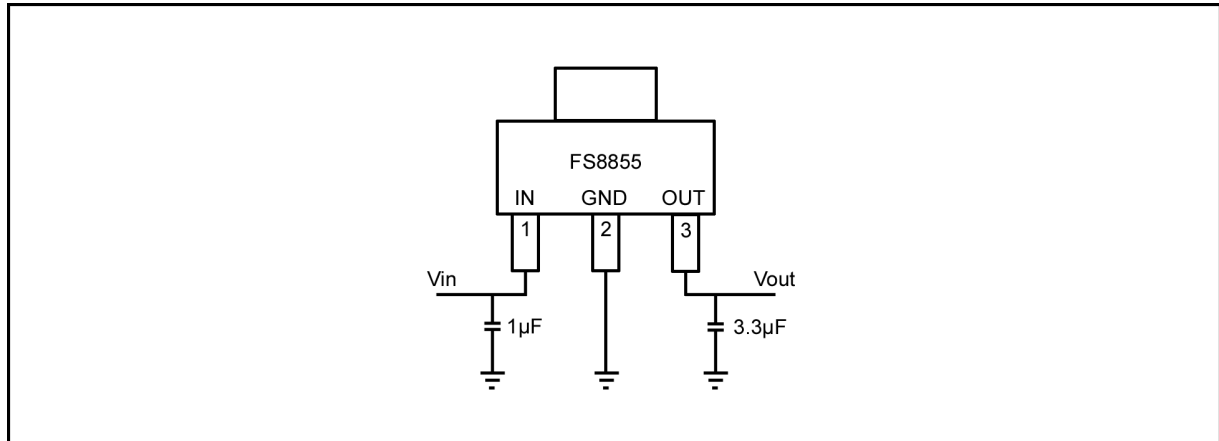

Absolute Maximum Ratings

Input voltage V_{IN} to GND	-----	10V
Output current limit, I_{LIMIT}	-----	0.8A
Continuous power dissipation, P_D ($\Delta T = T_J - T_A = 100^\circ\text{C}$)		
SOT-223	-----	0.65W
SOT-89	-----	0.55W
TO-92	-----	0.55W
* The power dissipation values are based on the condition that junction temperature T_J and ambient temperature T_A difference is 100°C .		
Junction Temperature, T_J	-----	$+155^\circ\text{C}$
Storage temperature range, T_{STG}	-----	-55°C to $+150^\circ\text{C}$
Operating junction temperature range	-----	-40°C to $+125^\circ\text{C}$
Lead temperature (soldering, 10sec)	-----	260°C

* Stresses beyond those listed under "absolute maximum ratings" may cause permanent damage to the device. These are stress ratings only, and function operation of the device at these or any other conditions beyond those indicated under "recommended operating conditions" is not implied. Exposure to absolute-maximum-rated conditions for extended periods may affect device reliability.

Electrical Characteristics

(TA=25°C, unless otherwise noted.)

Symbol	Parameter	Test Conditions	Min	Typ	Max	Unit
V _{IN}	Input Voltage		2.5		9.0	V
V _{OUT}	Output Voltage	V _{IN} =V _{OUT} +0.8V, I _{OUT} =1mA, V _{IN} ≤7V	V _{OUT} -0.035	V _{OUT}	V _{OUT} +0.035	V
		V _{IN} =V _{OUT} +0.8V, I _{OUT} =1mA, 7V < V _{IN} ≤ 9V	V _{OUT} -0.042	V _{OUT}	V _{OUT} +0.042	V
ΔV _{OUT}	Output Voltage Accuracy	V _{IN} >V _{OUT} +0.8V, V _{IN} ≤7V	-35		+35	mV
		V _{IN} >V _{OUT} +0.8V, 7V < V _{IN} ≤ 9V	-42		+42	mV
I _{MAX}	Maximum Load Current			500		mA
I _{LIMIT}	Current Limit				0.8	A
I _{SC}	Short-Circuit Current	V _{OUT} =0V, V _{IN} >V _{OUT} +0.8V		350	400	mA
I _Q	Ground Pin Current	I _{LOAD} =0mA to 500mA, V _{IN} =V _{OUT} +0.8V		65	120	μA
V _{DROP}	Dropout Voltage	I _{OUT} =1mA		1	1.2	mV
		I _{OUT} =100mA		100	120	mV
		I _{OUT} =500mA		650	800	mV
ΔV _{LINE}	Line Regulation	V _{OUT} +0.8V<V _{IN} <9V, I _{LOAD} =1mA		0.2	0.3	%/V
ΔV _{LOAD}	Load Regulation	I _{OUT} =0mA to 500mA		0.01	0.02	%/mA
e _N	Output Noise	F=1Hz to 10KHz, C _{OUT} =3.3μF		75		μVRMS
PSRR	Ripple Rejection	F=10KHz, C _{OUT} =3.3μF		75		dB
T _{SD}	Thermal Shutdown Temperature			155		°C
T _{HYS}	Thermal Shutdown Hysteresis			20		°C
θ _{JA}	Thermal Resistance	SOT-223			155	°C/W
		SOT-89			180	°C/W
		TO-92			180	°C/W

Typical Operating Characteristics

(C_{IN}=1.0μF, C_{OUT}=3.3μF, T_A=+25°C, unless otherwise noted.)

OUTPUT VOLTAGE vs. INPUT VOLTAGE

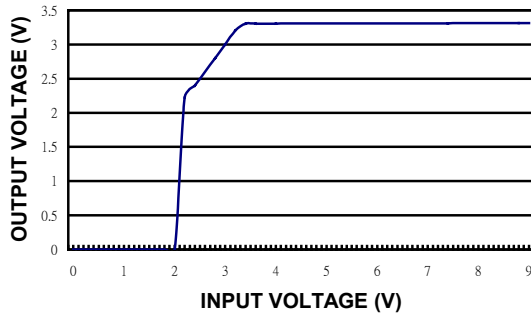

*EX : Model FS8855-33Cx

GROUND PIN CURRENT vs. AMBIENT TEMPERATURE

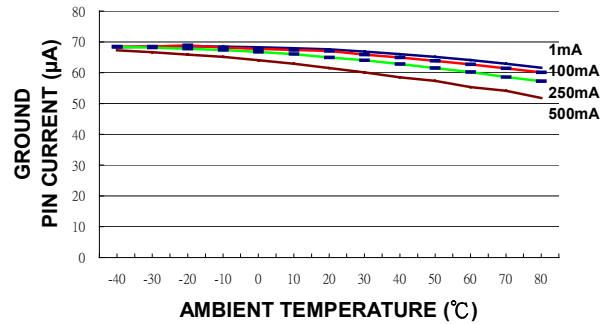

DROPOUT VOLTAGE vs. LOAD CURRENT

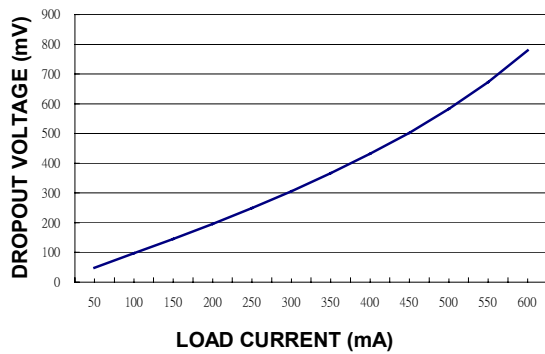

R_{on} vs. LOAD CURRENT

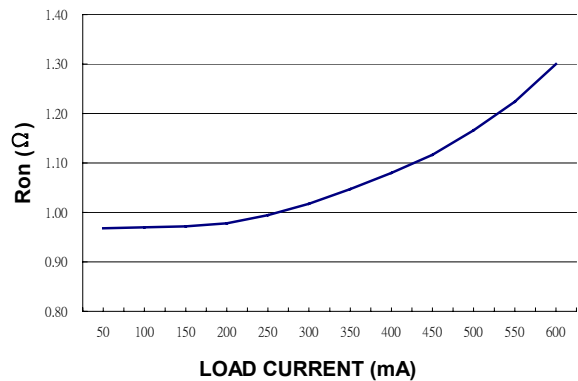

POWER SUPPLY REJECTION RATIO vs. FREQUENCY

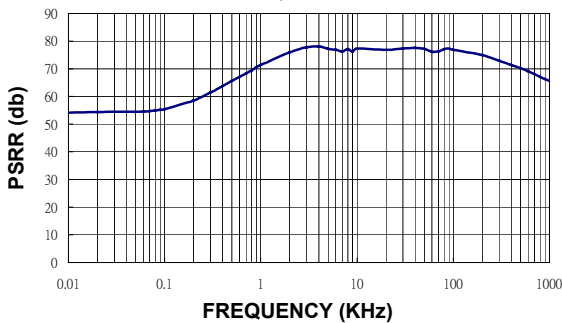

GND PIN CURRENT vs. LOAD CURRENT

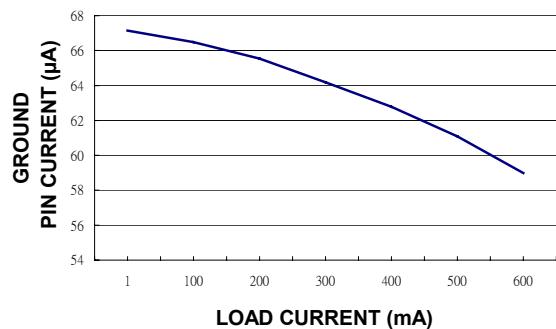

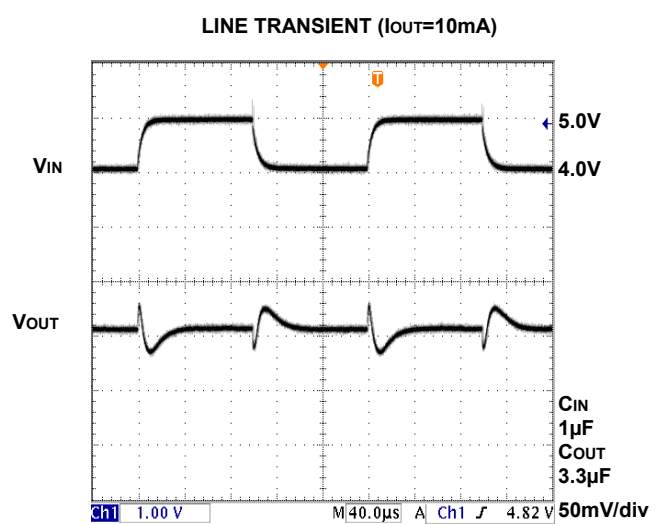
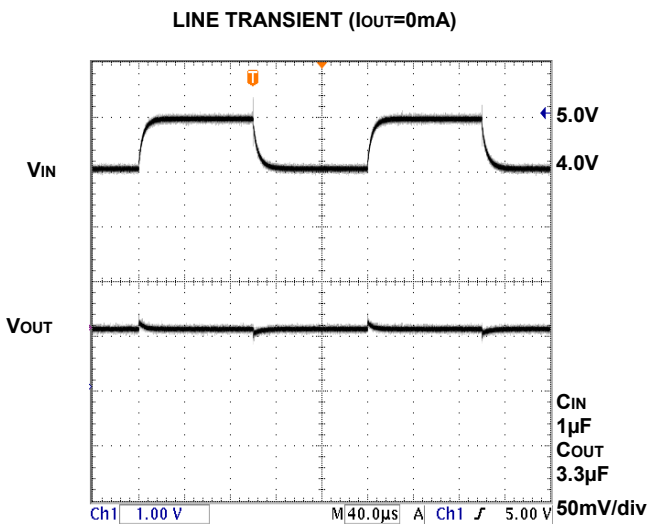
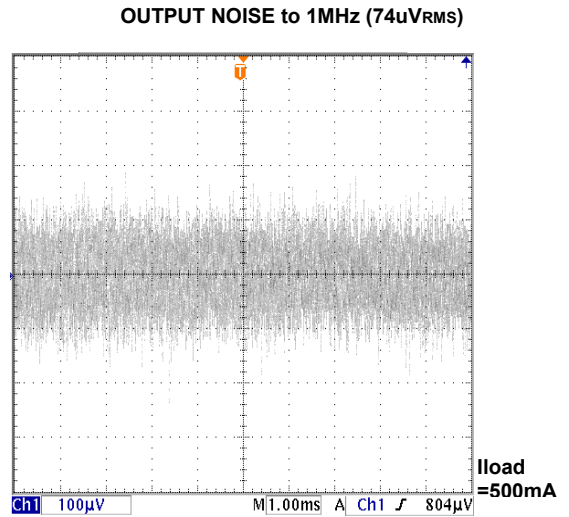
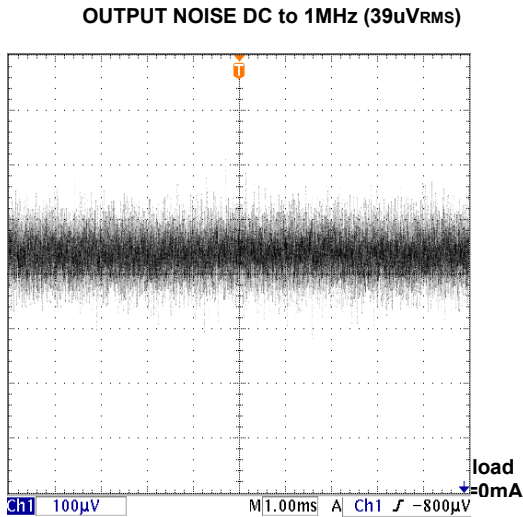
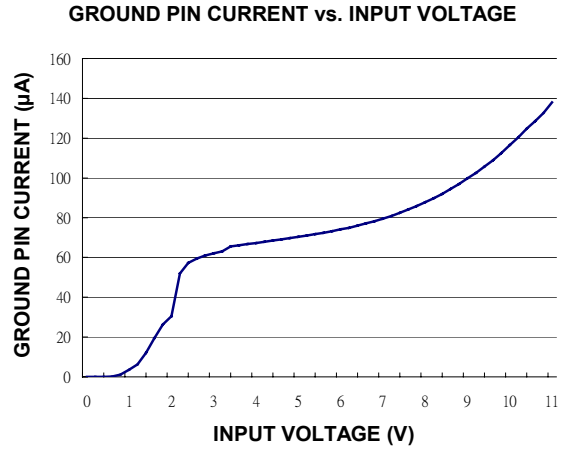
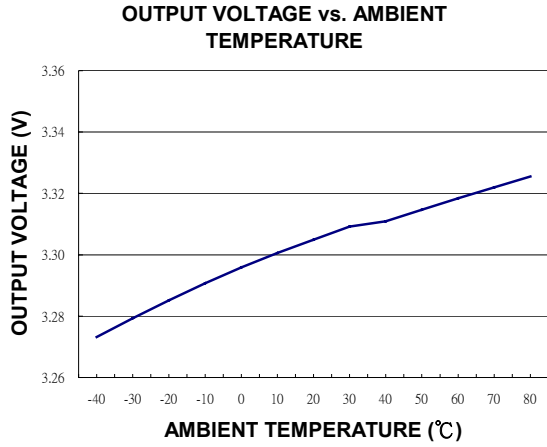

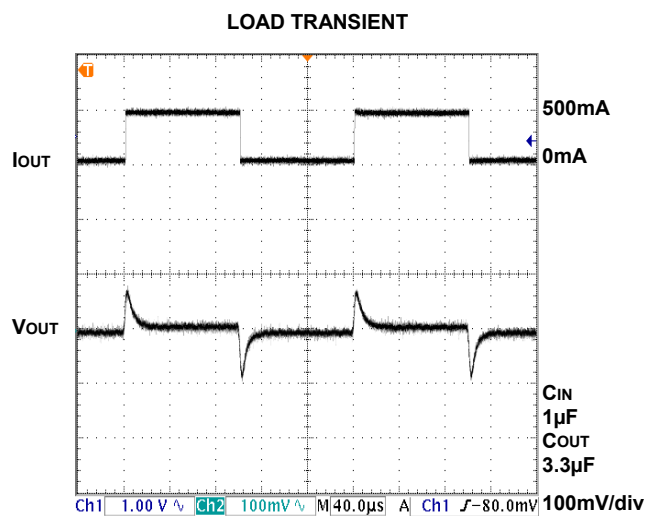
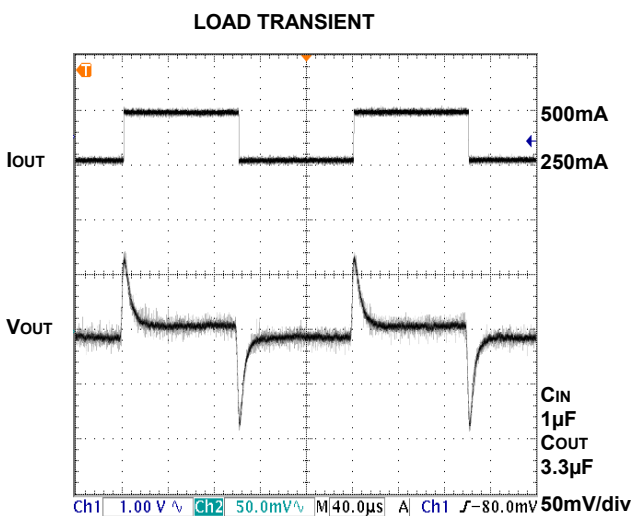
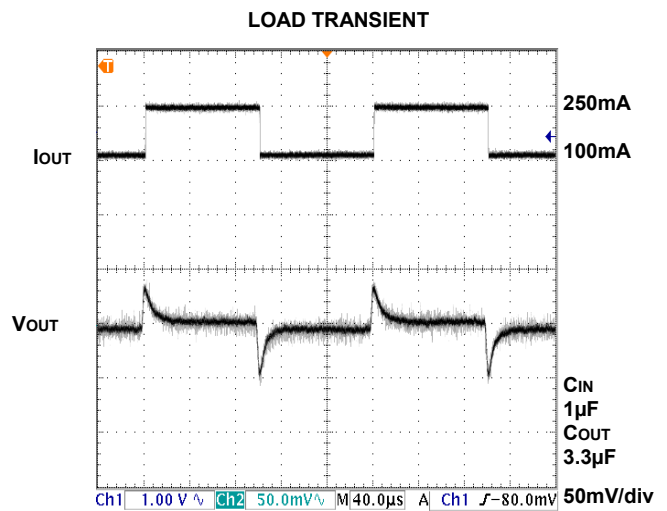
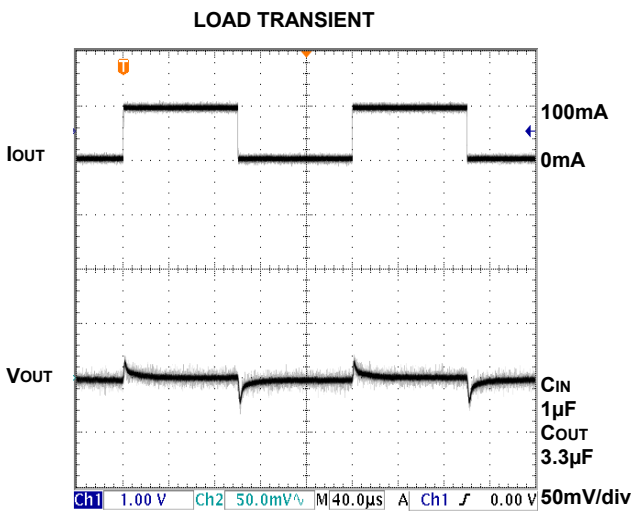
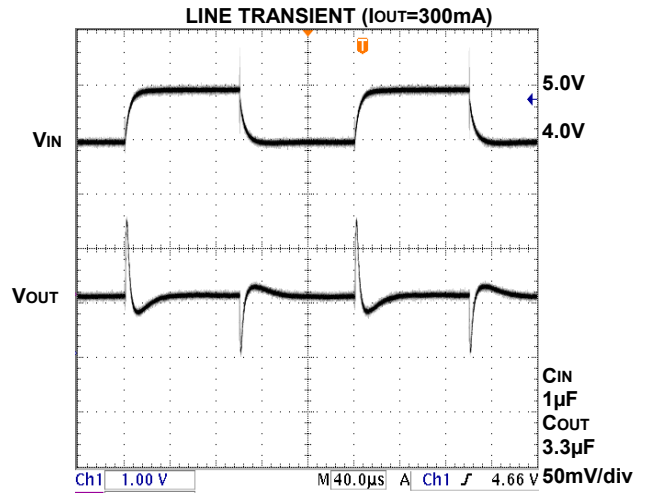
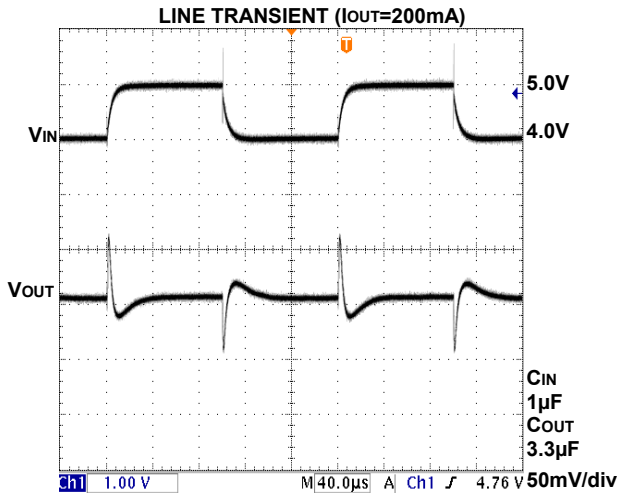

Detail Description

The FS8855 is a low-dropout linear regulator. The device provides preset 2.5V and 3.3V output voltages for output current up to 500mA. Other mask options for special output voltages from 1.3V to 4.5V with 100mV increment are also available. As illustrated in function block diagram, it consists of a 1.25V reference, error amplifier, P-channel pass transistor and an internal feedback voltage divider.

The 1.25V bandgap reference is connected to the error amplifier, which compares this reference with the feedback voltage and amplifies the voltage difference. If the feedback voltage is lower than the reference voltage, the pass-transistor gate is pulled lower, which allows more current to pass to the output pin and increases the output voltage. If the feedback voltage is too high, the pass-transistor gate is pulled up to decrease the output voltage.

The output voltage is feedback through an internal resistive divider connected to OUT pin. Additional blocks include an output current limiter, thermal sensor, and shutdown logic.

Internal P-channel Pass Transistor

The FS8855 features a P-channel MOSFET pass transistor. Unlike similar designs using PNP pass transistors, P-channel MOSFETs require no base drive, which reduces ground pin current. PNP-based regulators also waste considerable current in dropout when the pass transistor saturates, and use high base-drive currents under large loads. The FS8855 does not suffer from these problems and consumes only 65µA (Typ.) of ground pin current under heavy loads as well as in dropout conditions.

Output Voltage Selection

The FS8855 output voltage is preset at an internally trimmed voltage 2.5V, 3.3V or can be mask-optional from 1.3V to 4.5V with 100mV increment. The first two digits of part number suffix identify the output voltage (see [Ordering Information](#)). For example, the FS8855-33CL has a preset 3.3V output voltage.

Current Limit

The FS8855 also includes a fold back current limiter. It monitors and controls the pass transistor's gate voltage, estimates the output current, and limits the output current within 0.8A.

Thermal Overload Protection

Thermal overload protection limits total power dissipation in the FS8855. When the junction temperature exceeds $T_J = +155^{\circ}\text{C}$, a thermal sensor turns off the pass transistor, allowing the IC to cool down. The thermal sensor turns the pass transistor on again after the junction temperature cools down by 20°C , resulting in a pulsed output during continuous thermal overload conditions.

Thermal overload protection is designed to protect the FS8855 in the event of fault conditions. For continuous operation, the maximum operating junction temperature rating of $T_J = +125^{\circ}\text{C}$ should not be exceeded.

Operating Region and Power Dissipation

Maximum power dissipation of the FS8855 depends on the thermal resistance of the case and circuit board, the temperature difference between the die junction and ambient air, and the rate of airflow. The power dissipation across the devices is $P = I_{OUT} \times (V_{IN} - V_{OUT})$. The resulting maximum power dissipation is:

$$P_{MAX} = \frac{(T_J - T_A)}{\theta_{JC} + \theta_{CA}} = \frac{(T_J - T_A)}{\theta_{JA}}$$

Where $(T_J - T_A)$ is the temperature difference between the FS8855 die junction and the surrounding air, θ_{JC} is the thermal resistance of the package chosen, and θ_{CA} is the thermal resistance through the printed circuit board, copper traces and other materials to the surrounding air. For better heat-sinking, the copper area should be equally shared between the IN, OUT, and GND pins.

If the FS8855 uses a SOT-89 package and this package is mounted on a double sided printed circuit board with two square inches of copper allocated for "heat spreading", the resulting θ_{JA} is

180°C/W.

Based on a maximum operating junction temperature 125°C with an ambient temperature of 25°C, the maximum power dissipation will be:

$$P_{MAX} = \frac{(T_J - T_A)}{\theta_{JC} + \theta_{CA}} = \frac{(125 - 25)}{180} = 0.555W$$

Thermal characteristics were measured using a double sided board with 1" x 2" square inches of copper area connected to the GND pin for "heat spreading".

Input-Output Voltage

A regulator's minimum input-output voltage differential, or dropout voltage, determines the lowest usable supply voltage. In battery-powered systems, this will determine the useful end-of-life battery voltage. The FS8855 uses a P-channel MOSFET pass transistor, its dropout voltage is a function of drain-to-source on-resistance (R_{DS(ON)}) multiplied by the load current.

$$V_{DROPOUT} = V_{IN} - V_{OUT} = R_{DS(ON)} \times I_{OUT}$$

Package Outline

SOT-223

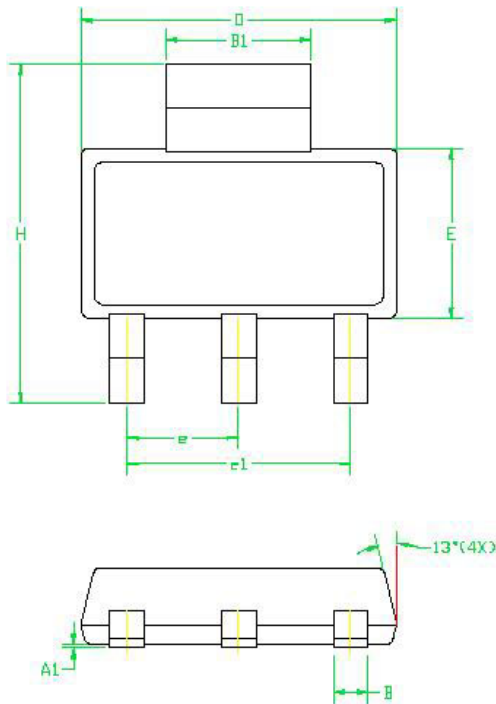

SYMBOLS	MILLIMETERS		INCHES	
	MIN	MAX	MIN	MAX
A	1.55	1.80	0.061	0.071
A1	0.02	0.12	0.0008	0.0047
B	0.60	0.80	0.024	0.031
B1	2.90	3.10	0.114	0.122
C	0.24	0.32	0.009	0.013
D	6.20	6.70	0.248	0.264
E	3.30	3.70	0.130	0.146
e	2.30 BSC		0.090 BSC	
e1	4.60 BSC		0.181 BSC	
H	6.70	7.30	0.264	0.287
L	0.90 MIN		0.036 MIN	
L2	0.06 BSC		0.0024 BSC	
α	0°	10°	0°	10°

SOT-89

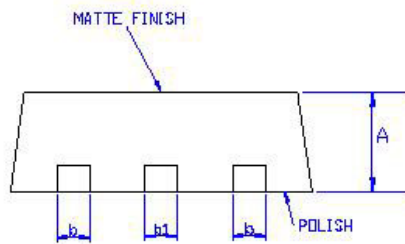
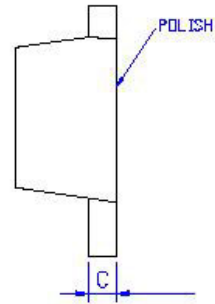
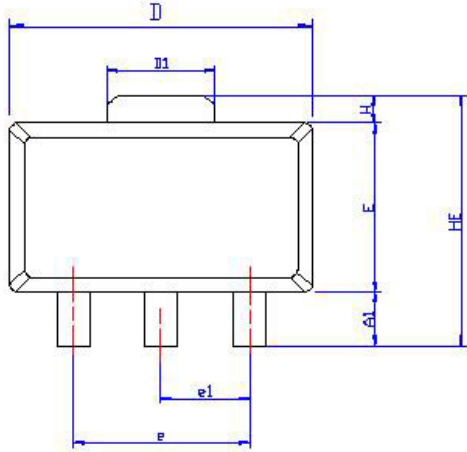

SYMBOLS	DIMENSIONS IN MILLIMETERS			DIMENSIONS IN INCHES		
	MIN	NOM	MAX	MIN	NOM	MAX
A	1.40	1.50	1.60	0.055	0.059	0.063
A1	0.80	1.04	—	0.031	0.041	—
b	0.36	0.42	0.48	0.014	0.016	0.018
b1	0.41	0.47	0.53	0.016	0.018	0.020
C	0.38	0.40	0.43	0.014	0.015	0.017
D	4.40	4.50	4.60	0.173	0.177	0.181
D1	1.40	1.60	1.75	0.055	0.062	0.069
HE	—	—	4.25	—	—	0.167
E	2.40	2.50	2.60	0.094	0.098	0.102
e	2.90	3.00	3.10	0.114	0.118	0.122
H	0.35	0.40	0.45	0.014	0.016	0.018
S	0.65	0.75	0.85	0.026	0.030	0.034
e1	1.40	1.50	1.60	0.054	0.059	0.063

TO-92

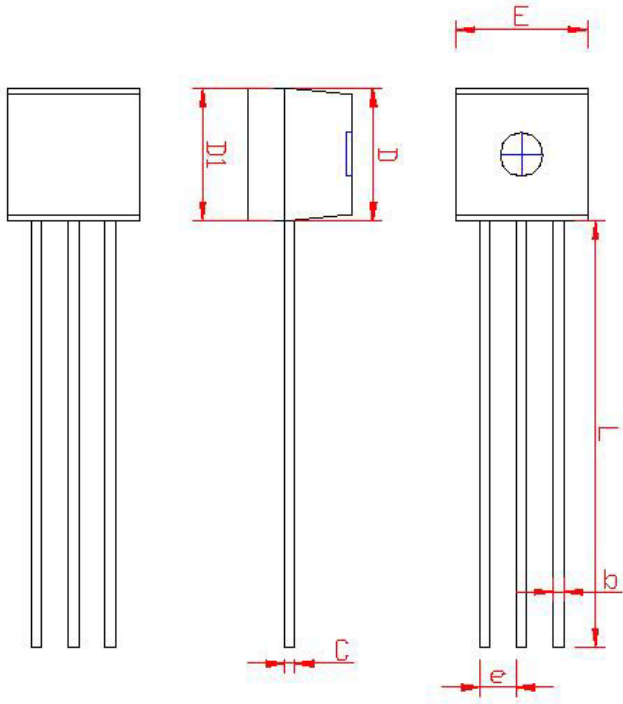

SYMBOL	MILLIMETERS		INCHES	
	MIN.	MAX.	MIN.	MAX.
	A	3.35	3.86	0.132
A1	1.0414	1.55	0.041	0.061
b	0.254	0.508	0.010	0.020
E	4.34	4.85	0.171	0.191
C	0.254	0.508	0.010	0.020
L	14.53	15.04	0.572	0.592
e	1.143	1.397	0.045	0.055
G	3.683	4.191	0.145	0.165
D	4.29	4.80	0.169	0.189
D1	4.34	4.85	0.171	0.191

